

COLUMBIA LIBRARIES OFFSITE

HEALTH SCIENCES STANDARD



HX00038792

RG 101

A15

Columbia University  
in the City of New York

College of Physicians and Surgeons



Library





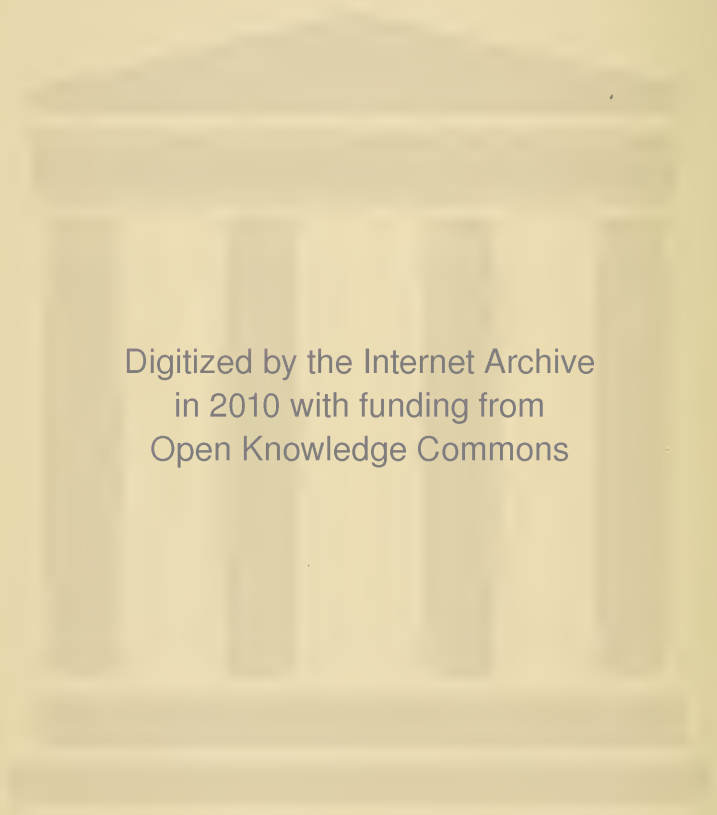

Digitized by the Internet Archive  
in 2010 with funding from  
Open Knowledge Commons

A SYSTEM OF GYNÆCOLOGY

•The  Co. •



A

# SYSTEM OF GYNÆCOLOGY

BY MANY WRITERS

EDITED BY

THOMAS CLIFFORD ALLBUTT

M.A., M.D., LL.D., F.R.C.P., F.R.S., F.L.S., F.S.A.

REGIUS PROFESSOR OF PHYSIC IN THE UNIVERSITY OF CAMBRIDGE,  
FELLOW OF GONVILLE AND CAIUS COLLEGE

AND

W. S. PLAYFAIR

M.D., LL.D., F.R.C.P.

PROFESSOR OF OBSTETRIC MEDICINE IN KING'S COLLEGE, AND  
OBSTETRIC PHYSICIAN TO KING'S COLLEGE HOSPITAL

New York

THE MACMILLAN COMPANY

LONDON: MACMILLAN & CO., LTD.

1897

*All rights reserved*

RG101  
A25

COPYRIGHT, 1896,

By THE MACMILLAN COMPANY.

---

Set up and electrotyped October, 1896. Reprinted October,  
1897.

Norwood Press  
J. S. Cushing & Co. — Berwick & Smith  
Norwood Mass. U.S.A.

## PREFACE

IN the earlier treatises on medicine diseases of women were included, but were of necessity imperfectly described.

Of late years this department of medicine has grown so largely that the Editor of the new *System of Medicine* found it would be better to deal with it, as a whole, in a volume especially devoted to the subject; in the preparation of this volume I have assisted him as Joint Editor.

The advances made within the last few years in Gynæcology are perhaps more remarkable than in any other branch of medicine.

The whole subject is one of recent development. Even the work of its pioneers is within the recollection of the older amongst us: a treatise on gynæcology written twenty years ago is absolutely useless as a guide to the practice of to-day, and does not contain even a reference to many of the topics now known to be of primary importance in connection with diseases of the reproductive organs in women; on the other hand, many opinions and methods of treatment, then largely taught and practised, have justly passed into oblivion.

Much of this great progress is undoubtedly on the surgical aspect of the subject. The increasing frequency of abdominal sections has directed attention to the diseased states thus revealed, and to methods of treating them, previously quite unknown.

Unbalanced zeal has had its inevitable result of injudicious practice, which is to be regretted; against adventure of this kind protests have been made by the more conservative minded

members of our profession, often justly, sometimes unjustly. Nor is it in this country alone that this adventurousness is seen. Any one familiar with current gynæcological practice, both on the Continent and in the United States, must know that the same spirit is active there. Indeed, it is probable that gynæcologists abroad are apt to impute to their British colleagues a backwardness in adopting methods of treatment largely practised by themselves; many of us think, too largely. Conservatism of this sort may have its faults, but, on the whole, it is not to be regretted, and it is surely better than to err in the opposite direction.

It is obvious that a collection of independent essays, written by men on topics which they have specially studied, must carry more weight, and be more useful than any work compiled by a single writer. An endeavour has been made to entrust the several subjects to thoroughly representative men; and it is hoped that the results of their combined labours will give an accurate exposition of gynæcology as it is taught and practised amongst us.

I am myself alone responsible for the selection of the contributors, which my co-editor has left to my judgment; but I am not in any way responsible for the opinions they have expressed,—some of them, indeed, I do not share.

In a work by various authors differences of opinion will necessarily be found; some condemn methods of practice which others approve and recommend. This does not appear to be objectionable; it is surely better that in vexed and disputed questions both sides should be fairly considered.

W. S. PLAYFAIR.



## CONTENTS

	PAGE
THE DEVELOPMENT OF MODERN GYNÆCOLOGY. M. Handfield-Jones . . . . .	1
THE ANATOMY OF THE FEMALE PELVIC ORGANS. D. Berry Hart . . . . .	31
MALFORMATIONS OF THE GENITAL ORGANS IN WOMAN. J. William Ballantyne . . . . .	63
THE ETIOLOGY OF THE DISEASES OF THE FEMALE GENITAL ORGANS. W. Balls-Headley . . . . .	112
DIAGNOSIS IN GYNÆCOLOGY. Robert Boxall . . . . .	151
INFLAMMATION OF THE UTERUS. A. H. Freeland Barbour . . . . .	187
THE NERVOUS SYSTEM IN RELATION TO GYNÆCOLOGY. W. S. Playfair . . . . .	220
STERILITY. Henry Gervis . . . . .	231
GYNÆCOLOGICAL THERAPEUTICS. Amand Routh . . . . .	249
THE ELECTRICAL TREATMENT OF DISEASES OF WOMEN. Robert Milne Murray . . . . .	300
DISORDERS OF MENSTRUATION. John Halliday Croom . . . . .	339
DISEASES OF THE EXTERNAL GENITAL ORGANS. William J. Smyly . . . . .	372
DISPLACEMENTS OF THE UTERUS. Alexander Russell Simpson . . . . .	393
MORBID CONDITIONS OF THE FEMALE GENITAL ORGANS RESULTING FROM PARTURITION. George Ernest Herman . . . . .	425
EXTRA-UTERINE GESTATION. John Bland Sutton . . . . .	451
PELVIC INFLAMMATION. Charles James Cullingworth . . . . .	485
PELVIC HÆMATOCELE. William Overend Priestley . . . . .	524
BENIGN GROWTHS OF THE UTERUS. F. W. N. Haultain . . . . .	561
HYSTERECTOMY. J. Knowsley Thornton . . . . .	611

	PAGE
MALIGNANT DISEASES OF THE UTERUS. W. J. Sinclair . . . . .	643
PLASTIC GYNÆCOLOGICAL OPERATIONS. John Phillips . . . . .	743
DISEASES OF THE FALLOPIAN TUBES. Alban Doran . . . . .	782
DISEASES OF THE OVARY. W. S. A. Griffith . . . . .	836
OVARIOTOMY. J. Greig Smith . . . . .	872
CHRONIC INVERSION OF THE UTERUS. Edward Malins . . . . .	911
DISEASES OF THE FEMALE BLADDER AND URETHRA. Henry Morris . . . . .	927
INDICES . . . . .	959

## ILLUSTRATIONS

FIG.	PAGE
1. Brim of Bony Pelvis . . . . .	32
2. Diagram of Bony Pelvis and of Pelvic Floor . . . . .	32
3. Sagittal Mesial Section of Female Pelvic Floor . . . . .	33
4. Virgin External Genitals with the Labia Majora separated . . . . .	34
5. Rectal and Vaginal Mucous Membrane . . . . .	36
6. Sphincter Ani in full-time Fœtus . . . . .	38
7. Axial Transverse Section of right half of Female Pelvic Floor . . . . .	39
8. Axial Transverse Section of Female Pelvic Floor . . . . .	40
9. Axial Coronal Section of right half of Female Pelvis . . . . .	41
10. Blood-supply of Uterus . . . . .	42
11. Lymphatics of Uterus . . . . .	42
12. Lymphatics of Uterus and Pelvis . . . . .	43
13. Nerve Diagram . . . . .	44
14. Relations of Uterus and Ovaries viewed through Brim . . . . .	45
15. Sagittal Lateral Section of Female Pelvis . . . . .	46
16. Uterine Mucous Membrane showing relation of Glands and Stroma . . . . .	47
17. Cervix and upper part of Vagina showing Rugæ . . . . .	47
18. Seal's Ovary showing Cortical and Medullary Layers . . . . .	49
19. Sagittal Lateral Section of Genital Organs in 3½ months' Fœtus . . . . .	50
20. Pelvis and Contents from above . . . . .	52
21. Perineal Region . . . . .	54
22. Sacral Section of Pelvic Floor . . . . .	55
23. Diagram of Genu-Pectoral Posture showing Vaginal Distension . . . . .	56
24. Dissection from behind . . . . .	58
25. T. S. of Wolffian Bodies in six weeks' Fœtus . . . . .	59
26. T. S. Pelvis, six weeks' Fœtus . . . . .	59

FIG.	PAGE
27. T. S. of six weeks' Fœtus showing Genital Cord . . . . .	60
28. Section of Ovary and Wolffian Body, Human Embryo, third month . . . . .	60
29. L. S. of 3½ months' Fœtus to show development of Hymen . . . . .	61
30. Diagram of developing and fully formed Genital Tract . . . . .	62
31. Anterior View of right Uterine Appendages . . . . .	70
32. Congenital absence of outer two-thirds of right Fallopian Tube . . . . .	71
33. Uterus Didelphys . . . . .	75
34. Uterus Bicornis . . . . .	76
35. Uterus Septus . . . . .	78
36. Uterus Unicornis, posterior view . . . . .	79
37. Atresia Vulvæ Superficialis . . . . .	92
38. Anus Vulvalis . . . . .	94
39. Pseudo-Hermaphroditism, Perineo-Scrotal Hypospadias . . . . .	104
40. Female Generative Organs of Halmaturus . . . . .	114
41. Two completely separated Uteri of many Rodentia . . . . .	114
42. Single Uterus continued into two separate Cornua of the Insectivora, Carnivora, Cetacea, and Ungulata . . . . .	114
43. The single Uterus of the Simiæ and Man . . . . .	114
44. Section of a Catarrhal Patch on the Vaginal Aspect of the Cervix . . . . .	196
45. Healing of a Catarrhal Patch treated by Astringent or Antiseptic Injections . . . . .	201
46, 47. Schroeder's operation for excision of the Cervical Mucous Membrane in Cervical Catarrh . . . . .	202
48, 49. Section of Tissue removed by Curette from a case of Interstitial Endometritis . . . . .	208
50. Section of the Glands from a case of Glandular Endometritis . . . . .	208
51. Section of the Uterine Tissue in a case of Chronic Metritis . . . . .	214
52. Leiter's Coils . . . . .	257
53. Application of Leiter's Coils . . . . .	258
54. Bath Speculum . . . . .	258
55. Syphon Douche . . . . .	259
56. Bed Bath . . . . .	260
57. Ointment Carrier (Matthews Duncan's) . . . . .	263
58. Diverging Speculum (Neugebauer's) . . . . .	263
59. Playfair's Probe . . . . .	264
60. Uterine Tenaculum Forceps (Sims') . . . . .	264
61. Intra-Uterine Canula (Athill's); Platinum Canula, with Stilette . . . . .	265
62. Uterine Scarifier . . . . .	266



FIG.	PAGE
63. Steriliser for Instruments (Harrison Cripps') . . . . .	268
64. Glass Jar for Sponges, Wool-Pads, etc. . . . .	269
65. Steriliser for Ligatures . . . . .	269
66. Catgut or Silk sterilised in Alcohol . . . . .	269
67. Junker's Inhaler . . . . .	273
68. Griffin's Speculum . . . . .	275
69. Cusco's Speculum . . . . .	275
70. Gauge Applicator (Whalebone) . . . . .	275
71. Forceps to introduce Gauge . . . . .	275
72. Cervical Speculum (Bantock's) . . . . .	276
73. Duckbill Speculum (Sims') . . . . .	277
74. Barnes' Tent Introducer . . . . .	277
75. Chambers' Tent Introducing Forceps . . . . .	278
76. Uterine Dilator (Hegar's improved) . . . . .	282
77. Uterine Dilators (Hayes') . . . . .	282
78. Uterine Dilator (Matthews Duncan's) . . . . .	282
79. Clover's Crutch . . . . .	233
80. Teale's Forceps . . . . .	284
81. Budin's Tube . . . . .	285
82. Graily Hewitt's Uterine Tube . . . . .	286
83. Goodell's two Parallel-bladed Dilator . . . . .	287
84. Uterine Dilator (Ellinger's) . . . . .	288
85. Sims' Three-bladed Dilator . . . . .	288
86. Palmer's Two-bladed Dilator . . . . .	289
87. Dilator (Priestley's) . . . . .	289
88. Uterine Dilators (Reid's) . . . . .	289
89. Scissors, Uterine (Kuchenmeister's) . . . . .	291
90. Sims' Metrotome . . . . .	292
91. Simon's Uterine Scoop . . . . .	293
92. Sims' Pliable Curette . . . . .	293
93. Double Uterine Curette (Gervis') . . . . .	294
94. Recamier's Curette . . . . .	294
95. Uterine Scoop, or Spoon Saw (Thomas') . . . . .	295
96. Dredging Curette (Bell's) . . . . .	295
97. Uterine Flushing Curette (Auvard's) . . . . .	295
98. Routh's Flushing Curette . . . . .	295
99. Vertical Section three months after Curetting . . . . .	297

FIG.	PAGE
100. Vertical Section of the Uterine Mucous Membrane fifty-five days after the application of a Caustic . . . . .	298
101. Léclanche Cell . . . . .	301
102. Carbon Rheostat . . . . .	303
103. Edelmann Galvanometer . . . . .	304
104. Weston Milliampère Meter . . . . .	305
105. Intra-Uterine Electrode . . . . .	305
106. Apostoli's Carbon Electrode . . . . .	306
107. Adjustable Platinum Electrode . . . . .	306
108. Electrode for Puncture . . . . .	306
109. Vaginal Electrodes . . . . .	307
110. Portable Battery with Collector and Galvanometer . . . . .	309
111. Spamer's Induction Coil . . . . .	310
112. Sledge Induction Coil . . . . .	310
113. Regulator Switch Board for Continuous and Induced Currents . . . . .	311
114. Switch Board for regulating Lighting Currents by means of Re- sistances . . . . .	312
115. Diagram of Switch Board for regulating Lighting Currents by means of Shunt . . . . .	313
116. Switch Board for Shunt Regulation . . . . .	313
117. Descent of Perineal Hernia in front of the Broad Ligament . . . . .	380
118. Reposition of the Retroverted Uterus with the Sound . . . . .	418
119. Hodge Pessary in the Vagina retaining the Uterus <i>in situ</i> . . . . .	419
120. Profile on Section of lacerated, but healthy, Cervix Uteri . . . . .	427
121. Profile on Section of lacerated and inflamed Cervix Uteri . . . . .	427
122. Lacerations of Cervix Uteri and Vagina . . . . .	428
123. Laceration of Vagina forming a "Pocket" . . . . .	430
124. Central Rupture of Perineum . . . . .	434
125. Diagram showing different kinds of Fistula . . . . .	437
126. Annular sloughing of Cervix Uteri, upper surface . . . . .	438
127. Annular sloughing of Cervix Uteri, lower surface . . . . .	439
128. Slough in one mass of Cervix Uteri, upper part of Vagina, and base of Bladder . . . . .	440
129. Dilated Abdominal Ostium . . . . .	454
130. Gravid Tube . . . . .	455
131. Tubal Mole in Section . . . . .	456
132. Microscopical Characters of Chorionic Villi in section, in Blood-clot . . . . .	457

FIG.	PAGE
133. Diagram to show the early relations of the Amnion and Chorion and the Subchorionic Chamber . . . . .	458
134. An early Tubal Embryo, showing the Polar Disposition of the Villi . . . . .	458
135. A Gravid Tube with patent Ostium . . . . .	460
136. Fallopian Tube and Ovary; Mole and Corpus Luteum from a case of complete Tubal Abortion . . . . .	461
137. Uterine Decidua; from a case of Tubal Pregnancy . . . . .	465
138. Transverse Section of the Pelvis of a Woman with an Embryo and Placenta of the fourth month of Gestation occupying the right Mesometrium . . . . .	466
139. Sagittal Section of a Cadaver, with a Mesometrium Pregnancy at Term . . . . .	467
140. Tubo-Uterine Gestation . . . . .	470
141. Injected Uterus with Fibroid . . . . .	566
142. Microscopic Section of soft Fibromyoma . . . . .	567
143. Microscopic Section of common Fibromyoma . . . . .	568
144. Section of Fibroid Uterus . . . . .	569
145. Diagram of Growth of Uterine Fibroids . . . . .	570
146. Encapsulated Submucous Fibroid becoming Polypoidal . . . . .	571
147. Submucous Polypus . . . . .	572
148. Uterus, showing Subperitoneal Fibroids . . . . .	575
149. Submucous Intravaginal Cervical Fibroid . . . . .	582
150. Subserous Cervical Fibroid, tilting Uterus above Pubes and bulging Posterior Vaginal Wall . . . . .	582
151. Advanced Fibrocystic Degeneration of Stalked Subperitoneal Fibroid, with partially Twisted Pedicle . . . . .	587
152. Œdematous Interstitial Cystic Fibromyoma . . . . .	588
153. Microphotograph of Œdematous Fibroid, showing Endothelial Lined Spaces . . . . .	589
154. Complete Rupture of the Perineum and the lower Portion of the Recto-Vaginal Septum . . . . .	746
155. Relations of Levator Ani to the Rectum and Vaginal Walls; normal Condition . . . . .	746
156. Relations of Levator Ani to the Rectum and Vaginal Walls; injured Condition . . . . .	747
157. Perineorrhaphy; preliminary Incisions . . . . .	749
158. Perineorrhaphy; Denudation . . . . .	749
159. Purse-string Suture . . . . .	750

FIG.	PAGE
160. Perineorrhaphy ; Repair of the Recto-Vaginal Septum . . . . .	750
161. Section of torn Sphincter . . . . .	750
162. Perineorrhaphy ; Recto-Vaginal Septum repaired . . . . .	751
163.        ,,        (Simon-Hegar Method of Suture) . . . . .	752
164.        ,,        ,,        ,,        ,,        2nd Stage and Side View	753
165.        ,,        Alexander Duke's Method . . . . .	754
166. Surface View of Posterior Vaginal Wall with Right and Left Lateral Sulci	755
167.        ,,        ,,        ,,        ,,        ,,        with both Lateral Vaginal Sulci sutured . . . . .	755
168. Elytrorrhaphy (Sims') . . . . .	757
169. Anterior Colporrhaphy ; Denudation and first Layer of continuous Suture completed . . . . .	758
170. Anterior Colporrhaphy ; Passage of second continuous superimposed Suture . . . . .	759
171. Anterior Colporrhaphy ; Passage of third Layer of superimposed Suture .	759
172. Lefort's Operation . . . . .	760
173. Colpoperineorrhaphy, first stage . . . . .	760
174.        ,,        ,,        second stage . . . . .	761
175.        ,,        ,,        third stage . . . . .	761
176. Stoltz's Operation for Cystocele . . . . .	762
177. Urethrocele . . . . .	762
178. Vaginal Fixation . . . . .	764
179. Emmet's Scissors (left angular) . . . . .	766
180.        ,,        ,,        (angular and curved) . . . . .	767
181. Operation for Subinvolution . . . . .	767
182. Amputation of Cervix ; Hegar Method . . . . .	770
183.        ,,        ,,        Marekwald Method . . . . .	770
184. Vesico-Vaginal Fistula Knives (Sims') . . . . .	774
185. Uterine Hook (Emmet's) for making counter pressure . . . . .	774
186. Wire Adjuster . . . . .	774
187. Mode of freshening the Edges of a Fistula by "Flap-splitting" . . . . .	775
188. Mode of passing Sutures in Vesico-Vaginal Fistula . . . . .	775
189. Mode of applying Counter Pressure to the Point of the Needle by means of a Blunt Hook (Emmet's) . . . . .	776
190. Method of fixing and twisting the Sutures (Sims') . . . . .	777
191. Juxta-Cervical Fistula (superficial variety) . . . . .	779
192. Kolpogleisis . . . . .	781



FIG.	PAGE
193. Section of a healthy Tube from a young Subject . . . . .	784
194. One of the Plicæ in Fig. 193 as seen under a $\frac{1}{3}$ inch objective . . . . .	785
195. Section, near the Ostium, of an inflamed Tube . . . . .	786
196. Section of a Plica, showing the earlier Changes seen in Salpingitis . . . . .	787
197. Section showing the free Surface of the Interior of a Tube which had been obstructed and dilated for a long period . . . . .	787
198. Section of an inflamed Tube, in its Middle Third, showing active Inflam- mation . . . . .	788
199. The free Surface of the Interior of a suppurating Tube . . . . .	789
200. Section of a suppurating Tube, showing advanced Disease . . . . .	790
201. Ovary and Tube, showing Obstruction of the Ostium by a Perimetritic Band which forms a Deep Pouch . . . . .	792
202. Tube showing Obstruction of the Ostium from inflammatory Swelling of its Coats . . . . .	792
203. Tubes and Uterus from a Patient who died of Phthisis three years after Incision of Peritoneum infected with Tubercle . . . . .	797
204. Cystic Fibromyoma of the Fimbriæ . . . . .	802
205. Microscopical Section of a Papillomatous Outgrowth from the Left Tube . . . . .	804
206. Papilloma of the Fallopian Tube . . . . .	808
207. " " " Sections of an outgrowth under high and low Power . . . . .	809
208. Primary Cancer of Fallopian Tube . . . . .	814
209. " " " " in Section, with Tubule-like Structure . . . . .	815
210. Dr. Cullingworth's case of Primary Cancer of the Tube . . . . .	819
211. Dr. Essex Wynter's case of Cancer of the Tube . . . . .	822
212. Diagram to show placing of Table, Surgeon, Assistants, Nurse, and In- struments in Ovariotomy . . . . .	876
213. Tait's Modification of Wells' Catch-Forceps . . . . .	877
214. Catch-Forceps (J. Greig Smith's Model) . . . . .	878
215. Blades of J. Greig Smith's Forceps . . . . .	878
216. J. Greig Smith's Peritoneal Catch-Forceps . . . . .	878
217. " " Large Pressure-Forceps . . . . .	879
218. Wells' Large Forceps, bent . . . . .	879
219. " " " straight . . . . .	879
220. " " Pressure-Forceps, Rectangular Blades . . . . .	880
221. Thornton's T-shaped Pressure-Forceps . . . . .	880
222. Wells' Clamp-Forceps . . . . .	881

FIG.	PAGE
223. Nélaton's Cyst-Forceps . . . . .	881
224. Sydney Jones' Cyst-Forceps . . . . .	881
225. J. Greig Smith's Scissors . . . . .	882
226. „ „ Reel Holder . . . . .	882
227. Wells' Large Cyst-Trocar . . . . .	883
228. Wells' Small Cyst-Trocar with Fitch's Dome . . . . .	883
229. Tait's Cyst-Trocar . . . . .	883
230. Sydney Jones' Pedicle Needle . . . . .	884
231. Wells' Pedicle Needle . . . . .	884
232. J. Greig Smith's Forceps for placing Ligature on Pedicle . . . . .	884
233. Keith's Glass Drainage Tube . . . . .	884
234. Glass Drainage Tube . . . . .	885
235. Sponge Holder . . . . .	885
236. J. Greig Smith's Suture Instrument . . . . .	885
237. Tait's Staffordshire Knot . . . . .	889
238. Triple interlocking Ligature, Threads inserted, Loops divided . . . . .	890
239. „ „ „ Threads interlocked ready for tying . . . . .	890
240. „ „ „ Threads tied . . . . .	890
241. Screw for aiding in the Delivery of Solid Tumours . . . . .	895
242. Aveling's Repositor for producing Elastic Pressure . . . . .	923

## LIST OF AUTHORS

- Ballantyne, John Wm., M.D., F.R.C.P., F.R.S. Edin., Lecturer on Midwifery and Diseases of Women, Medical College for Women, Edinburgh.
- Balls-Headley, W., M.A., M.D., F.R.C.P., Lecturer on Midwifery and Diseases of Women, University of Melbourne.
- Barbour, A. H. Freeland, M.A., B.Sc., M.D., F.R.C.P. Edin., Lecturer on Midwifery and Diseases of Women, Edinburgh Medical School.
- Boxall, Robert, M.D., M.R.C.P., Assistant-Obstetric Physician and Lecturer on Practical Midwifery and Gynæcology, Middlesex Hospital.
- Croom, John Halliday, M.D., F.R.C.P. Edin., Physician to the Royal Infirmary. Edinburgh, Clinical Lecturer on Diseases of Women, and Lecturer on Midwifery and Diseases of Women at the Medical School.
- Cullingworth, Chas. James, M.D., D.C.L., F.R.C.P., Obstetric Physician and Lecturer on Midwifery and Diseases of Women, St. Thomas' Hospital.
- Doran, Alban, F.R.C.S. Eng., Surgeon to the Samaritan Free Hospital for Women.
- Gervis, Henry, M.D., F.R.C.P., Consulting Obstetric Physician to St. Thomas' Hospital.
- Griffith, Walter, S.A., M.D., F.R.C.P., Assistant-Physician Accoucheur to St. Bartholomew's Hospital.
- Handfield-Jones, Montague, M.D., Obstetric Physician and Lecturer on Midwifery and Diseases of Women to St. Mary's Hospital.
- Hart, David Berry, M.D., F.R.C.P. Edin., Lecturer on Midwifery and Diseases of Women, Edinburgh Medical School.
- Haultain, F. W. N., M.D., F.R.C.P. Edin., Lecturer on Midwifery and Diseases of Women, Edinburgh Medical School.
- Herman, Geo. Ernest, M.B., F.R.C.P., Senior Obstetric Physician and Lecturer on Midwifery to the London Hospital.
- Malins, Edward, M.D., M.R.C.P., Obstetric Physician to the Birmingham General Hospital, Professor of Midwifery at Mason College.
- Morris, Henry, M.A., M.B., F.R.C.S., Surgeon to the Middlesex Hospital.

- Murray, Robt. Milne, M.A., M.B., F.R.C.P. Edin., F.R.S.E., Lecturer on Midwifery and Diseases of Women, Edinburgh Medical School.
- Phillips, John, M.A., M.D., F.R.C.P., Assistant Obstetric Physician to King's College Hospital.
- Playfair, W. S., M.D., LL.D., F.R.C.P., Professor of Obstetric Medicine in King's College, and Obstetric Physician to King's College Hospital.
- Priestley, Sir W. Overend, M.P., M.D., LL.D., F.R.C.P., Consulting Obstetric Physician to King's College Hospital.
- Routh, Amand J., M.D., B.S., M.R.C.P., Obstetric Physician to out-patients to Charing Cross Hospital, Physician to Samaritan Free Hospital for Women.
- Simpson, Alex. Russell, M.D., F.R.C.P. Edin., Professor of Midwifery, University of Edinburgh.
- Sinclair, W. Japp, M.A., M.D., M.R.C.P., Professor of Obstetrics and Gynæcology, Owens College, Victoria University.
- Smith, Jas. Greig, M.A., M.B., F.R.S. Edin., Professor of Surgery, University College, Bristol.
- Smyly, Wm. J., M.D., F.R.C.P. Ireland, Master of the Rotunda Hospital, Dublin.
- Sutton, John Bland, F.R.C.S., Assistant Surgeon to the Middlesex Hospital, Surgeon to the Chelsea Hospital for Women.
- Thornton, J. Knowsley, M.B., C.M., Consulting Surgeon to the Samaritan Free Hospital.



*In order to avoid frequent interruption of the text, the Editor has only inserted the numbers indicative of items in the lists of "References" in cases of emphasis, where two or more references to one author are in the list, where an author is quoted from a work published under another name, or where an authoritative statement is made without mention of the author's name. In ordinary cases an author's name is a sufficient indication of the corresponding item in the list.*

## THE DEVELOPMENT OF MODERN GYNÆCOLOGY

GREAT as the progress has been during the last fifty years in every domain of medicine, in no department has it been so marked as in that which embraces the diseases peculiar to women. Indeed, in tracing the developments of modern gynæcology, it is difficult for the student of our times to estimate the value of each claim to progress, and to set a just price on each alleged advance; for it must be allowed that among many brilliant achievements many false starts have been made, and the boasted triumph of yesterday has been ranked among the failures of to-day.

Sir William Priestley, in his address before the section of Obstetric Medicine and Gynæcology, says: "Looking back on forty years of gynæcological practice, I can recollect what has been termed a craze for inflammation and ulceration of the os and cervix uteri. During its prevalence, it was said of some devotees that every woman of a household was apt to be regarded as suffering from these affections, and locally treated accordingly. Shortly afterwards came a brief and not very creditable period when clitoridectomy was strongly advocated as a remedy for numerous ills. This, fortunately, had a very limited currency and was speedily abandoned. Then followed a time in which displacement of the uterus held the field, and every backache, every pelvic discomfort, every general neurosis, was attributed to mechanical causes, and must needs be treated by uterine pessaries. Again we had an epoch when oophorectomy was not only recommended, and largely practised as a means of restraining hæmorrhage in bleeding fibroids, but also as a remedy for certain forms of neurosis, even when the ovaries were healthy or not seriously diseased. Ere long it was discovered that removing the ovaries for neuroses, even if safely accomplished as far as life was concerned, was frequently followed by more serious nervous penalties than those for which it had been used as a remedy; that, in fact, it often entailed a loss of mental equilibrium, and sometimes ended in insanity. Close upon this, again, came an ardour for stitching up rents in the cervix uteri following child-birth, rents which were described as producing many hitherto unknown evils, and frequently conducing to the establishment of malignant disease. Lastly, we have had what has been described as an epidemic of operations for the excision of the uterine



appendages; and even now, though this operation has but recently come into vogue, there is a reaction against its too frequent performance, and a demand in its place for more conservative methods, which shall leave these parts of the generative system a chance of still performing their important functions."

Whatever may have been the mistakes or the delays in true progress, it is, at any rate, pleasant to know that the age of mere speculation and ignorant mysticism has passed; and that the accurate knowledge and fuller certainties of the present day have been won by anatomical and pathological research, and by patient clinical observation both in the sick-room and the operating theatre.

It will always be a pleasant task to acknowledge the deep debt of gratitude which gynæcology owes to Sir Joseph Lister; for without his scientific discoveries and brilliant teaching the successes of modern pelvic and abdominal surgery could never have been won.

The groundwork of all true development in any branch of medical science must lie in the establishment of an accurate knowledge of anatomical detail, and a correct appreciation of pathological changes. It may be well to review the advance of our knowledge in these subjects; and first in anatomy.

**Anatomy.** — *The blood-supply of the uterus*, by the uterine and ovarian arteries, has been well known and described by anatomists for many years past; but the manner in which the blood is distributed to the organ had been less minutely studied: until Sir John Williams wrote his now classical paper "On the Circulation in the Uterus, with some of its Anatomical and Pathological Bearings," our knowledge of this important subject was extremely imperfect. Sir John Williams pointed out that the provision for the flow of blood into and out of the uterus is such, that the process could with difficulty be disturbed by mechanical causes. The entrance and the exit take place at the sides of the organ at numerous points, and not at its extremities; while in the uterus the direction of the current is transverse to its length and perpendicular to its surface: a ligature might therefore be placed round the uterus at any point without affecting the circulation above and below. The only ligature which could materially interfere with the flow of blood into the uterus, or out of it, is one surrounding the broad ligaments (their upper borders being included within it), together with a portion of the uterus. In this case the inflows to the parts above or within the ligature, and the outflows from them, would be diminished or stopped. Conditions similar to this are found when the uterus forms a hernia, either in the inguinal canal or in the canal or pouch of Douglas. When the fundus of the uterus is found in the pouch of Douglas the condition is spoken of as a retroflexion or retroversion; but it is really a great deal more than this: it would be as correct to speak of the condition found when the uterus is in the inguinal canal as antelexion or anteversion. Both are true herniæ, and the symptoms are due in great part to the constriction at the neck of the sac — in posterior hernia by the sacro-uterine ligaments.



There is another condition which may interfere with the return of blood from the uterus, namely, procidentia. Here all the veins of the broad ligaments may be so stretched that their channels may be considerably diminished, and all the channels for the return of blood from the uterus may be so narrowed that the organ must consequently suffer from passive congestion. These two conditions, herniæ of the uterus and great procidentia, appear to be the only displacements of the uterus which can give rise to congestion of the organ.

To those who remember the period in the development of gynæcology when uterine displacements were made to explain endless ills, it will be clear that the publication of the above essay made an enormous difference in the value attributed to so-called mechanical causes. Nowadays a more rational view is taken of the importance of alterations or deviations from the ordinary position of the womb; and it is recognised that very considerable changes in the position of the uterus are perfectly compatible with the enjoyment of excellent health. The outcome on the clinical aspect is easy to imagine; pessaries are no longer recklessly inserted for every slight misplacement, but are retained for those more severe cases in which relief to an embarrassed circulation is clearly called for.

*The Pelvic Peritoneum.*—Good work has been done in the past years by those who have increased our knowledge of the anatomical and obstetric aspects of the pelvic peritoneum. Thus Polk and Barbour have shown that in the full-term pregnant uterus the peritoneum in front and behind has the same relations as in the non-gravid uterus; whereas, at the sides, the peritoneum is so lifted up by the growing uterus that the base of the broad ligament is on the level with the pelvic brim. Stephenson concludes that the ligamental portions of the pelvic peritoneum offer considerable and permanent resistance to stretching beyond the limits of their elasticity; and that the tension thus thrown on them is sufficient to undo their attachment to the pelvic walls. The peritoneum covering the uterus, however, instead of borrowing from neighbouring parts, undergoes a gradual yielding to an unlimited extent—growth supplying the additional material necessary to prevent thinning. The contrast is great between the unlimited expansion of the uterine peritoneum, under the gradual increase in bulk of the ovum and its intolerance of a rapid dilating force—a contrast aptly illustrated in the history of the induction of premature labour by the rupture of the uterus on the injection of but a few ounces of water. The peculiar property of the uterine peritoneum of gradually yielding under a small but persistent force, while breaking under a sudden one, confers upon it something of a plastic character. Dr. Stephenson remarks: “Such being the properties of the serous coat, it is evident that it must play a part in the dynamics of the uterus. It furnishes a part of the persistent pressure inside the organ. It is also capable of taking a share in the retraction of the uterus. Whatever be the state of the muscular fibres of the uterus when labour is over, they are surrounded and supported by

an elastic capsule, with which any force tending to produce dilatation has to reckon. This idea is strongly supported by the anatomical fact that, in the portion of the uterine walls where reaction is manifested, the peritoneum is firmly attached; whereas the parts where no active retraction occurs have either no peritoneal covering, or that membrane is but loosely attached thereto."

The knowledge of this behaviour of the pelvic peritoneum under the disturbing influence of pregnancy is of immense importance to the gynæcological surgeon; for it enables him to estimate the probable changes in the anatomical arrangement of the membrane, when fibroid tumours or broad ligament cysts have developed in the pelvis, and have materially affected the relations of its parts. Again, in the rupture of tubal gestations, or in the formation of pelvic hæmatoma from other causes, the effect of the peritoneal resistance on the development of these swellings is made clear.

*The Connective Tissue of the Pelvis.*—We are greatly indebted to the good work done by Hart and Barbour for our accurate knowledge of the manner in which the connective tissue of the pelvis is distributed. This tissue, lying subperitoneally, surrounding the cervix uteri, and spreading out between the layers of the broad ligament, is of the highest pathological importance, as in it, and in the pelvic peritoneum, occur those inflammatory exudations so common in women.

Of late years our knowledge of the disposition of this tissue has been rendered much more accurate; and, accordingly, our discrimination of pelvic inflammatory attacks made much more precise. The most valuable information is obtained by studying sections of frozen pelvises. This method gives the precise position of the tissue, its amount and distribution. By injections of air, water, or plaster of Paris, we have learnt the varying attachments of the pelvic peritoneum to the subjacent tissue; and the lines of cleavage, as it were, of the pelvic connective tissue along which lines pus will burrow. The valuable experiments of Bandl, König, and Schlesinger have given us the following results:—

1. Water injected between the layers of the broad ligament, high up in front of the ovary, passed first into the tissue lying at the highest part of the side-wall of the true pelvis. It then passed into the tissue of the iliac fossa, lifting up the peritoneum, and followed the course of the psoas, passing only slightly into the hollow of the iliac bone. Lastly, it separated the peritoneum from the anterior abdominal wall for some little distance above Poupart's ligament, and from the true pelvis below it.

2. On injection beneath the broad ligament to the side and in front of the isthmus, the deep lateral tissue became filled first; then the peritoneum became lifted up from the anterior part of the cervix uteri; thence the separation passed first to the tissue near the bladder; ultimately the fluid passed along the round ligament to the inguinal ring. There it separated the peritoneum along the line of Poupart's ligament, and passed into the iliac fossa.

3. An injection at the posterior part of the base of the broad ligament filled the corresponding tissue round Douglas' pouch and then passed on as described in the first section.

Much might be written to show what extensive work has been done to perfect our knowledge of the sectional anatomy of the female pelvis, of the structural anatomy of the pelvic floor, and of the position of the uterus and its appendages; but the work already quoted will illustrate how full a share anatomy has had in the development of gynæcological science.

Turning from the anatomical to the **pathological and clinical aspects**, it is interesting to note that the enormous strides which the science has made, and which have raised it from a desultory collection of hypotheses to its present high position, have all been taken in the last half century. It is true that in the early part of the century Récamier was advocating the use of the speculum and sound, and by his writing and teachings was given an impulse to the study of uterine pathology; but it was not until about the year 1840, when Simpson in England and Huguier in France took the field with so much warmth, vigour, and originality, that interest was awakened and the future of gynæcology assured. Récamier, Lisfranc, Kiwisch, Huguier, Simpson, and others had already paved the way for further discoveries, when Dr. H. J. Bennet, in 1845, published the first edition of his work on *Inflammation of the Uterus*, and roused the attention of the profession in every country to the pathology which he there set forth. The chief points he insisted upon were the following:—

1. That inflammation is the chief factor in uterine affections, and that, as results, there follow from it displacements, ulcerations, and affections of the appendages.

2. That menstrual troubles and leucorrhœa are merely symptoms of this morbid state.

3. That in the vast majority of cases inflammatory action will be found to confine itself to the cervical canal, and not to affect the body of the uterus.

4. That the disease is properly attacked by strong caustics.

It is difficult for the modern student to apprehend the conflict of opinions which arose over these assertions of Bennet; it is sufficient to say that his views were strongly controverted by such able writers as Tyler Smith, Robert Lee, West, and others; and that in the present day few gynæcologists would be prepared to accept such statements without considerable modifications.

Thanks to the study of microbial pathology, much evidence, that in those days seemed misty and conflicting, is read by us now in a totally different sense. The knowledge of septic organisms, the influence of specific microbes, the conditions of tissue-resistances, have opened out for us new ideas and new interpretations; and it is probably not too much to assert that had Dr. Bennet possessed our advantages much of his pathology would have been rewritten.

Another landmark in the history of the development of modern gynæcology was the publication by Dr. Tilt, in 1850, of his book on the subject of *Ovarian Inflammation*; later the same writer put forward the following propositions:—

1. That the recognised frequency of inflammatory lesions in the ovaries and in the tissues which surround them, is of much greater practical importance than is generally admitted.

2. That of all inflammatory lesions of the ovary those involving destruction of the whole organ are rare; while the most numerous, and therefore the most important, may be ascribed to a disease that may be called either chronic or subacute ovaritis.

3. That, as a rule, pelvic diseases of women radiate from morbid ovulation.

4. That morbid ovulation is a most frequent cause of ovaritis.

5. That ovaritis frequently causes pelvic peritonitis.

6. That blood is frequently poured out from the ovary and the oviducts into the peritoneum.

7. That subacute ovaritis frequently initiates and prolongs metritis.

8. That ovaritis generally leads to considerable and varied disturbance of menstruation.

9. That some chronic ovarian tumours may be considered as aberrations from the normal structure of the Graafian cells.

Much of the pathology involved in these propositions of Tilt was sound, and has stood the test of time and more extended research; and though, as in propositions three and four, his teaching is not nowadays accepted, yet by it a considerable stimulus was given to the study of ovarian pathology, and in testing the truth of his assertions more and more light was gained. Morbid conditions of the tubes had been but little studied in Tilt's time, and the relation of tubal disease to ovarian inflammation was hardly appreciated; had tubal pathology been better understood, probably less weight would have been attached to morbid ovulation as a cause of pelvic disease.

The year 1854 marked a fresh epoch in the evolution of gynæcology; then it was that the great war of *uterine displacements* and pessary-manufacture began. Hodge in America, Velpeau in France, and Graily Hewitt in England, stood forth as champions of the immense importance of malposition of the uterus in the causation of pelvic disease. How strongly the theory was urged may be judged by Velpeau's statement: "I declare, nevertheless, that the majority of the women treated for other affections of the uterus have only displacements, and I affirm, that eighteen times out of twenty, patients suffering from disease of the womb, or of some other part of this region, — those, for instance, in whom they diagnose engorgements, — are affected by displacements."

Graily Hewitt, again, showed in his writings and teachings the enormous importance he attached to displacements of the womb; in his well-known work on *Diseases of Women* he formulates the following opinions:—



"1. That patients suffering from symptoms of uterine inflammation are almost universally found to be affected with flexion or alteration in the shape of the uterus; an alteration of easily recognised character though varying in degree.

"2. That the change in the form and shape of the uterus is frequently brought about in consequence of the uterus being previously in a state of unusual softness, or what may be often correctly designated as chronic inflammation.

"3. That the flexion once produced is not only liable to perpetuate itself, so to speak, but continues to act incessantly as the cause of the chronic inflammation present."

For a long time the teaching and literature of this epoch caused a vastly undue importance to be laid on the presence of every flexion or deviation, however slight. Every gynæcologist or practitioner who claimed special gynæcological merit, felt himself called upon to invent a pessary or to modify some one else's instrument; and if, to quote Dr. Clifford Allbutt, "the uterus could justly complain that it was always being impaled on a stem or perched on a twig," it certainly could not complain that there was want of variety in the stem or monotony in the contour of the twig.

Thanks to a more complete study of the circulation of the uterus by Williams, and to the teaching and practice of Matthews Duncan, a more correct appreciation of the importance of uterine displacement has been arrived at; and we can recognise that it is possible for the uterine axis, as for the nasal septum, to be somewhat deviated without the patient's health being materially affected thereby. The value of a pessary in suitable cases is fully allowed; but the instrument is no longer thought to be a panacea for every pelvic ill, or even a justifiable placebo to soothe the patient when diagnosis is at fault.

**Surgery.** — *The next great era in the progress of gynecology dates from the establishment of ovariectomy as a recognised operation; for abdominal surgery, and especially that branch of it which had reference to disease of the uterus and its appendages, received its greatest impulse when it was found that ovarian cysts of the most formidable nature could be dealt with successfully and safely. Much discussion has arisen from time to time as to whom the credit of the first successful ovariectomy belongs, but it is now fairly certain that this honour rightly belongs to Dr. McDowell of Kentucky.*

The record of this first operation is of interest; it was performed on a Mrs. Crawford of Kentucky, in December 1809. The tumour inclined more to one side than the other, and was so large as to induce her professional attendant to believe that she was in the last stage of pregnancy. She was affected with pains similar to those of labour pains, from which she could find no relief. The incision was made on the left side of the median line, some distance from the outer edge of the rectus muscle, and was nine inches in length. As soon as the incision was completed the intestines rushed out upon the table; and so completely

was the abdomen filled by the tumour, that they could not be replaced during the operation, which was finished in twenty-five minutes. In consequence of its great bulk Dr. M'Dowell was obliged to puncture it before it could be removed. He then threw a ligature round the Fallopian tube near the uterus, and cut through the attachments of the morbid growth. The sac weighed seven and a half pounds, and contained fifteen pounds of a turbid, gelatinous-looking substance. The edges of the wound being brought together by the interrupted suture and adhesive strips, the woman was placed in bed and put upon the antiphlogistic regimen. "In five days," says Dr. M'Dowell, "I visited her, and, much to my astonishment, found her engaged in making up her bed. I gave her particular caution for the future, and in twenty-five days she returned home in good health, which she continues to enjoy." Mrs. Crawford lived until March 1841, and had no return of her disease. She enjoyed excellent health up to the time of her death.

It must not, however, for a moment be supposed that the idea of ovariectomy originated with M'Dowell: years before, the Hunters had shadowed forth the possibility of removing ovarian cysts; and John Bell, of Edinburgh, though he had never performed ovariectomy, yet in his lectures dwelt with peculiar force and pathos upon the hopeless character of ovarian tumours when left alone, and upon the practicability of removing them by operation. From this time forward operating surgeons from time to time undertook the operation: sometimes a solitary case, followed by success or failure, sometimes a small group of cases (as published by Dr. Clay of Manchester in 1842) with a fair percentage of success, were recorded; but still the operation had not secured the confidence of the profession, and the records were few and far between.

In 1850 Mr. Duffin inaugurated a new era by raising the question of the danger of leaving the tied end of the pedicle within the peritoneal cavity; and by insisting upon the importance of keeping the strangulated stump outside. Of this step in the history of ovariectomy Spencer Wells writes: "Whatever may be our opinions and practice at the present time, and whatever views we may hold upon the question, whether this extraperitoneal treatment of the pedicle has advanced or retarded the success of the operation, Mr. Duffin's arguments led to great changes and results — to the use of the clamp and to all the modifications of treatment attendant upon it, and ultimately to researches as to the physiological and pathological phenomena of ligatured stumps within the peritoneal cavity, and to the study of the important subject of drainage by Kœberlé and others."

Much might be said of the excellent work done by Baker Brown, and of his success with the cautery; also of Tyler Smith's revival of the practice of returning the pedicle with the ligature: but the history of the established and successful practice of ovariectomy dates from the publication of Sir Spencer Wells's first book in 1864. From this time onward abdominal pelvic surgery has had a continuous story of forward progress,

step by step difficulties have been overcome, and each advance has been established on a sound scientific basis.

Among the many useful points made clear by Spencer Wells that regarding the union of divided peritoneum was of special interest. From experiments made upon dogs, rabbits, guinea-pigs, and other animals, he was able to give visible evidence that, in the union of the cut surfaces of an abdominal incision, however accurately other tissues might be brought together, if the cut edges of the peritoneum are left free within the cavity they retract, direct union does not take place, and secondary evil consequences result. On the other hand, in specimens where the divided edges or rather surfaces of peritoneum have been pressed together, the smooth, serous, inner coat of the abdominal wall is perfectly restored. The stitches cannot be seen on the inside, though plainly visible on the skin; and there is no adhesion of intestine or omentum. But in other specimens, where the peritoneal edges were purposely excluded from the sutures, and the animal was not killed for a day or two, intestine or omentum adheres to the inner surface of the abdominal wall, thus completing the peritoneal sac at the great risk of intestinal obstruction; to say nothing of a want of firm parietal union and subsequent ventral hernia. It was clearly demonstrated that, when skin or mucous membrane is divided, the edges must be brought together to secure direct union. If they are inverted, union is prevented. The exact opposite holds good with serous membranes. Their edges should be inverted and two surfaces of membrane pressed together, so that the sutures are not seen. The effused lymph then makes so smooth a surface that even the line of union cannot be seen.

To those of us who have been brought up in the atmosphere of modern surgery, when the details of ovariectomy are carried out with almost universal agreement, it is difficult to realise the fierceness of the fights which raged round the comparative merits of a long or a short abdominal incision; how bitterly the advocates of the intraperitoneal treatment of the pedicle regarded those who treated the pedicle by the extraperitoneal method and the use of the clamp, or how great was the importance attributed by each operator to his own special method of closing the wound! Bit by bit evidence has been accumulated as to the desirability of using opium freely or sparingly after the operation; as to the best mode of feeding the patient and maintaining her strength; as to the use of stimulants; the modes of entry of septic poisoning, and the after consequences and complications of the operation.

Ovariectomy in the course of its evolution taught us great things regarding the tolerance of the peritoneum even of rough handling and injury, provided nothing septic be left for absorption. Many details of treatment employed at present in abdominal surgery were learnt in the school of ovariectomy. In his address on "Abdominal Surgery Past and Present," delivered before the Medical Society in October 1890, Mr. Knowsley Thornton attempted to sum up the causes of slow progress and too frequent failure in abdominal surgery up to the year 1876, and to place the various



causes in what seemed to him to be their order of importance. He says: "We have first the general want of cleanliness and the lack of all appreciation or knowledge of what constituted surgical cleanliness, then the long ligature and the clamp, both clumsy and unscientific, and both specially suited to make the want of cleanliness more deadly, and then following with an appreciable but far different influence, we have delay in operating, tapping, and the long incision. Then I must not forget drainage, for I think it is highly probable that a really good system of drainage, such as we now have, thanks to Kœberlé and Keith, would have done much to counteract the evils I have named above, though the frequent use of the drainage tube, with the long ligature and the clamp, would have introduced new elements of risk, which I shall have to refer to again when I speak of the place which drainage occupies in the successes of to-day."

Probably the long ligature and the clamp had less to do with failure than the want of knowledge of antiseptic precautions. At the present day we use a clamp round the pedicle of a fibroid tumour, we fix it in the lower angle of the abdominal wound, and yet we keep the wound and peritoneum perfectly free from septic mischief: moreover, in extirpation of the cancerous uterus per vaginam we tie broad ligaments with silk ligatures, and leave long ends hanging down into the vagina till they come away; and yet we do not get septic peritonitis.

Probably delay in operating plays a more important part in results than we have hitherto supposed. The early ovariologists had to undertake a large percentage of cases of long standing, cases in which the patient's strength had been exhausted by years of suffering, and in whom tissue resistance to the slighter or more severe forms of septic attack was greatly impaired; cases, moreover, in which dense and difficult adhesions to bowel, bladder, liver, and neighbouring parts had become organised in the long delay. At the present time the majority of these difficult cases have been cleared off, and in most of the cases now undertaken the health is still unimpaired, and adhesions (if present) are soft and easily separated; moreover, long experience has taught us how to discriminate unsuitable cases of a malignant type, and these we have the wisdom to leave severely alone.

No educated surgeon will ever minimise our vast obligations to Sir Joseph Lister; but, in fairness to the early operators, we may notice that Sir Spencer Wells had taken steps at a very early period to prevent the exposure of his cases to noxious influences. He did not allow surgeons who had been in contact with septic cases to be present at his operations; he kept his wards for abdominal cases separate from wards in which patients with uterine sloughing cancer or other fœtid diseases were present; and he himself gave up all work in the post-mortem room. The dawning of better things in the way of surgical cleanliness had thus been shadowed forth before the full light of Lister's teaching had risen upon us. If in describing thus far the growth of ovariectomy the names of many eminent pioneers, such as Clay of Manchester, Atlee of America, Keith, and numerous other workers have received scanty recognition, it is because in the present article no attempt is being made to describe



fully the evolution of ovariectomy, but only to show the place it took in the development of gynæcological science, and to emphasise some of the principal teaching and the elaboration of details which secured for it the present successful position.

When once the removal of the ovaries in cases of cystic disease of these organs had become an established operation, it was to be expected that surgeons would consider the advisability of removing the uterine appendages for other morbid conditions: but no special move was made in this direction till about the year 1872, when we find that Hegar, Battey, and Lawson Tait all began to work in this special field. Battey's original idea was to remove ovaries, not in themselves diseased, for the cure of certain nervous diseases, which he believed to be caused or kept up by structural or functional derangements of the ovaries. Hegar must have the credit of introducing the removal of ovaries for the cure of fibromyoma of the uterus; while to Mr. Lawson Tait belongs the credit of introducing the operations for removal of diseased ovaries and tubes.

It is now fairly well established that extirpation of the ovaries for various neuroses is practically a failure: the operation has been recommended in cases of insanity occurring at times of ovulation, in cases of hystero-epilepsy, also in hystero-neuroses other than epilepsy of severe character, but in very few instances has a cure been reported; in the majority no good has been gained, and in a certain proportion the patient has been left mentally and physically in a worse condition than before.

When, on the other hand, we study the cases in which the ovaries have been removed for the cure of uterine fibromyoma we find that a great step has been gained, and that Professor Hegar has added a valuable resource to our treatment of these tumours. Knowsley Thornton considers that we owe an immense debt to Hegar for the introduction of this method of dealing with fibromyomas; that the operation has, of course, its risks and its failures, but that, with care in the selection of proper cases, and with care in the removal of every particle of ovarian tissue, it is most satisfactory in its results, and is one of the most thoroughly scientific and valuable operations in the field of abdominal surgery. When we come to consider the removal of diseased ovaries and tubes, as recommended by Tait; and try to gauge the degree in which this operation can be called an advance in gynæcology, we have a difficult question to deal with—a difficulty mainly owing to the intemperate zeal of many advocates of the operation. In cases in which tubes are filled with putrid or specifically diseased pus, and are displaced and badly adherent; or, again, when an ovary has become a mere bag of pus, displaced, and fixed by adhesions low in the pelvis, operation is urgently called for and should be undertaken.

There are cases, also, in which the ovaries, for a long time the subject of chronic inflammation, may be displaced and adherent low in the pelvis; cases in which the tubes may be slightly thickened by mucoid degeneration, or are in an early condition of hydrosalpinx: in such cases

when the patient is drifting into chronic invalidism, is incapacitated from work, and is unequal to the duties of life, extirpation is certainly called for. On the other hand, to remove ovaries and tubes for early stages of sub-acute ovaritis, for slight degrees of pelvic peritonitis affecting the end of the tube and the ovary, for minor degrees of salpingitis, for ovarian prolapse apart from coarse disease, is to bring the operation into well-earned disrepute, and to retard rather than to advance the progress of the science. It is, unfortunately, in the very cases in which the operation is most necessary that the greatest danger arises; for it is impossible to extirpate tubes full of foul pus or suppurating ovaries without great danger of fouling the peritoneum: moreover, in these cases the intestines are often so adherent, or so softened by inflammation, that a great risk of rupture or of subsequent faecal fistula must necessarily be run. It has been well said that if the mortality could be obtained for all the cases of pyosalpinx operated upon in the United Kingdom since Tait introduced the operation, it would run the natural mortality of the disease very close indeed. There are, moreover, sundry objections to the operation which should be recognised, though they are frequently ignored. The operation does not by any means always lead to a permanent cure: a large proportion of patients operated upon suffer from continuance of the pains which preceded the operation; sometimes inflammatory products are formed which press on nerves and thus cause fresh troubles, or fix the uterus and thereby cause intense pain; or grave mental symptoms may ensue; or the pedicle may suppurate and the healing of the wound be gravely delayed.

Mr. Alban Doran summed up the position of the operation very satisfactorily when he remarked that it was very evident that removal of the appendages was an operation to be avoided whenever possible: and Professor Sinclair has wisely pointed out that operators are disposed to regard the woman's escaping with her life as constituting *per se* a satisfactory result; whereas more attention should be paid to the ultimate effects upon the general health.

In connection with this operation, we may properly consider the work done of late years both in Germany and in England, by which it has been shown that in many instances the mere breaking down of adhesions, without removal of either tube or ovary, is quite sufficient to relieve the patient of all her previous symptoms, and to restore her to an active, useful life.

The revival of ovariectomy between 1858 and 1865 led, in the words of Paget, to an extension of the whole domain of peritoneal surgery. This extension, naturally enough, began with the *removal of the uterine tumours*. The removal of fibromyomas of the uterus has always been a much more serious matter than the performance of ovariectomy: thus up to the end of the year 1883, or thereabouts, such eminent operators as Schroeder, Martin, Tait, and Bantock had a mortality of 30 per cent, or even higher; and though by improved methods and wider experience Keith has shown that it is possible to have a mortality not much greater

than that of ovariectomy, still the operation in the hands of the majority of surgeons has not given such satisfactory results. The greatest gain so far has been brought about by Hegar's suggestion of the removal of tubes and ovaries as a method of procuring arrest of growth and subsequent atrophy of these growths.

The rising generation of medical students is much more efficiently trained in obstetrics and gynæcology than was the case twenty years ago; and, doubtless, as fibroids of the uterus are recognised earlier, and cases of rapid growth of them are better watched and understood, Hegar's method will be applied in suitable cases with less delay, and at a time when removal of the uterine appendages is more feasible. We may thus hope less frequently to see large fibroid masses filling the abdomen and calling for abdominal hysterectomy with its greater mortality.

It is not within the scope of this article to enter upon the various methods of operating for uterine fibroids, nor upon the various modifications of existing operations; but it is noteworthy that the most eminent gynæcological surgeons of the present day are not the most ardent advocates of frequent operating, and show their skill rather by their judicious selection of cases suitable for interference. Again, there is a decided tendency to prefer removal by abdominal section to any form of vaginal operation; save in cases where submucous fibroids have already been partially delivered. As to the treatment of the pedicle of the tumour, when the growth is removed by abdominal incision operators are still divided in their choice between the extraperitoneal method and the intraperitoneal as advocated by Schroeder. Probably it will be found that each method has its advantages, and that the choice of method must be decided rather by the nature of the growth than by the fancy of the operator. While on the subject of fibromyoma of the uterus, it is impossible not to refer to the electrical treatment of fibroids which has been brought forward by Dr. Apostoli during the last few years. Many years ago it was asked whether fibroid tumours could be dispersed by the use of the galvanic current, but no satisfactory reply could be obtained. Apostoli has come forward claiming that he has found a means of applying currents so strong that destruction and shrinkage of the tumour is obtained without any damage to the patient's healthy tissues. According to his method, the operator applies a large clay pad over the abdomen in which is embedded the positive pole of a galvanic battery; then a sound, made of platinum with the lower part protected by some insulating covering, is passed through the cervix into the uterus; or, where this is impossible, a sharp-pointed steel sound, with all but the terminal half inch insulated by a protective coating, is plunged through the vaginal wall into the substance of the tumour: the connections are now made, and a current, varying from 50 to 100 milliampères or more, is allowed to pass. With reasonable care currents of this strength can be used without any damage to the wall of the abdomen. Many cases were brought forward by Apostoli to show us that under

this treatment fibroids commonly shrink down to half or a third of their original bulk, and in many instances are practically destroyed without any sloughing or suppuration. The method has been fairly tested by numerous operators since its introduction, and it is to their results that we must look in deciding whether this electrical treatment of fibroids is to be regarded as an advance in our knowledge and modes of treatment or not. So far as can be decided at present, the result of the most recent inquiries has led us to the following conclusions:—

1. The majority of fibromyomas (especially those of slow growth) are not reduced by the treatment.

2. Soft fibromyomas are somewhat reduced in size by the use of the current.

3. Hæmorrhage due to submucous fibroids, or perhaps to the fungous endometritis so often associated with them, is greatly lessened. In these cases the positive pole is introduced into the uterine cavity, and the negative is connected with the abdominal pad.

4. Considerable damage may be done to tissues in using this treatment.

The opponents of Apostoli's method have pointed out that fibroid tumours of the uterus (especially the soft cellular form) may be reduced quite as satisfactorily by the use of rest, hot douches, and ergot, as by the use of electricity; and with much greater safety. Also that the shrinkage obtained by the use of the current is by no means permanent. Again, as regards hæmorrhage, the happiest results often follow the use of dilatation and curettage, so that there is no special advantage in employing the electrical treatment. Keith and other observers have spoken in terms of warm commendation of Apostoli's work, but so far they have not brought forward results which carry general conviction. More extended observation is needed, but at present it can hardly be said that the electrical treatment of fibromyoma of the uterus ranks high among our gains [*vide art.* "The Electrical Treatment of Diseases of Women"].

*Extra-Uterine Pregnancy.*—One of the results of the recent advances in abdominal surgery has been to give us a wider acquaintance with the pathology and treatment of those interesting cases in which the fœtus is developed outside the uterine cavity. Much of our present knowledge is due to the investigation of Mr. Lawson Tait. Since Tait's first operation in 1883 for ruptured ectopic gestation—an operation which he performed successfully—great attention has been directed to the subject, and much advance in our knowledge has been made. Before this epoch extra-uterine gestation was thought to be one of the rarest events in the pathology of pregnancy: now we know that the accident is one of common occurrence. The older text-books taught much that was purely hypothetical on the subject; thus they recognised a variety in which conception was affirmed to occur in the Graafian follicle, and development to take place entirely in the ovary. Tait pointed out that no museum specimen or post-mortem record gives any ground for such a view.

Again, regarding the so-called abdominal form of ectopic gestation, it



was believed that an ovum might be fertilised, drop into the peritoneal cavity on its way to the tubal opening, and grow from its beginning free in the peritoneal cavity. Without saying that this is impossible, we may assert that in our present state of knowledge the notion is purely imaginary, and is not borne out by any evidence of dissections. More extensive research and observation has led us to view almost every case as primarily tubal, commencing either—(i.) In the fimbriated end of the tube; or (ii.) in the centre of the tube; or (iii.) in the interstitial part of the tube.

Much light has been thrown on the etiology of blood tumour in the pelvis by abdominal sections undertaken for ruptured tubal gestation: and now it is clear that the majority of pelvic hæmatoceles and hæmatomas are due to blood poured out from the end of the tube after rupture of the gravid tube or separation of the sac wall: in a few cases only can it be traced to such other causes as reflex of menstrual blood, hæmorrhagic peritonitis, rupture of veins in the broad ligament, and the like. No great advance has been made in our knowledge of the causes which lead to the production of an extra-uterine gestation; but the hypothesis which has gained the widest hearing is that it is due to some lesion in the interior of the tube which obstructs the ovum in its passage to the uterus. This lesion is in some cases a desquamation of the epithelium of the tube, whereby the cilia are removed, and a pouching of the tube may be produced in which the ovum remains instead of continuing its journey to the womb. In other cases a stenosis of the lumen of the tube is brought about by peritonitic adhesions which, in the course of their contraction, produce an angular bend in the tube, and so arrest of the ovum. The theory of lesion in the interior of the tube seems to cover a large number of cases; and it is strengthened by the fact that a history of previous trouble on the same side of the pelvis can frequently be elicited. The event is often, though not always, preceded by a period of sterility. The theory is also supported by the further supposition that the normal site of impregnation is in the uterus, and that if the ovum be delayed, and impregnated in the tube, ectopic gestation results. Cases of ruptured tubal gestation, when examined on the post-mortem room table or during an abdominal operation, have taught us to what an extreme degree the ruptured peritoneum may be lifted from the pelvic walls and viscera by the gradual development of the fœtus, or by repeated hæmorrhages beneath the membrane. This elevation may reach as high as the umbilicus or even further.

In a paper read before the Royal Medical and Chirurgical Society of London, Mr. Bland Sutton drew attention to the fact that the ovum in a case of tubal pregnancy, like the ovum in uterine pregnancy, is liable to become converted into a mole (apoplectic ovum). In November 1892 the same author brought a communication on "Tubal Moles and Tubal Abortion" before the Medical Society of London, and by his admirable drawings and accurate research added greatly to our knowledge of this important condition.

On the subject of tubal moles Bland Sutton says: "The retention of an impregnated ovum in the Fallopian tube leads to occlusion of the abdominal ostium, an event usually complete by the sixth, but often delayed to the eighth week following impregnation. It is therefore comparatively a slow process. When the ovum is lodged in the ampulla of the tube the ostium cannot close. So long as the tubal ostium remains open the ovum is in constant jeopardy of being extruded through it into the peritoneal cavity, especially when the ovum lies near or in the ampulla of the tube. When an impregnated ovum is thus extruded from the tube into the general peritoneal cavity, it is invariably in the condition of a mole, and the accident is always accompanied by hæmorrhage. The extrusion of a mole in this way is always indicated by the term 'tubal abortion.' Free hæmorrhage may occur from a gravid tube and the mole be still retained in consequence of its attachment to the wall of the tube. Under such conditions the bleeding may be repeated. This is known as 'incomplete tubal abortion.'"

Since the discovery of the tubal mole, specimens of occluded Fallopian tubes filled with blood, independent of tubal pregnancy, are now found to be infrequent. In the last report of the Museum of the Royal College of Surgeons (1892), a description is given of "An unequivocal example of Hæmatosalpinx." This is a fair indication of the revolution which has taken place in our knowledge of the early stages of tubal pregnancy. There is one point in the treatment of ectopic gestation, advanced to term and in which the fœtus is still living, which requires further study, and this is the treatment of the placenta after incision of the sac and extraction of the child. To strip off the after-birth from the underlying tissues would usually involve a terrible hæmorrhage and probably the death of the patient; yet to leave the placenta means, in too many instances, secondary septic changes and the death of the mother. Lawson Tait has recommended that the cord should be cut off close to the placenta, the sac washed out, and then sealed by stitching it over the placenta; the abdomen is then to be closed, and the after-birth left to be absorbed.

The establishment of ovariectomy, leading as it did to the great extension of peritoneal surgery, has led us to another great advance, namely, to the recognition of the benefits of abdominal drainage. Operators differ greatly in their estimate of the value of the drainage tube in abdominal surgery, but few in the present day will be found to deny its value in suitable cases. Whether in the treatment of pelvic abscess, in the case of suppurative or tubercular peritonitis, or again after the removal of fœtid, closely adherent pelvic cysts, the drainage tube becomes of primary importance. For some time the question was debated whether an incision made into the vaginal roof to allow of a canula being drawn through from the peritoneal cavity into the vaginal canal were not the better method of drainage; but it has been fairly well proven by Keith, Alban Doran, and other authorities, that the cavity of the peritoneum can be more effectually emptied and kept free of exuded fluid by

the glass drainage tube passed down from the abdominal wound into the floor of Douglas' pouch. Of course in some cases the use of the rubber tube or of iodoform gauze may possess a special advantage. No one who has witnessed the good effects of abdominal drainage will doubt that in the recognition of this surgical expedient we have made a distinct addition to our surgical knowledge.

No account of the work done in the development of gynæcological science would be complete without a reference to the splendid achievements of Marion Sims in the field of *vesico-vaginal fistula*. In numbers of women life was rendered one long period of suffering and distress until Sims brought his skill to bear on the subject of these lacerations. It is not difficult to picture the constant mental agony of a young woman, still in the prime of life, in whom the discomfort due to incontinence of urine and the factor depending on clothes soaked with decomposing urine were horrors from which she could never escape. From the days of Ambrose Paré attempts had been made by Lallemand, Roux, Gosset, Jobert de Lamballe, and many other surgeons, to find a satisfactory mode of closing these fistulas; but with what amount of success may be judged by the words of Velpeau, who, writing in 1839, says: "To abrade the borders of an opening, when we do not know where to grasp them; to shut it up by means of needles or thread, when we have no point apparently to secure them; to act upon a movable partition placed between two cavities, hidden from our sight, and upon which we can scarcely find any purchase, seems to be calculated to have no other result than to cause unnecessary suffering to the patient."

In 1852 Sims brought out his perfected method of healing these rents in the floor of the bladder; and gained a series of successes which entirely altered the aspect of this special domain of surgery. He laid claim to three discoveries; namely, that he had produced a speculum which enabled an operator to explore the vagina perfectly; that he had found a suture, which was not liable to set up inflammation or ulceration; and that by the use of his catheter, the bladder could be kept empty during the healing of the fistula.

Sims was shortly afterwards followed by Simon of Germany, and to the efforts of these two workers we owe our present satisfactory knowledge of the subject. Simon himself laid great stress on the importance of the operation called by him *kolpokleisis*, or closure of the vagina—an operation to be resorted to in cases in which the cure of a vesico-vaginal fistula could not be successfully accomplished. Doubtless such a surgical resource may be found valuable occasionally; but the cases must be rare in which the fistula cannot be closed by patience and perseverance. Year by year, however, fewer cases of these fistulous openings occur. Better hygienic surroundings have told favourably on the young girls of the present day, and pelvic contractions are less frequent; the frequent use of the midwifery forceps and their earlier application, prevent the fetal head from resting so long on the mother's soft parts, and prevent the sloughing of her anterior pelvic tissues; and an increased knowledge of

the **mechanism of delivery** has led to a more successful management of difficult labours.

Reference may be made here to certain plastic operations which have been devised in connection with the vagina; for instance, plastic operations for lessening the calibre of the vagina, others for preventing prolapse of the uterus, plastic operations on the cervix, and so forth, but none of them has taken a very firm hold on the surgical world. In the same category might be placed sundry operations which have been devised of late years for fixing the uterus; thus Alexander's operation of shortening the round ligaments in cases of uterine prolapse, hysteropexy or fixation of the womb to the posterior surface of the parietal peritoneum, detachment of the vagina from the anterior wall of the uterus with opening of the anterior peritoneal *cul-de-sac*, and forward fixation of the uterus — these and sundry other operations have all their earnest advocates, but I have not given them a recognised place in uterine surgery; for it cannot be said as yet that they have secured the confidence of the gynecological world; they are rather on their trial than accepted as proven remedies.

**Malignant Diseases.** — The ancient writers were doubtless acquainted with cancer of the uterus, but their knowledge was narrowly limited; and we may certainly claim that in the last fifty years we have made great advances in our knowledge of the pathology and clinical course of malignant diseases of the female genital organs. It is a matter of extreme regret that we have hitherto made so little progress in our modes of treatment, and are still so far from an acquaintance with any curative method.

Even in the earlier part of the present century the knowledge of uterine cancer was very shadowy; for Church, writing in 1864, says: "If we compare the writings of different persons, and those men of great experience, we shall find many points of interest undetermined, and others the subject of incessant controversy. Very frequently the description of the disease conveys only a lively picture of the uncertainty of the writer; and so vague, indeed, is the sense in which the term cancer is sometimes applied, especially by the French authors, that it would be quite impossible to recognise the complaint from their description." Denman fully appreciated the uncertainty of the description generally given. He says: "Of cancer it is to be lamented that we have at present neither a tolerable definition nor a correct history, nor any accurate distinction of the several varieties which are certainly known to exist. Nor is it yet proved whether cancer of any part has any specific quality according to the structure of the part affected; nor have we, in fact, any other idea than that it is an incurable disease. Till within quite recent years cancer was often confounded with fibroid tumour of the uterus, and the division into schirrus, encephaloid, epithelioma, and colloid was commonly quoted in the text-books of the day. Moreover, the term 'corroding ulcer' was applied by Dr. John Clark, and subsequently Sir Charles Clark, to a form of ulcer of the cervix in which nothing but rapid destruction of tissue is noticed as a pathological lesion; in which there



is no hardness of the part affected, no induration nor inflammation of surrounding organs — nothing but molecular death in the cervix uteri, and disappearance of its structure as by liquefaction. It has been described under the names of rodent ulcer, diffuse ulcerative cancer, epithelial cancer, and canceroid of the uterus." Many other authors might be quoted to show how little certainty existed.

A decided step in advance was taken when Thiersch and Waldeyer laid down that all cancerous disease in the uterus takes its origin from the epithelium lining glands which dip down into the parenchyma. "Only Thiersch, and recently Waldeyer," says Billroth, "maintain as I do the strict boundary between epithelial and connective tissue cells. I only call those tumours true carcinomata which have a formation similar to that of true epithelial glands (not the lymphatic glands), and whose cells are mostly actual derivatives from true epithelium." At one time surgeons were doubtful whether malignant disease arose more often in one part of the uterus than in another; but another advance was made when Sir Charles Clark wrote that "carcinoma particularly affects glandular parts, and the cervix of the uterus being the most glandular part of it, is probably the reason why it becomes more liable to this disease than any other part of the viscus."

Before this time Dr. Burns had laid down in his work that "as opportunities are not frequent of examining the womb in the early stage of the disease, and as in course of time it involves parts not at first affected, we have not yet decided what the comparative liability of different parts of this viscus is to the disease." Virchow advanced our knowledge still further by his investigations into the differences between malignant cauliflower excrescences and non-malignant papilloma. He stated his belief that some tumours, in every respect resembling vegetating epithelioma, are really non-malignant papilloma. The difference between the latter and real epithelioma is to be found by microscopic examination of the submucous tissue, which in the one case is healthy, in the other case diseased. In 1888 Williams published his well-known Harveian Lectures on uterine cancer, and summed up fairly the extent of our present knowledge.

Three varieties of malignant disease affect the uterus — sarcoma, carcinoma, and adenoma. In the uterus sarcoma and carcinoma are always malignant; adenoma often, but perhaps not always. The uterus is divided into three parts, mainly according to the character of the epithelium and of the glands met with in each part. The first is the vaginal portion: this portio vaginalis is really a cup of stratified epithelium, resembling a tailor's thimble, which fits on the lower end of the cervix proper. The next part is the cervix, and the third is the part above which constitutes the body and fundus of the organ. These divisions are of importance because cancer may begin in any one of them, and the disease generally presents different characters, runs a different course, and is amenable to treatment in different degrees, according as it begins in one or other of them.

In the first division the disease is almost always a squamous

epithelioma. In this case the lines of growth are not towards the cavity of the uterus, but outwards and downwards towards the vagina; it creeps towards the vaginal vault, and then down along the surface of the vaginal walls. There is no evidence that laceration of the cervix plays any part in the etiology of this form of cancer; but most of the cases occur in women who have borne children.

In the second division we find disease occurring with much greater frequency. The starting-point of the cancer of the cervix seems to be always in the glands of the cervix; and if we study the lines of growth of the disease, we find that it usually spreads downwards and outwards into the surrounding cellular tissue. The vaginal walls are usually spared.

In the third division we have cases of cancer of the body of the uterus. This part of the uterus is much less commonly the seat of the disease than is the cervix; at one time, indeed, it was doubted whether cancer ever originated primarily in the body, but numerous undoubted cases have been brought forward to prove the statement. All cancers of the body seem to be of the columnar epithelioma kind. They occur most often after the age of fifty; they give rise at an early period to much pain and flooding; they are more common in nulliparous patients, and, once begun, they involve the whole surface of the body, though they tend to respect the cervix. In the later stages the disease passes through the internal os and attacks the cervix; it also spreads deeply, involves the muscular wall, and may pass through it.

No description of the evolution of this subject would be complete without reference to the admirable work done by Ruge and Veit in investigating the true nature of granular erosions of the cervix, and in showing how these lesions differ from early manifestations of true cancer. An erosion differs from cancer in that the epithelium on its surface and lining its glands consists of a single layer and assumes no aberrant forms; and from adenoma of the cervix, in that the glands are comparatively superficial. A simple erosion, again, bleeds less readily when touched than does the early ulceration of commencing malignant growth.

As regards the treatment of uterine cancer but little can be said. During the last ten or fifteen years a considerable controversy has been raised concerning the rival merits of supravaginal amputation and total extirpation in cases of cervical carcinoma. Most authors are agreed that removal of the cervix is sufficient when the portio vaginalis alone is affected; but there is not the same agreement when the disease attacks the upper part of the cervix. Martin of Berlin and Fritsch of Breslau have published numerous cases of total extirpation of the uterus for cervical cancer; but their reports, and those of other skilful operators, have only demonstrated that the operation can be done by experienced surgeons with a very low rate of mortality. Williams argues that in cases of cervical carcinoma supravaginal amputation does all that is needful, and that no advantage in the prevention of recurrence of the growth is gained by the larger operation. His views, however,

have by no means met with general acceptance by the profession; and the opinion seems to be gaining ground that if, in a case of cancer of the true cervix, an operation be recommended, total extirpation will probably give the best result. Attempts at progress are being made at present principally in the direction of early diagnosis; and surgeons are endeavouring, by microscopical examination of scrapings removed with the curette, or of sections taken from the suspected cervix with knife or scissors, to gain early and certain knowledge while the disease is still narrowly limited and surrounding tissues not invaded.

*Sarcoma Uteri.*—Very little was known about this affection by the early authors of this century. Reference is found in gynæcological literature from time to time to certain forms of fibroid tumours which had a tendency to return after removal; and the term “recurrent fibroid” was often used. Sir James Paget put these tumours into three divisions, namely, (i.) malignant fibrous tumours, (ii.) recurrent fibroids, (iii.) myeloid tumours. Lebert described them as fibro-plastic tumours and Rokitsansky gave them the title of fasciculated cancer. Virchow was the first to give a clear and intelligent description of these growths, and to put them under the head of sarcoma. Gusserow and other observers in Germany, following on the steps of Virchow, have of late years given careful study to uterine sarcoma. Resembling, as it does, cancer of the uterus in many respects, there are certain well-established points of clinical distinction between them. At one time it was thought that the disease always arose in the body of the uterus, and never began primarily in the cervix; but this has now been shown by Veit and others to be a mistake, though of course the large majority of cases are of the former variety. Primary sarcoma of the uterus occurs anatomically and clinically in two distinct forms, namely, (i.) fibro-sarcoma, which forms a more or less firm, circumscribed, rounded tumour growing from the uterine parenchyma; and (ii.) diffuse sarcomatous tumours growing from the connective tissue of the uterine mucous membrane, and composed mostly of small round cells.

Between diffuse sarcoma and carcinoma of the fundus the diagnosis has to be made almost entirely by the microscope. While we have still much to learn regarding malignant affections of the genital organs, we may congratulate ourselves that our knowledge has become more definite, better founded, and more concise. We may here notice that much knowledge has been gained by a more frequent use of cervical dilatation; and in this respect much gratitude is due to Professor Hegar for his admirable mechanical dilators. It is true that dilatation and curettage were practised in the days of Récamier, but not to any considerable extent. So long as surgeons had to trust to slow dilatation of the cervix with tents, and had to consider the risks of septic inflammation consequent on the use of this mode of opening up the cervix, the operation was comparatively seldom resorted to; but the present method of rapid dilatation has removed much of the difficulty, and has enabled us to explore the cavity of the uterus quickly and safely. In cases of hæmorrhage occurring at

or about the time of the climacteric, cases in which the uterus is found by bimanual examination to be distinctly enlarged, this method of exploration is of immense service; for it enables us with the curette or the finger to remove small portions of the hypertrophied mucous membrane, and to determine promptly by the microscope whether the tissue be malignant. Believing, as now we do, that some forms of malignant growth have what may be termed a precancerous stage, it becomes of immense importance to ascertain the character of the disease at an early period.

No great advance has been made in our knowledge of malignant affections of the vagina and vulva; but the paper of Dr. Matthews Duncan on lupus of the vulva, published in the 27th vol. of the *Transactions of the Obstetrical Society of London*, has materially advanced our knowledge of this rare disease. In this communication Duncan pointed out that though vulvar lupus lacked many of the histological characters of lupus vulgaris, yet in its tendency to erode and destroy it closely imitated the latter disease. Lupus included ulceration, inflammation, and hypertrophies, variously combined; states which were not cancerous, not epitheliomatous, and not syphilitic. It may turn out that several diseases are included in this comprehensive term; but at present they are combined in one description on account of their apparent similarity. They are far from being so uncommon as is sometimes supposed.

**Pelvic Inflammation.**—In endeavouring to trace the development of our knowledge regarding acute inflammations occurring in the pelvis, we may date our researches from the year 1840 or thereabouts. Before this time, though abscess of the womb had been mentioned by such early writers as Aetius and Paul of Ægina, yet no systematic study of the affection had been made. However, after the year 1840 many observers were at work. Thus in 1841 Bourdon had written on “Fluctuating Tumour of the True Pelvis”; Doherty in 1843 had given us his views on chronic inflammation of the uterine appendages; Calvi in 1844 had described “Intrapelvic Phlegmonous Abscess”; while in the same year Churchill and Lever had contributed to our knowledge of the subject. A little later, in 1846, Nonat was doing good work in the same field. Any one, however, who reads the medical history of these times will see clearly that the gynæcologists of those days were under the impression that all the pelvic exudations or abscess sacs were solely due to inflammation, or maybe to suppuration, occurring in the cellular tissue of the true pelvis. Such terms as pelvic abscess, peri-uterine phlegmon, parametritis, and pelvic cellulitis, all meant practically the same thing, namely, connective tissue inflammation. The first advance in our knowledge came through Bernutz: in 1857 a case of so-called peri-uterine phlegmon came under his care and the patient died. At the post-mortem examination the pelvic tumour which had been supposed to be formed by inflammation of the pelvic cellular tissue was found to consist of bladder, uterus, broad ligaments, and sigmoid flexure all matted together. The cellular tissue of the broad ligament and uterus



was not involved, and no real peri-uterine phlegmon existed. The study of this and similar cases caused Bernutz and Goupil about the year 1862 to publish their classical memoir, in which abundant clinical and post-mortem evidence was brought forward to prove the true nature of the swellings previously ascribed solely to the effect of pelvic cellulitis. Bernutz summed up his views as follows:—

1. That inflammation of the pelvic peritoneum is a disease very commonly met with.
2. That the tumour found after death in cases of pelvic peritonitis is formed by the matting together of various pelvic viscera as a consequence of this inflammation.
3. That inflammation of the pelvic serous membrane is always symptomatic, and that it is generally symptomatic of inflammation of the ovaries or of the Fallopian tubes.

Old theories, however, die hard; and, though Bernutz had brought forward such abundant proof in support of his assertions, yet for many years his views met with little general acceptance by the majority of gynæcologists, and the old views continued to be taught and held. Even such a keen observer as the late Matthews Duncan thought that Bernutz had been over-zealous in estimating the comparative frequency of pelvic peritonitis and the rarity of pelvic cellulitis. For some years opinions were strongly divided upon the comparative frequency of cellulitis and peritonitis. With the narrowness and bitterness born of imperfect knowledge, some authors laid down strongly that in pelvic peritonitis cellulitis only exists as a complication; while others were as ready to assert that cellulitis is in all instances the primary affection, and that the inflammation only spreads secondarily to the peritoneum. Writing in 1880 Dr. Gaillard Thomas, however, records his conclusions under four distinct propositions, namely:—

- “1. Peri-uterine cellulitis is rare in the nonparous woman, while pelvic peritonitis is exceedingly common.
2. A very large proportion of the cases now regarded as instances of cellulitis are really cases of pelvic peritonitis.
3. The two affections are entirely distinct from each other, and should not be confounded simply because they often complicate each other; they may be compared to serous and parenchymatous inflammation of the lungs—pleurisy and pneumonia. Like them they are separate and distinct, like them they affect different kinds of structure, and like them they generally complicate each other.
4. They may usually be differentiated from each other, and a neglect of the effort at such thorough diagnosis is as reprehensible as a similar want of care in determining between pericarditis and endocarditis.”

Again, in 1886, Hart and Barbour state that there is now little doubt that Bernutz and Goupil pushed their views too far; and that in America, Germany, and Britain gynæcologists now consider pelvic inflammation as both peritonitic and cellulitic. Moreover, they note that both diseases are always combined. Thus in a marked pelvic peritonitis there is always some pelvic cellulitis, and in a marked pelvic cellulitis there is always some pelvic peritonitis. This is quite analogous to what is found in pneumonia and pleurisy. Thus we may fairly

conclude from the result of modern investigations that inflammation both of the cellular tissue and also of the serous membrane may arise, but that of the two the latter is certainly the more frequent.

Much good work has been done of late years in developing our knowledge of the causation of pelvic cellulitis and peritonitis. In the case of the former disease recent investigations go far to show that the introduction of septic particles into the lymph circulation, by way of rents after operation, abortions, or full-term deliveries, is most commonly the cause of the mischief. Many good observers would go so far as to say that they know of no possibility of cellulitis unless some septic virus has been introduced into the vagina, and been absorbed through some abrasion or fissure in the mucous membrane of the vagina, cervix, or uterus. Certainly such indefinite causes as catching cold, exposure to chill, strains, and the like, are more and more regarded with suspicion; and attention is concentrated on the possibility of the introduction of micro-organisms with its septic consequences.

As regards the production of pelvic peritonitis, the point of most interest is to consider how frequently the disease is consequent on a pre-existing salpingitis. In 1893 Dr. Cullingworth published his researches into this question. Under the heading of "Pelvic Inflammation usually a Peritonitis originating in Salpingitis," he says: "The usual state of things disclosed on opening the abdomen in these cases is as follows:—

"The contents of the pelvis are generally concealed from view by the great omentum, which has been drawn down so as to cover them anteriorly, and has contracted adhesions to the peritoneum as it becomes reflected on to the anterior abdominal wall, as well as to the uterus and other pelvic viscera. Along with this screen, as it were, of omentum, it is not unusual to find coils of adherent small intestine. On separating and drawing aside the screen, one side, or it may be the whole of the posterior part of the true pelvis, is seen to be occupied by what seems to be an indistinguishable mass of matted viscera. The uterus itself is sometimes implicated in the mass, but in other cases its upper part at least is free. Tracing the Fallopian tube outwards from the uterine corner on the side of the disease, it is often found to be normal in size for the first half inch or so, and then to become involved in the adherent mass. This mass, on being separated and brought into view, is invariably found to consist of the uterine appendages more or less altered by inflammation. There is always salpingitis, and the inflamed and thickened tube commonly enfolds the ovary, which is frequently normal."

With regard to the tubes the first point to be noted is that the evidences of peritoneal inflammation are always most marked in the neighbourhood of the fimbriated end; this shows clearly that the pelvic peritonitis has originated by direct extension from the mouth of the inflamed tube, or by the escape of morbid secretions therefrom. Where the secretion from the inflamed tube is chiefly mucous in character, with only a slight intermixture of pus corpuscles, the intensity of the inflam-

mation round the abdominal ostium is shown by the extreme density of the adhesions at that spot and nothing more. Where the secretion, on the other hand, is wholly purulent, one of two things is found to have happened according to whether the fimbriated extremity remains patulous or has become closed. In the former case an intraperitoneal abscess is found, encysted among adhesions, and fed by the purulent discharge issuing from the open mouth of the suppurating tube; in the latter case the pus by its accumulation distends the occluded tube and forms a pyosalpinx. Mr. Alban Doran, in his address before the East Anglian Branch of the British Medical Association in 1893, shows that tuberculous disease commencing in the ovaries and tubes may spread outward and involve the peritoneum, setting up tuberculous pelvic peritonitis. In one case under my own care this was very well shown. On opening the abdomen of a young woman the left ovary and tube were found matted together, and studded with small masses of tuberculous material: the peritoneum as a whole was healthy; but in the immediate neighbourhood of the diseased tube and ovary it was infected, and showed similar foci of tuberculous disease, — in other words, a localised pelvic peritonitis had been set up. It is clear, then, that in a large number of cases the peritonitis is due to some mischief originating in the ovary or tube; but neither clinical nor post-mortem evidence has yet brought us to believe that the disease is always secondary to some pre-existing morbid condition of the uterine appendages.

A form of pelvic peritonitis has been described by Matthews Duncan and others under the name of "encysted serous perimetritis." The peculiar feature is that one or several collections of serous or sero-purulent fluid are found pent up among coils of intestines. The collection may occupy the pouch of Douglas, and press the floor of the pouch so forcibly downwards that the perineum is bulged. In many cases of pelvic peritonitis small collections of serous fluid are found pent up by adhesions between the coils of intestines; but the disease is seldom specially described as serous perimetritis unless the amount of fluid pent up be very extensive. Before leaving this subject attention must be called to the extension of our knowledge regarding pelvic abscess; from what has been already noted, it is clear that collections of pus in the pelvis are by no means always due, as had been supposed, to suppuration of the pelvic connective tissue. Operative surgery has done much to increase our pathological knowledge in this respect: and we now know that many so-called pelvic abscesses are really suppurating dermoid ovarian cysts adherent low in the pelvis, or perhaps tubes filled with pus; or they may be suppurating hæmatoceles, or extra-uterine gestation sacs. This thought brings us to the subject of *treatment* in cases of pelvic inflammation.

With a more exact knowledge of the morbid anatomy and clinical history of these cases of pelvic inflammation our treatment has undergone considerable modifications; and to a large extent active surgical interference has taken the place of a treatment purely medical and pallia-

tive. Indeed, as has been already pointed out, there has been a marked tendency to resort to the use of the knife in an undue percentage of cases; and often, too, in an early stage of the disease before time and observation have shown us what the natural powers of repair are capable of doing. The case is different when the presence of pus can be demonstrated with a fair amount of certainty; for, as an eminent surgeon has well said, a collection of pus calls for the same treatment, whether it occur in the mammary gland or in the pelvis, and opening of the abscess with evacuation of the pus is urgently demanded in either case.

**Disorders of Menstruation.**—The division of these disorders into three groups, namely, amenorrhœa, menorrhagia, and dysmenorrhœa, is a very old one and a very excellent one. In the last fifty years our knowledge of menstruation and its variations has undergone considerable development, not only through the revelation of new facts, but yet more by the exclusion of much that was purely imaginary and false. Several points of considerable discussion and doubt may be considered as finally settled. Thus that menstrual blood does not coagulate is known now to depend on a certain admixture of mucoid secretion from the cervix and uterus. Provided that the menstrual blood be not in excess, and, secondly, that a certain proportion of healthy mucus be secreted, we may be sure that the blood will remain fluid: but if an excess of blood be poured out from the uterine wall, and the mucus be therefore relatively deficient in amount; or if the mucus secreted be morbid in quality or positively deficient in amount, we are certain to find that the menstrual blood does clot. The coagulation which occurs in cases of bleeding submucous fibroids, or again in certain forms of endometritis, illustrates this point.

Another point which has received considerable attention concerns the histology and alterations of the uterine mucous membrane during menstruation. Study of the infantile uterus by Williams and others has shown that to speak of the layer of tissue superficial to the muscular fibres as the mucous membrane is not correct; for the human foetal uterus shows a distinct submucous layer just beneath the peritoneum, so that the whole of the tissue is internal to this mucous membrane. Nearly the whole of the muscular thickness of the human uterus is therefore “*muscularis mucosæ*,” and the apparent absence of a submucous coat is thus accounted for.

Another interesting question, which has been discussed lately, and on which much light has been thrown, is that of the rhythmical contractions of the uterus which occur during menstruation. Viewing menstruation as a miniature labour, one would expect that rhythmical contractions, akin to the recurring pains of parturition, would be set up at the menstrual epoch; and some years ago Braxton Hicks and others stated their belief that these contractions occur. Clear evidence of the fact is afforded by the behaviour of a uterus which contains a fibroid polypus; for with the onset of the catamenia the internal os is dilated, the cervical canal becomes patulous, and the external os is enlarged, so that the



finger can be introduced and the tumour felt. As the menstrual period passes the canal closes down again, and the internal os becomes closed. Again, if the cervical canal be tested by the passage of graduated bougies before and during the first few days of menstruation, the same opening of the cervical canal by the force of the uterine contractions can be observed. Sir John Williams has stated that the uterus contracts during menstruation, because the cavity after menstruation is smaller than it would be if the mucous membrane were gone without uterine contractions. The importance of the recognition of this fact will be seen when we come to study the causation of pain in connection with menstruation. In speaking of the changes which occur in the mucous membrane of the uterus at and about the menstrual epoch, it cannot be said that our knowledge has made much advance; there are many opinions on the subject, but little definite knowledge. Modern research has made one point fairly certain, namely, that the whole of the mucous membrane of the uterus is not shed every month; but rather that certain changes of a hypertrophic and fatty degeneration occur which lead to the exfoliation of the superficial part of this membrane. The papers bearing on this subject by Kündrat and Engelmann, Leopold, Williams, Wyder, and others, are too well known to call for farther comment.

*Amenorrhœa.* — No great advance has been made in our knowledge or treatment of amenorrhœa. In cases of imperforate hymen common sense has taught us that repeated aspirations are quite unnecessary, and that free incision of the hymen under antiseptic precautions, followed by rapid evacuation of the retained menstrual fluid, is a safe and scientific mode of treatment. If the opening made in the hymeneal membrane be free and patulous, there is little risk of fluid regurgitating down the Fallopian tubes, even though these latter be somewhat dilated. Under modern antiseptic precautions one never sees the rapidly fatal instances of septic peritonitis which used every now and again to terminate these cases. In the production of healthy menstruation, it is recognised that a healthy anatomical tract from the ovary to the hymen, a healthy condition of the blood, and a sound state of the nervous system are required; so in considering the causation of amenorrhœa (if we exclude pregnancy, lactation, delayed onset, and the menopause), it is clear that all cases must come under one of these headings.

In his lecture on sterility, Matthews Duncan drew attention to an interesting condition of what he termed "one-child sterility." In these cases a healthy but delicate young woman, usually of the upper classes, marries and begets one child, and after this confinement menstruation never returns, the uterus passes into a senile state, and the woman's reproductive life is practically over. Here the absence of the menstrual function depends on a premature exhaustion of the genital system, and on an early exhaustion of the ovary with its Graafian follicle system.

*Menorrhagia.* — Improved methods of dilatation, and the safety which

comes from the use of antiseptics, have done much to enlighten us on the causation and treatment of uterine hæmorrhage. Thus twenty years ago comparatively nothing was known of the existence and frequency of fungous degeneration of the endometrium; whereas now the use of the curette and digital exploration of the uterine cavity have shown us its frequency in cases of endometritis and fibroid tumour. Of late years the pathological changes taking place in fibroid tumours have been worked out; their methods of cure by natural processes have been clearly laid down, and many points in their treatment have been carefully studied. Reference has already been made to the so-called Apostoli treatment; and whatever the measure of its failure in the cure of fibromyoma, there can be no doubt that in the menorrhagia depending on the presence of a submucous fibroid, this method is a useful addition to our remedies.

Attention has been paid in late years to the influence of an obstructed circulation in the production of uterine hæmorrhage. Thus the late Dr. Wiltshire pointed out the effects of the early stages of hepatic cirrhosis, consequent upon the abuse of alcohol, in keeping up uterine blood loss; here the effect of an impeded portal circulation in preventing easy escape of blood from the uterine circulation is well demonstrated, for by cutting off the supply of alcohol, and exhibiting remedies which act favourably on the portal circulation, the menorrhagia can soon be controlled.

Again, in the case of an overloaded right heart, due to valvular or to pulmonary disease, another mode of production of menorrhagia has been shown; for by the use of means calculated to assist the heart's action the uterine disorder is materially relieved and finally cured. In the knowledge, moreover, of such drugs as hamamelis and the hydrastis *Canadensis*, we have made valuable additions to our store of uterine styptics.

*Dysmenorrhœa*. — It is a cause for regret that we have made so little advance in our knowledge of this common disorder; still in some respects we may claim to have gained a more exact and scientific acquaintance with the phenomena of painful menstruation. Dr. Champneys has endeavoured to limit the use of the word pain as applied to dysmenorrhœa, and has suggested that it is only correctly used when the suffering is clearly due to the genital organs, and falls within the genital sphere. Pain due to the pelvic organs is limited above by a line level with the iliac crests in front and behind, and by the level of the knees below; by this definition various neuralgias, which are often present during the menstrual epoch, are excluded. Tyler Smith and other authorities have compared the act of menstruation to a miniature pregnancy; and I myself, following out this simile, have shown that in a large proportion of cases the pain of dysmenorrhœa is due to some morbid condition at the os internum, and that the pain really depends on dilatation of the internal os by uterine contractions under morbid conditions.

Reference has already been made to the fact, that uterine contractions are present during menstruation, and that their effect in dilating the cervical canal is capable of clinical proof.

One form of dysmenorrhœa, distinguished by the exfoliation of a membrane every month, has received special attention from gynæcologists; indeed, the literature of the subject is so extensive, that were its value equalled by its bulk, our knowledge of the subject would indeed be complete. Much difference of opinion has been expressed on the etiology and pathology of these membranes; but the researches of Wyder and others seem to point to inflammation as their cause. The thickness of the membrane, and the depth of the mucous membrane exfoliated, vary greatly; and the microscopical examination shows a great variety of pathological conditions: all these conditions, however, are "endometritic." Wyder has remarked upon the presence of certain large oval cells, which have a length of from 0.012 to 0.02 mm., and nuclei, whose diameter is 0.006; or these cells, he says, may be two or three times as large. These large cells, he believes, are found only in the decidua of pregnancy, either intra or extra-uterine; and they serve, therefore, to distinguish real membranous dysmenorrhœa from early abortions.

It has been pointed out that it is necessary to distinguish the true membrane of membranous dysmenorrhœa from those consisting of fibrin or blood-clot, coagulated mucus, casts of the vagina or the bladder, foreign bodies, or products of conception. It has been shown by many writers that mucosa membranes may be passed for some time without the presence of any pain; and pain may be a marked symptom later. Thus it is suggested that, apart from some special sensitiveness of the canal of the uterus, pain need not result from the separation and passage of the membrane. How unsatisfactory is our treatment of membranous dysmenorrhœa may be inferred from a remark which Champneys makes use of in his Harveian Lectures. "The treatment of membranous dysmenorrhœa certainly is a most unhappy problem: not even pregnancy going to full time cures it."

There is another pathological condition in which gynæcology has made marked progress during the last fifty years, namely, *inversio uteri*. Until the year 1858, cases of inversion of the uterus after labour were only cured when the patient came under observation shortly after parturition; and in too many cases amputation of the inverted organ was considered the only available resource. About this date Tyler Smith in England, and White in America, recorded cases of slow reduction by taxis and elastic pressure. Of late years cures have been so numerous, even in cases which have come under treatment several years after the accident had happened, that the various instances are hardly thought worthy of record. The method of reduction which is in favour at present consists in the use of Aveling's repositor. The latter instrument was in no sense invented by Dr. Aveling, for Von Siebold employed a repositor which consisted of a curved stem surmounted by a fine sponge, the whole being held in position by a T bandage. Most of these earlier instruments, however, having only one curve on their stem, were liable to slip; whereas in Aveling's repositor there is a double curve (both sacral and perineal), pressure is transmitted in the curve of the pelvic

axis, and slipping is thus rendered less probable. Of the many other plans devised for procuring slow reduction of a chronically inverted uterus, few have stood the test of time; and year by year the Aveling repositer becomes increasingly popular in the cure of these difficult and dangerous cases. In a few cases the accident does not follow labour, but depends on the presence of a fibroid or polypus growing from the fundus uteri; it is in these latter cases that vaginal amputation of the mass, without any attempt at reduction, is indicated.

In the short space available it has been impossible to trace at all adequately, or to do justice to much which may be reckoned as development of our science and practice; but enough has been reviewed to show that in every department of gynæcology—in pathology, in bacteriology, in anatomy, clinical medicine, and surgery—marked progress has been made; and if at times advance has been retarded by over-zealous enthusiasts, still even to them we are perhaps indebted for the finger-posts which point out the roads on which we should not travel. It is clear that much of our increased knowledge is due to improved surgery, and to say this is again to declare the debt we owe to Sir Joseph Lister.

Mr. Pearce Gould put the matter very eloquently when, in his recent address on the Evolution of Surgery, he said: "Although science knows nothing of nationality, and we rejoice in additions to our knowledge, and to our powers of combating disease and death, whether it comes to us from a French Pasteur, from a Teuton Koch, from our western cousins on the other side of the broad Atlantic, or from a son of that Eastern Empire now rising above the horizon, we cannot help feeling a special pride in the fact, that the name that shines with an unrivalled splendour on the page of surgical history is that of the Englishman Joseph Lister."

MONTAGU HANDFIELD-JONES.

#### REFERENCES

1. ATLEE. *Ovarian Tumours*.—2. BATTEY. *Gynæcol. Trans.* 1876.—3. HENRY BENNET. *Inflammation of the Uterus*, 1845.—4. BERNUTZ and GOUPIL. *Archiv Gén.* 1857.—5. BILLROTH. *Surgical Pathology*.—6. BOURDON. *Fluctuating Tumour of True Pelvis*, 1841.—7. BURNS. *Midwifery*.—8. CALVI. *Intrapelvic Phlegmonous Abscess*, 1844.—9. CHURCHILL. *Abscess of Uterine Appendages*, 1844.—10. CLARK. *Diseases of Females*.—11. CLAY. *Obstetric Surgery*.—12. CULLINGWORTH. *Brit. Med. Jour.* vol. ii. 1893.—13. DENMAN. *Midwifery*.—14. DOHERTY. *Chronic Inflammation of the Uterine Appendages*, 1843.—15. ALBAN DORAN. Address Brit. Med. Assoc. *Brit. Med. Jour.* Oct. 1893.—16. *Ibid.* *Uterine Surgery*.—17. MATTHEWS DUNCAN. *Lond. Obstet. Soc.* vol. xxvii.—18. *Ibid.* *Parametritis and Perimetritis*.—19. *Ibid.* *Fecundity, Fertility, and Sterility*.—20. HANDFIELD-JONES. *Brit. Med. Jour.* 1893.—21. HART and BARBOUR. *Diseases of Women*.—22. HEGAR and KALTENBACH. *Op. Gyn.*—23. GREAILY HEWITT. *Diseases of Women*.—24. HODGE. *Diseases Peculiar to Women*.—25. KEITH. *Tumours of Abdomen*.—26. KUNDRAT and ENGELMANN. *Stricker's Med. Jahrbuch.* 1875.—27. LEBERT. *Traité des Mal. Cancéreuses*.—28. LEOPOLD. *Arch. für Gynäk.* Band xi. 1877, Band xxi. 1883.—29. LEVER. *Pelvic Abscess*, 1844.—30. NONAT. *Maladies de l'Utérus*.—31. PAGET. *Surgical Pathology*.—32. PRIESTLEY. *B. M. J.* vol. ii. 1895.—33. SIMS. *Uterine Surgery*.—34. STEPHENSON.



*B. M. J.* March 1892.—35. SUTTON, BLAND. *Roy. Med.-Chir. Transact.* 1889.—36. *Ibid.* *Lond. Med. Soc.* 1892.—37. TAIT, LAWSON. *Diseases of Women.*—38. THOMAS. *Diseases of Women.*—39. THORNTON, J. K. "Abdominal Surgery Past and Present." *Lond. Med. Soc. Transact.* 1890.—40. TILT. *Ovarian Inflammation*, 1850.—41. *Ibid.* *Uterine Therapeutics.*—42. VELPEAU. *Operative Surgery.*—43. VIRCHOW. *Cellular Pathology.*—44. SPENCER WELLS. *Abdominal Tumours.*—45. WILLIAMS. *Harveian Lectures*, 1888.—46. *Ibid.* *Obst. Soc. Lond.*—47. WYDER. *Arch. f. Gyn.* Band xiii. 1878.

M. H. -J.

## THE ANATOMY OF THE FEMALE PELVIC ORGANS

A DESCRIPTION of the anatomy of the genital organs, for gynæcological purposes, should have its own topographical basis; that is, it should be described in relation to the bony pelvis.

I shall therefore arrange this subject under the following heads:—

- I. *The main points in the anatomy of the adult female bony pelvis and of the pelvic floor filling in the pelvic outlet.*
- II. *The anatomy of part of the outer aspect of the floor—that is, of the vulva or external genitals.*
- III. *The anatomy of the organs and tissues in the substance of the pelvic floor—that is, of the vagina, urethra, and bladder; rectum and anus; connective tissue, blood-vessels, lymphatics, and nerves.*
- IV. *The anatomy of the organs on the upper aspect of the pelvic floor—that is, of the uterus, Fallopian tubes, broad ligaments, and ovaries; the pelvic peritoneum.*
- V. *The position of the organs: their dissection and structural anatomy.*
- VI. *The surgical anatomy.*
- VII. *The development of the organs.*

This convenient method of considering our subject is open to some objections. It might be argued, for instance, that the anus and urethra could be considered in other divisions than those in which I have placed them. The present arrangement, however, will be found suitable for our purpose.

**I. The main points in the anatomy of the Female Bony Pelvis and of the Pelvic Floor filling in the outlet.**—The brim of the pelvis (Fig. 1) has, as its boundaries, from left to right, the promontory, left sacro-iliac joint, left ilio-pectineal eminence, symphysis pubis, right ilio-pectineal eminence, right sacro-iliac joint, and thus back to the promontory.

The part of the pelvis above the brim is termed the "false" pelvis; that below the brim is spoken of as the "true" pelvis. It is in the true pelvis and in relation to the outlet that the unimpregnated female genital organs are placed.

If the bony pelvis be regarded in sagittal mesial section (Fig. 2), we can see the conjugate; the cavity of the true pelvis, with its inlet,



cavity, and outlet; the inclination of the conjugate to the horizon (average of  $60^{\circ}$ ), as well as the outline of the pelvic floor. What of the

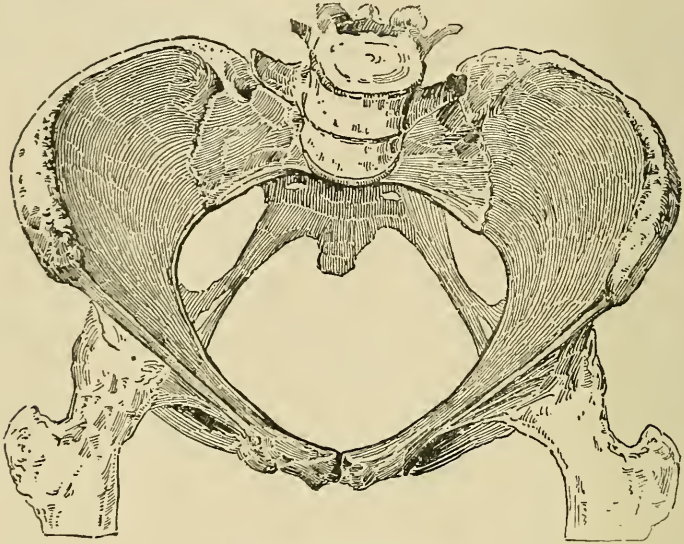

FIG. 1. — Brim of bony pelvis.

pelvic floor projects beyond the outlet-conjugate is termed the pelvic floor projection, and averages, at its utmost, about 3.2 cm.

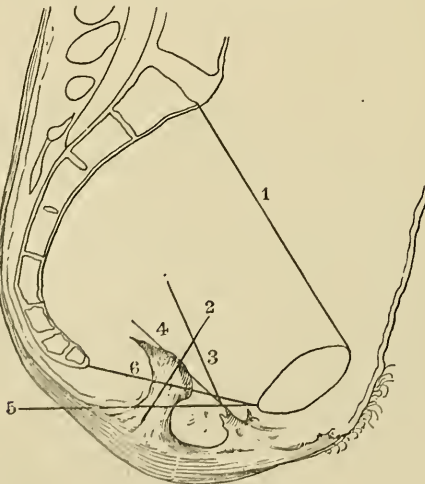

FIG. 2. — Diagram of bony pelvis and of pelvic floor. 1, Conjugate; 2, anal axis; 3, 4, vaginal and urethral axes; 5, horizontal line; 6, outlet-conjugate.

On the outer aspect of the pelvic floor lie the external genitals, and these in the upright posture have a direction nearly parallel to the horizon.

In the substance of the pelvic floor lie the vagina and urethra, parallel to the conjugate, and about 2½ to 3 inches below its level; the anus with

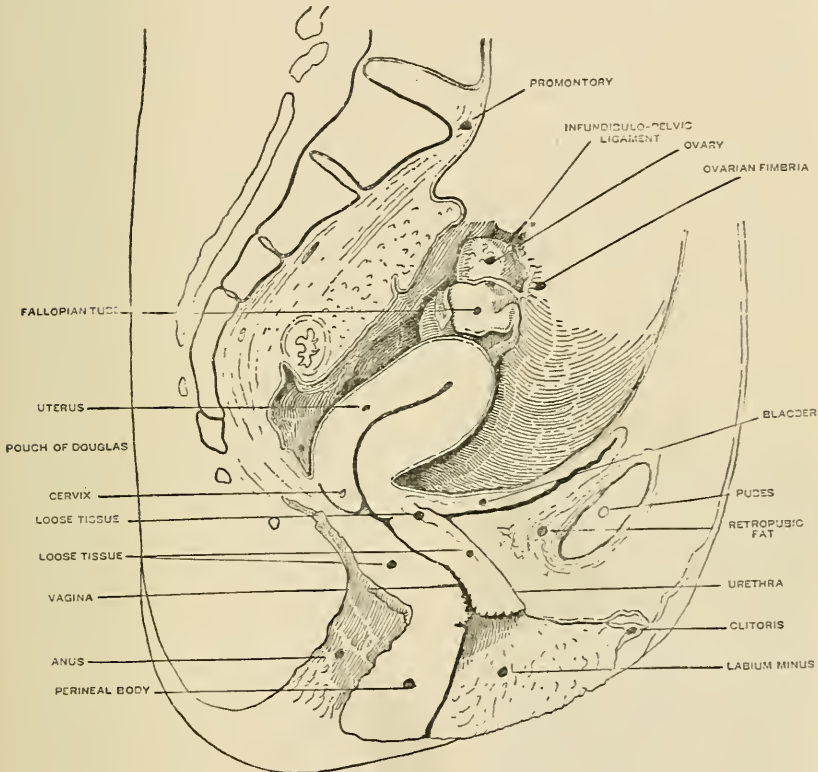

FIG. 3. — Sagittal mesial section of female pelvic floor. The ovary is larger than normal, and the tube relations not quite normal.

its long axis at right angles to these; and resting on the upper surface, the peritoneum and the uterus with its appendages (Fig. 3). Dr. Herman gives the following table of clinical measurements:—

Projection of pelvic floor	.	.	.	3.2 cm.
Coccyx to anus	.	.	.	4.5 cm.
Fourchette to pubic arch (nullipare)	.	.	.	2.19 cm.

II. The anatomy of the External Genitals—that is, of part of the outer aspect of the pelvic floor.—The external genitals lie on a surface extending from the front of the symphysis pubis downwards and back-

wards between the thighs, their posterior boundary, the fourchette, being about  $1-1\frac{1}{2}$  inch in front of the anus. They comprise the following structures; namely, the labia majora, labia minora, fourchette, clitoris and prepuce, vestibule, urethral orifice, hymen, fossa navicularis.

The general arrangement of these parts is seen in Figs. 2 and 4.

It must be noted that in order to see these parts in the living woman their mutual relations are necessarily disturbed. It is therefore of importance to note that, in the undisturbed condition, the labia majora and minora, being in contact by their inner surfaces, conceal the deeper structures, the minora only projecting slightly beyond the majora; that probably the lateral halves of the vestibule are in apposition; that the lateral edges of the fourchette touch, forming a long U, as seen in Fig. 4; and that the lateral edges of the hymen are also in contact.

The *labia majora* are two folds of skin, united above over the pubes in the mons veneris, which pass downwards and backwards between the thighs, gradually thinning off at a point  $1\frac{1}{2}$  inch in front of the anus. Short crisp hair covers their outer aspect, and microscopically we find sweat glands, hair follicles, and the usual constituents of a skin structure.

The *labia minora* are also formed of skin of a thin, fine quality; they lie obliquely on the inner aspect of the upper two-thirds of the labia majora, and by the bifurcation of their upper ends form the prepuce of the clitoris and its so-called suspensory ligament.

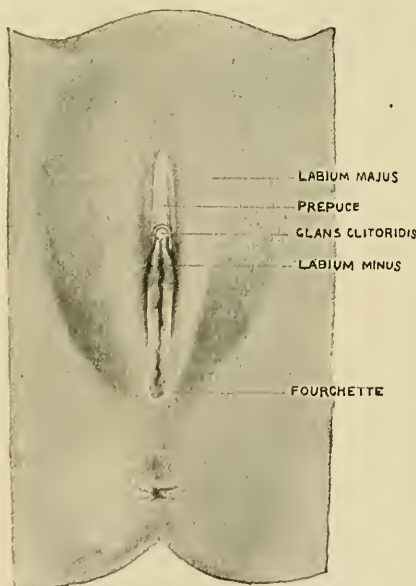

FIG. 4. — Virgin external genitalia with the labia majora separated.

The *vestibule* is a triangular surface of smooth mucous membrane covered with several layers of epithelium, lying between the labia minora, and having the hymen at its base; the urethral orifice is in the middle of the base line immediately above the hymen. In the middle line, in the virgin, is a grooved ridge which represents the corpus spongiosum of the male — Pozzi's male vestibular band.

The posterior ends of the labia minora form a narrow U-shaped loop — the *fourchette*; if these margins be separated we see the fossa navicularis as a shallow fossa, artificially made by the examination, and bounded by the inner aspects of the fourchette and outer and lower portions of the

hymen. Between the fourchette and base of the vestibule lies the

*hymen*, the anatomical entrance to the vagina. It consists of a thin fold of mucous membrane, perforated, so that when viewed undisturbed, its opening forms a vertical slit with its edges in contact. According to Dr. Cullingworth, the hymen is a longitudinal fold of mucous membrane with its edge directed forwards, and divided along about three-fourths of its length by a slit which extends nearer its upper than its lower extremity. The alterations in it induced by coitus and labour belong to obstetrics.

The *anal* opening lies about  $1\frac{1}{2}$  inch posterior to the fourchette, and between the two is the skin over the base of the perineal body (Fig. 4).

The glans of the clitoris covered by its prepuce lies at the apex of the vestibule.

**III. The anatomy of the organs and tissues in the substance of the pelvic floor—that is, of the Vagina, Urethra, Bladder, Rectum, and Anus, Connective Tissue, Blood-Vessels, Lymphatics, and Nerves.**—The *vagina* is a transverse slit in the pelvic floor, extending from the hymen to the fornices, where it passes on to the outer aspect of the vaginal portion of the cervix uteri at the base of the latter; the demarcation between them being recognisable to the naked eye.

The vagina lies parallel to the conjugate, and consists of two apposed walls, anterior and posterior. Each wall is broader above than below, and is therefore somewhat triangular in shape. The mucous membrane lining it is thrown into many transverse shallow folds—the rugæ of the vagina. At the lower end of the posterior wall is one short vertical fold, the posterior column of the vagina; while there are usually two at the corresponding portion of the anterior wall—the anterior columns of the vagina. They are said to represent the remains of the septa between the two ducts of Müller, from part of which the vagina is formed (Fig. 3).

Between the vaginal portions of the cervix and the reflexions of the vaginal walls lie the fornices of the vagina—anterior, lateral, and posterior. The anterior is the guide to the loose tissue between the bladder and the cervix; the lateral lie at the inner aspects of the bases of the broad ligaments, and form a guide to the uterine artery and ureter; while the posterior is separated from the peritoneum of the pouch of Douglas by about  $\frac{1}{3}$  inch of tissue. The walls of the fornices are in contact.

On sagittal mesial section (Fig. 3) the anterior wall,  $2\frac{1}{2}$  inches long, is seen to be straight; the posterior wall,  $3\frac{1}{2}$  inches long, bends forward at its upper part.

On transverse section the vagina is crescentic at its upper part, H-shaped lower down, and vertical at the hymen.

Microscopically the hymen has multiple epithelium on its outer and inner aspects, the latter being thicker.

The vagina is lined on its free surface by many layers of squamous epithelium; deeper down near the papillæ the epithelium is more oval in shape. This epithelium lies on papillæ of connective tissue, with elastic



tissue and unstriped muscular fibre. Outside this lie two layers of unstriped muscular fibre, an outer (circular) and inner (longitudinal). Only a few glands are present in the vagina, which has a structure quite homologous to skin.

It is of great importance to note that loose connective tissue separates the anterior rectal wall and the posterior vaginal wall, and lies also between the bladder wall and the anterior vaginal wall. The urethra and anterior vaginal wall are closely incorporated.

The *urethra* forms a slit in the pelvic floor, parallel to the vagina, and is in reality a tonically contracted sphincter  $1\frac{3}{8}$  inch long with the urethral orifice below and the bladder-opening above. It is lined with many layers of epithelium, squamous below, and like that of the bladder above.

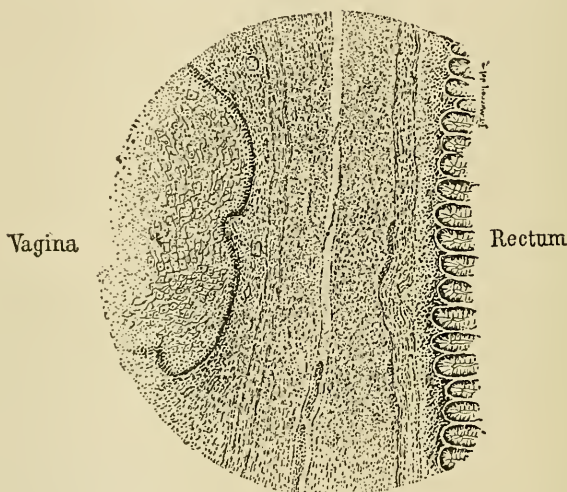

FIG. 5. — Rectal and vaginal mucous membrane.

It is well provided with elastic tissue and muscle; for there are not only circular and longitudinal unstriped fibres, but the same arrangement of striped muscle also. Finally, we should keep in mind that at the meatus mucous glands are present as well as villous tufts. Skene's tubules lie at the lower end of the floor of the urethra, are two in number, about  $\frac{3}{4}$  in. in length. A very important practical point about the urethra is its dilatability. By means of suitable dilators an amount of dilatation can be obtained sufficient to admit the ordinary index finger. Over-dilatation, however, may cause permanent incontinence.

With the empty bladder the urethra forms a Y, the anterior limb of the Y being the longer. Between the urethra, anterior surface of bladder, and the posterior aspect of the pubes is a space, triangular in shape on section, containing loose tissue and fat—the retro-pubic fat (Fig. 3). The *bladder* is sometimes seen in the cadaver as a thick-walled, appar-



ently contracted organ, with its anterior and posterior walls in contact. On sagittal mesial section the cavity then forms a slit continuous with the urethra.

The bladder walls consist of mucous membrane lined with multiple and multiform layers of epithelium, and of unstriped muscle in three layers; its fundus alone is covered by peritoneum. The mucous and muscular coats are separated by loose tissue. The empty bladder is a pelvic organ in the non-pregnant woman. It is generally believed that its capacity is greater in women than in men; and, as a matter of fact, many women pass water twice only in the twenty-four hours.

The *ureters*, two in number, run between the kidneys and the bladder. I shall describe their course in the pelvis only. At the pelvic brim each crosses the external iliac artery, and passes down the side wall of the pelvis below the level of the fossa ovarii. Where the vesical and obturator vessels originate, it begins to describe a bow-shaped curve, the middle portion of which is crossed by the uterine artery at the level of the os uteri externum, from which it is about  $\frac{3}{5}$  inch distant. It here lies related to the side of the vagina (Figs. 8 and 19), and then runs between the anterior vaginal wall and posterior bladder wall. It finally runs in the substance of the bladder wall for about 0.6 inch, and opens into the bladder cavity.

If the bladder cavity be laid open we shall see three openings into it; namely, the internal orifice of the bladder in the middle, and a ureteric opening at each side. The latter are about  $1\frac{1}{2}$  inch from the middle line. Between the ureteric ends lies the inter-ureteric ligament.

The *rectum* begins at the pelvic brim, and ends at the anus. We recognise three portions; namely, the first part, provided with a mesorectum, beginning at the left sacro-iliac joint, and ending at the third sacral vertebra; the second part, where the peritoneum gradually passes off from behind towards the front; and the third part lying behind the posterior vaginal wall. It is separated from the posterior vaginal wall by loose tissue. The microscopical structure of the rectum is peritoneum outside; unstriped muscular fibre in two layers — the longitudinal inner, and the circular outer; and a submucous coat with a mucous membrane provided with a muscularis mucosæ. The mucous membrane is provided with abundant Lieberkühlian follicles.

There are two important crescentic folds in the rectum, which form the sphincter tertius; they lie, one on the anterior wall, the other on the posterior. Each is about  $1\frac{1}{2}$  inch from the anus, the posterior being the higher. The fold is formed by a special thickening of the circular muscles.

The *anus* is a closed slit in the pelvic floor with only a slight antero-posterior linear measurement. It measures about an inch in length, and runs parallel to the axis of the pelvic brim; that is, at right angles to the rectal, vaginal, and urethral axes (Fig. 2). It is provided with a strong musculature (Fig. 6); namely, the sphincter externus, and sphincter internus, — the latter in two layers, circular (outer) and longitudinal (Ruedinger).

In front of the anus lies the *perineal body*, its apex being about the level of the internal opening of the anus and external orifice of the urethra. It is a pyramid of elastic tissue and of striped and unstriped muscular fibre. It forms a bracing point, therefore, for much of the musculature of the pelvic floor; namely, for sphincter ani, transversus perinei, bulbo-cavernosus, and levator ani (Figs. 3, 7, 8, and 9).

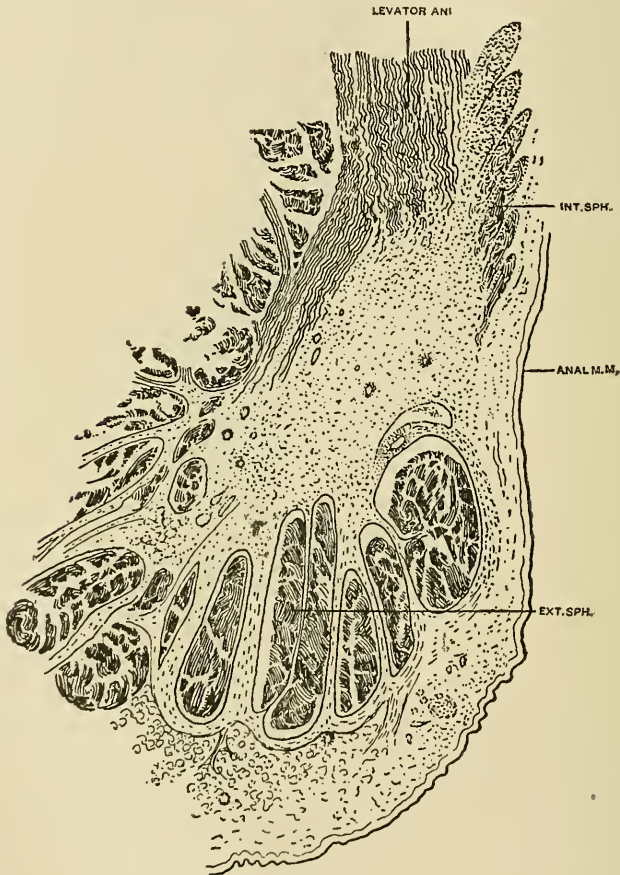

FIG. 6. — Sphincter ani in full-time fetus.

The *connective tissue* of the female pelvis is very abundant and of great importance. It packs all the interstices between the main organs, and is of great pathological interest, as in it run the lymphatics, blood-vessels, and nerves. Although the pelvic connective tissue is practically continuous, and passes up into the iliac fossæ and abdominal cavity, it is convenient to recognise it as being present in the following situations:—

(a) Round the cervix uteri: this is the parametric tissue proper of Virchow. (b) Between the broad ligaments. (c) Between the posterior bladder wall and cervix uteri. (d) Between the vagina and the anterior rectal wall. (e) Between the bladder and the pubes. (f) In the ischio-rectal fossa and below the peritoneum.

By some anatomists the term parametric tissue is made equivalent to pelvic connective tissue.

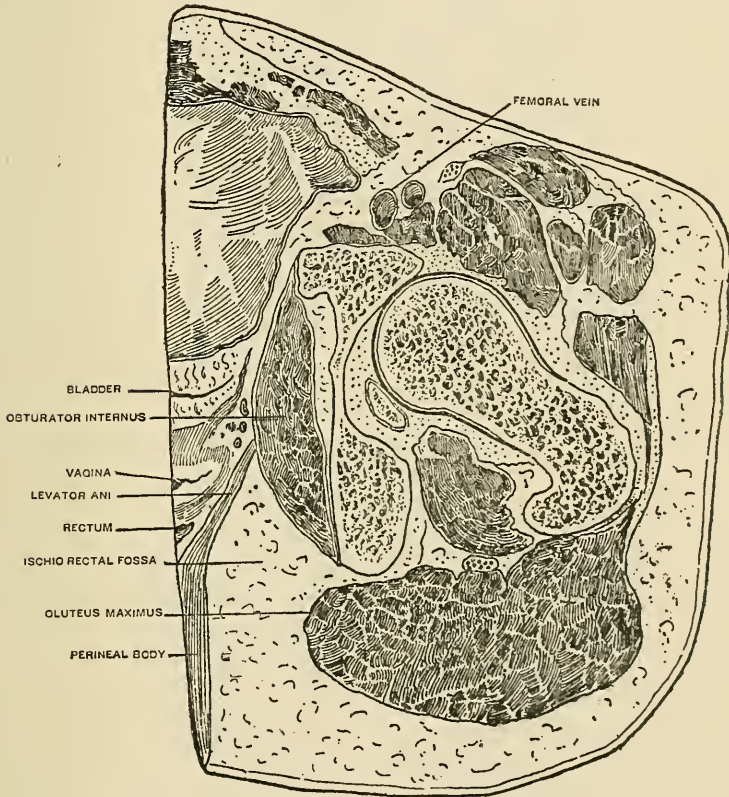

FIG. 7. — Axial transverse section of right half of female pelvic floor. (Seen from behind.)

We have also in the pelvic floor an arrangement of sheet fascia—the pelvic fascia of the anatomist; the main parts of which can be seen in the diagrams of frozen sections (Figs. 7, 8, and 9).

The *blood-vessels* of the pelvis consist of arteries and veins.

The arterial supply of the pelvis is derived from the *ovarian* and *uterine arteries*.

The *ovarian artery* is a branch of the aorta, and passes along the upper border of the broad ligament below the level of the Fallopian tube.

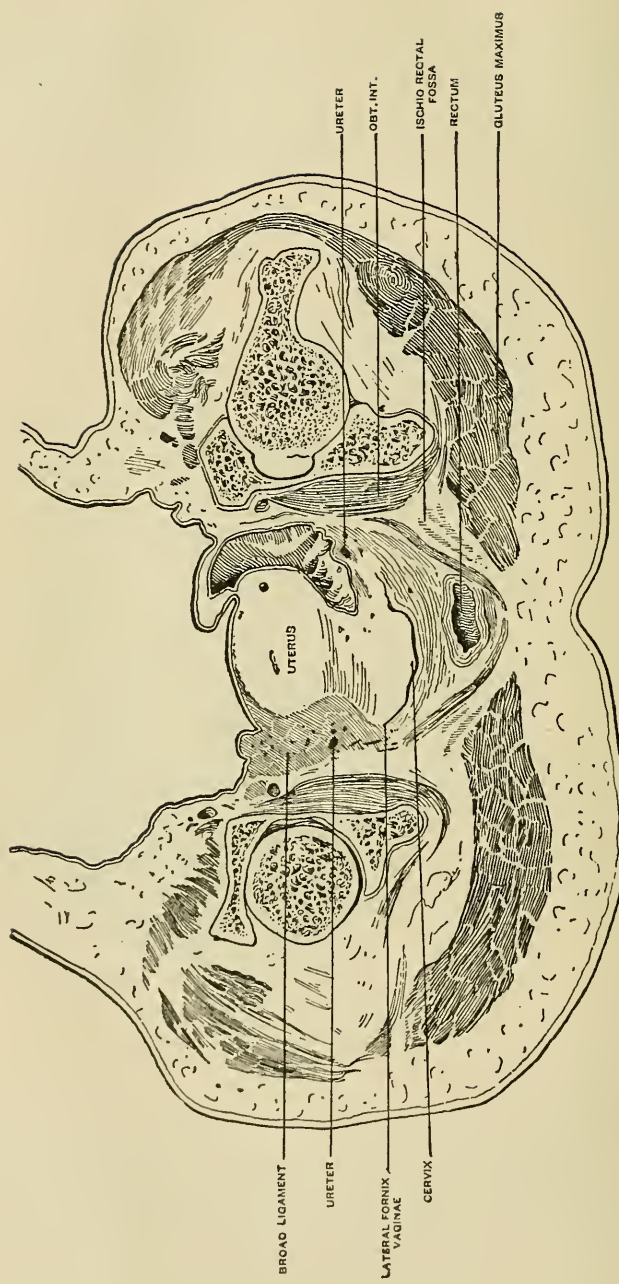

Fig. 8. — Axial transverse section of female pelvic floor.



It gives branches to the tube, ovary, and round ligament; and then at the junction of tube and uterus passes tortuously down the sides of the uterus to join the uterine artery. From the arch thus formed at the side of the uterus branches pass at right angles into the uterine substance.

The *uterine artery* is a branch of the anterior division of the inter-

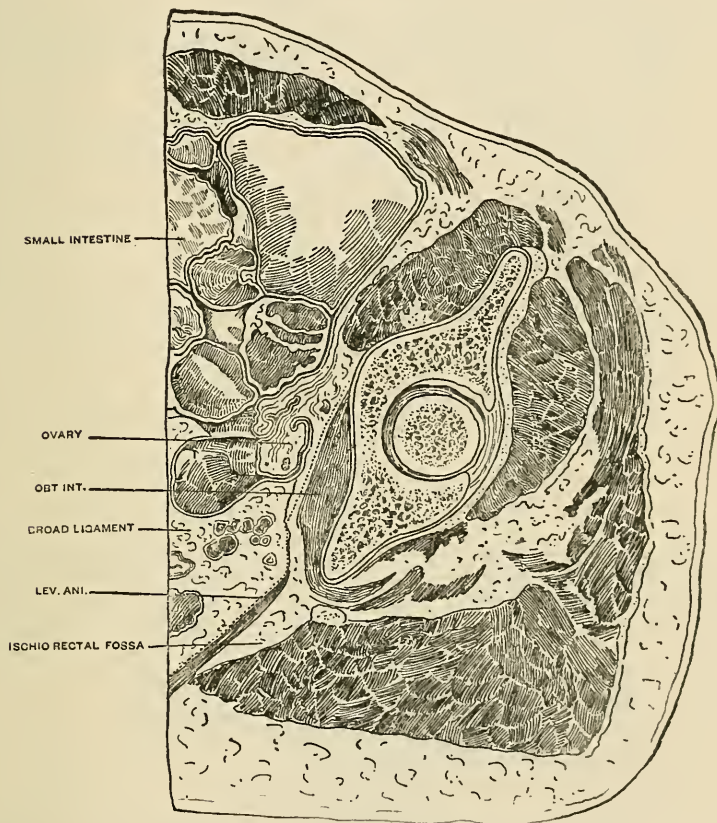
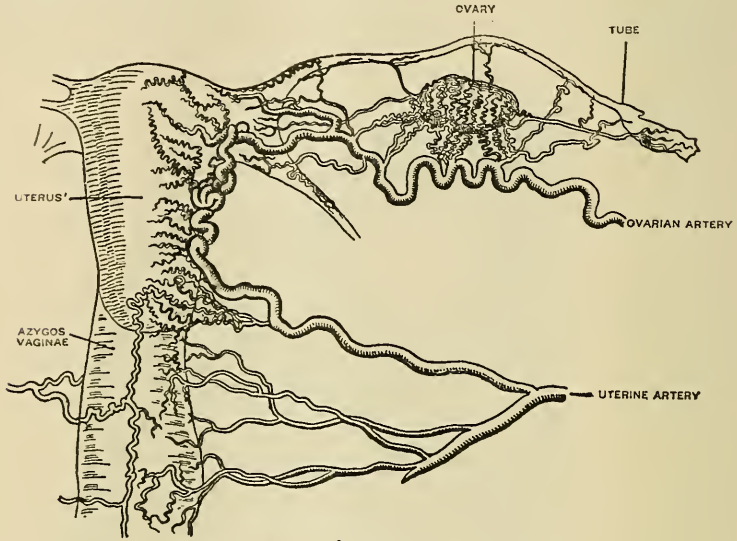

FIG. 9. — Axial coronal section of right half of female pelvis. (Seen from behind; dotted line = fascia.)

nal iliac. It passes downwards and inwards towards the cervix uteri, giving a well-marked branch to the cervix—the circular artery; but sometimes several smaller branches take its place. The relation of the uterine artery to the ureter must be kept in mind. The uterine artery also gives branches to the vagina; and these, with branches from the circular artery, form the azygos artery of the vagina. The *pubic artery*, a branch of the same anterior division of the internal iliac, is a well-marked vessel at the outer boundary of the ischio-rectal fossa; and



from it we get the superficial and transverse perineal arteries, the artery to the bulb, corpus spongiosum, and clitoris, and the inferior hæmorrhoidal artery (Figs. 10 and 21).



*Blood supply of uterus (Hyrtl)*

FIG. 10.

The venous supply of the pelvis consists of many anastomosing plexuses. There are thus vesical, hæmorrhoidal, labial, vaginal, uterine,

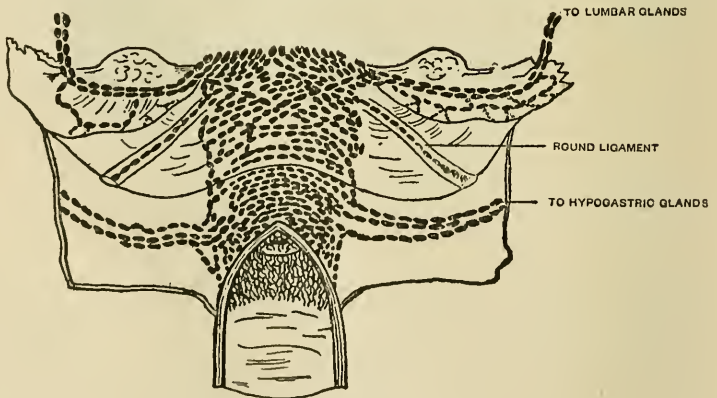

FIG. 11. — Lymphatics of uterus. (Poirier.)

ovarian, and pampiniform plexuses. The vesical, vaginal, hæmorrhoidal, and pudic veins open into the internal iliac, and this passes to the infe-

rior vena cava. An important point is that the superior hæmorrhoidal vein passes to the portal system, and we thus get an anatomical explanation of the menorrhagia of drunken women. The pelvic veins are unprovided with valves. The uterine plexus opens into the ovarian veins; the right ovarian vein passing to the inferior vena cava, where it is provided with a valve; the left to the renal vein.

The *lymphatics* (Figs. 11 and 12) of the pelvis begin in connective tissue spaces, form plexuses, and are so arranged that those from definite areas pour into definite groups of glands. Thus the lymphatics of the

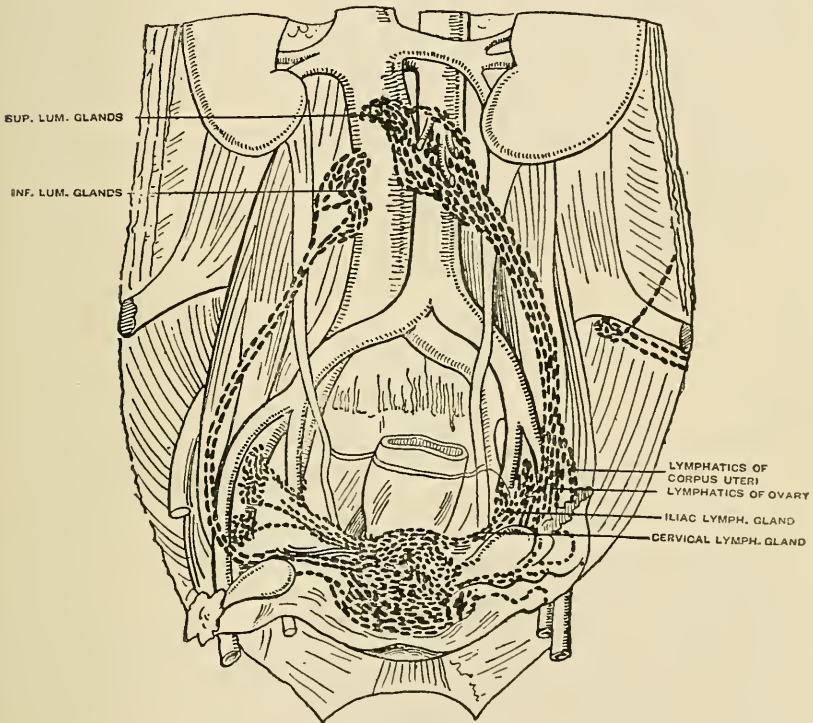

FIG. 12.—Lymphatics of uterus and pelvis. (Poirier.)

external genitals and lower fourth of the vagina pour into the oblique inguinal glands; those of the upper three-fourths of the vagina and cervix uteri into the iliac glands. The lymphatics of the body of the uterus pass along the broad ligaments, and, accompanied by those from the ovary and Fallopian tube, reach the lumbar glands. The lymphatics of the round ligaments open into the inguinal glands, and a gland lying on the obturator membrane also establishes a communication between the pelvic connective tissue and the inguinal glands. The rectal lymphatics open into the sacral glands; those of the bladder pass to the iliac glands.

These facts are of great pathological importance. In malignant disease of the vulva and lower fourth of the vagina, the oblique inguinal glands are affected; but in cancer higher up, the pelvic and lumbar glands are first infiltrated. Through the lymphatics of the round ligament, and especially through the obturator gland, we may have, though rarely, late infection of the inguinal glands in uterine cancer. I have now several times seen the inguinal glands enlarged in pelvic sarcoma, and in one instance I found the obturator gland distinctly enlarged.

The abundant lymphatic supply of the pelvis explains the inflammatory attacks arising from sepsis and gonorrhœa, and abundant evidence of their importance will come up afterwards. Here we can only emphasise the great importance of antiseptics in operative work, and the

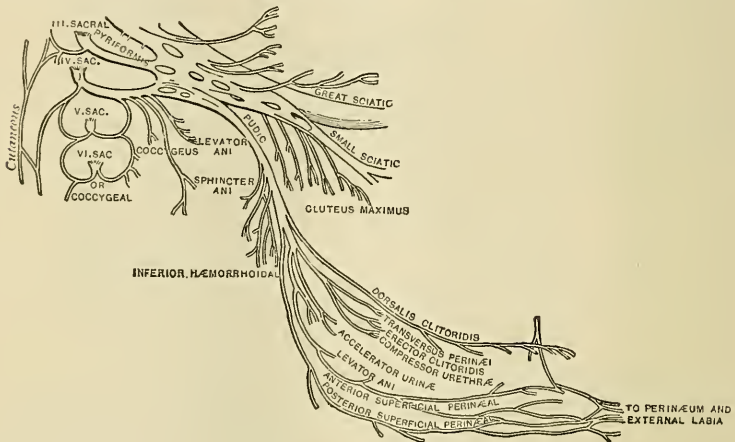

FIG. 13.—Nerve diagram. (Flower.)

avoidance of all minor manipulations with the sound as a means of diagnosis in the consulting-room.

The *nerves* of the pelvis are spinal and sympathetic. The levator and sphincter are innervated by the inferior hæmorrhoidal branch of the pudic, and by the fourth and fifth sacral and coccygeal nerves; the coccygeal nerves and fourth and fifth sacral also supply the coccygeus. Branches of the pudic nerve pass to the muscles of the perineum and clitoris.

The sympathetic is arranged in many plexuses. The hypogastric plexus between the common iliac arteries gives branches which, with those from lumbar and sacral ganglia and sacral nerves, make up the inferior hypogastric plexuses lying on each side of the vagina. Branches from them pass to the vagina, uterus, Fallopian tubes, and ovaries.

Special end bulbs are found in the clitoris and labia minora. In the vagina the nerves end in the epithelium. In the uterus, nerve plexuses and nerve cells are present in the muscular coat, and the nerve-endings can be traced to the glands and epithelium.

In the tube the nerves are arranged in two concentric plexuses, ending in the epithelium and in the nerve cells of the submucosa. In the ovary the nerve-endings have been traced to the Graafian follicles and cells of the membrana granulosa.

Pain is so common a gynæcological symptom that it is remarkable that gynæcologists have not brought more precision into their descriptions of it. In a recent paper in *Brain*, Dr. Head has attempted to give greater accuracy to the definition of these sympathetic painful areas; he states that the area for ovarian pain is "limited above by a line running horizontally from the top of the first lumbar spine to the umbilicus; below by a line running from the third lumbar spine to midway between the pubes and umbilicus, but having a little downward tag near the anterior superior iliac spine." For the body of the uterus and Fallopian tubes the area is bounded above by the preceding one; and below by a line running from a little below the top of the sacrum to the symphysis, but having a dip down over the buttock, and another over the front of the thigh. For the cervix uteri the painful area is over the lower part of the sacrum. For the ovary, therefore, it is formed by the sensory fibres from the tenth dorsal nerve root; for the body of the uterus and Fallopian tubes by the sensory fibres of the eleventh and twelfth dorsal nerve roots; and for the cervix by the sensory fibres of the third and fourth sacral roots.

#### IV. The anatomy of the organs on the upper aspect of the pelvic floor

—that is, of the Uterus, Fallopian Tubes, Broad Ligaments, and Ovaries; the Pelvic Peritoneum. (Figs. 14 and 15.) *The Uterus.*—If the uterus be separated from its appendages, it will appear as a pear-shaped body with a constriction—the isthmus—slightly below its middle, dividing it into two great parts, the body and cervix. At its inferior extremity is the os uteri externum; at the upper right and left angles lie the openings of the Fallopian tubes. Its anterior surface is more flat than the posterior, and only the upper half of the former is covered by the peritoneum. If a vertical mesial section be made, we can then see that the uterus has a cavity or slit, that its walls are about half an inch thick, and that the cavity is lined by mucous membrane  $\frac{1}{25}$  inch (1 mm.) thick. In a section through the cavity, dividing the uterus into anterior and posterior portions, we can see the shape and relations of its cavity more clearly displayed. The cervical canal is somewhat spindle-shaped, and the so-called uterine cavity consists of anterior and posterior triangular surfaces which normally, and in the unimpregnated condition, are in apposition. The os

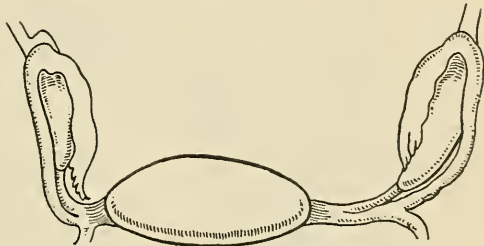

FIG. 14. — Relations of uterus and ovaries viewed through brim. (Hlis.)



uteri externum is the lower boundary of the cervical canal; the upper boundary is less definite, but for practical purposes we may place it opposite the isthmus. The os uteri internum is the lower opening of the uterine cavity proper, while to the right and left above are the internal

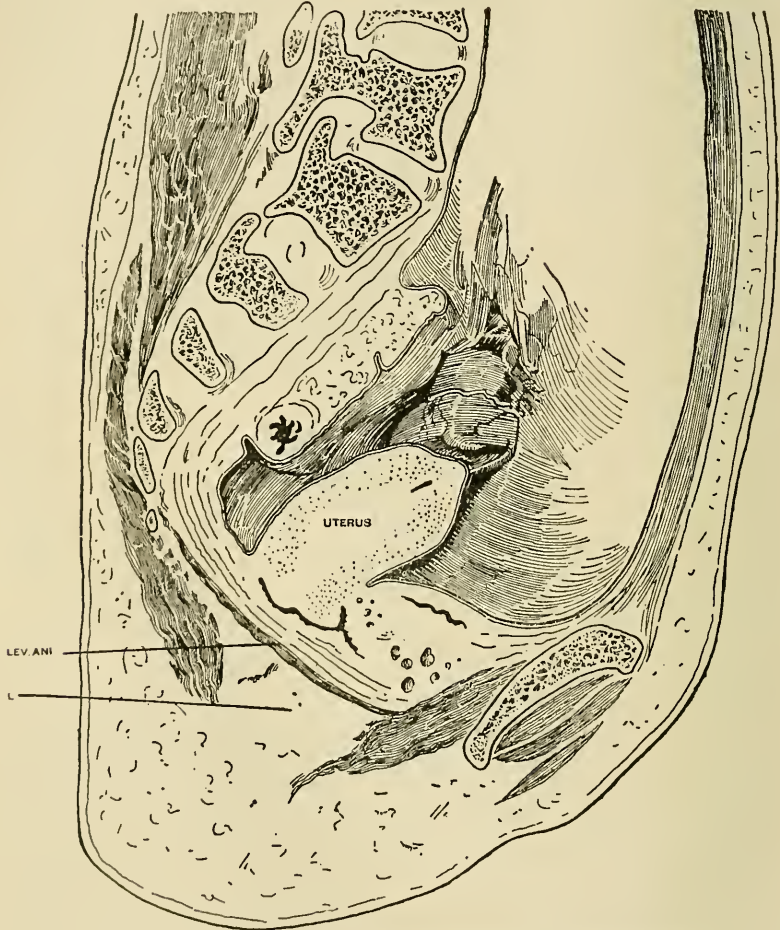

FIG. 15. — Sagittal lateral section of female pelvis. L points to ischio-rectal fossa.

openings of the Fallopian tubes. These three points; namely, the os uteri internum and the Fallopian tube openings — map out the normal surface from which menstruation takes place, and where normal pregnancy occurs. It is difficult to divide the unimpregnated uterus accurately into its various parts. If we take the anterior wall of the uterus we may consider it as made up of three portions: firstly, the cervix, where the bladder is attached, and with the os uteri internum as its upper boundary —



the average measurement of this is an inch: secondly, the lower uterine segment, which is rudimentary, and is bounded below by the os uterine

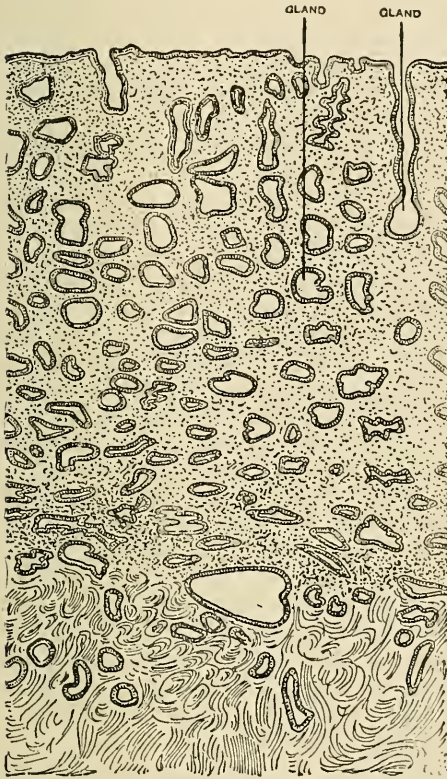

FIG. 16.—Uterine mucous membrane showing relation of glands and stroma.

internum, and above by the firm attachment of the peritoneum—it measures about half an inch, and has not yet been accurately mapped out: thirdly, the body of the uterus proper, which begins where the peritoneum is firmly attached, and extends up to the fundus.

The cervix has been divided by some into a vaginal, middle, and supravaginal portion; and this division is of importance in relation to cervical hypertrophies. The vaginal portion is the symmetrical, unattached part of the cervix (Fig. 17); the middle portion is attached to the bladder in front, but is free behind; and the supravaginal portion is attached to the bladder in front and to the vagina behind.

*Structure of the Uterus.*—The outer aspect of the uterus is covered by peritoneum, except where the bladder is attached. Its wall is half an inch thick, and made up of unstriped muscular fibre and connective tissue. The mucous membrane of the uterus is  $\frac{1}{2}$  of an inch thick and merits special description. In the cervical canal the mucous membrane has a peculiar arrangement visible to the naked eye—the well-known arbor vite. This consists of a vertical ridge with lateral ones slanting upwards and outwards. The cervical mucous membrane consists of columnar epithelium, ciliated and narrow, with the nucleus deep in the cell. Many glands of a racemose type are present, and penetrate deeply into the connective tissue. In the substance of

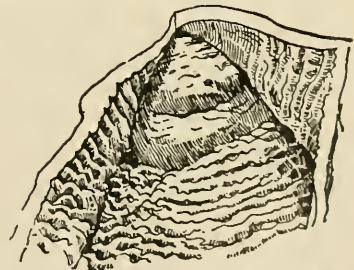

FIG. 17.—Cervix and upper part of vagina showing rugae.

the cervix are dense connective tissue and unstriped muscular fibre. The vaginal portion of the cervix is covered with many layers of squamous epithelium continuous with and similar to that of the vagina. The mucous membrane of the uterine cavity proper is  $\frac{1}{2}$  of an inch thick, and of a grayish red colour: it consists of a surface covering of columnar epithelium and an embryonic connective tissue. Numerous so-called "glands" open on its surface, and ramify and intersect in all directions down to the muscular coat. There is no submucous connective tissue. The "glands" are lined with columnar epithelium of the same nature as the surface epithelium, and continuous with it. So far as my observation goes, the epithelium does not rest on a *membrana propria*. There has been much discussion as to the nature of these so-called glands: it is best on the whole to regard them not as specially glandular, but as mere pits of epithelium, honey-combing the mucous membrane. The mucous membrane is really a lymphatic tissue, reticulated with epithelial diverticula whose function in some points we understand. During menstruation there is a superficial denudation of the mucous membrane; and it is from the epithelial pits and the connective tissue between them that regeneration takes place. During pregnancy also, we have, persisting close to the muscular coat, the funduses of these pits in the form of the well-known spongy layer. This arrangement permits not only of the separation of the placenta and membranes during the third stage of labour, but also gives again epithelium and connective tissue for the development of a new mucous membrane during the puerperium. The connective tissue itself consists of elongated cells with nuclei, and branching small round cells anastomosing with one another. Leucocytes when present are to be considered pathological; and the same is the case in regard to unstriped muscle in the stroma. According to Leopold, the bundles of connective tissue are surrounded by endothelial cells, which thus form lymph spaces.

The *Fallopian tubes* are two in number, and pass out from the right and left upper angles of the uterus towards the side of the pelvis in a way to be described more fully afterwards. Each is about 10 cm. in length, and lies below the upper margin of the broad ligament. They are covered by the peritoneum for about five-sixths of their periphery, the remaining and lower sixth resting on the connective tissue between the layers of the broad ligaments. The following divisions are recognised: a portion piercing the wall of the uterus, the interstitial part; a straight portion, or isthmus; a curved portion, the ampulla; and, finally, the fimbriated end, with the special ovarian fimbria. The tube consists of a peritoneal covering; a muscular coat in two layers, circular inner and longitudinal outer; and a remarkably folded mucous membrane. The mucous membrane lining the tube is continuous with that of the uterus, and is thrown into many longitudinal folds which pass out into the fimbriated end. In the fimbriated end can be seen the ostium abdominale or outer opening of the tube. One special fimbria, the ovarian fimbria, joins the ovary and tube. We must note here the remarkable fact that the

genital tract of woman communicates by this ostium directly with the peritoneal cavity (Figs. 14 and 15).

The mucous membrane of the Fallopian tube consists of columnar epithelium and connective tissue. The foldings of the mucous membrane are very much less marked in the isthmus, much more so in the ampulla. The question whether these foldings constitute glands is still disputed; but I see no valid reason as yet for considering them as anything more than a honey-comb arrangement of the tubal lining, indicating, so far as we know at present, its close developmental relation to the uterus. The calibre of the isthmus is such as to admit a bristle, while the ampulla will admit the ordinary uterine sound.

The tube in the fœtus has windings in it of a pathological interest. The *hydatid of Morgagni*, derived from the duct of Müller, is attached to the fimbriæ or tube, and has a mucous columnar lining with clear fluid. Muscle and peritoneum make up its head and stalk. It must not be confounded with cysts in the mesosalpinx arising from Wolffian relics.

*Ovaries.*—The ovaries, two in number, lie projecting from the posterior lamina of the broad ligament, and on the side walls of the pelvis. The diameter of each ovary is  $1\frac{1}{3}$  inch by  $\frac{3}{4}$  by  $\frac{3}{8}$  of an inch. The posterior surface looks backwards, the anterior is attached to the broad ligament; their long axis is either perpendicular or somewhat transverse. The part of the ovary joining the broad ligament is named the hilum.

*Structure of the Ovary.*—The ovary is covered on its outer aspect by columnar epithelium, the germ epithelium of Waldeyer, who first indicated its nature and importance in development. At the hilum the germ epithelium is continuous with the squamous epithelium of the broad ligament, the boundary being marked by the well-known white line of Farre. In fresh specimens the ovary has a dull, pearly lustre, the broad ligaments being more grayish.

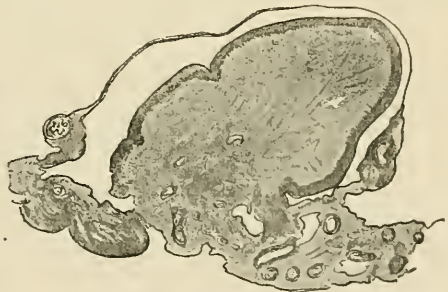

FIG. 18.—Seal's ovary showing cortical and medullary layers, also peritoneal capsule with tube on section.

While Farre drew attention to this line of demarcation, he unfortunately omitted to note the real nature of the covering of the ovary, a mistake readily made if he examined adult ovaries only.

Below the germ epithelium lies the tunica albuginea, a condensed concentric arrangement of connective tissue. On section we see that the rest of the ovary is made up of two portions, a cortical or outer zone, and a medullary or vascular zone continuous with the tissue of the broad ligament. In the cortical portion, and surrounded by connective tissue, we have the remarkable structures known as the Graafian follicles. Each ovary contains a very large number of these follicles, but whether they amount to eighty or ninety thousand, as some authors allege, is not quite



certain. The Graafian follicles near the surface of the ovary are small, the larger ones being deeper; but a few of the largest lie at the periphery. Each Graafian follicle consists of a tunica fibrosa and a tunica propria, the so-called membrana granulosa, lined with columnar cells and containing the liquor folliculi. Usually the membrana granulosa has a projection of cells, the discus proligerus, which contains the ovum proper. The ovum is made up of zona pellucida, yolk, germinal vesicle, and germinal spot (nucleus and nucleolus). The columnar cells immediately surrounding the ovum form the corona radiata. The fresh

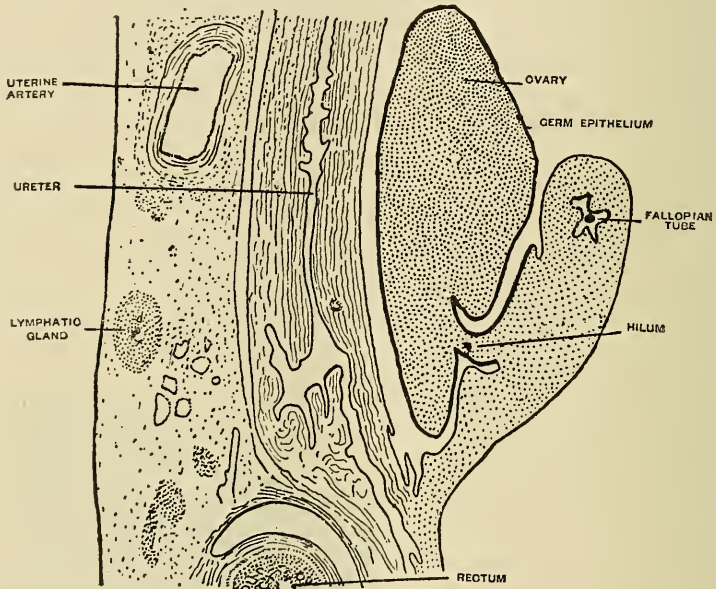

FIG. 19. — Sagittal lateral section of genital organs in  $3\frac{1}{2}$  months' fetus. Note proximity of rectal and broad ligament connective tissue; the relations of ureter, ovary, and uterine artery are the same in the adult.

nucleolus has been noted to have amœboid movements. The ovary lies in a shallow depression of peritoneum, the fossa ovarii. In some of the lower animals, such as the rat and seal, the ovary is surrounded by peritoneal capsule, and thus is shut off from the general peritoneal cavity. It is alleged that the same arrangement may occur in the human female, and be a source of tubo-ovarian cysts (Bland Sutton). The connective tissue consists of round cells, and at the hilum are many blood-vessels.

*Pelvic Peritoneum.* — The upper aspect of the pelvic floor, the uterus, and its appendages are covered by peritoneum, the arrangement of which must now be described.

On sagittal mesial section the arrangement is as follows, from before backwards: — The peritoneum of the anterior abdominal wall is reflected

on the fundus of the bladder a little above the level of the pubes. It then passes on to the anterior surface of the uterus, about the level of the os internum, over the fundus, and down the posterior wall of the uterus, which it covers completely. It dips down on the uppermost half inch of the posterior vaginal wall, and finally becomes reflected upon the sacrum and rectum. The vesico-uterine pouch of peritoneum lies between the bladder and uterine wall. The posterior dip of the peritoneum below the level of the isthmus is known as the pouch of Douglas; it will be more fully described shortly. The vesico-uterine pouch has sometimes been erroneously termed the space of Retzius (Figs. 3 and 7).

The broad ligaments are formed by two folds of peritoneum passing out from the sides of the uterus to the side wall of the pelvis. The anterior fold of the broad ligament is a continuation of the peritoneum on the anterior surface of the uterus. Beneath it lies the well-known round ligament, which passes from the junction of the Fallopian tube and uterus, forwards and outwards to the inguinal canal. These round ligaments contain striped and unstriped muscular fibre, blood-vessels, and nerves. The posterior lamina of the broad ligament is in the same way a prolongation outwards and backwards of the peritoneum on the posterior surface of the uterus. It is larger than the anterior lamina, and lies partly on the side wall of the pelvis. Thus the ovary comes to lie both on the posterior aspect of the broad ligament and on the side wall of the pelvis. Between the layers of the broad ligament lie connective tissue, blood-vessels, lymphatics and nerves; the connective tissue passing up into that of the iliac fossa. The so-called ovarian ligament joins the lower end of the ovary and the angle between tube and uterus; the uterine muscle passes into it. The Fallopian tube occupies the greater part of the top of the broad ligament. The infundibulo-pelvic ligament of the ovary is that part of the top of the broad ligament not occupied by Fallopian tube, and to a certain extent it suspends the ovary. The paro-varium also lies between the layers of the broad ligament near the ampulla, and consists of a single longitudinal tube with several vertical ones. It represents the remains of the Wolffian duct and body, and will be more particularly alluded to afterwards. The utero-sacral folds are two ridges of peritoneum enclosing muscular fibre and connective tissue; they pass one from each side of the isthmus uteri, outwards and backwards towards the second and third sacral vertebræ. The pouch of Douglas can now be more accurately defined. Its upper lateral limits are the utero-sacral folds; in front the isthmus forms the anterior boundary, behind is the peritoneum covering the sacrum and rectum. The fact that so many pathological products are found in the pouch of Douglas, or its neighbourhood, is to be explained not only by its affording an actual pouch for lodgment, but by the near presence of the ovary; and above all by the fact that the openings of the Fallopian tubes lie posterior to the broad ligament. Between the utero-sacral fold and the broad ligament lie the lateral pouches of Douglas, while on each side of the bladder there is a para-vesical pouch.



V. The Position of the Organs: their dissection and structural anatomy. — The position of the organs is best ascertained and described in an adult pelvis which has been hardened and the superjacent intestine

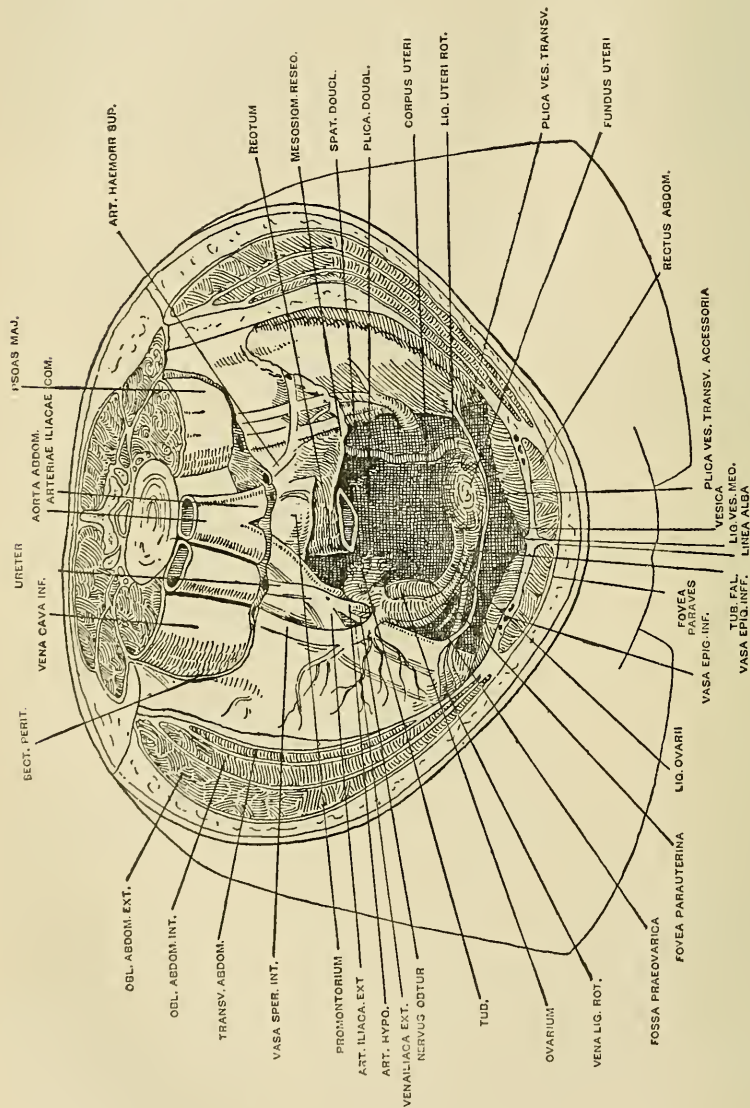

Fig. 20. — Pelvis and contents from above. (Waldeyer.)

carefully removed. One of the best of these drawings has been recently published by Waldeyer (Fig. 20). The uterus lies below the level of the brim, usually to the one side, and is anteverted and anteflexed. Viewed

from above, therefore, one can only see its fundus and posterior surface. The anterior surface touches the bladder, so that the vesico-uterine pouch is usually empty. The normal uterus is perfectly mobile, and its shape and normal relation to the vagina is a developmental one. Those who advocate ventro-fixations seem to forget entirely that the uterus is a mobile pelvic organ, and that after such operations it lies for a time in a state of abnormal position and fixation.

The *Fallopian tubes* pass, firstly, out towards the side of the pelvis; they then turn up, and the fimbriated end becomes applied to the posterior aspect of the ovary.

The *ovary* lies on the posterior lamina of the broad ligament, on the side wall of the pelvis, below the level of the brim, and in front of the sacro-iliac joint. The ovary on the side of the pelvis to which the uterus is inclined has its long axis vertical (Fig. 14); the other ovary has its long axis more or less transverse.

The *vagina* runs through the pelvic floor parallel to the conjugate. The part of the rectum in relation to the vagina and to the urethra is also parallel to the conjugate. The long axis of the anus is parallel to the axis of the pelvic brim. The external genitals in the upright posture make a small angle with the horizon.

*Dissection of the Pelvis.* — If a cadaver be placed in the lithotomy posture a dissection may be made over the rectal portion of the perineum, and also of the anterior urethral portion. When in the former case the skin is suitably removed, we come upon the superficial fascia with much fat, and the base of the ischio-rectal fossæ. If the fat, superficial vessels, and nerves be removed from these we then see that each fossa is bounded on the inside by the levator ani, and on the outside by part of the obturator internus. The varying portion of these boundaries is best seen on section (Figs. 7, 8, 9). Between them, the sphincter externus can be dissected out. The pudic artery lies on the inner aspect of the ischial tuberosity. If the skin be now removed from the anterior urethral portion we come first upon the superficial fascia, and then on the deep layer of the superficial fascia. This latter is attached to the pubic arch, its base hooking round the transversi perinei to join the anterior layer of the triangular ligament. On its removal we now see a double triangular arrangement of muscles, one on each side of the middle line. The base of each triangle is formed by the transversus perinei, the outer side by the erector clitoridis, the inner by the bulbo-cavernosus or sphincter vaginae. Below the lower end of the bulbo-cavernosus lies the Bartholinian gland with its duct opening at the sides of the hymen. Higher than the Bartholinian glands, and still below the bulbo-cavernosus, lie the erectile structures known as the bulbi vaginae. The removal of these muscles now exposes the anterior layer of the triangular ligament. This layer having been dissected off, we come upon the terminal branches of the pudic vessels and nerves lying on the posterior layer, and then cut into the retro-pubic fat. The exact relations of the fascia here have not yet, however, been accurately worked out. The triangular

ligament undoubtedly acts as a supporting element to the urethra and vagina, which perforate it; and in the rare cases where a nullipara suffers from prolapsus uteri the edge of the triangular ligament, where it is perforated by the vagina, can be felt like a ring (Fig. 21).

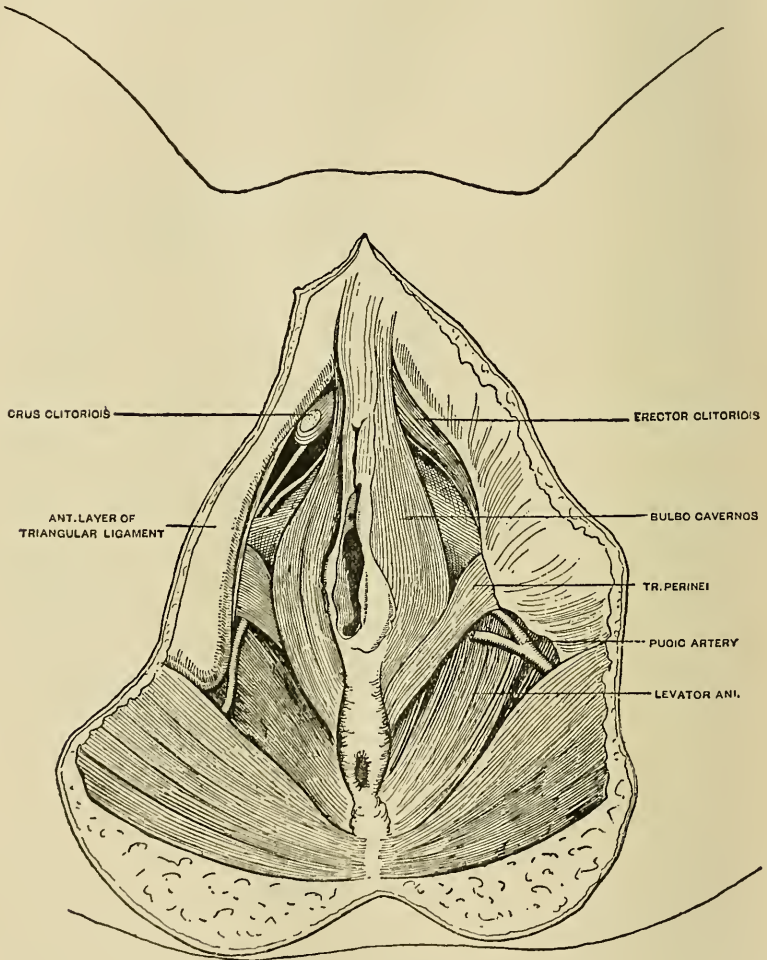

FIG. 21. — Perineal region.

If a dissection be now made from above, and the peritoneum, uterus, and appendages removed, the pelvic diaphragmatic muscles will be exposed. These are the coccygei and the levatores ani; and viewed from above they form a concave muscular arrangement. The levator ani has its origin from the posterior aspect of the pubes, from the white line of fascia,

and the ischial spine. The fibres pass down, almost vertically, to become attached to the vagina, the rectum, its fellow, and the tip of the coccyx.

The coccygeus has its origin from the spine of the ischium and passes to the lower part of the sacrum and front and side of coccyx.

The obturator internus is well seen in the sections (Figs. 7, 8, 9).

*Structural Anatomy.*— In sagittal mesial section the pelvic floor is an unbroken layer. The vagina and urethra do not impair its strength, as they are slits passing through it at right angles to the direction of intra-abdominal pressure. The floor, however, can be divided into two portions,—an anterior pubic mobile segment, and a posterior more fixed or sacral segment. The vagina thus forms a boundary between these two. The pubic segment consists of bladder, urethra, and anterior vaginal wall. Its mobility is due not only to the less firm nature of its tissue, but also to its loose attachment to the pubes.

The sacral segment is firmly attached to the sacrum, and consists of the tissue behind the posterior vaginal wall, which is included in it. In the upright posture the sacral segment is the supporting one, intra-abdominal pressure pressing the pubic segment against it.

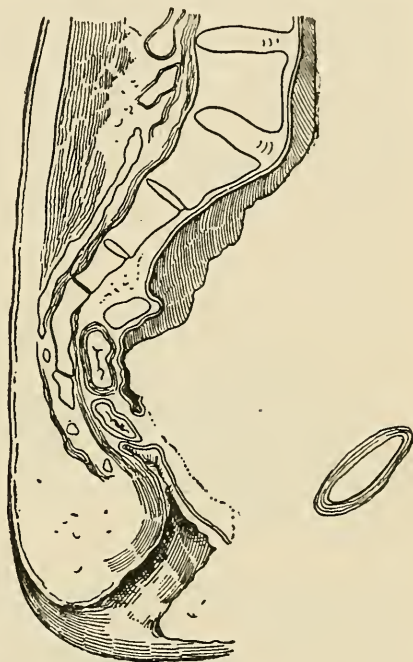

FIG. 22.— Sacral section of pelvic floor.

*Changes in pelvic floor due to posture.*— In the position known as the genu-pectoral the abdominal bulge lessens at the pubes and increases near the diaphragm. The projection of the pelvic floor is also less marked; but the pelvic floor is still unbroken. The following facts are now of great importance:— If the edges of the hymen be separated, air passes in and the vaginal slit becomes a cavity. The uterus if anteverted previously becomes more so, and lies farther from the vaginal orifice. The retroverted unfixed uterus does not become anteverted when a patient assumes the genu-pectoral posture, and air is admitted into the vagina; but the uterus lies farther from the vaginal orifice and becomes more retroverted. These facts as to the dilatation of the vagina by posture give the key to proper specular examination, as was first shown by Marion Sims. The same dilatation of the vagina can be attained in the position known as Sims' semiprone posture, and also in the lithotomy posture, especially if the hips be raised. These postural methods are also



invaluable in rectal and vesical examination. In the same way the rectum can be ballooned, and also, as Kelly has shown, the bladder.<sup>1</sup> In this way, and by simple specula, thorough visual, and, in certain cases, digital examination of the bladder, vagina, and rectum can be made; as will be fully explained in the appropriate section. In examination of bladder cases the genu-pectoral posture is advantageous, as well as in reposition of the gravid retroverted uterus.

**VI. Surgical Anatomy.**—In operative pelvic surgery by the vaginal route the following points must specially be kept in mind:—

i. *The posture of the patient and the mobility of the uterus.*—There is no doubt that the lithotomy posture is the most convenient for all operative work. By means of a broad, short, modified Sims' speculum the vagina becomes dilated in this posture; and then with

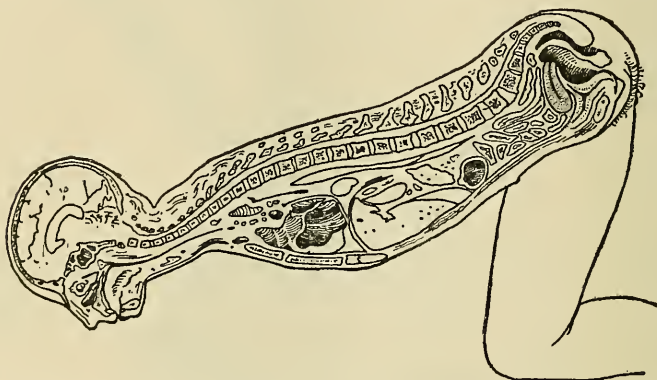

FIG. 23. — Diagram of genu-pectoral posture showing vaginal distension. (Based on frozen section.)

the volsella the uterus can in most instances be safely drawn near the vaginal orifice, and an accessible field of operation thus obtained. By most operators the use of the semiprone posture has been abandoned for the more convenient lithotomy one.

ii. *Blood-supply: Lines of loose connective tissue in the pelvis allowing the separability of the organs.*—In the flap operations on the perineum, now so generally adopted, the loss of blood is trifling. The bleeding is mainly venous, and is readily checked by pressure. In making the usual perineal incision with scissors it is advantageous to have the thighs well flexed on the abdomen, so as to render the parts tense. In suturing, the flexion should be less marked.

The lines of loose tissue in the pelvis are of the greatest importance from an operative point of view. Thus if a transverse incision be made over the base of the perineal body, so as to split it into anterior and posterior parts, the finger can then pass into the loose tissue between the anterior rectal wall and posterior vaginal wall; and these can be easily

<sup>1</sup> Pawlik of Prague claims priority in this.



separated till the peritoneum of the pouch of Douglas is reached. In this way dermoids of the recto-vaginal septum have been enucleated, and also certain forms of deeply burrowing extraperitoneal gestation attacked. This route is one seldom followed, but it is worthy of being kept in mind. The loose union between rectum and vagina allows of posterior colporrhaphy operations. The operator can make a vertical mesial incision on the posterior vaginal wall until the loose tissue is reached; he can then separate laterally, with the handle of his knife, the posterior vaginal wall, remove what seems necessary, and suture. I must also point out that this loose union between anterior rectal and posterior vaginal wall is an important factor in allowing prolapse of the uterus. In the same way the loose tissue between the bladder wall and the upper portion of the anterior vaginal wall allows of anterior colporrhaphy.

In vaginal hysterectomy the operator readily cuts by a transverse incision through the posterior fornix into the pouch of Douglas, as the thickness of tissue here is only  $\frac{1}{3}$  inch. Anteriorly a transverse incision in the vaginal fornix exposes the loose tissue between the bladder and cervix, and the vesico-uterine pouch can soon be opened. Here as a rule little bleeding arises, but it is quite otherwise with the lateral attachments of the cervix; there the tissue is dense and abundantly vascularised by the uterine artery. Before cutting the lateral attachments, therefore, it is imperative for the operator either to ligature or to apply pressure forceps: the anatomy of the ureter must also be kept in mind, as there is less than  $\frac{2}{3}$  inch between it and the cervix uteri. When once the firm lateral attachments of the cervix have been thus separated the uterus can be more thoroughly drawn down, and the broad ligaments secured in the same way as in the case of the lower lateral attachments.

Operations on the upper part of the vulva are usually superficial, as in clipping away irritable skin in pruritus vulvæ. The bleeding is usually insignificant, even if the glans clitoridis be cut off. The operator must beware of cutting below the apex or sides of the pudic arch.

In abdominal surgery the anatomy of the incision in the linea alba needs no remark. In pelvic adhesions the operator must be specially careful in the neighbourhood of the sacro-iliac joint and side of the pelvis owing to the position of the ureter here, and to the proximity of the large iliac vessels.

Recently Dührssen and Martin have recommended in certain cases, instead of abdominal section, incision by way of the loose tissue between the bladder and the uterus.

**VII. Development of the Organs.**—The subject of the development of the female genital organs is too complex to admit of full consideration here, and I shall therefore only take up some points of practical importance. In a human fœtus of about the sixth week an important stage is displayed. This can be well seen in the diagrams obtained in a fœtus carefully prepared in transverse serial section by my former assistant, Dr. Gulland. The fœtus was obtained from a case of extirpation of a six weeks' pregnancy, where cancer of the cervix was present; it was thus

perfectly fresh and in all respects normal. In the diagram of the transverse section of the abdominal cavity are seen the two Wolffian

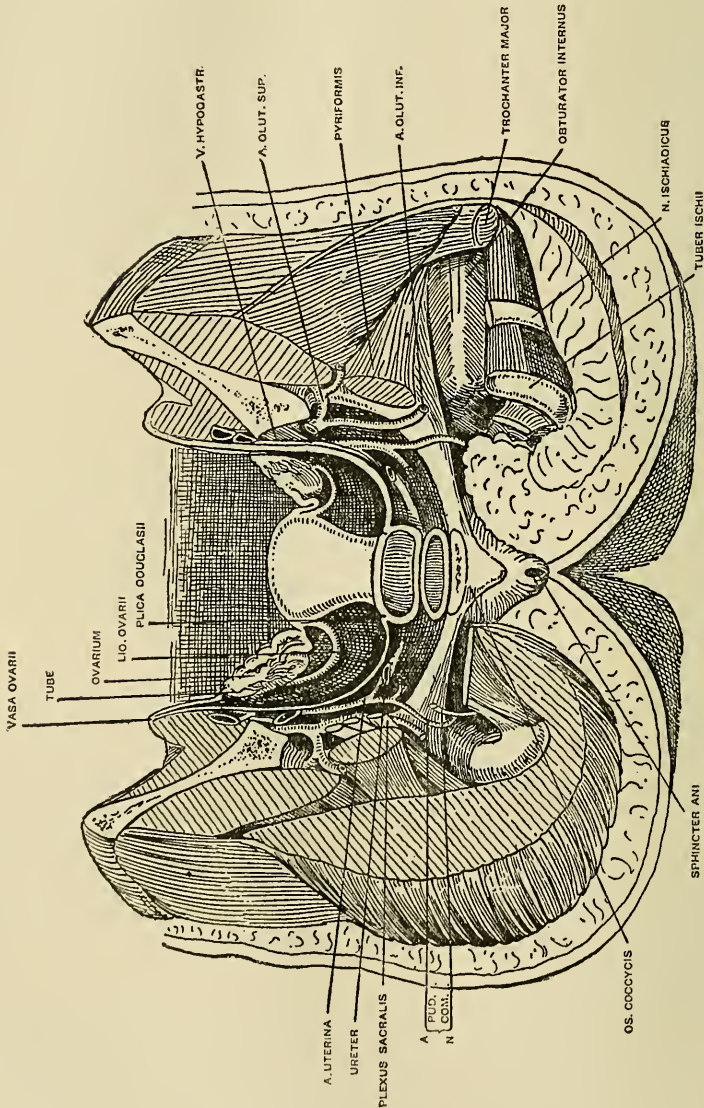

Fig. 24. — Dissection from behind. (Henke.)

bodies, markedly developed (Fig. 25). Lower down (Fig. 26) they have diminished in size, and are represented only by a few tubules; while the ovary, pedunculated and with well-marked germ epithelium covering it,

can be noted (Figs. 26 and 28). The broad ligaments with the duct of Müller can also be seen.

Lower down in the pelvis the genital cord is displayed (Fig. 27);

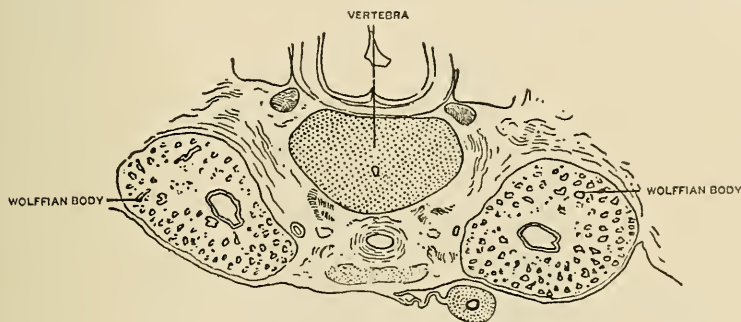

FIG. 25. — T. S. of Wolffian bodies in six weeks' fetus.

and at this stage one can note three canals in it; the centre one being formed by the coalesced ducts of Müller, while each lateral one is the Wolffian duct. This agrees, therefore, with the usual statement that in

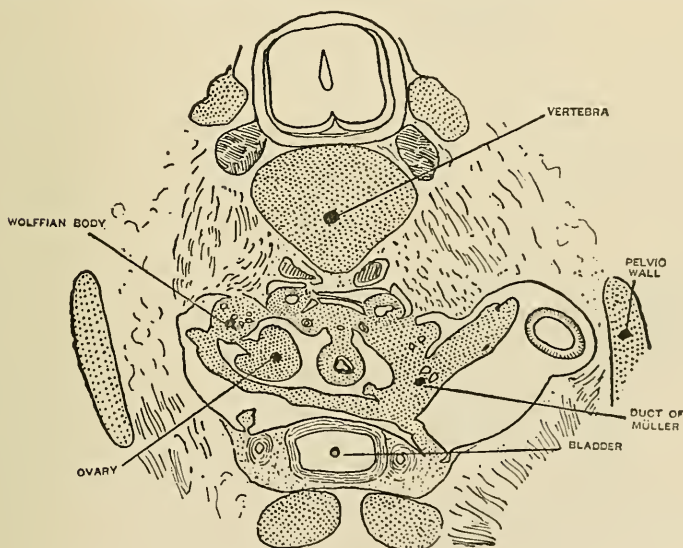

FIG. 26. — T. S. pelvis, six weeks' fetus. Note wide transverse of pelvis.

the early fetus there are two sets of organs — the Wolffian bodies with their ducts, and the ducts of Müller. The former atrophy in the female sex but leave their traces in the broad ligaments, where are normally found the parovarium, or epoophoron (Fig. 28), and also certain additional but

occasional relics in the form of tubules at the hilum, or of a special tube in the broad ligament, uterus, or vagina, rarely continuous in all

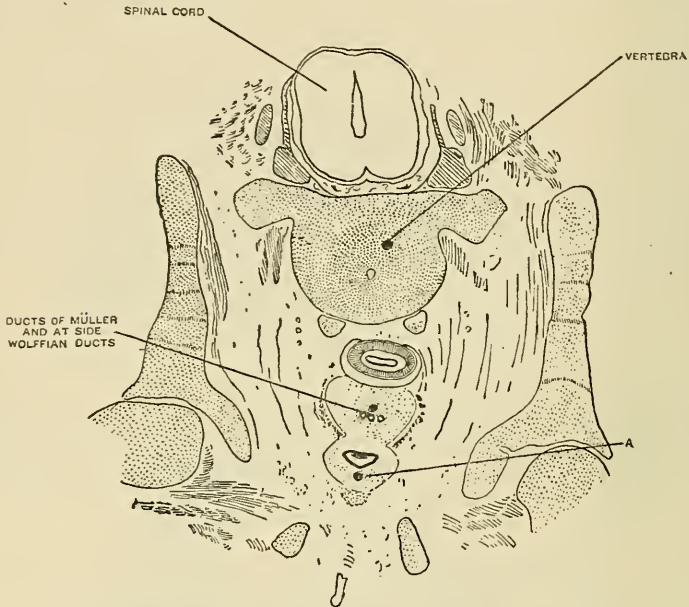

FIG. 27. — T. S. of six weeks' fetus showing genital cord. *a* points to tissue in front of rino-genital sinus. On the posterior wall of the sinus is the eminence where the ducts of Müller end.

of them, known as Gärtner's canal. It represents the Wolffian duct, and may be a source of retention cyst in the localities already named; it is normally present in the cow and sow.

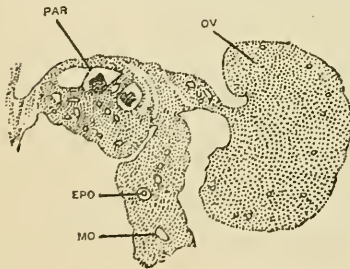

FIG. 23. — Section of ovary and Wolffian body, human embryo, third month. (Nagel.)  
*md*, Duct of Müller, *par*, paroophoron;  
*epo*, epoophoron (that is, parovarium).

The *ovary* develops as an epithelial thickening on the Wolffian body. The outer cells of the ovary form the germ epithelium of Waldeyer, which, by sending prolongations into the substance of the ovary, forms the ova.

The *ducts of Müller* give rise to the Fallopian tubes, uterus, and vagina. They remain separate to form the tubes, and coalesce to form the uterus and vagina. Disturbance in this normal coalescence gives rise to malformations. According to some anatomists, the Wolffian ducts enter into the formation of the vagina, and give rise to the H-shape on transverse section. As the diagram shows, the ducts of Müller forming the vagina at first have a lumen; but by epithelial proliferation from the Wolffian bulbs they become solid. At



the lower part of the vagina there develop about the third and a half month two special oval epithelial proliferations, which break down centrally and thus form the hymen (Fig. 29). These bulbs I have recently found to be developed from the Wolffian ducts, and I have termed them

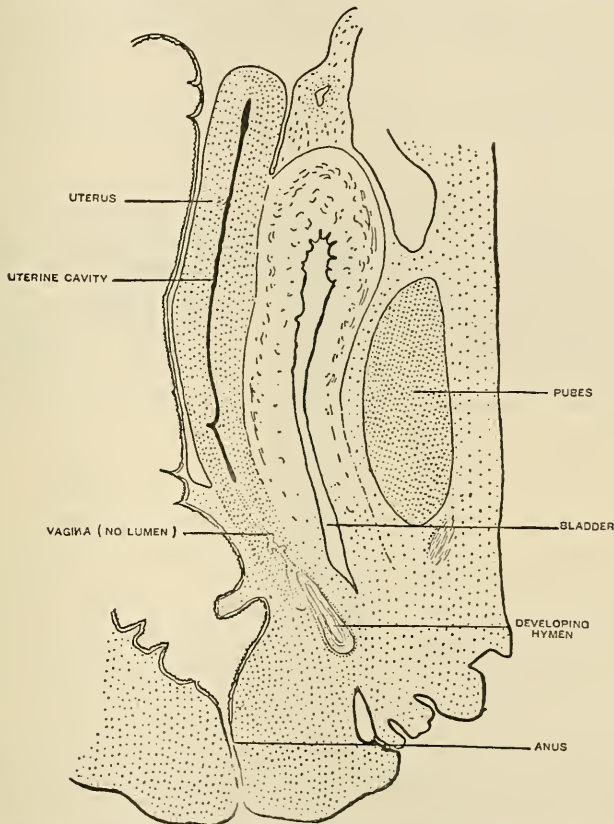

FIG. 29. — L. S. of  $3\frac{1}{2}$  months' fetus to show development of hymen. This shows formation of hymen by development of two bulbs from Wolffian ducts: these join and break down in the centre, and are met by an involution of hypoblast below.

the Wolffian bulbs. This figure also shows the involution of the deeper layers of the vestibule to meet the hymen. About the fourth or fifth month the solid vaginal proliferation flattens out, and then forms a lumen. I believe, however, that it may do so earlier (Figs. 27 and 29).

In the early foetus (fifth to sixth week) a cloaca is present: the Wolffian ducts open into the urino-genital sinus (Fig. 27) up till the third month, when they are closed by the development of the hymen. The subsequent stages are the formation of a septum and the development of the clitoris in front, and labia at the sides.

The relation of the pelvic organs to the germinal layers is of interest.

The uterus, tubes, and ovary are mesoblastic; the adult vagina has its lining derived from the epiblast, the lower involution from the local outer covering, but the lining above the outer aspect of the hymen is furnished, as an examination of my specimens seems to me to demonstrate, through the Wolffian duct. The Wolffian duct is really epiblastic in its origin. The anus is also epiblastic, while the bladder and rectum are hypoblastic. The vestibule is derived from the urino-genital sinus, and is hypoblastic.

The main practical points resulting from this development are as follows:—

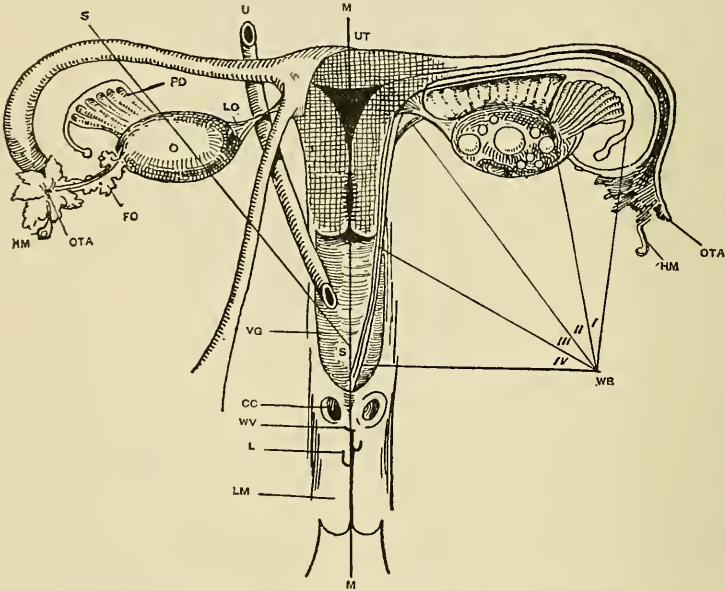

FIG. 30. — Diagram of developing and fully formed genital tract. *Ota*, Ostium tubæ abdominale; *hm*, hydatis Morgagni; *fo*, ovarian fimbria; *o*, ovary; *lo*, ovarian ligament; *po*, parovarium; *lr*, round ligament; *vg*, vagina; *we*, upper wall of vestibule; *cc*, corpus cavernosum clitoridis; *u*, ureter; *l*, labium minus; *lm*, labium majus; *wb*, Wolffian body. On the right side are seen the normal organs, on the left the Wolffian-body relics and duct in addition. (Coblentz.)

1. Normally in the adult woman we find traces of the Wolffian body and duct in the parovarium (Fig. 30). This is the source of the ordinary parovarian tumour.

2. Skene's tubules in the urethra are probably not Wolffian relics, but represent the glands of the male prostate.

3. Abnormal relics of the Wolffian body at the hilum of the ovary, and in the broad ligaments, may give rise to papillomatous developments. Some authors, however, consider the germ epithelium as more probably the source of these when they are present in the ovary.

4. Gärtner's canal may give rise to broad ligament, uterine, and vaginal cysts.

5. Malformations are really due to persistent stages of arrested development.

D. BERRY HART.

#### REFERENCES

The following references do not represent Gynæcological Anatomy, but merely the main sources used in this sketch. Fuller sources are indicated, and should be consulted when necessary.

1. CULLINGWORTH. "A Note on the Anatomy of the Hymen and that of the Posterior Commissure of the Vulva," *Jour. of Anat. and Phys.* vol. xxvii. p. 343.—2. FARRE. "Uterus and its Appendages," *Encyc. of Anat. and Phys.* vol. v. Suppt.—3. FLOWER. *Nerves of the Human Body*. London, 1872.—4. FRANKENHAEUSER. *Die Nerven der Gebaermutter*. Jena, 1867.—5. GAWRONSKY, V. "Ueber Verbreitung und Endigung der Nerven in den weiblichen Genitalien," *Arch. für Gyn.* Bd. xlvii. S. 271.—6. HART. *Atlas of Female Pelvic Anatomy*. Edin. 1884.—7. *Ibid.* *Contributions to the Sectional Anatomy of the Female Pelvis*. Edin. 1885.—8. HEAD. "On Disturbance of Sensation with Special Reference to the Pain of Visceral Disease," *Brain*, 1893.—9. HERMAN. "A Contribution to the Anatomy of the Pelvic Floor," *Trans. Lond. Obst. Soc.* vol. xxxi.—10. HENKE. *Topographische Anatomie des Menschen*. Berlin, 1879.—11. HYRTL. *Die Corrosions Anatomie und ihre Ergebnisse*. Wien, 1873.—12. KLEIN. "Entstehung des Hymen," *Festschrift der Gesellschaft für Geb. und Gyn. in Berlin*. Wien, 1894.—13. MINOT. *Human Embryology*. New York, 1892.—14. SUTTON, J. B. *Surgical Diseases of Ovary*. London and New York.—15. WALDEYER. *Beiträge zur Kenntniss der Lage der weiblichen Beckenorgane*. Bonn, 1892. For a fuller record of literature see Hart's *Atlas and Index Medicus*.

D. B. H.

## MALFORMATIONS OF THE GENITAL ORGANS IN WOMAN

**Introduction.**—The malformations of the female genital organs form a natural and sharply defined group of deformities whose special interest, from the gynæcological standpoint, lies in the effects which they produce upon the menstrual phenomena, and upon the sexual and reproductive life of the woman in whom they exist. These effects vary greatly in importance with the nature, position, and extent of the malformation; and also, doubtless, with the constitution of the patient and her condition as regards marriage. Manifestly the absence of the uterus is a more serious matter than the imperfect development of an ovary or a tube; and malformations which are of grave import in a married woman may exist without inconvenience in a spinster.

It will be convenient to consider, first, the malformations of individual organs, beginning with those of the ovaries, and dealing in turn with the Fallopian tubes, uterus, vagina, and vulva; I shall then discuss the abnormalities which affect more than one of the reproductive organs, including cases of "hermaphroditism."

In studying these genital anomalies, it must not be forgotten that we are concerned with organs which are derived from at least three distinct sets of embryonic structures. As embryology is the true key to the understanding of the nature of malformations, it will be well to state shortly what these organs and structures are.

**DEVELOPMENT OF THE FEMALE GENITAL ORGANS. — I. The Ovaries.**

— In the early, sexually indifferent embryo a development of certain cells of the genital fold or ridge takes place on each side of the vertebral column in the lumbar region. These cells of the germinal epithelium, for that is the name given to the epithelium of the peritoneum in this region, form the genital or sexual glands which develop at a later stage into the ovaries in the female and the testicles in the male. Only a part, however, of the genital gland is thus produced. In the female this part of the ovary contains the ova, and is called the oophoron; the other portion, the paroophoron or tubuliferous portion, has a different origin. In the early embryo there is seen, lying to the outer side of the genital fold, a glandular mass — the mesonephros or Wolffian body, with a duct — the segmental or Wolffian duct. In the male, some of the tubules of the Wolffian body extend into the genital gland, and form the rete testis, others remain as the vasa efferentia, whilst the Wolffian duct becomes the epididymis and vas deferens. In the female the Wolffian body largely atrophies; still, just as in the male, some of its tubules enter into the genital gland, and form the paroophoron, whilst others, along with the Wolffian duct, persist in a rudimentary state as the parovarium or epoophoron, and occasionally as Gärtner's duct.<sup>1</sup> At a later stage in development the sexual glands descend from their primitive position, the testicles passing to the scrotum, and the ovaries to the brim of the true pelvis. Such is the composition and development of the ovary; and the anomalies which may be expected are, therefore, malposition or non-descent of the whole organ, and abnormalities by excess or defect of either or both its constituent parts, oophoron and paroophoron.

2. **The Fallopian Tubes, Uterus, and Vagina** are the representatives of the two Müllerian ducts of the embryo. Lying near the Wolffian body, and on the outer side of the Wolffian duct, the Müllerian duct, which is at first a solid cord, passes downwards to open into the allantoic portion of the cloaca. At a later stage the duct acquires a lumen, and later still it fuses, in its lower portion, with its fellow of the opposite side to form the uterus and vagina, whilst its upper part remains separate as the Fallopian tube. In the male foetus the Müllerian ducts atrophy almost entirely, and are represented only by the uterus masculinus or prostatic vesicle, and possibly by the true hydatid of Morgagni. The anomalies that may be expected in connection with these organs in the female are irregularities in the fusion of the lower parts of the Müllerian ducts, in their mode of termination, their partial or complete absence, and their imperforate condition. As will be seen later, all these malformations (that is, double uterus and vagina, uterus unicornis, atresia and defectus uteri et vaginae, and so forth), and others which are not so easily explained by the help of embryology, are comparatively common.

3. **The Vulva.** — The mode of development of the external organs of generation is more complicated than, and not so well understood as that

<sup>1</sup> For further information on the homologies of these structures, see (1).



of the vagina and uterus with its annexa. At the posterior or lower end of the embryo an invagination of the ectoderm occurs, by which the cloaca is brought into communication with the exterior, and thus is formed the cloacal opening or primitive anus. This is followed by an indifferent stage, during which it is impossible to foretell the sex of the embryo. The anterior part of the anal plate becomes thickened, and gives rise to a projection known as the genital tubercle, which is the anlage of the penis in the male, and of the clitoris and nymphæ in the female. In its indifferent stage it may be termed the phallus. On the under surface of the genital tubercle appears a groove—the genital groove—which passes backwards into the cloaca. In the female the lips of this furrow become the labia minora, and the integument outside them develops into the labia majora. Soon the cloaca is seen to be divided by a partition—the future perineum—into an anterior cavity, or uro-genital sinus, into which open the urinary and sexual ducts, and a posterior which opens at the permanent anus. In the female the genital tubercle remains small and imperforate, and the sinus urogenitalis persists as the vestibule into which opens the urethra (the drawn-out lower end of the allantois), and the vagina with its hymeneal fold.

From what has been said of the development of the external genitals, complicated as it is with that of the lower end of the bowel and urogenital ducts, it is not difficult to understand how many puzzling anomalies may arise, — anomalies which have led to errors in the determination of the sex of the infant at birth, and to most unhappy consequences in later life. One is, therefore, prepared to find that the principal malformation of the external genitals is that known as hermaphroditism, or by the better name of pseudo-hermaphroditism.

The mode of development of the generative organs must be constantly borne in mind in the study of the malformations to which they are subject; for many of these are thus at once capable of explanation. Certain anomalies, it is true, admit of no such easy elucidation; nevertheless it is probable that a more exact knowledge of the early stages of development, when obtained, will serve to clear up what is at present obscure. The primary etiological factor which interferes with, and arrests the development of the internal genital organs, may with some confidence be supposed to be foetal peritonitis. The malformations of the external parts may, on the other hand, be due to amniotic compression or adhesion.

**MALFORMATIONS OF THE OVARIES.** — It is only within recent years that special attention has been paid to ovarian anomalies, yet these disorders affect the sexual life and responsibilities of the woman, and may interfere with the success of such operations as oophorectomy or ovariectomy.

**Pathology.** — 1. *Supernumerary Ovaries.* — It is well to reserve the term “supernumerary ovary” for such rare cases as that reported by Winckel, in which a third ovary lay in front of the uterus, to which it was attached by a strong ovarian ligament. It also formed connections with the bladder and with the right Fallopian tube. The two normal

ovaries were of equal size, and there were no traces of peritonitis in their neighbourhood. The supernumerary ovary was twice the natural size. The patient, an old woman, was sterile, notwithstanding the abundance of ovarian tissue. No case exactly resembling Winckel's has yet been recorded, and the condition must be very rare. Embryology gives little help in solving its mode of origin. It may have been due to duplication of the sexual gland on one side; but Winckel suggests that it was developed from the anlage of the bladder (allantois), and that in this way its vesical attachment is explicable.

2. *Accessory or Constricted Ovaries.*—Accessory ovaries differ greatly from the anomaly which has just been described. They are much less rare, for they are found in from two to three per cent of autopsies; they are rounded bodies always smaller than the normal ovary, to which they have a pediculated, rarely a sessile attachment near its peritoneal border, and they vary in number from one to three. In a case observed by J. D. Williams, and seen by myself, the accessory ovary was of the size of a large pea; it was made up of ovarian stroma with Graafian follicles, and was attached to the anterior border of the right ovary by a stalk which consisted partly of fibrous tissue, with an external coating of low cubical epithelium, and partly of solid columns of epithelial cells enclosed in the fibrous tissue. In the above case there had been dehiscence of at least one Graafian follicle, for a cicatrix was found. An accessory ovary may become cystic. Mr. Doran has pointed out that small fibromyomas may arise in the ovarian ligament, and be mistaken for accessory ovaries; but in most of the recorded cases there seems to have been little doubt of the glandular character of the bodies.

Accessory ovaries are probably constricted portions of the normal organ which have been separated at an early period in the development, possibly by the agency of foetal peritonitis; in rare cases the ovary has even been found divided into two nearly equal parts by such a constriction. At the same time traces of peritonitis are not always present, and then it is possible that the accessory glands were produced by a form of budding of the primitive sexual gland. This latter hypothesis is strengthened by the fact that in some instances the accessory ovary consisted entirely of Pflüger's tubes. It is also possible that cases of this kind may have given rise to the notion that both ovary and testicle were present in the same individual, the accessory ovary with its tubuliferous structure being regarded as a testicle.

3. *Hypertrophy of the Ovary.*—Occasionally ovaries of twice the normal size have been found in the infant at birth. This may be due to hyperplasia of all the component parts of the gland; or to an increase in the connective tissue elements with destruction of the Graafian follicles, the result possibly of foetal oophoritis. In twin-bearing women the ovaries, according to Hellin, contain an unusually large number of ovisacs, a persistence, in fact, of the foetal character of the glands.

4. *Absence of the Ovaries.*—Complete absence of both ovaries, save in symphyal and acephalic fœtuses, is an exceedingly rare anomaly. It

can only be absolutely proven by a post-mortem examination of both pelvis and abdomen; for the glands may exist in a rudimentary state, or in an unusual position, and so escape notice clinically.

Absence of one ovary is also a rare defect, but its occurrence is well established. It is usually, but not invariably associated with absence of the corresponding half of the uterus (*u. unicornis*), and of the tube of the same side; one kidney is also wanting in certain cases. It would seem, therefore, that defect of the sexual gland is apt to carry with it absence of the Müllerian and segmental ducts and Wolffian body.

5. *Rudimentary State of the Ovaries.*—This is much less rare than complete absence of one or both ovaries. The glands are small in size and have either the foetal or the adult form. Microscopically they may show no Graafian vesicles; they may consist simply of connective tissue, with vessels and scanty muscular fibres, or they may exhibit a few ill-developed ovisacs in the midst of ovarian stroma. Sometimes, by the persistence of Pflüger's tubes in an unclosed state, they may simulate testicles. They may occupy their normal position; or, as in Blot's case, they may lie near the upper angle of the uterus; or, again, they may be found herniated in the inguinal canal. They may coexist with accessory ovaries, with rudimentary Fallopian tubes, with a bifid or foetal uterus, and with stenosis of the aorta. At the same time the uterus may be normal, and the ovaries rudimentary and conversely. Such defects in ovarian development may be due to foetal oophoritis or peritonitis, or to torsion of the pedicle of the gland.

6. *Displacement of the Ovaries.*—Non-descent of an ovary is a rare but not unknown anomaly. Mr. Bland Sutton has reported a case in which the right ovary was adherent to the lower border of the kidney of the same side, and I have seen a case in the new-born infant in which it was attached by peritonic bands to the caecum. It has been stated that it may be found free in the peritoneal cavity, or adherent to the omentum; it may then be cystic.

Instead of non-descent, there may be dislocation of the ovary downwards into the inguinal canal. According to Puech, congenital inguinal hernia of the ovary is much more common than acquired, and Zinnis has recently reported an instance of it; but Bland Sutton states that he knows of no case in which the ovarian nature of the herniated body has been proved by microscopical examination conducted by a competent observer. Herniation of the ovary, which may be unilateral or bilateral, is usually associated with displacement of the Fallopian tube, and sometimes with malformation of the uterus and malposition of the kidney. It may be due to defective development of the round ligament and a patent condition of the canal of Nuck. A congenital crural, ovarian hernia has not yet been observed.

**Clinical Features.**—The presence of *supernumerary* or *accessory ovaries* is no guarantee of fertility; for in certain of the recorded cases the patients, although married, had not borne children. The woman seen by Olshausen, however, had had three confinements. Sterility in these

cases is to be accounted for by the cystic or atrophic state in which the ovaries, both normal and accessory, are often found; and possibly the foetal peritonitis, which caused the division of the gland, led also to destruction of the ovisacs in it. In another direction, however, accessory ovaries have a certain clinical importance; their presence may explain the occasional persistence of menstruation after double ovariectomy or oophorectomy, as has been pointed out by Homans and others; the removal of three entirely separate ovarian cystomata or dermoids is rendered possible, as in Sippel's case; and the occurrence of pregnancy after a double ovariectomy finds a very probable explanation. Their diagnosis must always be a matter of great difficulty; but their occasional presence must be borne in mind when small bodies are felt in the pelvis near to, or even at some distance from the normal ovaries.

The clinical importance of *absence* or of a *rudimentary state of the ovaries* depends greatly on the unilateral or bilateral character of the anomaly. If only one ovary be absent there may be no interference with the patient's reproductive power; for in the case reported by Busch, and quoted by Lawson Tait, the woman, notwithstanding unilateral absence of tube and ovary, had borne ten children. When, on the other hand, both ovaries are wanting or imperfect, indications of the defect are usually forthcoming at the time of puberty. Then there is an absence of the changes peculiar to this age, such as the establishment of the menstrual flow, the growth of hair on the mons veneris, and a rounding of the figure; the individual approximates rather to the male than to the female type, or possibly retains the characters of infancy, with or without idiocy or cretinism. Exceptions occur, however, in which the woman shows the normal female character and has active sexual desire. Epilepsy may occasionally appear at the period of puberty; Skene believes that defective development of the ovaries is of importance as a cause of mental weakness, and even of insanity, for normally the brain is stimulated to higher development by the demands of these organs. There would seem also to be more than an accidental connection between chlorosis and imperfectly formed ovaries. In adult life sterility is the constant result of a bilateral absence of the sexual glands; and it may be accompanied by the growth of hair on the face, and especially on the upper lip.

It is extremely difficult, if not impossible, to determine during life the existence of the ovarian defects under consideration: vaginal, rectal, and vesical touch, even when combined with abdominal palpation, often fail to establish a sure diagnosis; and nothing short of laparotomy gives certainty. Yet it is very important that the anomaly should be detected, or at least suspected, if only to save the patient and her medical attendant from the dissatisfaction and disappointment consequent upon the employment of a long and futile course of treatment for the establishment of menstruation by means of stem pessaries and the like. Even when fairly conclusive evidence of the rudimentary state of the ovaries exists it, is by no means certain that the lesion is truly congenital,



for scarlet fever and other zymotic affections occurring in childhood may lead to their injury.

*Ovarian hernia* is suggested by the presence of a rounded or oval body in the inguinal canal or labium majus, whether on one or both sides, when it occurs in an individual with a uterus and external genitals of the female type. For a certain diagnosis of the displaced gland microscopical examination is necessary, but the absence of the ovary from its normal position in the pelvis as determined by bimanual examination, the enlargement of the herniated body at the menstrual periods, and the existence of dysmenorrhœa and dyspareunia, usually justify the provisional diagnosis of inguinal ovarian displacement. It must be borne in mind that the dislocated gland may undergo cystic changes which will mask its true nature. With regard to treatment, attempts at reduction almost invariably fail; and palliative measures, such as wearing a hollow pad over the ovary, are rather indicated. When the gland becomes inflamed or cystic, ovariectomy will be necessary; but when it is healthy it ought not to be removed, for pregnancy has been known to occur even with double ovarian hernia.

**MALFORMATIONS OF THE FALLOPIAN TUBES.** — Since it has become customary to perform abdominal section for the relief of various morbid states of the viscera, attention has been more specially directed to the study of the malformations of the Fallopian tubes; and it is now known that these ducts may exhibit many anomalies with some of which earlier writers were unacquainted. The exact bearing of these abnormalities upon the physiology and pathology of reproduction is not fully determined; but there is reason to believe that ectopic pregnancy may, in some instances at least, be due to developmental errors in the tubes. Tubal anomalies, like those of ovaries, may be roughly classified into those of excessive formation, those of defect, and those of altered relation. These terms, however, must not be taken in a strictly literal sense.

**Pathology.** — 1. *Supernumerary Fallopian Tubes.* — Examples of complete duplication of the tube, like genuine cases of supernumerary ovary, are extremely rare; the two conditions may be associated. Instances have been reported by Keppler, Falk, and Ruppolt; the last named author was of opinion that in his case the tube and ovary had been divided into two parts by the action of fatal peritonitis.

2. *Accessory Tubal Ostia and Tubes.* — Another tubal malformation, which may be reckoned among those "by excess," is the presence of accessory ostia or tubes. Opinions vary as to their frequency; Richard found them as often as five times in thirty cases; Kossmann noted them in from 4 to 10 per cent; and J. D. Williams and the present writer observed two examples in sixty-one consecutive autopsies (Fig. 31). From 3 to 6 per cent is doubtless the usual proportion. Until recently more than three accessory ostia on one tube had not been observed, and commonly there are one or two only; but Ferraresi has put on record a remarkable case in which there were six. The ostia are either sessile or have

pedicles consisting of accessory tubes; they are usually surrounded by fimbriæ. They are generally situated near the normal abdominal opening, and on the upper convex border of the tube; but sometimes they lie midway between the normal ostium and the uterine end of the oviduct. Usually they communicate with the tubal lumen. Doran explains the origin of accessory ostia by partial failure in the closure of the groove in the germinal epithelium which forms the upper part of the Müllerian duct; at the same time he thinks that they may also be due to splitting along the outer edge of Müller's duct after it has formed a closed tube. Kossmann, however, believes that they are occasioned by

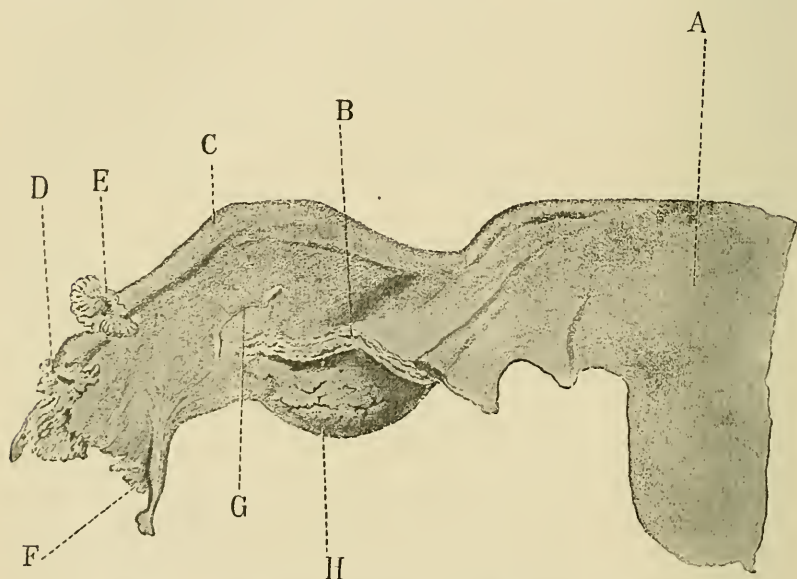

FIG. 31.—Anterior view of right uterine appendages, showing accessory abdominal ostium of tube. A, Uterus; B, cut surface of mesovarium; C, right Fallopian tube; D, fimbriated extremity; E, accessory ostium abdominale; F, free fold of anterior layer of mesosalpinx; G, pedunculated cyst; H, right ovary.

the existence of a supernumerary embryonic “anlage” (rudiment), lying parallel to the primary one.

3. *Tubal Appendages or Accessory Fimbriæ*.—Ferraresi gives the name tubal appendages (“appendici tube”) to certain structures, not uncommonly met with, which may be identified with the “pedunculated tufts of fimbriæ” described by Bland Sutton. Superficially they bear a resemblance to accessory ostia, but their stalk is solid, and they show no ostium. Ferraresi found them six times in forty cases, and when present they occupy the same positions as accessory ostia; two have been seen on the same tube. Bland Sutton regards them as ruptured cysts of Kobelt's tubes; but more probably they have the same origin as the accessory fimbriated ostia.

4. *Anomalies in the Length of the Tubes.*—In cases of ovarian hernia the tube has often an unusual length. Even when there is no such displacement it may attain abnormal dimensions—16 to 17 cms. in length according to Sinéty. The normal length is from 10 to 11 cms., and the longest tube met with by J. D. Williams and myself measured 14 cms.

The tubes may also be of unequal length—sometimes the right, and at other times the left being the longer. Winckel says with regard to primary or congenital inequalities, that the embryonal causes may be an unequal length of the “anlage,” irregular position, restricted motion from the pressure of neighbouring organs, or increased traction from foetal peritonitis.

5. *Absence of the Fallopian Tube.*—Absence of the tubes may be

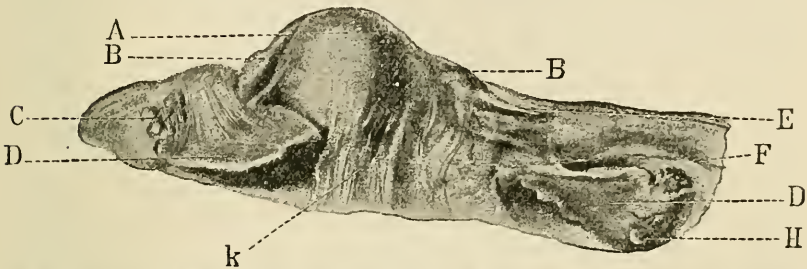

FIG. 32.—Congenital absence of outer two-thirds of right Fallopian tube. (Post. view.) A, Fundus uteri; B, B, tubercular nodules in isthmus of each Fallopian tube; C, parovarian cyst; D, D, ovaries; E, cone-like end of right Fallopian tube, outer two-thirds being absent; F, cut margin of right mesosalpinx; H, fibroma of right ovary; k, adhesions on posterior wall of uterus.

bilateral; but more frequently one only is wanting. In the former case the defect is usually associated with absence of the uterus; whilst in the latter the uterus unicornis is commonly present, the absent uterine horn being on the same side as the absent tube. Colomiatti, however, has reported a case in which the vagina and uterus were well formed, and yet the right tube and ovary were absent. Unilateral defect of the tube usually carries with it absence of the ovary; but this is not invariable, for in Blot's specimen the gland was present but rudimentary. In certain instances the corresponding kidney is also wanting. The want of development of the upper part of Müller's duct is doubtless the cause of the anomaly; when the whole duct is absent there is also a unicornate uterus.

6. *Rudimentary State of the Tubes.*—In rare cases the outer part of the tube is absent; thus, in a case of genital tuberculosis, J. D. Williams and the writer noted congenital absence of the outer two-thirds of the right oviduct, the inner third having a lumen and tapering to a point at its outer end (Fig. 32). In a post-mortem room specimen Sir T. Grainger Stewart observed that the tubes were shorter than normal, ended blindly, and were connected by bands with the peritoneum covering the rectum. Absence of the outer part of the tube does not necessarily carry with it defect of the corresponding ovary; but in the case seen by Marehand it

did so. Doubtless the anomaly is due to foetal peritonitis. Sometimes only the fimbriæ of the ostium abdominale are wanting.

Partial or complete absence of the normal tunnelling of the tubes may be met with; and then these organs are represented by solid cords of fibrous or muscular tissue. Sometimes it is at the abdominal end only that the tube is imperforate: in the case described by Dr. Haultain the outer extremity of one tube was quite smooth, like the finger of a glove; the tubal mucosa showed no folds, and the ovary on the same side was cirrhotic and cystic. Absence of the tubal lumen is simply the persistence of the normal condition of the embryo; whilst an imperforate state of the ostium abdominale must be due to want of development of the Müllerian funnel which should open into the splanchnocele.

During foetal life the tubes normally exhibit spiral convolutions both in the isthmus and ampulla; at birth these have disappeared in the isthmus, and in the adult they ought to be entirely absent. Sometimes, however, the convolutions persist, as in some of the specimens described by Popoff; but Haultain is of opinion that tubal contortion in the adult is more commonly due to a return to the foetal state than to a persistence of it. If endosalpingitis occur in such a tube it is easy to understand how hydrosalpinx or pyosalpinx may be initiated.

7. *Displacement of the Tubes.* — It is stated that the tubes may show an unusually low implantation into the uterus — a misplacement which has been regarded as one of the causes of placenta prævia. Displacement of the tubes in various directions may be the result of foetal peritonitis, as in a specimen shown by myself to the Edinburgh Obstetrical Society; and in cases of ovarian hernia the tube usually accompanies the gland. A curious case of backward dislocation of the tubes, with union of their abdominal ostia to form a ring behind the uterus, was reported by Hüter; but some doubt existed as to the congenital nature of the anomaly.

8. *The Hydatid of Morgagni.* — This name is often loosely applied to pedunculated cysts arising from the curved tubules of Kobelt (parovarium), or to stalked terminal cysts of Gärtner's duct; but it ought to be reserved for the much less common cyst which is found attached by a pedicle to the tube or to its fimbriæ. J. D. Williams and myself met with it in 8 per cent of the adult cases examined by us; it varies in size from that of a pea to a small bean; it is lined by a mucosa with simple folds covered by a single layer of ciliated columnar epithelial cells; its wall is always composed of muscular fibres arranged circularly and longitudinally; its outer membrane is the peritoneum; its stalk is always muscular; and its contents are clear, limpid fluid. Thus it may be distinguished from the false hydatids of Morgagni. It has been regarded as the remnant of the upper end of Müller's duct.

**Clinical Features.** — Malformations of the Fallopian tubes are seldom diagnosed during life. They may be discovered during the performance of laparotomy, or their existence may be suspected when anomalies of the uterus or ovaries are known to be present; but the



symptoms to which they give rise are not distinctive, and the physical signs associated with them are most difficult of recognition.

*Absence or imperforate condition* of the tubes, if bilateral, will be the cause of sterility; and if in such cases the ovaries be present, the rupture of Graafian follicles and the discharge of ova into the abdominal cavity may occur at menstrual epochs, with the consequent formation of small hæmatoceles and the occurrence of localised peritonitic attacks. Unilateral absence or imperforation is not a bar to conception, for the tube of the opposite side may transmit the ovum to the uterus. *Spirality* of the tubes or *displacement* may be causes of dysmenorrhœa and also of sterility. It has been thought that an *accessory ostium* may be a factor in the production of ectopic pregnancy — the ovum passing into the tube by the normal ostium, becoming impregnated, and passing out into the peritoneal cavity by the accessory orifice — but there is no proof that this can happen. On the other hand, Sânger has recently shown that an accessory ostium may serve for the ovum, as a means of access to the tube and uterus when the normal tubal openings are closed on both sides by inflammatory processes.

**MALFORMATIONS OF THE ROUND AND BROAD LIGAMENTS.** — Malformations of the round ligament are occasionally met with, but they have been little studied, and are doubtless commonly associated with abnormal states of the uterus, tubes, or ovaries. Persistence of the canal of Nuck, in which the ligament lies, gives rise to hydrocele in the woman. The broad ligaments, like the round, may be absent, rudimentary, or unequally developed. The ligamenta lata also may be congenitally displaced; and they often contain within their folds cysts which have developed in the mesonephric relics which form the organ of Rosenmüller or parovarium.

**MALFORMATIONS OF THE UTERUS.** — Malformations of the uterus form a large and interesting group of genital anomalies, the mode of origin and clinical manifestations of which have long been the subject of extended investigations. The various types of uterine anomaly are, therefore, well known: their pathogenesis is, with one or two exceptions, agreed upon, and their influence on the general and sexual health of the individual is, to a large extent, understood. Saint-Hilaire, Kussmaul, Fürst, Lefort, and Klebs have all by their researches greatly increased our knowledge of uterine malformations.

Various plans of classification have been proposed, of which that by Livius Fürst is the most complete and philosophical. He divided all anomalies of the uterus into three groups, according to the period of intra-uterine life in which they were produced — those originating between the first and eighth weeks, those between the eighth and twentieth, and those between the twentieth and fortieth weeks. In the first group were partial or total absence of the uterus, and a solid or partly excavated condition of the organ, which might be single, double, or bicornate. In the second group were certain minor malformations characterised by

trifling alterations in external form, and by the presence of a more or less marked septum internally. The third group contained a single variety, the uterus which retained its foetal characters so far as the presence of rugæ and the disproportionate size of cervix as compared with the body of the organ were concerned. This scheme, although invaluable to the teratologist, deals too much with minor details for the practical purpose of the gynæcologist. It will be convenient simply to divide uterine anomalies, like those of the tubes and ovaries, into three groups: those in which there is apparent excessive formation, those in which defect is the leading character, and those which show altered relationship of parts. The word *apparent* is inserted, because that which is commonly called a "double" uterus is really an organ the two component parts of which, derived from the two Müllerian ducts, have not fused into one. It will be well to study together the pathology and symptomatology of each variety, for several of them are of considerable interest and importance from the gynæcological standpoint.

**Uterus Accessorius and Trifid Uterus.**—*Pathology.*—The uterus accessorius and the trifid uterus are probably the rarest anomalies of that organ which have been recorded. In 1894 Holländer, during the performance of laparotomy, found a second uterus lying in front of the normal one, between it and the bladder. This he termed a "uterus accessorius." The normal organ was supplied with normal tubes and ovaries, had the round ligaments attached to it, and was retroflexed. The accessory uterus had neither annexa nor round ligaments, was anteverted, and contained some placental tissue. There was a single cervix with two orifices separated by a bridge of tissue. Each orifice communicated with the interior of one uterus. In a similar case, observed clinically by Skene, there was a small second uterus lying in front of the normal one.

Depage, also during a laparotomy, found a still more complicated and puzzling uterine anomaly, which he termed "trifid uterus." There was a bifid uterus with a single cervix and two internal cervical orifices; but there was also found, attached to the cervix, a third uterine lobe forming a closed sac containing altered blood. Blood cysts were found in the ovaries.

It is difficult to offer a satisfactory explanation of the mode of origin of these two malformations. It might be thought that in the case of the uterus accessorius we had to do with a uterus didelphys in which rotation had brought the two horns into an antero-posterior relation; but this supposition utterly fails to explain the attachment of the annexa and round ligaments to one uterus. The most feasible explanation of both the accessory and the trifid uterus is that during embryonic life a diverticulum is formed from one of the Müllerian ducts, and that this develops into the supplementary organ. If this be so, these anomalies fully deserve to be called malformations "by excess," which the so-called "double" uterus does not.

*Clinical Features.*—Holländer's patient had had seven labours, and had thrice aborted, once with twins, at the fourth month. The placental

tissue was found in the uterus accessorius, that is, in the organ without annexa. Skene's patient suffered from leucorrhœa from the accessory uterus. The case seen by Depage was in a young unmarried girl; and in this instance, as well as in that of Holländer, an entirely erroneous diagnosis was made, and the true state of affairs was discovered during laparotomy.

**Uterus Didelphys.** — *Pathology.* — The uterus didelphys — or, as it has

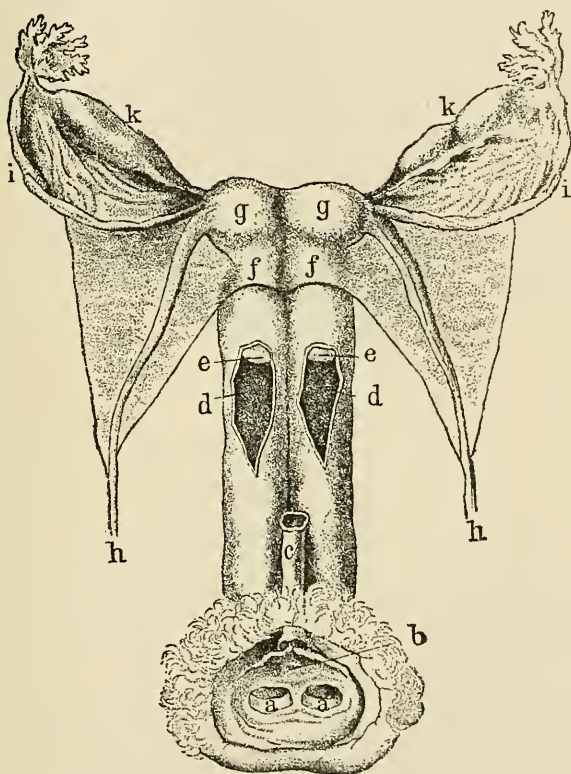

FIG. 33. — Uterus didelphys. (After Eisenmann and Martin.) *a, a*, Double vaginal entrance; *b*, urethral opening; *c*, urethra; *d, d*, double vagina; *e, e*, double cervical orifice; *f, f*, double cervix; *g, g*, double uterine body; *h, h*, round ligaments; *i, i*, Fallopian tubes; *k, k*, ovaries.

also been named, “diductus,” “duplex,” or “separatus” — exhibits the maximum degree of separation of the two laterally placed halves which normally fuse into the single uterus (Fig. 33). There appear to be two single uteri lying side by side, each, however, possessing only one ovary, tube, and round ligament. There may, also, be complete or incomplete duplication of the vagina (*septa* or *subsepta*); or that canal may be single (*simplex*). The two wombs are seldom exactly equal in size, and one of them may be imperforate, a condition giving rise to hæmatometra at

puberty. Not uncommonly this uterine malformation is associated with deformities of neighbouring parts, such as ectopia vesicæ and atresia ani. Among the causes which have been invoked to explain the want of union of the two Müllerian ducts, and the consequent formation of the uterus didelphys, are distension of the allantois, the absence of closure of the anterior abdominal wall, and the existence of adhesions between the rectum and bladder.

*Clinical Features.*— Since it is impossible clinically to separate cases of uterus didelphys from those of uterus bicornis, it will be convenient to consider the symptomatology of the two malformations together.

**Uterus Bicornis.**— *Pathology.*— A much commoner malformation is the uterus bicornis, in which the two halves or horns are not entirely separate, as in the didelphous organ, but are united more or less intimately at their

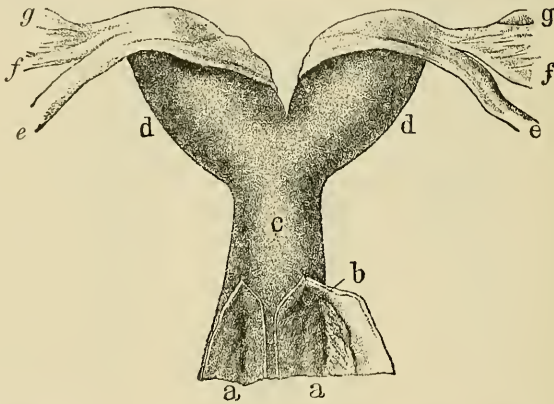

FIG. 34. — Uterus bicornis. (After Schröder and Martin.) *a, a*, The vagina, laid open; *b*, the left cervix; *c*, the cervix, externally apparently single, but divided into two internally; *d, d*, the two uterine horns; *e, e*, the round ligaments; *f, f*, the Fallopian tubes; *g, g*, the ovaries.

lower end; that is, in the region of the cervix or lower part of the corpus uteri (Fig. 34). The middle portions of Müller's ducts have evidently begun to fuse together, but coalescence has stopped short of the normal, and an organ is produced exhibiting externally clear indications of its two-horned origin. The bicornate uterus is the connecting link between the *uterus didelphys*, in which the external appearances show two quite ununited halves, and the *uterus septus* or *bilocularis*, in which outwardly the organ gives no indication of duplicity. The uterus bicornis also shows all the possible grades between the variety in which there are two horns united only in the cervical region, and that in which the double character of the organ is indicated merely by a depression or notch at the fundus (*uterus introrsum arcuatus* or *uterus cordiformis*). The two horns may be practically equal in size; but, on the other hand, one may be much less developed than the other, and in this way there is an approximation to the type of the uterus unicornis. All the intermediate varieties have



been observed. The degree of separation of the horns varies greatly. In the most marked cases they are far apart superiorly, and between them is frequently found a band or frenum (recto-vesical ligament) passing from the bladder to the rectum. In less evident cases the horns lie close together, but are not united; and in yet other instances a shallow depression at the fundus shows that fusion of the two Müllerian ducts has closely approached the degree found in the normal uterus. When the horns are markedly separate the left one is usually directed slightly forwards, showing that some degree of uterine torsion has occurred. In other cases they may lie exactly side by side.

The cervix uteri may be broad and large, and may show a double orifice (*uterus bicornis duplex, septus, or bicameratus*); it may be large, but with only one os; or it may be of normal size and provided with a single orifice (*uterus bicornis unicollis*). The vagina may be septate, subseptate, or single, and the external genitals are usually normal. Sometimes there are anomalies of neighbouring or more distant organs, for example *ectopia vesicæ* and *polydactyly*; and such monstrosities as *cyclopia* and *anencephaly* have been noted in non-viable infants with this type of uterine anomaly.

With regard to the internal appearances of the uterus bicornis it is common to find a septum dividing that part of the organ which appears single externally into two compartments internally. In other cases one or both horns may be solid, semi-solid, or imperforate at one or more places. In such instances an accumulation of blood may occur at puberty behind the imperforation. The cervix may show a double or a single canal.

*Clinical Features.* — Apart from the reproductive functions the uterus bicornis has little clinical importance; but it has recently been noted that chlorotic girls are not infrequently the subjects of this type of anomaly, and probably chlorosis is to be regarded as a developmental morbid state. It has been affirmed also that in early life difficulty may arise in the evacuation of the bladder and bowel from the concomitant malformations.

The menstrual functions may be variously affected by the presence of a didelphous or bicornate uterus. Menstruation may occur every fortnight, every month, or once in two months. In the first case the discharge comes from both uterine cavities each month, but there is no coincidence of dates, and therefore it has a fourteen day interval. In the second case there is either a simultaneous discharge from both wombs, or else the menstrual flow is from one cavity the one month and from the other the next. And in the third instance, as is shown by a case reported by T. A. Emmet, there is a bimonthly flow from one half, whilst on the other side there is an imperforate condition of the horn, vagina, or hymen, which prevents the appearance of a discharge. Dysmenorrhœa is often met with and amenorrhœa occasionally.

Sterility is sometimes associated with the bicornate uterus, but, on the other hand, the patient is often fertile. Pregnancy may occur in one horn, and a menstrual discharge take place from the other; a circumstance which possibly accounts for the continuance of menstruation during

gestation which has been occasionally noted. Decidual membranes may also form in the empty horn. Pregnancy may also occur in both horns simultaneously, or at different but not far distant dates; and in the latter case may be found the explanation of some of the anomalous instances of superfœtation. There is evidence to show that gestation may happen in each horn alternately. In rare cases a twin conception has taken place in one horn.

The bicornate uterus may abort; or labour may occur at the full term, when the empty horn may show contractions as well as the gravid one, and its os also may open. Parturition may be normal; there may be a malpresentation; the recto-vesical band may cause delay in the passage of the fœtal head, or there may be low implantation of the placenta and hæmorrhage. When, as sometimes happens, the pregnant horn is shut off by a septum, gestation becomes practically extra-uterine, and has all the dangers associated therewith, such as uterine rupture. Even in cases in which there is not unilateral atresia, rupture of the uterus, or of the septum between its horns, may occur.

The diagnosis of the presence of a bicornate uterus is often not made till pregnancy and labour have taken place; and sometimes not even then. When menstruation occurs every fortnight, or persists during pregnancy, the anomaly may be suspected. The presence of a double vagina, cervix, or os uteri suggests the existence of a double uterine cavity; and a thorough bimanual examination, conjoined with the careful use of the sound, if there be no evidence of pregnancy, ought to clear up the case. The instances in which one horn is imperforate are rarely diagnosed.

**Uterus Septus.** — *Pathology.* — The uterus septus, or, as it is also called, bilocularis or globularis, by its external appearance gives no indication of

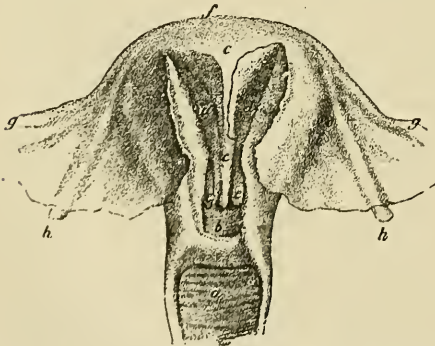

FIG. 35. — Uterus septus. (After Gravel and Martin.) *a*, Vagina; *b*, single, lower part of cervix; *c, e*, septum, thicker above, thinner below; *d, d*, right and left uterine cavities; *e, e*, two projections near the os internum uteri; *f*, fundus uteri; *g, g*, Fallopian tubes; *h, h*, round ligaments.

the fact that internally it is divided, more or less completely, into two cavities by an antero-posterior vertical septum or partition (Fig. 35). The cases in which the septum is imperfect have, however, also been grouped together under the name *uterus subseptus*, or *semipartitus*; and, according to the extent of the partition, certain subvarieties have been distinguished. Thus, when it is found in both body and cervix, leaving, however, the os externum uteri single, we have the *uterus subseptus unifornis*. When

it exists in the body, but does not extend beyond the os internum, there

is produced the *uterus subseptus unicollis*. When it is present only in part of the body it constitutes the *uterus subseptus unicorporeus*; and when it is found only near the os externum it is the *uterus biforis supra simplex*. From this enumeration of its varieties the pathological characters of the uterus septus will be evident. It may be added that the best-marked type has a normal fundus, two uterine cavities situated laterally, and existing both in body and cervix, and not infrequently there is also a partially or completely septate vagina. The uterus septus shows, therefore, a more advanced degree of fusion of the Müllerian ducts than does the uterus bicornis; but still the fusion is incomplete, as is shown by the more or less perfect septum which remains.

*Clinical Features.* — What has been written regarding the clinical manifestations associated with the uterus bicornis may be applied also to the uterus septus. Further, an incomplete septum may be the cause of a malpresentation — for instance, a transverse case — or of a low insertion of the placenta. The after-birth may even be attached to the septum itself — an arrangement certain to give rise to dangerous hæmorrhage after the birth of the infant. It would seem that abortion is common in this uterine anomaly; at any rate Ruge, by dividing the septum in the case of a patient who had twice miscarried, was rewarded by finding that her next pregnancy went to the full term. The diagnosis of the uterus septus is only likely to be made during labour, when the hand, introduced into the uterus to perform version or to extract the placenta, may detect the presence of the partition. As with the uterus bicornis one cavity may not communicate with the vagina, and thus hæmatometra with its train of symptoms may arise.

**Uterus Unicornis.** — *Pathology.* — The uterus unicornis is an organ in which one horn alone is well developed (Fig. 36). There are two varieties: that in which the second horn is altogether absent (*uterus unicornis sine ullo rudimento cornu alterius*), and that in which there is a solid or hollow rudiment of it (*uterus unicornis cum rudimento cornu alterius solido seu excavato*). In the former case there is complete, in the latter partial defect of one of the Müllerian ducts. The uterus unicornis has really no fundus, the single horn inclining to one side of the middle line and tapering to a point at which it is continuous with the Fallopian tube, and where the round ligament is attached. The ovary thus comes to lie at the apex of the bent cone formed by the single horn and the corresponding tube. The cervix uteri is usually small and the vagina narrow, absent, or septate. The single horn may also be imperfectly developed, and may be solid or

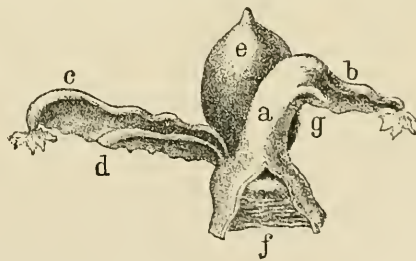

FIG. 36. — Uterus unicornis, posterior view. (After Pole and Martin.) *a*, Right half of uterus; the left horn has not been developed; *b*, right Fallopian tube; *c*, left Fallopian tube; *d*, left ovary; *e*, bladder; *f*, vagina; *g*, right ovarian ligament.

partly excavated. Certain concomitant malformations have been noted: thus, the Fallopian tube, round ligament, and broad ligament are commonly absent on the side of the missing horn; the corresponding ureter and kidney may also be wanting, and the bladder may be developed only on one side. The ovaries may be present, but are often rudimentary.

In some cases, as has been stated above, a rudiment of the second horn may be present; it may be solid or hollow, and in the latter case its cavity may or may not communicate with that in the first horn. Such cases form the connecting links between the typical uterus unicornis and the bicornate organ. This rudimentary horn may be the seat of a pregnancy, or a collection of menstrual blood may be found in it. A fibroid tumour may be found attached either to it or to the other better-formed horn, as in a case noted by Mangiagalli.

*Clinical Features.*—A patient with a uterus unicornis commonly gives a history of amenorrhœa; but sometimes menstruation goes on normally, and pregnancy occurs in the single horn. When a rudimentary horn is present, and when it becomes the seat of a gestation, a very serious state of affairs is established; in fact the case becomes practically one of extra-uterine pregnancy, and is accompanied by the same dangers, that is, rupture and intra-abdominal hæmorrhage. When the rudimentary pregnant horn has no communication with the uterus unicornis it seems necessary to admit extra-uterine migration either of the ovum or of the semen.

The presence of a uterus unicornis, with or without a rudimentary horn, commonly passes unnoticed during life; unless it be discovered during the performance of laparotomy. If the condition be suspected, a careful bimanual examination, aided by the use of the sound, will reveal the presence of a thin, elongated uterine body bent to one side with its concavity outwards. There will also be a small cervix and a narrow vagina. Pregnancy in the rudimentary horn cannot be distinguished from an ectopic gestation of the tubal variety, unless rupture occur and the abdomen be opened. In a case seen by myself it was mistaken for a fibroid tumour, a mistake which laparotomy revealed.

**Uterus Rudimentarius.** — *Pathology.* — The name uterus rudimentarius is a vague one. From one point of view it may with propriety be applied to such anomalies as the uterus unicornis or bicornis. Further, the distinction between it and complete absence of the organ can only be made after a careful autopsy. At the same time, it has been customary to restrict the application of the term to the cases in which, in place of the normal organ, one finds a body of variable form consisting of fibrous, muscular, or fibro-muscular tissue, sometimes solid and at other times showing a rudimentary cavity (*uterus rudimentarius solidus, uterus rudimentarius partim excavatus*). Through its partly excavated variety it is closely related to atresia of the single uterus. In one form of the rudimentary uterus the walls are so thin that it has been called *membraniform* or the *uterus membranaceus*. More commonly, however, a small solid mass of muscular tissue is found in the middle line between the



folds of the broad ligament, which seems in such a case to sweep in an almost unbroken band from one side of the pelvis to the other. The tubes, ovaries, cervix, and vagina are usually absent or very imperfect; but cases have been reported in which the annexa were normal. The external genitals are, as a rule, well formed. The mammæ are usually small, and there is often a poor growth of hair on the mons veneris.

*Clinical Features.*— Since clinically the rudimentary uterus cannot be distinguished from absence of the organ, the symptomatology of the two conditions will be considered together. The recent literature of both anomalies will be given at the same time.

**Uterus Deficiens seu Defectus Uteri.**— *Pathology.*— Complete absence of the uterus, its annexa, and (to some extent also) the external genitals, is met with commonly enough in the acardiac twin and in symphyoal fœtuses; but its occurrence in the adult and otherwise normal individual is very rare. It is necessary to make a complete post-mortem examination before it can be definitely said that no uterus existed; and in most of the reported cases such evidence is not forthcoming. Further, in certain instances the individual was evidently a male with undescended testicles, not a female without a uterus.

When the Fallopian tubes as well as the uterus are absent the peritoneum passes directly from the bladder to the rectum; but when they are present it forms a mesentery for each, although even then broad ligaments in the strict sense of the term can scarcely be said to exist. The round ligaments are generally to be found; they end in the cellular tissue between the rectum and bladder. The ovaries may be absent, but generally they are present, and then they commonly contain no ovisacs; very rarely they are normal. The tubes when present are simply solid rods of tissue, with usually an open ostium abdominale. The vagina is often wanting entirely; but sometimes there is a shallow *cul-de-sac* (vestibular canal) communicating with a vulva which is usually normal. There may, however, be an absence of the vulvar hair. In rare cases the vagina has been found well developed. The pelvis has a feminine breadth; but the mammæ are often poorly developed.

*Clinical Features.*— A woman without a uterus, or with merely a rudimentary one, may have all the secondary characters of her sex; she may have a high-pitched voice, rounded outlines, and an absence of hair on the face. Sexual desire may or may not be present—a circumstance which is probably determined by the state of the ovaries. Amenorrhœa is practically constant; as, however, ovulation may occur, menstrual molimina may be met with, and there may be vicarious hæmorrhages or such acute pelvic pain as to necessitate an operation for the removal of the ovaries. There is, of course, sterility always; but the patient may be capable of coitus to a certain extent. Usually, however, cohabitation is attended by great pain. Repeated attempts on the part of the husband deepen the shallow vestibular canal, converting it into a *cul-de-sac* of some depth; in other cases dilatation of the urethra is brought about.

Although it is impossible clinically to distinguish between absence and a rudimentary state of the uterus, it is always possible to ascertain the existence of one or other of these anomalies. By passing the index finger into the rectum and a sound into the bladder, whilst the abdominal wall is deeply depressed from above, one can determine that there is nothing like a fully formed uterus between the rectum and the bladder. A transverse band consisting of the tubes may be palpated, as may also the ovaries when they are present. These physical characters taken in conjunction with the symptoms enable the gynæcologist to make a diagnosis sufficiently exact to prevent his continuing a hopeless course of treatment by ferruginous tonics and the like for the establishment of menstruation.

**Uterus Fœtalis.** — *Pathology.* — The anatomical characters, which are normal in the uterus during intra-uterine life, may persist and be found in the adult. They then constitute an anomaly — uterus fœtalis. The cervix uteri is longer than the body, and its walls are thick, whilst those of the body are thin. The cervix also is conical and os externum narrow. The whole organ is cylindrical in form, and is small in size, the sound passing in for a distance of only an inch or an inch and a half. The term *infantile uterus* may be used as a synonym for fœtal uterus; but a shade of difference has been recognised by some writers. In the uterus fœtalis the folds of the mucous membrane are found in the body of the organ, whilst in the infantile organ they exist only in the cervix. The mucous membrane also is poorly developed, and, according to Sinéty, contains no tubular glands. The vagina may be short and narrow, or it may be quite normal. The external genitals may be imperfect, and the ovaries and tubes may either be normal or rudimentary. Mammary development is usually little marked. It may be added that the uterus fœtalis may be also a *uteris bicornis*.

*Clinical Features.* — With the uterus fœtalis there is commonly amenorrhœa; sometimes, however, there is scanty and painful menstruation. Sterility is a constant symptom, and there may or may not be sexual appetite. Chlorosis has frequently been found associated with a fœtal or infantile uterus. The heart may be small, and there may be a general hypoplasia of the whole vascular system. The uterine anomaly may be diagnosed by means of bimanual examination, aided by rectal touch and the use of the sound. The differential diagnosis between the uterus fœtalis and the uterus pubescens is chiefly founded upon the state of the cervix. In the former it is fairly firm, especially in the supra-vaginal portion; in the latter it is thin and relaxed. The condition, however, may be complicated and to some extent masked by concomitant perimetritis and metritis. Attempts at treatment of the anomaly have almost invariably ended in failure; and practically the only thing to be done is to relieve the dysmenorrhœa, if it be present, by the use of drugs, or possibly, if severe, by oophorectomy.

**Uterus Pubescens.** — *Pathology.* — The pubescent uterus occupies an intermediate position between the uterus fœtalis and the normal virginal

organ. It shows a persistence of the anatomical characters which are normal before the epoch of puberty. The organ is small in size, weighs less than normal, and has a cervix and a body of practically equal length. The ovaries, tubes, vagina, and mammæ may or may not share in this condition of hypertrophy.

*Clinical Features.* — The symptoms of pubescent uterus closely resemble those associated with the foetal or infantile organ. Menstruation may be absent or scanty and irregular. Sterility is common, but there is always the hope that the organ may yet undergo further development and the patient become pregnant. Signs of general weakness, chlorosis, or rickets may coexist; but the anomaly may also be met with in strong and healthy women. The diagnosis is made by the same means as in cases of foetal uterus, especial attention being paid to the condition of the cervix and its size compared with that of the body of the organ. If the condition be discovered before marriage, the treatment to be adopted is a general tonic one, consisting in the use of gymnastic exercises, of nourishing food, and of iron, quinine, and arsenic. After marriage the periodical passing of the sound, the insertion of an intra-uterine stem-pessary, and electricity may all be employed with some hope of success. The effect of marriage itself may be beneficial; emmenagogues are of doubtful efficacy. Marriage ought not to be recommended unless menstruation has become established.

**Uterine Atresia and Stenosis.** — *Pathology.* — The uterus may be congenitally imperforate; an anomaly which finds its explanation in the originally solid condition of the ducts of Müller from which it is developed. Uterine atresia is not so much an independent malformation as a complication of other anomalies of the organ, for instance of its bicornate and unicornate condition. Nevertheless it occurs also in cases of single and otherwise normal uteri. The whole cervix may be solid, or there may simply be a septum at the os externum or os internum uteri. At the age of puberty menstrual blood begins to accumulate behind the obstruction, leading in time to the distension of the uterus (hæmatometra). When one horn of a bicornate uterus is imperforate, unilateral hæmatometra is produced; when both horns are occluded there is bilateral hæmatometra. When the obstruction is situated at the os internum, only the body of the uterus becomes distended, the cervical canal retaining its natural form. An accumulation of blood may be found in the tubes also (hæmatosalpinx), and it would appear that the source of the blood is the tubal mucosa, and that it is not due to regurgitation from the uterine cavity. When there is simply narrowing of the cervical canal without atresia the condition known as uterine stenosis is produced.

*Clinical Features.* — Since the symptoms of uterine atresia are mainly those of hæmatometra, and since these are found also in association with atresia vaginæ, their consideration will be deferred till that vaginal anomaly has been described. In the cases of uterine stenosis dysmenorrhœa is the leading symptom, and dilatation of the cervical canal is needed for its cure. Uterine atresia requires puncture and subsequent

dilatation of the obstruction for its relief. This should be done with strict antiseptic precautions; and when the accumulated fluid has escaped the cavity should be packed with iodoform gauze for some days, and douched occasionally with weak antiseptic solutions.

**Transverse Septum in the Cervix Uteri.** — *Pathology.* — A condition somewhat similar to atresia uteri is the presence of a valvular fold or diaphragm in the cervical canal. When the os externum has been dilated the valve may present the appearance of a second cervix within the first. It is possibly produced in the same manner as the more common transverse septa of the vaginal canal.

*Clinical Features.* — The septum would seem to act like a polypus, and give rise to hæmorrhage and pain. It has been excised with complete relief of symptoms. It may also be the cause of dystocia; but this is not a constant effect.

**MINOR MALFORMATIONS OF THE UTERUS.** — Müller of Berne has recently pointed out the frequency of certain minor abnormalities of the uterine fundus. Amongst these is the anvil-shaped uterus (*uterus incudiformis* or *biangularis*), in which the normal convexity of the fundus is wanting, and a straight line joins the two Fallopian tubes. It closely resembles the uterus with a flat fundus (*uterus planifundalis*) of Fürst's classification, and may coexist with partial or complete duplication of the uterus and vagina.

The vaginal cervix may be rudimentary or absent (*uterus parvicollis* or *acollis*), whilst the body of the organ may be normal, small, atresic, or membraniform. A case of this kind has recently been reported by Penrose. Again, a frenum may be found dividing the os externum into two orifices (*uterus biforis*), a condition which is normal in the ant-eater (Pozzi). This exists without any other trace of duplication of the genital canal. It may complicate labour, during which it may be torn and give rise to hæmorrhage. In order to prevent this it ought to be kept to one side or divided between two ligatures.

A condition which may easily be mistaken for the uterus unicornis is that in which there is asymmetry of the organ, one side being better developed than the other. The uterus bends towards the better-developed side (latero-version or obliquity of the uterus), and the round ligament on that side is relatively short. Latero-position of the uterus is met with when one of the broad ligaments is less developed congenitally, and is to be distinguished from the acquired condition due to unilateral inflammation and cicatricial contraction.

**Congenital Prolapsus Uteri.** — *Pathology.* — What has been called congenital prolapsus uteri is an exceedingly rare anomaly. I have recently met with a well-marked example of it, in which there was a real displacement downwards of the whole uterus as well as a hypertrophic condition of the cervix. In my case, as well as in those of Heil, Quisling, Schaeffer, and Rémy, there was also spina bifida in the lumbo-sacral region. Now these five instances are the only ones with which I am acquainted; and



the fact that in them all there was this association of spina bifida and prolapsus uteri, seems to point to a nervous factor in the etiology of the latter condition.

**Abnormal Communications of the Uterus.**—The uterus may in rare cases communicate with the rectum or bladder, or with both viscera at once. In an extraordinary instance reported by Mr. Doran the right side of a bipartite uterus opened on the outer surface of the body. There may also be a communication between the uterine cavity and that of the ascending colon. Most of these anomalies must be ascribed to a partial or complete persistence of the embryonic cloacal condition. When combined with vaginal atresia it would seem that impregnation has occurred per rectum or per urethram.

**MALFORMATIONS OF THE VAGINA.**—Vaginal malformations have many characters in common with uterine anomalies, a circumstance which is easily understood when it is borne in mind that both vagina and uterus are derived from the Müllerian ducts of the embryo. Further, vaginal and uterine abnormalities often coexist in the same case, and in many instances give rise to very similar symptoms. Whilst, however, it is rare to meet with abnormal communications between the uterus and neighbouring organs, such communications are much more frequent in the case of the vagina.

**Double Vagina (Vagina Septa).**—*Pathology.*—A double vagina in the exact sense of the term can only be said to exist in certain double terata, such as the pygopagous twins; but it has become customary to apply the name to the cases in which the two Müllerian ducts, which normally fuse into one canal, have remained separate, a septum intervening between the two passages in part or in the whole of their extent.

Just as the uterus didelphys is very rare, so two vaginal canals, completely separated and each opening externally at a separate vulva, constitute an anomaly of a very uncommon form. The only reported case of the kind seems to have been that of Katharine Kaufmann, seen by Suppinger in 1876. This child, who died at the age of twenty-one months, had two vulvæ each opening into a vaginal canal. The pelvis was broad, and the true pelvis was divided into two lateral cavities by a peritoneal fold. Each half contained a bladder, a unicornate uterus with an ovary and a tube, and an intestinum rectum. The vertebral column began to divide at the level of the third lumbar vertebra, and the two coccyges were quite separate. This individual has been placed amongst the double terata.

Much more common are the cases of "double" or septate vagina, in which the vulva is single, although the hymen may show two openings. The two canals are separated by a longitudinal septum; in the great majority of cases this vertical septum runs antero-posteriorly, and the vaginæ, therefore, are situated laterally; in a very few cases only does it pass transversely, when of course the vaginal canals lie one in front of the other. In the latter case it must be supposed that the two unfused Müllerian ducts have undergone partial rotation. It is rare, however, to

find the two canals exactly lateral in position and exactly equal in size; one, usually the left, commonly lies a little in front of the other, and one is nearly always a little smaller than the other. The septum is composed of muscular tissue covered by mucous membrane, and has the consistence of the recto-vaginal septum. It varies, however, in thickness, and may even at certain places show perforations. It may extend the whole length of the canals, or it may be absent below and present above (*vagina infra simplex* or *septa supra*), or present below and absent above (*vagina septa infra* or *supra simplex*). In the least marked form there is only a ridge on the vaginal wall. In the great majority of cases the uterus also is double, and may be didelphous, bicornate, or septate, and then there is usually one cervical orifice in each vagina; but in a few recorded cases the uterus was single, although the vagina was double, when of course only one canal gave access to a cervix. Instances have also been reported in which the uterus was unicornate, then one of the vaginæ, that on the same side as the absent horn, was usually rudimentary. This last-named type, however, scarcely deserves to be termed a double vagina. The vulva and the hymen may be single, the vaginal septum stopping above the level of the ostium; but in some cases the hymen shows two lateral orifices separated by a bridge of tissue. There may be atresia of one or both vaginal canals, leading in the adult to unilateral or bilateral hæmatocolpos.

*Clinical Features.* — Double vagina does not usually give rise to symptoms prior to the occurrence of labour unless one of the canals be imperforate; then at the time of puberty blood may begin to collect behind the obstruction, and give rise to the troubles associated with hæmatocolpos and hæmatometra. It has been stated that during pregnancy the septum may be absorbed, but if it be still present at the time of confinement it may give rise to trouble by obstructing delivery. It may tear and labour go on naturally; on the other hand, the rupture of it may extend to the vagina and uterus also, and fatal consequences result. In yet other instances the septum is pushed to one side, and no delay in labour occasioned. Dyspareunia has been occasionally reported as an effect of the septate vagina. The diagnosis of the anomaly can be easily made by a vaginal examination, save in the cases in which one canal is imperforate; then the condition might easily be mistaken for a cyst of the vaginal wall. The simple septum may be safely divided by scissors during labour. When, however, there is an accumulation of menstrual blood in one-half of the canal it will be necessary to open the sac freely, more especially if the contents are purulent, and to pack the interior with iodoform gauze.

*Unilateral Vagina.* — In the rare cases in which only one horn of the uterus is developed (*uterus unicornis*) there is generally a similar condition of the vagina. In other words, the lower end of one of the Müllerian ducts has aborted, and the vaginal canal which exists represents one and not both of the embryonic tubes from which it is normally developed. This being so, it is not surprising to find that the vagina is

then narrow, and lies somewhat to one side of the middle line. The anomaly is so constantly associated with the unicornate uterus that any special description of it is rendered superfluous.

**Vagina Rudimentaria.** — *Vagina rudimentaria*, like the term uterus rudimentarius, is a vague expression. It denotes an anomaly which has also been described as simple atresia and lateral atresia vaginæ; and clinically no line of demarcation can be drawn between it and complete absence of the vagina (*defectus vaginæ*). It will therefore be discussed under those heads.

**Defectus Vaginæ.** — *Pathology.* — Complete absence of the vagina is a very rare condition — one which is met with chiefly in the allantoido-angiopagous twin fœtus and in the sireniform monstrosity. In it no muscular bands are found between the bladder and rectum, otherwise the condition falls into the category of vaginal atresia or rudimentary vagina. Probably it is always associated with absence of the uterus, Fallopian tubes, and external genitals, and with an imperfect development of the mammary glands.

*Clinical Features.* — Since this is a pathological, not a clinical morbid entity, the consideration of its symptoms will be taken with those of vaginal atresia, a condition from which it is undistinguishable during the life of the individual.

**Atresia Vaginæ.** — *Pathology.* — Vaginal atresia or imperforation is of different degrees. In its most marked form no trace of the canal is found save a fibrous or fibro-muscular band in the tissue between the bladder and rectum; in a less extreme form part of the vagina is present whilst the remainder is solidly imperforate; and in a still less marked form there is simply a membranous obstruction or perforated diaphragm at one part of the passage. Again, the position of the imperforation varies; it may exist throughout the whole length of the canal, or it may be present only at the upper part, the lower part, or the middle part. When the upper two-thirds of the vagina are occluded it has been supposed that the open lower third is not truly vaginal in nature, but is the enlarged vestibular canal, the representative of the anterior part of the sinus urogenitalis of intra-uterine life. Through the failure of the downward progress of the Müllerian ducts the vestibular canal has retained its early dimensions; its depth also has probably been increased by attempts at coitus. When only the middle part of the vagina is obstructed it may be surmised that the upper canal is Müllerian, or truly vaginal in character, whilst the lower portion is vestibular. With regard to the condition of the other genital organs in cases of vaginal atresia great differences exist. The uterus may be normal, rudimentary, or absent. The vulva also may be wanting or imperfect, but more usually it is normal and the hymen is present. The ovaries are commonly present. The urethral canal may be dilated, the result of attempts at coitus. Certain pathological changes commonly occur at puberty: if the uterus be present and the whole vagina imperforate, hæmato-metra is developed and the uterus converted into a large rounded

sac containing blood, first the cervix and later the body becoming distended; if the upper part of the vagina be patent, then blood first accumulates in it, and hæmatocolpos is produced, whilst hæmatometra is a later development; and if the vaginal obstruction affect only the lowest part of the canal, hæmatocolpos may be the sole result, the uterus remaining as a small body surmounting the distended vaginal tumour. Hypertrophy of the vaginal walls may be produced, or from the accumulation of blood rupture may occur into one or other of the neighbouring viscera. In certain instances the Fallopian tubes also become distended and hæmatosalpinx results. The contents of the distended vagina, uterus, or tube are usually treacly in character, consisting as they do of concentrated blood. After rupture or artificial evacuation suppuration may supervene in the sac, and pyocolpos, pyometra, and pyosalpinx be produced.

*Clinical Features.*—The symptoms associated with vaginal atresia are chiefly those due to the accumulation of blood in some part of the genital canal at and after the period of puberty. In early life, it is true, some discomfort may be caused by the retention of mucus in the patent part of the canal, leading to constipation and dysuria by pressure; but the special clinical features are all developed after puberty. There is, of course, amenorrhœa; then gradually, unless indeed the uterus be absent, a swelling is developed in the lower abdominal region in which fluctuation can often be detected. There is sometimes a bulging in the region of the vulva and perineum. These signs are caused by the gradual accumulation of menstrual blood behind the obstruction. Severe pelvic pain is experienced, recurring with increasing severity at intervals of a month; this is sometimes accompanied by vicarious menstrual hæmorrhages from other parts of the body, for example, hæmoptysis, or hæmatemesis. If the patient marry, cohabitation is found to be very difficult and painful, if not impossible. In time, however, the vestibular canal or urethra becomes distended, and an imperfect degree of connection is rendered possible; then the urethral dilatation leads to dysuria. There is of necessity sterility. In a case recently reported by Grandin the anomaly existed in several members of the same family.

The diagnosis of the anomaly ought not to be a matter of difficulty. When, in a patient with amenorrhœa and monthly pelvic pain of increasing severity, an abdominal tumour, which fluctuates and gradually enlarges, is discovered, the presence of vaginal atresia may be suspected; and when, in addition, it is found on examination that the vagina is blocked either near its orifice or at its upper part, the diagnosis may be safely made. Further examination by means of rectal touch, aided by the presence of a sound in the bladder, abdominal palpation, and vaginal touch (when the lower part of the vagina is patent), is chiefly undertaken with a view to finding out the extent of the atresia and the condition of the uterus and ovaries, so that proper treatment may be adopted. In carrying out this investigation it will be well to give the patient chloroform. The line of treatment will be largely decided by



the extent and position of the atresia, by the state of the internal genital organs, by the presence or absence of retained blood, and by the circumstances of the patient. In the cases in which there is well-marked vaginal atresia with absence of the uterus, but with the presence of functionally active ovaries, as shown by recurring severe pelvic pain, the operation of oophorectomy has been recommended and successfully carried out in several instances. When, on the other hand, there is a more or less normal uterus, associated with hæmatocolpos, entirely different operative interference is indicated. It is not wise to leave the blood-accumulation to nature; for rupture of the sac, even when it occurs through the vagina, is seldom safe in its immediate or satisfactory in its ultimate results. An incision ought to be made into the sac and the contents evacuated under strict antiseptic precautions. If the atresia be slight, and situated low down in the canal, the evacuation may be easily and safely carried out; but if a large part of the vagina be atresic, difficulties and dangers are met with. Dissection must be carefully performed with a sound in the bladder and a finger in the rectum as guides; and the handle of the knife should be freely used in order to avoid wounding neighbouring organs. When the dissection has nearly reached the blood-sac, as determined by rectal touch, a trocar should be introduced to evacuate the fluid, and then the cavity should be laid freely open, washed out with antiseptic lotion, and plugged with iodoform gauze. If it be found that the accumulation of blood is in the interior of the uterus, then the same method of procedure must be followed, with even closer attention to antiseptics. Puncture through the bladder or rectum is not an operation to be recommended.

When in a married woman there is vaginal atresia, but no hæmatocolpos or hæmatometra, operative interference need not be urged unless the patient herself anxiously desires it. Then the question of the advisability of trying to create an artificial vagina will arise. It has been suggested that the urethra should be dilated to allow of coitus; but the proposal has not been received with favour, and it would have been surprising if it had. The creation of an artificial vagina between the bladder and rectum is a difficult operation, requiring a great deal of careful dissection; and it is followed in many cases by disappointing results. If it be attempted, an H-shaped incision should be made in the vulvar region, and then, by means of the finger rather than the knife, a cavity of sufficient depth should be formed; this cavity must next be lined by mucous membrane and skin taken from neighbouring parts and sutured into position; it must then be stuffed with iodoform gauze, and kept open afterwards by a wooden cone-shaped pessary. At a later period the canal is kept open by coitus. A slower method of forming the vagina is by means of electrolysis, and Le Fort has reported a successful case treated in this manner. Of course it must be borne in mind, that as the uterus is either absent or rudimentary, which is demonstrated by the absence of a blood accumulation, the operation is undertaken solely to allow the patient to perform her part in the act of coitus. This being

the case, it is no matter for wonder that certain gynæcologists have not favoured any operative interference in such cases.

**Atresia Vaginæ Lateralis.** — *Pathology.* — It has been already noted under the head of Septate Vagina that one of the canals may be imperforate at its vulvar end, whilst one of the uterine orifices opens into it above. In this way a lateral vaginal pouch or sac is formed, *atresia vaginæ lateralis*. Menstrual blood may collect in the sac and distend it, giving rise to the condition known as lateral hæmatocolpos; suppuration may also occur in it — lateral pyocolpos. The half uterus with which it communicates may likewise be distended with blood or pus (*lateral hæmatometra* or *pyometra*). This vaginal anomaly is nearly always situated on the right side (Puech).

*Clinical Features.* — As in other vaginal anomalies, symptoms do not arise till after puberty, when the gradual dilatation of the lateral vaginal sac gives rise to dysmenorrhœa, pain in the back, dysuria, and pain on defæcation. Vaginal examination reveals an elastic tumour on one side, which may be confounded with pelvic hæmatocele; but may usually be distinguished by its position and gradual increase in size. Rupture may spontaneously occur, either of the vaginal or uterine septum, and dark syrupy blood or pus be discharged. This is usually followed by re-accumulation in the sac, by an increase in the severity of the symptoms and possibly the supervention of pelvic peritonitis and even of death. The *treatment*, therefore, ought to be free incision, washing out of the sac with an antiseptic solution, and in many cases excision of the sac wall.

Winckel has pointed out that inversions or prolongations of the vaginal mucous membrane may be met with, and may extend into the muscular layers of the wall and even into the paravaginal cellular tissue. These pockets have thin, smooth walls, may be from 1 to 1½ inch in length, and must not be confounded with lateral vaginal atresia.

**Stenosis Vaginæ.** — *Pathology.* — The vaginal canal may be abnormally or unusually narrow. The association of this anomaly with the uterus unicornis, and with atresia vaginæ lateralis, has been referred to; but it may also occur in connection with the uterus fœtalis, or even with a normal organ. The stenosis may affect the whole vaginal canal, or may be present at certain points only. In the latter case it is probably due to adhesive colpitis occurring in fœtal life or in the young infant. The narrowing may be circular, diagonal, or in spiral ridges. The so-called supplementary hymen is probably of this nature. The condition is closely allied to if not identical with transverse complete or perforated diaphragms in the vagina.

*Clinical Features.* — If the stenosis be slight it may give rise to no inconvenience; for coitus, or labour if coitus fail, usually serves to dilate the canal completely. In more severe cases it may be necessary to resort to artificial dilatation, incision, or even excision of the constricting bands. Hæmatocolpos is seldom, if ever, a result of vaginal stenosis if the diaphragm be complete. Rupture of the canal may, however, occur in labour unless the obstruction is incised.

**ABNORMAL COMMUNICATIONS OF THE VAGINA.**—The vagina may open into the rectum through an imperfect development of the recto-vaginal septum, which normally intervenes between the two canals. Further, the canal may communicate by a small orifice with the urethra. Most of the cases of abnormal communication of the vagina with the rectum, urethra, and bladder are not really vaginal, but vulvar anomalies; being true instances of persistence of the cloaca of embryonic life, or of the sinus urogenitalis. They will be described amongst the malformations of the vulva. Very rarely, however, cases of congenital ano-vaginal and vagino-urethral fistula have been described. In these instances the anus and rectum and the urethra are normally formed, and the Müllerian vagina is present at the level of the fistulous communications. In these cases the vagina may be septate. Caradec reported an example of this anomaly in which there was a communication between the rectum and vagina, the anus and rectum being normal; and Fordyce recently described a new-born infant with foetal peritonitis, in which each of the two halves of a double vagina opened by a small aperture into the urethra. In the latter case both vaginal canals were atresic inferiorly.

**MALFORMATIONS OF THE VULVA.**—In considering the malformations of the ovaries, tubes, uterus, and vagina, it has been found most convenient to discuss first the anomalies of these organs separately, and then to refer to those combinations of the anomalies which are most commonly met with. Thus unilateral absence of the Fallopian tube was first described separately, and it was pointed out later that it was usually associated with a uterus unicornis and a unilateral vagina. In dealing with the malformations of the vulva, however, this plan is not so useful, for now we have to do rather with groups of anomalies than with single ones. Thus, whilst something must be said regarding abnormalities of the clitoris, labia, and hymen, our main attention will be turned to such associations of defects as are found in the cloacal conditions, and in the cases of so-called hermaphroditism.

**Double Vulva.**—The anomaly to which the name double vulva may be correctly applied is a very rare one. In the case of Katharine Kaufmann, already referred to under the head of "double vagina," there were two well-marked vulvæ separated by a raphé. There were on each side two labia majora and minora, a clitoris, hymen, urethra, and anus. More recently Chiarleoni has reported a less well-marked case in a living infant, thirty-three months old. In this child there were also two vulvar apertures, of which the left lay somewhat obliquely; but the anus was imperforate, and the condition of the internal organs was not ascertained. The cases of Blanche Dumas and of Mrs. B. (reported by Wells) might be cited as examples of double vulva; but in them there were supernumerary lower limbs.

**Defectus Vulvæ.**—Complete absence of the vulva (*defectus* or *atresia vulvæ*) is an anomaly met with only in non-viable fœtuses, chiefly of the acephalic and syndiphal types. The skin passes without any irregularity

or solution of continuity from the symphysis pubis to the coccyx. In such a case the anus is absent; but this is not constant, for in some instances an anal orifice has been found. Internally the rectum, bladder, and genital ducts may all open into one cavity — *persistence of the cloaca*; in other cases the recto-vaginal septum has developed, but the bladder and genital ducts have a common termination — *persistence of the sinus urogenitalis*. During foetal life an accumulation of urine in the bladder and genital canals takes place, and the infant shows at the time of birth considerable abdominal distension from this cause. Cases of so-called

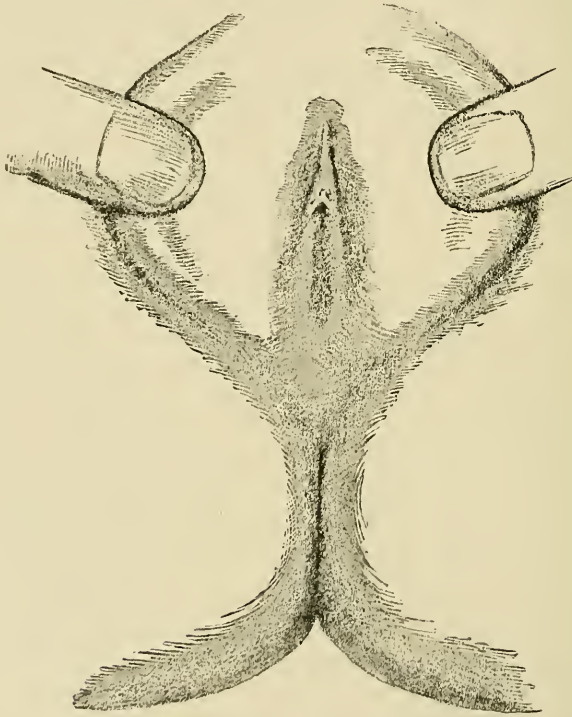

FIG. 37. — Atresia vulvæ superficialis. (After Rauschnig.)

absence of the vulva in the adult woman are probably instances of the anomaly next to be described, *atresia vulvæ superficialis*. Defectus vulvæ in the strict sense of the term has no clinical importance.

**Atresia Vulvæ Superficialis.** — *Pathology.* — The term superficial vulvar atresia may be applied to those cases in which, on account of adhesion of the labia majora or minora, there is an apparent absence of the vulvar cleft (Fig. 37). Usually the occlusion is not complete, for a small orifice is commonly found near the root of the clitoris through which the menstrual fluid and urine escape. The anomaly may be present at birth, or may be



developed in infancy. In both cases it is doubtless due to adhesive vulvitis which leads to a glueing together of the labia.

*Clinical Features.*—In early life there may be difficulty in micturition. After puberty the escape of the menstrual flow may be impeded, but hæmatocolpos does not usually result. After marriage the labial adhesion will prevent coitus, but not necessarily impregnation. It is possible on a superficial examination that the condition may be mistaken for atresia vulvæ. It is usually easy to separate the labia by traction; but if this fail, a sound should be passed in through the anterior opening and a careful dissection made down to it. Attempts at coitus may be sufficient to break down the adhesion.

**Vulva Infantilis.**—In the adult the vulva may have preserved its infantile type and characters. This anomaly is usually associated with defective development of the uterus and ovaries, and with such systemic disorders as chlorosis. Its clinical importance is small compared with that of the associated defects; but the existence of an infantile vulva may have some value as an indication of imperfect development of the internal genital organs.

**ABNORMAL COMMUNICATIONS OF THE VULVA.**—It will be remembered that during development there is a time when the allantois (bladder), Müllerian ducts (vagina), and rectum all open into a common cavity, which in its turn opens on the surface of the body, and is called the cloaca. Normally this condition is transitory; but in certain cases it is permanent, and thus the anomaly known as *atresia ani vaginalis* or *vulvar anus* is produced. In other cases development has advanced a stage further before it is arrested; the perineal partition has grown downwards and separated the rectum, which now opens externally at the anus, from the rest of the cloacal cavity, which is now known as the *urogenital sinus*. The persistence of the urogenital sinus, into which bladder and genital ducts open, gives rise to the anomaly known as *hypospadias* in the woman. Female epispadias, a somewhat puzzling and very rare malformation, may also be described here.

**Atresia Ani Vaginalis (Anus Vulvalis).**—*Pathology.*—The term "*persistent cloaca*" ought, perhaps, to be given to this anomaly rather than the cumbersome and not strictly accurate expression "*atresia ani vaginalis.*" "*Anus vulvalis,*" "*anus vaginalis,*" and "*anus vulvo vaginalis,*" are also names which have been applied to this malformation. Apparently the normal anus is absent, and the rectum opens into the vagina or the vulva (Fig. 38). Strictly, however, by imperfect down-growth of the perineal partition, the rectum opens not into the vagina or vulva, but into the urogenital sinus. The Müllerian ducts have not yet grown downwards to form the lower part of the vagina. What is commonly regarded as vagina is, therefore, not truly so, but is the canal or sinus which precedes the development of the vagina. In the communication of the rectum with this sinus there is, therefore, a persistence of the cloacal stage.

*Clinical Features.* — The chief symptom of this anomaly is the passage of the fæces through an opening either in the neighbourhood of the vestibule or in that of the posterior commissure. In some instances, when there is a sphincter, the patient has control over the fæces; but in other cases there is no such control. In the latter case the external genitals, which are kept constantly moist, are apt to be sore. So uncomfortable is the patient thus rendered, that she gets into the habit of inducing constipation to render the emptying the bowels a weekly instead of a daily act. When there is control over defæcation there is not any pressing need for operative interference; but the sinus urogenitalis ought to be douched after each motion. When, on the other hand, there is fæcal incontinence it will be necessary to operate, and the age when

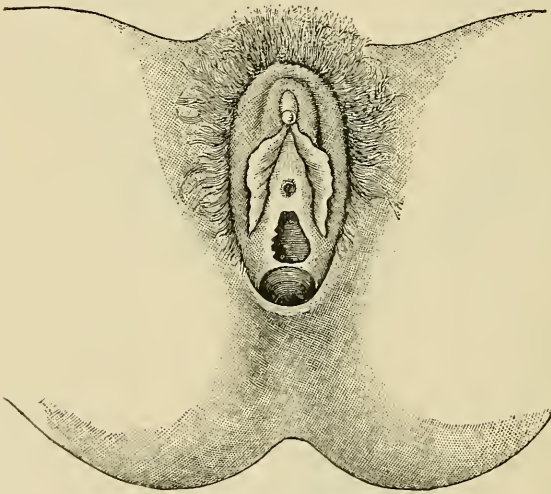

FIG. 38. — Anus vulvalis. (After Dwight.)

interference is most likely to be successful is that of fifteen years or later, when the fæces are fully formed and the tissues can be more easily moulded. The usual operation consists in the passage of a probe through the fistula, and the bringing of it out in the position where the anal aperture ought to be. The parts between the probe and the skin surface are then to be divided, and the rectum pulled down and sutured into position. As, however, by this means a permanent cure can very rarely be obtained, Buckmaster has recently advocated a modification of the operation. He advises that the probe should be brought out, not in the position where the anus should be, but in front of it, just above the levator ani muscle. Then the tissues above the probe are to be divided, and the rectum drawn to the skin and fastened there, but without strain. The raw surfaces must then be sewed together. At a

later period the fibres of the levator ani are to be split, as are those of the rectus muscle in gastrostomy, in order to get a good sphincter. It remains to be seen whether this method of operation will yield more satisfactory results than the older one.

**Persistent Urogenital Sinus (Hypospadias in Woman).** — *Pathology.* — In one sense it is incorrect to speak of hypospadias in the woman as an anomaly, for the normal woman, as regards her external genitals, may be called a hypospadiac man. There is, however, a malformation of the female genitals to which this name has been commonly given. Properly speaking, it is a persistence of the urogenital sinus; the urethra appears to open into the vagina; but what is regarded as vagina is really sinus urogenitalis. Through a common opening at the base of the clitoris, which, it may be remarked, often shows hypertrophy, both the urine and the menstrual fluid escape. The perineum is normally formed, and the rectum opens separately behind it at the anus. Thus the condition differs from the persistent cloaca of atresia ani vaginalis. Pozzi describes two varieties, differing in degree, of hypospadias in the female subject. In one, which represents the minor degree, the vestibular canal is long and narrow, and receives the opening of the urethra and vagina fairly high up. Very frequently this type is accompanied by a hypertrophy of the clitoris, and thus a condition of parts is produced which may give rise to some doubt as to the sex of the individual. In the second degree, which may be called hypospadias proper, the urogenital canal has disappeared; but the lower part of the allantois, which ought to have been changed into the urethral canal, has been included in the formation of the bladder. There is thus absence of the urethra, and the vagina and bladder open together into the vestibular canal; so that it appears as if the bladder opened directly into the vagina. Cases of this kind have recently been reported by Strong and Frank. There will be incontinence of urine as a symptom.

**Epispadias in Woman.** — *Pathology.* — Epispadias, as a defect of the upper wall of the urethra is called, may occur alone, or it may be associated with malformations of the bladder and anterior abdominal wall. In the former case the urethra is seen as an open groove passing upwards in the position of the vestibule, and disappearing under the symphysis pubis, to end directly either in the bladder, or in the upper and closed part of the urethra; for the defect may be present only in part of the canal. On each side of it lies one-half of the split clitoris, and attached to each half is the upper end of one labium minus. The labia majora may unite normally in front or may diverge. The bladder is closed in anteriorly, and there is usually no separation of the symphysis pubis; it is, however, broader than normal. The growth of hair in the median line of the mons veneris may be defective, as in a case of female epispadias seen by myself. The bladder cavity is commonly diminished in size. In the other form of epispadias the anomaly is complicated by ectopia vesicæ (extroversion of the bladder) and by a failure of union of the arcus ossium pubis. In this case the

upper ends of the labia majora are wide apart, and the urine escapes directly from the ureters. Sometimes it is not the bladder which is thus open to the front, but the cloaca — development not having proceeded so far as to form a separate bladder. Intermediate types may be found between those two varieties, the simple and the complicated; and these serve as connecting links. It is with the first variety, however, that we have here specially to do. Epispadias is much rarer in the female than the male subject — a circumstance which has not yet found a satisfactory explanation. Whether the anomaly be due to the rupture of parts already fused together, or to the failure of union of structures which normally grow together, has not yet been definitely settled. Durand seems to connect it with an imperfect formation of what Tourneux terms the “bouchon cloacal.”

*Clinical Features.* — The most important clinical manifestation of uncomplicated epispadias is incontinence of urine. The incontinence is not usually complete; but any sudden movement or change in position is followed by a gush of urine from the small bladder. As a result the external genitals are kept constantly wet, erosions soon appear upon them, and the condition of the patient is most distressing. Menstruation, however, commonly occurs normally, and the woman may become pregnant and bear a child. The cure of the condition is, therefore, urgently called for, and by paring the edges of the parts, and uniting them by sutures, a good result is sometimes obtained. In many instances, however, the operation fails for want of sufficient tissue, or on account of breaking down of the union artificially brought about. In such cases we have to fall back upon the use of a carefully fitted urinal, by means of which the patient's condition is rendered bearable. This was all that could be done for the case seen by me.

**MALFORMATIONS OF THE CLITORIS AND LABIA.** — *Pathology.* — It has been shown in the preceding pages how the vulva may be malformed in all its component parts; but it must now be added that each of the external genital organs may alone be the subject of an anomaly. The clitoris, for example, may be entirely wanting. This happens sometimes in connection with epispadias; but it is then more usual to find it bifid. Possibly split clitoris in the female is homologous with the rare cases of bifid or double penis in the male subject. In some cases the clitoris is found to be poorly developed, but it is more common to observe hypertrophy of it. This enlargement is doubtless more often acquired than congenital, and is then associated with self-abuse; but it may also be present at birth, usually in association with persistence of the urogenital sinus, or with uterine malformations. When hypertrophy of the clitoris is also combined with labial hernia of the ovaries, the resemblance which the individual bears to the male type is very marked.

The labia majora may be absent, but this defect is nearly always associated with ectopia vesicæ.



They may also be adherent to each other, as has been already pointed out under the head of *atresia vulvæ superficialis*, or *conglutinatio labiorum*. The *labia minora* may also be glued together, and probably this accounts for some of the cases in which they were said to be wanting; they may be truly absent, nevertheless, in connection with *epispadias*. It has been stated that they may be increased in number, two or three folds having been found in place of one; it is quite certain that they may be increased in size, and the deformity called the "Hottentot apron" is well known.

*Clinical Features.* — Enlargement of the clitoris and labia gives rise to irritation in the neighbourhood of the external genitals, and may thus be the cause of self-abuse and of nervous troubles. On this account it may be necessary to amputate the clitoris, or to excise the nymphæ. In a case of my own great benefit followed the excision of the *labia minora* in a highly neurotic girl, who was thus restored from a state of chronic invalidism to one of health and usefulness.

**MALFORMATIONS OF THE HYMEN.** — Many of the malformations of the hymen have little clinical importance, although they are all of interest from the pathological standpoint, and some of them have a bearing upon medico-legal questions. There is as yet no general acceptance of any one theory of the mode of development of the hymen; some writers assert that it is vaginal, others that it is vulvar in origin; but as it may be present when the vagina is absent, and may even be found in *hypospadiac* males, the facts are strongly in favour of the latter theory. Indeed, Pozzi, by whom these facts have been prominently enunciated, regards them as conclusive. At any rate, the hymen is to be looked upon, not as a "fixed" organ, but as a developmental remnant; and it shows, therefore, a very large number of small anomalies as regards structure, form, and position. It consists really of three parts, which Pozzi has named *hymen proper*, *pad of the meatus urinarius* or *urethral hymen*, and *male bridle of the vestibule*. All these parts I have repeatedly been able to recognise in the new-born infant; although in the adult they are not very distinct. It would seem that the urethral hymen, like the hymen proper, may present abnormalities; and in an infant at birth I have seen an occlusion of the *meatus urinarius*, by what I regarded as a fusion of the two lateral parts of the pad of the *meatus*, or *hymen urethræ*.

**Double Hymen.** — The cases of double hymen which have been reported are probably errors of interpretation. What is called a supplementary hymen is usually a perforated diaphragm in the vagina a little above the level of the normal hymen. Two or even three of these diaphragms may exist, and they are doubtless due to adhesions formed between the vaginal walls in foetal life. Of course in the rare cases of double vulva there may be two hymens, but this is not what is usually meant by "double hymen."

**Absence of the Hymen.** — Absence, like duplication of the hymen, is

an anomaly whose occurrence is not well established. In the infant at birth the membrane often consists of two pointing lateral folds which may easily be mistaken for the labia minora; and in this way the notion arises that the hymen is absent. Further, in certain cases, especially in the negro race, the hymen is situated deeply, because the vestibular canal is longer than normal; and here again the membrane may seem to be wanting. The medico-legal bearing of these facts in connection with the question of rape is evident.

**Atresia Hymenalis.** — *Pathology.* — The occurrence of imperforation of the hymeneal membrane is probably not nearly so common as the large number of reported cases would seem to show. Undoubtedly genuine examples of atresia of the hymen are occasionally met with; but in the majority of the recorded cases there is evidence to lead us to suspect that the membrane supposed to be hymeneal was really the blind end of the Müllerian vagina. It is often possible, as Matthews Duncan and others have shown, to find the normally perforate hymen pushed backwards and hidden to some extent by the bulging of the vaginal sac. Strictly speaking, cases of hymeneal atresia are often instances of atresia of the lower part of the vagina; or, as some prefer to name it, of the *retro-hymen*. In another group of cases adhesion of the labia minora gives rise to an appearance resembling atresia of the hymen; and it is only when the labial attachment has been divided that the hymen is seen lying beneath. The pathological results of all these conditions are the same: there is retention of vaginal mucus in infancy, and of menstrual fluid in later life, with consequent occurrence of hæmatocolpos.

*Clinical Features.* — In the position of the vaginal orifice is found a bulging membrane, sometimes of a bluish colour, which in some degree resembles the intact bag of membranes in a labour case, and has even been mistaken for it. This swelling has gradually increased from the time of puberty, and its appearance has been accompanied by colicky pains recurring with increasing severity at intervals of a month, and by the absence of the menstrual discharge. Sometimes, also, the evacuation of the bladder and bowels has been rendered difficult and painful; and in a few instances there have been vicarious menstrual hæmorrhages. In advanced cases a fluctuating abdominal tumour has appeared, the result of distension of the vagina with blood. On the top of this swelling a small hard mass can sometimes be detected; this is the undistended uterus. In other cases this organ also has become a blood-sac, and in such cases hæmatocolpos and hæmatometra coexist.

Operative interference is always required in these cases, for spontaneous external rupture is uncommon; even when it occurs it is unsatisfactory, the evacuation being incomplete, and often followed by suppuration in the vaginal cavity. It used to be the custom to puncture the imperforate hymen at one sitting, and then later to make a crucial incision, and fully evacuate the contents; for it was thought that the sudden escape of the vaginal contents might be attended by dangerous results. But this method is apt to be followed by suppuration; and it is

best to make first a small incision so as to allow the blood slowly to escape, and then at the same sitting to enlarge the opening, to wash out the canal thoroughly with an antiseptic lotion, and finally to pack it firmly with iodoform gauze.

**Anomalies in the form of the Hymen.** — Many anomalies in the form of the hymen may be met with, but they are of comparatively little practical importance. Instead of having its normal crescentic or semilunar shape, it may retain its infantile character; it then shows two lateral projecting lips, which have sometimes been mistaken for the nymphæ; it is then called *labiated* or *infundibuliform*. Sometimes notches occur naturally in the membrane, which then is called the *hymen denticulatus*; it is necessary to remember the occurrence of these folds or notches, and to distinguish them from the rents produced by coitus or labour. Rarely the *fimbriated hymen* is met with. The orifice is usually situated nearer to the anterior than to the posterior border of the membrane; but occasionally it is quite central — *hymen circularis*. Further, the opening may be very large (*fulciform*), or there may be two orifices of equal size, situated laterally (*hymen septus*). Yet another form is that in which there are two apertures of unequal size, and situated irregularly (*hymen bifenestratus*, *hymen biforis*). A very uncommon type is the *cribriform*, in which there are many small holes in the membrane (*hymen cribriformis*).

**Anomalies in the structure of the Hymen.** — *Pathology.* — The hymen may be abnormally thick, abnormally firm or rigid, or abnormally vascular. It may also show combinations of these anomalies. Thus it may be both thick and vascular, or both rigid and fleshy. To a certain extent these states may be regarded as due to a persistence of the foetal characters of the membrane, and they are of some clinical importance.

*Clinical Features.* — Abnormal rigidity of the hymen may be the cause of dyspareunia, or it may entirely prevent penetration in the act of coitus. In a case seen by myself it was found necessary to excise the hymen of a newly married patient before complete connection could be accomplished by her husband. In other cases pregnancy occurs notwithstanding the unruptured state of the hymen; and the presence of the membrane may protract labour, or, if it be torn, may cause a deep laceration also of the perineum. Cases have even been reported in which the hymen has been found intact after a miscarriage; but in these instances the membrane has probably been abnormally elastic, rather than abnormally rigid. The importance of the occurrence from the medical jurist's standpoint is manifest in connection with the question of chastity. Abnormal vascularity of the membrane is also an anomaly of some importance, for, on the first occasion of coitus, it may be the cause of alarming or indeed of dangerous hæmorrhage. All these structural malformations of the hymen are more easily understood if it be granted, as Pozzi affirms, that the hymen is the homologue of the corpus spongiosum of the male.

## HERMAPHRODITISM

The exact meaning of the word "hermaphrodite," as applied to the human subject, has undergone a change. Whilst the older writers applied the term to individuals whom they regarded as possessing the organs of both sexes in an anatomical and in a physiological sense, modern authors have come to use the name rather to indicate subjects whose true sex is doubtful. Malformations of the genital organs, giving rise to doubts as to the true sex of the individual, have attracted the attention of observers from the earliest periods of the world's history, and, as I have elsewhere shown (327), records of such cases have been found on the brick tablets of the ancient Chaldean libraries. In Rome individuals of doubtful sex were destroyed. In the East, on the other hand, there is reason to believe that they were deified. According to the Talmud, Abraham was a hermaphrodite, and so, according to many authors, was Adam.

In one sense the human embryo at a certain period of its existence may be regarded as hermaphrodite. There is a stage in development when it is impossible to state whether the sexual gland will become an ovary or a testicle; whether the Müllerian or the Wolffian ducts will atrophy; whether the genital tubercle will become a penis or a clitoris. The embryo is then, so far as is known, potentially of either sex, and awaits the action of some force to determine which sex is to predominate. It is easy to understand how morbid influences, brought to bear upon the embryo at or about the time when it is passing from its sexually indifferent stage into one of differentiation, may so upset the normal process of development as to produce an individual with, for example, testicles and a uterus. It is, however, a matter of great difficulty to imagine a condition of affairs which would give rise to the presence of a testicle and an ovary on the same side; for, so far as is known, the sexual gland may become either a testicle or an ovary, but not both. In the Müllerian and Wolffian ducts, on the other hand, we have to do with two sets of structures, one of which normally atrophies and the other develops; but abnormally both may persist in a more or less fully formed condition. As a matter of fact, it is very doubtful whether a genuine case of the coexistence of testicles and ovaries in the human subject has ever been reported; whilst instances of pseudo-hermaphroditism, as they have been called, are far from rare. Still, it is never safe to say that the occurrence of any particular teratological combination is impossible; and if we bear in mind that true hermaphroditism has been met with in fish, amphibians, and even in the goat and pig, it may be that some observer will yet record an undoubted case in the human subject.

Writers have classified cases of hermaphroditism in various ways. Klebs, for example, divides them into two groups: true hermaphroditism, or *hermaphroditismus verus*, in which ovaries and testicles coexist; and pseudo-hermaphroditism, or *hermaphroditismus spurius*, in which, along



with either ovaries or testicles, there are found some of the genital organs of the opposite sex. Pseudo-hermaphroditism, again, he divides into masculine or feminine, according as testicles or ovaries are present; whatever may be the state of the other reproductive organs. Pozzi to some extent modifies this scheme of classification. He arranges all the cases in three groups: *partial pseudo-hermaphroditism*, in which one sex obviously predominates, only a few of the peculiarities of the other being present; *pseudo-hermaphroditism properly so-called*, including a large number of cases chiefly of the variety known as male hypospadiacs; and *supposed true hermaphroditism*, in which both kinds of sexual glands have been regarded as present. It does not seem theoretically necessary to make a distinction between pseudo-hermaphroditism and the partial variety, although practically the separation may be of value. The scheme here adopted is that which groups all the cases into pseudo-hermaphrodites and supposed true hermaphrodites, with certain subdivisions which will be stated under each head; and I have added a new variety, or rather have resuscitated an old one, in which the external genitals of both sexes seem to be present in the same individual. Something will first be said regarding the cases which have been reported as instances of true hermaphroditism, and then the large group of the pseudo-hermaphrodites will be considered.

**SUPPOSED TRUE HERMAPHRODITISM.**—Klebs has divided true hermaphroditism into three groups: *bilateral* (or *vertical*), in which an ovary and a testicle are found on both sides of the body; *unilateral*, in which an ovary and a testicle coexist on one side, whilst on the other side is an ovary or a testicle, or neither; and *lateral* (or *alternate*), in which the female gland is present on one side and the male on the other. In the present state of our knowledge this subdivision is, as regards the human subject at any rate, quite unnecessary; for well-authenticated examples of the first and second varieties are wanting, and even of the third type the instances that have been reported are not altogether convincing. All the cases in which there is no report of a post-mortem examination are, of course, useless in classification; for the whole value of such reports consists in the recognition by the naked eye and microscopically of two glands, one of which must have the characters of the ovary and the other those of the testicle. It cannot even be safely asserted, as was done by Rokitansky in the case of Catherine Hoffmann, that the allegation of a menstrual discharge is a proof of the existence of ovaries. Indeed there is evidence to show that the adult subjects of these abnormalities will intentionally mislead the observer concerning such phenomena as menstruation.

The case reported in 1870 by C. L. Heppner of St. Petersburg has been regarded by many authors as a genuine example of hermaphroditismus verus bilateralis; for in it were described a uterus with ovaries and tubes, and on each side also a rounded body in the neighbourhood of the ovary which had the microscopical characters of the testicle. The external organs were like those of the woman. Now, with regard

to this case, it must be borne in mind that the parts had been preserved for some time in spirit before they were examined; and that the microscopical appearances of the so-called testicles might easily be regarded as those of immature or undifferentiated ovaries. The arrangement of tubes packed with cells, as depicted by Heppner, seems to me to suggest a mal-developed ovary as much as a testicle. The probability is that the so-called testicles were really accessory or constricted ovaries—bodies which, as has already been stated, often show a structure made up almost entirely of Pflüger's tubes. The case examined by H. Meyer, and reported by Cramer in 1857, is one of a considerable number in which true hermaphroditism of the lateral variety was alleged to be present. In this instance there were a rudimentary uterus and a vagina, and, on the right side, a normal ovary, parovarium, and tube. On the left side were a tube, a parovarium, and a body herniated in the left scrotal sac, and supposed to be a testicle. Cramer does not give the detailed microscopical appearances of this body; but it seems more rational to regard it as an ovary, possibly in a rudimentary state, which had descended into the left labium, than as a testicle. In conclusion, it may be said that science still awaits the publication of a case in which all competent observers will be able to recognise the existence in the same individual of two glands, one of which is undoubtedly ovarian and the other testicular in nature. In the meantime it seems impossible to conceive how the impulse that determines sex can be so divided in its action as to turn one sexual gland into an ovary and the other into a testicle.

**PSEUDO-HERMAPHRODITISM.**—*Pathology.*—Cases of pseudo-hermaphroditism are not uncommon, as a glance at the appended bibliographical list (for the last five years) will serve to show. In many of them the dubiety as regards sex is evidently due to the existence of one or other of the anomalies of the female external genital organs which have been already described. In many more, however, we have to deal with malformations of the penis and scrotum, which have given to the external parts a somewhat feminine appearance. In the former group of cases the ovaries are present, whatever may be the condition of the other organs, and the individual is therefore really a female in the state known as *pseudo-hermaphroditismus femininus* or *gynandry*: in the latter group the subject by the possession of the testicles is a male, however closely he may approach the other sex in appearance, a state known as *pseudo-hermaphroditismus masculinus* or *androgyne*. Individuals of the second kind are far commoner than those of the first. Each of these two varieties has been subdivided into three groups—*internus*, *externus*, and *completus*. Thus in a case of pseudo-hermaphroditismus masculinus internus there are testicles in association with external genitals of the male type, and a uterus, vagina, and even tubes. In pseudo-hermaphroditismus masculinus externus there are also testicles, but the external genitals and the build of the body are feminine.

Again, in pseudo-hermaphroditismus masculinus completus seu externus et internus there are testicles, but there is also a uterus masculinus with tubes; and the external organs approach more or less closely to the female form. In the same way in the three varieties of feminine pseudo-hermaphroditism there are always ovaries; but in the internal type there are also distinct traces of the Wolffian ducts; in the external type the external genitals are of the male form; and in the complete type the external organs are masculine, and the Wolffian ducts and prostate gland are present. The enumeration of these varieties will have given the reader some idea of the morbid anatomy of pseudo-hermaphroditism; at the same time it must be borne in mind that some of them are very rare; one of them, on the other hand — pseudo-hermaphroditismus masculinus externus — is, comparatively speaking, very common.

One of the most usual arrangements of parts to which the name of feminine pseudo-hermaphroditism is given is that in which a woman presents an adhesion of the labia along with hypertrophy of the clitoris. When, also, there is a labial ovarian hernia on one or both sides, and a development of hair on the face, the resemblance to the male, at any rate to the hypospadiac male, becomes very striking. The vulva, however, may be normal, and the subject show simply an enlarged clitoris, a beard, and a masculine arrangement of the pubic hair, as in the case of Zefthe Akaira (*La Donna-Uomo*), recently described by Zucarelli in Italy. Examples of this kind of gynandry might be multiplied.

Non-descent of the testicles in the male gives origin to one variety of androgyny. Such men are often the subjects of gynæcomastia (enlargement of the breasts); and since also the penis, although perforate, is sometimes small, and the sexual functions poorly developed (infantilism), it is easy to understand how doubts as to their virility may arise. A more common type of androgyny, however, is that caused by the existence of scrotal hypospadias (Fig. 39). In this case the resemblance to the female type of external genitals is very strong, for there is a small imperforate penis often fixed in position under the symphysis by adhesions; the urethra opens externally near the root of the penis, and below it is a sort of vulvar aperture or vestibular canal which may even be of some depth, and may be guarded by a hymen. The external genitals in such a case resemble, as Pozzi graphically expresses it, those of an embryo seen under a magnifying glass. When it is also borne in mind that the testicles are either undescended or at any rate atrophic, and that the individual has probably been mistaken for and brought up as a girl, and has thus acquired feminine habits, it is easy to see how extremely difficult it may be to ascertain the real sex. The difficulty may be still further increased by enlargement of the mammae, by the absence of hair on the face and chest, and by the occasional discovery of a uterus: although, of course, ovaries are not to be detected. Doubtless most of the cases of supposed true hermaphroditism have been really hypospadiac men.

A word or two may here be said regarding a form of pseudo-hermaphroditism not recognised by recent writers. In very rare instances



individuals otherwise apparently single show complete duplication of the vulva or of the penis. In a recent article (328) I have shown that in some of these cases of diphallus one penis only may be perforate, the other being small, and presenting an opening below it through which urine escapes.

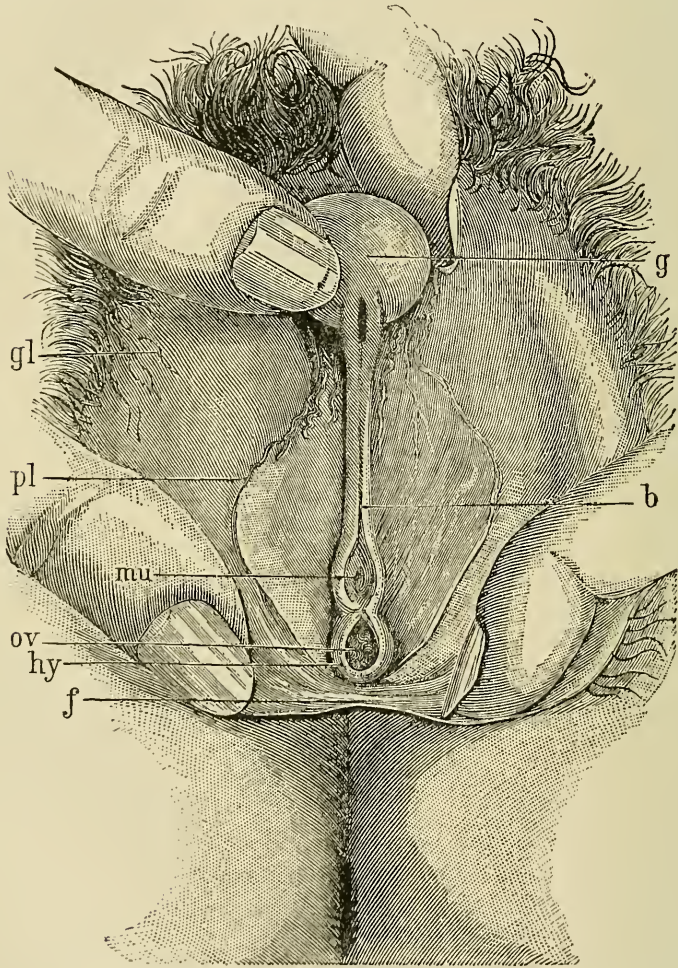

FIG. 39. — Pseudo-hermaphroditism, perineo-serotal hypospadias. (After Pozzi.) *g*, Glans; *b*, frenum; *mu*, meatus urinarius; *ov*, vulvar orifice; *hy*, hymen; *f*, fourchette; *pl*, labia minora; *gl*, labia majora.

Such a case might easily be regarded as an instance of the coexistence of both male and female external genitalia; and possibly some of the discredited accounts of persons provided with a vulva and a penis, reported by early writers, may have belonged to this category. Similarly in



individuals with a double vulva the enlargement of one clitoris might give rise to a similar notion; and probably the case of an infant, seen by Moostakov, in which there were on one side external genitals of the female type with a perforate urethra, and on the other an imperforate penis (?) and a scrotum without testicles, may have been of this kind. The condition might be called *external pseudo-hermaphroditism*, had not this name been already appropriated to another type of genital anomaly.

*Clinical Features.*—Whilst in the histories of pseudo-hermaphrodites there are many details which are peculiar to each case, there are also some which are practically common to all. The error in the recognition of the true sex of the individual is usually made at birth and confirmed at baptism; and, as a rule, it is not till the period of puberty is reached that doubts of the accuracy of the declaration at birth begin to prevail. In the case of male pseudo-hermaphrodites the error may even be perpetuated still longer, and the individual may be married as a woman and live with a husband, an imperfect form of coitus taking place per urethram. Usually, however, suspicions begin to be entertained at puberty when, in the case of hypospadiac males who have been brought up as females, the failure of the establishment of the menstrual function and the appearance of certain of the secondary sexual characters proper to the male sex give rise to doubts. At the same time, it must be borne in mind that even in these subjects hæmorrhage simulating the menses may take place from the urethra dilated by coitus, and in a few instances a real catamenial discharge from a uterus has been noted. Further, the secondary sexual characters cannot be relied upon; for mammary enlargement, rounded outlines, a broad pelvis, a small larynx, and a feminine distribution of the body-hair, may all be met with in male pseudo-hermaphrodites, whilst the secondary sexual characters of the male may coexist with ovaries. The habits, also, and the feelings and desires of the subject, will depend largely on the surroundings of early life, and cannot be regarded as diagnostic of the sex. Pseudo-hermaphrodites are generally sterile; for the sexual glands are often mal-developed, and even when they are active the anomalies of the other organs prevent the successful accomplishment of the reproductive act. Mental and moral weakness and even insanity are not uncommon; and in the case of Alexina B., so graphically recorded by Tardieu, the individual, a hypospadiac male, committed suicide. Many of the so-called "degenerates" show anomalies of the genital organs. That the condition may be hereditarily transmitted is probable; at any rate family prevalence is not uncommon, and J. Phillips has recently reported four cases of pseudo-hermaphroditism in one family and Lindsay has seen three. I am also acquainted with a case in which two hypospadiac males, the children of one mother, have been brought up as sisters.

The treatment of such cases presents many puzzling problems. Lawson Tait's rule that every infant about whose sex there is doubt should be brought up as a male is a good one; for male pseudo-hermaphrodites are more common than female, individuals reared as males are not so apt to enter into marriage in ignorance of their sexual inability, and there is less

danger in bringing up a girl among boys than a boy among girls. The question of the advisability of surgical interference is a difficult one. In a case reported by Christopher Martin, the testicles were removed from an individual brought up as a girl, and castration was followed by a development of the breasts and pubic hair; whilst Péan records the extraordinary operative history of an individual whose abdomen was first opened to discover the sex, then an artificial vagina was made, and finally the abdomen was again opened and the tubes and ovaries removed. The division of a tight frenum in a hypospadiac male, and the separation of the adherent labia in a gynandrous individual, are minor operations which may be undertaken without hesitation; but it is doubtful whether we are justified in removing the sexual glands in any case of pseudo-hermaphroditism, although of course the alternative procedure of making a redeclaration of sex is also attended with difficulty and great inconvenience. Possibly it may be well to consider the advisability of the establishment of a third class of individuals, who shall be regarded as neuter.

The medico-legal bearings of hermaphroditism are self-evident. The questions of identity, of paternity, of the right to exercise the franchise, and to enter professions open only to one sex, when the individual is one about whose true sex there is some doubt, all require very careful consideration and clinical investigation. Further, the legality of a marriage between a man and a hypospadiac male cannot be maintained; and one between a woman and a gynander is equally against the law. Further consideration of these matters is not, however, necessary in a text-book of gynæcology.

J. W. BALLANTYNE.

#### RECENT REFERENCES

**Malformations of the Ovaries:**—1. BALLANTYNE and WILLIAMS. *Structures in the Mesosalpinx*, p. 44, 1893.—2. For early bibliographical references vide OLSHAUSEN. *Die Krankheiten der Ovarien*, p. 12. Stuttgart, 1877.—3. WINCKEL. *Lehrbuch der Frauenkrankheiten*, p. 595. Leipzig, 1886.—4. COLOMIATTI, V. *Frammenti di embriologia patologica*, p. 14. Torino, 1880.—5. KEPPLER. *Allg. Wien. med. Ztg.* p. 385, 1880.—6. HOMANS, J. *Boston M. and S. Journ.* cxvii. p. 50, 1887.—7. SIPPEL, A. *Centralbl. f. Gynäk.* xiii. p. 305, 1889.—8. BASSINI. *Centralbl. f. Gynäk.* xiii. p. 640, 1889.—9. BALLANTYNE, J. W. *Trans. Edin. Obst. Soc.* xv. p. 56, 1890.—10. TAIT, LAWSON. *Diseases of Women*, i. p. 277, 1889.—11. SCHANTZ, H. "Vier Fälle von accessorischen Ovarien," *Diss.* Kiel, 1891.—12. FALK, E. *Berl. klin. Wchschr.* No. 44, 1891.—13. MUNDÉ. *Am. Journ. Obst.* xxiv. p. 218, 1891.—14. SUTTON, J. BLAND. *Surgical Diseases of the Ovaries, etc.*, p. 24. London, 1891.—15. SKENE, A. J. C. *Diseases of Women*, 2nd edit. p. 450, 1892.—16. POPOFF, D. *Arch. f. Gynaek.* xliiv. p. 275, 1893.—17. ZINNIS, A. *La méd. infant.* i. p. 267, 1894.—18. RUFFOLT, E. *Arch. f. Gynaek.* xlvii. p. 646, 1894.—19. DELAGÉNIÈRE, P. *Progr. méd.* 2nd series, ii. p. 256, 1894.—20. EDRIDGE-GREEN, F. W. *Brit. Med. Journ.* p. 416, i. for 1895.—20*a*. ENGSTRÖM. *Finska läkar. handlingar*, xxxvii. p. 667, 1895.—20*b*. McCOSH, A. F. *Trans. Am. Surg. Assoc.* xiii. p. 481, 1895.—20*c*. LOCKWOOD, C. B. *Brit. Med. Journ.* p. 716, ii. for 1895.

**Malformations of the Fallopian Tubes:**—21. RICHARD, A. *Compt. rend. Soc. de biol.* iii. p. 37, 1852.—22. BLOT. *Ibid.* 2nd series, iii. p. 176, 1857.—23. HÜTER, C. *Monats. f. Geburtsk.* xxv. p. 424, 1865.—24. STEWARD, T. G. *Jour. Anat. and Physiol.* ii. p. 243, 1868.—25. KEPPLER. *Allg. Wien. med. Ztg.* p. 385, 1880.—26. COLOMIATTI, V. *Frammenti di embriologia patologica*, p. 14. Torino, 1880.—27.

SINÉTY, L. DE. *Traité pratique de Gynécologie*, p. 770, 1884.—28. WINCKEL, F. *Lehrbuch der Frauenkrankheiten*, p. 569. Leipzig, 1886.—29. DORAN, A. *Trans. Obst. Soc. London*, xxviii. p. 171, 1887.—30. BALLANTYNE, J. W. *Trans. Edin. Obst. Soc.* xv. p. 56, 1890.—31. HAULTAIN, F. W. N. *Trans. Edin. Obst. Soc.* xv. p. 220, 1890.—32. BALLANTYNE, J. W., and WILLIAMS, J. D. *Brit. Med. Journ.* Jan. 17 and 24, 1891.—33. FALK, E. *Berl. klin. Wchnschr.* No. 44, 1891.—34. SUTTON, J. BLAND. *Surgical Diseases of the Ovaries and Fallopian Tubes*, p. 227. London, 1891.—35. HAULTAIN, F. W. N. *Trans. Edin. Obst. Soc.* xvii. p. 194, 1892.—36. AMANN, J. A. *Arch. f. Gynaek.* xlii. p. 133, 1892.—37. POPOFF, D. *Arch. f. Gynaek.* xlv. p. 275, 1893.—38. BALLANTYNE, J. W., and WILLIAMS, J. D. *The Structures in the Mesosalpinx*, p. 25. Edinburgh, 1893.—39. MARCHAND. *Berl. klin. Wchnschr.* p. 814, Aug. 27, 1894.—40. RUPPOLT, E. *Arch. f. Gynaek.* xlvii. p. 616, 1894.—41. KOSSMANN. *Ztschr. f. Geburtsh. u. Gynäk.* xxix. p. 253, 1894.—42. FERRARESI, C. *Ann. di. Ostet.* xvi. p. 521, 1894.—43. DELAGÉNIÈRE, P. *Progrès méd.* 2nd series, ii. p. 256, 1894.—44. SÄNGER, M. *Monatschr. f. Geburtsh. u. Gynäk.* i. p. 21, 1895.—45. EDRIDGE-GREEN, F. W. *Brit. Med. Journ.* p. 416, i. for 1895.—46. KUBE, N. N. *Journ. akush. i jensk. boliez.* p. 485, May 1895.—46a. PENROSE. *Am. Journ. Obst.* xxxii. p. 295, 1895.—46b. SÄNGER. *Centralbl. f. Gynäk.* xx. p. 162, 1896.

Uterus Accessorius:—47. SKENE, A. J. C. *Treatise on the Diseases of Women*, p. 29, 1892.—48. HOLLÄNDER, E. *Berl. klin. Wchnschr.* xxxi. p. 452, 1894.—49. DEPAGE. *Arch. de tocol.* xxi. p. 550, 1894.

Uterus Didelphys et Bicornis:—50. ALTHEN. *Centralbl. f. Gynäk.* xiv. p. 711, 1890.—51. PASCHEN. *Centralbl. f. Gynäk.* xiv. p. 11, 1890.—52. DUDLEY. *Am. J. Obst.* Jan. and Feb. 1890.—53. SCHÜLER, C. "Ueber einen Fall von Uterus duplex septus cum vagina septa." *Diss.* Kiel, 1890.—54. GUSSEROW. *Charité-Ann.* xv. p. 618, 1890.—55. THEVARD. *N. Arch. d'obst. et de gynéc.* v. p. 640, 1890.—56. ELBING, R. *St. Petersb. med. Wchnschr.* vii. p. 299, 1890.—57. VASTEN, V. A. *Bolnitsch. gaz. Botkina.* i. p. 986, 1890.—58. BALLANTYNE, J. W. *Trans. Edin. Obst. Soc.* xv. p. 160, 1890.—59. SCHWARZ. *Frauenarzt*, vi. p. 12, 1891.—60. BROOME, G. W. *Weekly M. Rev.* xxiii. p. 321, 1891.—61. MASSEY, G. B. *Ann. Gynec. and Pædiat.* iv. p. 365, 1890-1.—62. HIRIGOYEN. *Rev. obstét. et gynéc.* vii. p. 133, 1891.—63. CURATULO, G. E. *Riforma med.* vii. p. 337, 1891.—64. CIAJO, A. *Gazz. d. osp.* xii. p. 670, 1891.—65. NITOT. *Rev. obstét. et gynéc.* vii. p. 340, 1891.—66. LAYTON, R. *N. Orl. M. and S. J.* xix. p. 412, 1891-2.—67. SCHWARTZ, F. *Orvosi hetil.* xxxv. p. 294, 1891.—68. BERLIN, F. *Ann. Gynec. and Pædiat.* v. p. 193, 1891-2.—69. HALTER, G. *Wien. med. Presse*, xxxiii. p. 49, 1892.—70. TANNEN, A. *Centralbl. f. Gynäk.* xvi. p. 51, 1892.—71. SACHS, G. *Med. Obozr.* xxxvii. p. 130, 1892.—72. BURKE, W. H. *Brit. Med. Journ.* i. for 1892, p. 1020.—73. WILLIAMS, F. N. *Lancet*, i. for 1892, p. 1185.—74. DRUJININ, I. N. *J. akush. i jensk. boliez.* vi. p. 239, 1892.—75. GIGLIO, G. *Riforma med.* viii. p. 185, 1892.—76. SICHERER, O. v. *Arch. f. Gynaek.* xlii. p. 339, 1892.—77. PICCOLI, G. *Levatrice mod.* i. p. 58, 1892.—78. BORDÈ, L. *Bull. d. sc. med. di Bologna*, iii. p. 206, 1892 (3 cases).—79. STOLL, K. *Ztschr. f. Geb. und Gyn.* xxiv. p. 275, 1892.—80. ROSSA, E. *Wien. klin. Wchnschr.* v. p. 501, 1892.—81. STEWART, W. S. *Ann. Gynec. and Pædiat.* vi. p. 150, 1892-3.—82. CURRIER, A. F. *N. Y. Journ. Gynec. and Obst.* iii. p. 50, 1893.—83. EDEBOHLS, G. M. *N. Y. Journ. Gynec. and Obst.* iii. p. 290, 1893.—84. STRATZ, C. H. *Nederl. Tijdschr. v. Verlosk. en Gynaec.* iv. p. 121, 1893.—85. BIEHL, K. *Mitth. d. Ver. d. Aerzte in Steiermark*, xxx. p. 103, 1893.—86. KLEINWÄCHTER, L. *Zeitschr. f. Geb. u. Gyn.* xxvi. p. 144, 1893.—87. CULLINGWORTH, C. J. *Trans. Am. Gyn. Soc.* xviii. p. 434, 1893.—88. RATCLIFFE, J. R. *Trans. Obst. Soc. Lond.* xxxiv. p. 469, 1893.—89. LEUF, A. H. P. *Med. News*, lxiii. p. 410, 1893.—90. SENFT, A. *Ztschr. f. ärztl. Landpraxis*, ii. p. 313, 1893.—91. JOHNSON, F. W. *Boston M. and S. J.* cxxix. p. 643, 1893.—92. PFANNENSTIEL, J. *Festschrift . . . in Berlin*, p. 330, 1894.—93. LÖHLEIN, H. *Centralbl. f. Gynäk.* xviii. p. 997, 1894.—94. CROSDALE, H. T. *Am. J. Obst.* p. 359, 1894.—95. SEMELEDER, F. *Gac. méd. Mexico*, p. 287, 1894.—96. CALDERINI, G. *Il Policlinico*, p. 92, 1894.—97. BURTON, J. E. *Liverpool Med.-Chir. J.* p. 459, 1894.—98. GOUGET, A. *Bull. Soc. An. de Paris*, p. 24, 1894.—99. ROSSA, E. *Centralbl. f. Gynäk.* xviii. p. 422, 1894.—100. AYERS, E. A. *Am. J. Obst.* p. 104, 1894.—101. EUSTACHE, G. *Ann. di. Ostet.* p. 336, 1894.—102. SCHUHL. *Ann. de Gynec.* p. 248, 1894.—103. WERDER, X. O. *J. Am. M. Assoc.* p. 234, 1894.—104. KINGHORN. *Montreal Med. Journ.* p. 442, 1894.—105. OWEN, R. O. *Virginia Med. Monthly*, p. 926, 1895.—106. SEREJINSKY, G. P.



*Journ. akush.* p. 183, 1894.—107. SIMON, M. *Centrabl. f. Gynäk.* xviii. p. 1313, 1894.—108. BATCHELOR, F. C. *Intercol. Quart. J. Med. and Surg.* i. p. 309, 1895.—109. ARNOLD, E. G. E. *Lancet*, i. for 1895, p. 988.—110. CHAPUIS. *Lyon. méd.* p. 83, 1894.—111. ROSSIER. *Rev. méd. de la Suisse romande*, p. 159, 1895.—112. ROUX, G. *Arch. de tocol.* p. 59, 1895.—113. SWOPE, S. D. *Med. News*, p. 391, 1895.—114. PENROSE, C. B. *Am. Journ. Obst.* p. 915, 1895.—115. MAYGRIER. *Rev. méd.-chir. d. mal. d. femmes*, p. 353, 1895.—115a. MALLETT, G. H. *N. Y. Med. Journ.* lxiii. p. 24, 1895.—115b. METTENHEIMER, C. *Arch. f. Gynäk.* l. p. 221, 1895.—115c. BAER, B. F. *Am. Gyn. and Obst. Journ.* vii. p. 40, 1895.—115d. BRULL, P. *Arch. de Gynecopat. obstet. y pediat.* viii. p. 651, 1895.—115e. TSCHUDY, E. *Arch. f. Gynäk.* xlix. p. 471, 1895.—115f. SPRIGG, W. M. *Am. Journ. Obst.* xxxii. p. 78, 1895.—115g. EUSTACHE, G. *Journ. sc. méd. de Lille*, xviii. p. 313, 1895.—115h. GOULLIQUOD. *Rev. obstét internat. Suppl.* p. 251, 1895.—115i. GRIFFON, V. *Bull. Soc. Anat. de Paris*, 5. s. ix. p. 520, 1895.—115j. MEERDERVOORT, N. J. F. P. *Arch. de tocol.* xxii. p. 721, 1895.—115k. SPIEGELBERG, H. *Arch. f. path. Anat.* cxlii. p. 534, 1895.—115l. GILES, A. *Trans. Obst. Soc. London*, xxxvii. p. 301, 1896.—115m. SWAYNE, W. *Bristol Med.-Chir. Journ.* xiv. p. 101, 1896.

**Uterus Septus:**—116. SCHRAMM, J. *Centrabl. f. Gynäk.* xiv. p. 185, 1890.—117. SHTOL, K. *Otchet. Mar. ginek. otdiel*, p. 47, 1891.—118. SCIALDONI, A. *Gior. internaz. d. sc. méd.* xiii. p. 534, 1891.—119. KLEINSCHMIDT, K. *Univ.-Frauenklin. in München*, p. 129, 1892.—120. FÜCHTENBUCH, H. *Diss.* Strasburg, 1892.—121. DRAKE-BROCKMAN, H. E. *Brit. Med. Journ.* i. for 1893, p. 1220.—122. HALLOWELL, W. E. *North-west. Lancet*, xii. p. 427, 1893.—123. WHEATON, S. W. *Lancet*, ii. for 1893, p. 1562.—124. CHROBAK. *Centrabl. f. Gynäk.* xviii. p. 431, 1894.—125. MERTENS. *Centrabl. f. Gynäk.* xviii. p. 1001, 1894.—126. WERTH, R. *Arch. f. Gynaek.* xlvi. p. 422, 1895.—127. KARRA, D. A. *Universitetskaya izvestiya*, p. 149, 1895.—127a. WALTHER, H. *Ztschr. f. Geburtsh. u. Gynäk.* xxxiii. p. 389, 1895.

**Uterus Unicornis:**—128. FROMMEL. *Münchener med. Wchnschr.* No. 15, 1890.—129. VOLL. *Sitzungsber. d. phys.-med. Gesellsch. zu Würzburg*, pp. 30, 33, 1891.—130. SKENE, A. J. C. *Treatise on the Diseases of Women*, p. 33, 1892.—131. MANGIAGALLI, L. *Atti. d. Assoc. med. Lombarda*, p. 29, 1892.—132. TAPIE. *Midi méd. i.* pp. 85, 97, 1892.—133. GESSNER. *Centrabl. f. Gynäk.* xviii. p. 824, 1894.

**Uterus Deficiens et Rudimentarius:**—134. WERNER, J. *Deutsche med. Wchnschr.* No. 11, 1890.—135. FRANK, K. *Ztschr. f. Geburtsh. u. Gynaek.* xviii. Hft. 2, 1890.—135. ALTMANN. *Centrabl. f. Gynäk.* xiv. p. 103, 1890.—137. LIEBMANN. *Centrabl. f. Gynäk.* xiv. p. 928, 1890.—138. ROSSIGNOL, F. *Thesis.* Paris, 1890.—139. MARCHIONNESCHI, O. *Pisa*, 1890.—140. SWIECICKI, V. *Wien. med. Bl.* xiv. p. 85, 1891.—141. LOVIOT. *Bull. et mém. soc. obst. et gynec. de Paris*, p. 78, 1891.—142. BALADE. *Journ. de méd. de Bordeaux*, xxi. p. 85, 1891-2.—143. DELAGÉNIÈRE, H. *Cong. franç. de chir. Proc.-verb.* Paris, v. p. 346, 1891.—144. SNOW, L. B. *Med. Rec.* xli. p. 41, 1892.—145. HOFMOKL. *Ber. d. k.k. Krankenanst. in Wien*, p. 334, 1891.—146. ELISCHER, J. *Pest. med.-chir. Presse*, xxviii. p. 274, 1892.—147. BRETTEAUER, J. *Am. J. Obst.* xxvi. p. 394, 1892.—148. LA TORRE, F. *Bull. d. r. Accad. med. di Roma*, xviii. p. 231, 1891-2.—149. EBERLIN, A. *Med. Obozr.* xxxvii. p. 1011, 1892.—150. ALBERTIN. *Province méd.* vii. p. 159, 1893.—151. GELLI, G. *Pratico*, ii. p. 123, 1892-3.—152. DOYLE, O. M. *Journ. Am. M. Assoc.* xxi. p. 773, 1893.—153. BOLDF, H. J. *Med. Rec.* xli. p. 790, 1893.—154. ANSCHELES, J. O. *Journ. akush. i jensk. boliez.* viii. p. 734, 1893.—155. FAIDHERBE, A. *Arch. de tocol.* p. 212, 1894.—156. VINEBERG, H. N. *Am. J. Obst.* p. 525, 1895.—156a. BUTTERS, W. *Diss.* Erlangen, 1895.—156b. JACOBI, M. P. *Am. Journ. Obst.* xxxvii. p. 510, 1895.—156c. DORLAND, W. A. N. *Phil. Poly.* iv. p. 485, 1895.—156d. CLAPHAM, C. *Quart. Med. Journ.* iv. p. 279, 1896.

**Uterus Fetalis, Pubescens, etc.:**—157. MÜLLER, P. *Ztschr. f. Geburtsh. u. Gyn.* iii. p. 159, 1878.—158. BUDIN, P. *Progr. méd.* pp. 267 and 307, i. for 1887.—159. BLANC, E. *Arch. de tocol.* p. 359, 1889.—160. TRACHET. *Arch. de tocol.* xvii. p. 845, 1890.

**Minor Malformations and Congenital Prolapsus Uteri:**—161. PENROSE, C. B. *Univ. Med. Mag.* vi. p. 185, 1893-4.—162. MUELLER. *Ann. di Ostet.* p. 331, 1894.—163. QUISLING, N. *Norsk. Mag. for Laegevidenskaben*, 4 R. iv. p. 265, 1889.—164. HORLACHER. *Münch. med. Wchnschr.* No. 50, 1889.—165. HEIL, K. *Arch. f. Gynaek.* xlvi. p. 155, 1894.—165a. REMY, S. *Arch. de tocol.* xxii. p. 904, 1895.



**Vagina Septa:**—166. SUPPINGER. *Correspondenzbl. f. Schweizer Aerzte*, p. 418, 1876.—167. ATTHIL, L. *Dublin Journ. Med. Sc.* lxiv. p. 165, 1877.—168. ANWAY, J. D. *Am. Journ. Obst.* xi. p. 388, 1878.—169. CHÉRON. *Rev. méd.-chir. d. mal. d. femmes*, iv. p. 382, 1882.—170. GALABIN, A. L. *Trans. Obst. Soc. London*, xxiv. p. 20, 1883.—171. MOULTON, H. *Journ. Am. Med. Assoc.* x. p. 666, 1888.—172. SCHÜLER, C. *Diss.* Kiel, 1890.—173. VASTEN, V. A. *Bolnitsch. gaz. Botkina*, i. p. 986, 1890.—174. PASCHEN. *Centralbl. f. Gynäk.* xiv. p. 16, 1890.—175. MASSEY, G. B. *Ann. Gynæc. and Pædiat.* iv. p. 365, 1890-1.—176. SHTOL, K. *Otchét. Mar. ginek. otidiel.* p. 47, 1891.—177. GUHMAN, M. *Journ. Am. Med. Assoc.* xvi. p. 906, 1891.—178. CURATULO, G. E. *Riforma med.* vii. p. 337, 1891.—179. CIAJO, A. *Gazz. d. osp.* xii. p. 670, 1891.—180. SCIALDONI, A. *Gior. internaz. d. sc. med.* xiii. p. 534, 1891.—181. HALTER, G. *Wien. med. Presse*, xxxiii. p. 49, 1892.—182. DRUJININ, I. N. *Journ. akush. i jensk. boliez.* vi. p. 239, 1892.—183. GIGLIO, G. *Riforma med.* viii. p. 185, 1892.—184. SICHERER, O. v. *Arch. f. Gynaek.* xlii. p. 339, 1892.—185. PICCOLI, G. *Levatrice mod.* i. p. 58, 1892.—186. EBERLIN, A. *Med. Obozr.* xxxvii. p. 323, 1892.—187. BORDÈ, L. *Bull. d. sc. med. di Bologna*, iii. p. 194, 1892.—188. FÜCHTENBUCH, H. *Diss.* Strassburg, 1892.—189. UMANORI, S. *Mino Igakkwai Hoko*, No. 1, p. 86, 1893.—190. FERMINI. *Boll. d. Poliambul. di Milano*, vi. p. 55, 1893.—191. LEUF, A. H. P. *Med. News*, lxiii. p. 490, 1893.—192. HERRICK, C. B. *Med. News*, p. 15, July 7, 1894.—193. ROBB, H. *Johns Hopkins Hosp. Bull.* p. 50, April 1894.—194. SEMELEDER, F. *Gaceta medica (Mexico)*, p. 287, 1894.—195. OSMONT. *Arch. d. tocol.* p. 139, 1894.—196. CHAPIUS. *Lyon méd.* p. 83, 1894.—197. AYERS, E. A. *Am. Journ. Obst.* p. 104, July 1894.—198. MERTENS. *Centralbl. f. Gynäk.* xviii. p. 1001, 1894.—199. RAINERI, G. *Ann. di Ostet.* p. 473, 1894.—200. SCHUHL. *Ann. de gynéc.* p. 248, Oct. 1894.—201. FORDYCE, W. *Teratologia*, i. p. 61, 1894.—202. SEREJINSKY, G. P. *Journ. akush. i jensk. boliez.* p. 183, March 1894.—203. ROUX, G. *Arch. de tocol.* p. 59, 1895.—204. SWOPE, S. D. *Med. News*, p. 391, April 6, 1895.—204a. CHAPMAN, F. B. *Boston Med. and Surg. Journ.* cxxxiii. p. 622, 1895.

**Vagina Rudimentaria. Defectus Vaginæ. Atresia Vaginæ:**—205. GARDE, H. C. *Australas. Med. Gaz.* ix. p. 307, 1889-90.—206. PICQUÉ, L. *Ann. d. gynéc.* xxxiii. p. 124, 1890.—207. SAHRENDT, P. *Ein Beitrag zu den Missbildungen der Vagina und des Hymen.* Greifswald, 1890.—208. JACOBSSOHN, J. *Diss.* Strassburg, 1890.—209. JACQUEMARD, C. *Loire méd.* ix. p. 229, 1890.—210. PASCALE, G. *Riforma med.* vi. pt. 1, 1890.—211. RIEDINGER, H. *Ztschr. f. Heilk.* xi. p. 237, 1890.—212. SOKOLOFF, A. P. *Ann. d. gynéc. et obst.* xxxiii. p. 47, 1890.—213. LEONTE. *Spitalul*, x. p. 611, 1890.—214. JEPSON, S. L. *Trans. M. Soc. W. Virginia*, p. 759, 1890.—215. MADDEN, T. M. *Trans. Roy. Acad. Med. Ireland*, viii. p. 292, 1890.—216. FRANK, K. *Ztschr. f. Geburtsh. u. Gyn.* xviii. Hft. 2, 1890.—217. ASADULLA, M. *Indian Med. Gaz.* xxvi. p. 9, 1891.—218. ROBB, H. *Johns Hopkins Hosp. Bull.* ii. p. 43, 1891.—219. SWIĘCICKI. *Wien. med. Bl.* xiv. p. 85, 1891.—220. LOVIOT. *Bull. et mém. soc. obst. et gynéc. de Paris*, p. 78, 1891.—221. ROUX. *Cong. franç. de chir. Proc.-verb.* v. p. 497, 1891.—222. DELAGÉNIÈRE, H. *Ibid.* p. 346, 1891.—223. VAGISHITA, T. *Sei-i-Kwai Med. Journ.* x. p. 170, 1891.—224. BALADE. *Journ. de méd. de Bordeaux*, xxi. p. 85, 1891-2.—225. KENNEDY, C. M. and C. F. *Univ. M. Mag.* iv. p. 703, 1891-2.—226. LA TORRE, F. *Bull. d. r. Accad. med. di Roma*, xviii. p. 231, 1891-2.—227. MARTIN, J. N. *Am. Gynæc. Journ.* ii. p. 287, 1892.—228. FULTON, J. S. *Am. Journ. Obst.* xxvi. p. 331, 1892.—229. MANGIAGALLI, L. *Atti. d. Assoc. med. Lombarda*, i. p. 32, 1892.—230. PLASENCIA, I. *Rev. de cien. med.* vii. p. 169, 1892.—231. SWIĘCICKI, H. DE. *Arch. de tocol. et de gynéc.* xix. p. 481, 1892.—232. ALBERTIN. *Province méd.* vii. 159, 1893.—233. AZEMA, H. *Ann. de gynéc.* xxxix. p. 214, 1893.—234. BARKER, F. C. *Indian Med.-Chir. Rev.* i. p. 140, 1893.—235. SKENE, A. J. C. *Brooklyn Med. Journ.* vii. p. 636, 1893.—236. BOLDT, H. J. *Med. Rec.* xiv. p. 790, 1893.—237. CURRIER, A. F. *New York Journ. Gynæc. and Obst.* iii. p. 1086, 1893.—238. ROSSA, E. *Centralbl. f. Gynäk.* xviii. p. 422, 1894.—239. COSTA, J. C. DA. *Med. News*, p. 269, Sept. 9, 1894.—240. SIMON, M. *Centralbl. f. Gynäk.* xviii. p. 1313, 1894.—241. GRANDIN, E. H. *Am. Journ. Obst.* xxxi. p. 249, 1895.—242. FEINBERG, B. *Centralbl. f. Gynäk.* xix. p. 395, 1895.—242a. TURGARD. *Ann. de la Polyclin. de Lille*, iv. p. 177, 1895.—242b. MURET. *Wien. klin. Rundschau*, ix. p. 537, 1895.—242c. HAHN, H. *St. Louis Med. and Surg. Journ.* lxix. p. 265, 1895.—242d. PICQUÉ and VILLAR. *Progr. méd.* p. 284, Nov. 2, 1895.—242e. PICQUE. *Gaz. méd. de Paris*, 9. s. ii. p. 522, 1895.—242f. WEBSTER, J. C. *Am. Journ. Obst.* xxxii. p. 544, 1895.—242g. ROSSA, E. *Centralbl. f. Gynäk.* xx. p. 145, 1896.

**Atresia Vaginæ Lateralis:**—243. WROBLEWSKI, C. *Diss.* Greifswald, 1884.—244. FRAENKEL, E. *Breslau. aerztl. Ztschr.* ix. p. 67, 1887.—245. SACHS, G. *Med. Obozr.* xxxvii. p. 130, 1892.—246. SICHERER, O. v. *Arch. f. Gynaek.* xlii. p. 339, 1892.—247. CULLINGWORTH, C. J. *Trans. Am. Gyn. Soc.* xviii. p. 434, 1893.—248. SÄNGER. *Centrabl. f. Gynäk.* xviii. p. 931, 1894.—249. MURET. *Rev. méd. de la Suisse romande*, p. 280, 1895.—250. KARRA, D. A. *Univ. izvyestiya*, xxxv. p. 149, 1895.

**Stenosis Vaginæ:**—251. VINEBERG, H. N. *Am. J. Obst.* p. 106, July 1894.—252. STONE, A. K. *Boston M. and S. Journ.* p. 533, 1895.

**Abnormal Communications of the Vagina:**—253. CARADEC. *Gaz. d. Hôp.* No. 7, p. 27, 1863.—254. ROSTHORN, A. v. *Wien. klin. Wchnschr.* No. 10, p. 183, 1890.—255. FORDYCE, W. *Teratologia*, i. p. 61, 1894.

**Double Vulva:**—256. SUPPINGER. *Correspondenzbl. f. Schweizer Aerzte.* p. 418, 1876.—257. WELLS, B. H. *Am. J. Obst.* xxi. p. 1265, 1888.—258. CHARLEONI, G. *Ann. di Ostet. e Ginecologia*, xvi. p. 469, 1894.

**Atresia Vulvæ Superficialis:**—259. RAUSCHNING, P. *Diss.* Königsberg, 1890.—260. SÄNGER. *Centrabl. f. Gynäk.* xv. p. 1022, 1891.—261. VOLLMER, H. *Diss.* Marburg, 1894 (two cases).—261a. HUE, F. *Med. infant.* ii. p. 467, 1895.—261b. JAN, M. *Indian Lancet*, vii. p. 123, 1896.

**Abnormal Communications of the Vulva:**—262. ELGEHAUSEN, F. *Dissertation.* Kiel, 1891.

**Anus Vulvalis:**—263. ROSTHORN, A. v. *Wien. klin. Wchnschr.* iii. p. 183, 1890.—264. SPINELLI, G. *Riv. clin. e terap.* xii. p. 173, 1890.—265. ABEL, K. *Arch. f. Gynaek.* xxxviii. p. 493, 1890.—266. SZUKALSKI, S. *Diss.* Greifswald, 1890.—267. PUECH, P. *Des abouchements congénitaux du rectum à la vulve et au vagin.* Paris, 1890.—268. FROMMEL, R. *München. med. Wchnschr.* xxxvii. p. 264, 1890.—269. HIMMELFARB, G. I. *Arch. f. Gynaek.* xlii. p. 372, 1892.—270. PARVIN, T. *Med. News*, lxi. p. 69, 1892.—271. RAUTZOIN. *Rev. mens. d. mal. d. l'enf.* xi. p. 27, 1893.—272. THOMPSON, H. *Lancet*, i. for 1894, p. 403.—273. HORROCKS. *Brit. Med. Journ.* i. for 1895, p. 83.—274. BUCKMASTER, A. H. *Trans. Am. Gyn. Soc.* xix. p. 275, 1894.—275. LUDWIG. *Centrabl. f. Gynäk.* xix. p. 349, 1895.—276. ANSHELESA, U. *Univ. izvyestiya*, xxxv. p. 129, 1895.—277. DWIGHT, T. *Am. J. Med. Sc.* p. 433, April 1895.—277a. FREEMAN, L. *Med. News*, lxvii. p. 319, 1895.

**Hypospadias:**—278. LEBEDEFF. *Arch. f. Gynaek.* xvi. p. 290, 1880.—279. STRONG, C. P. *Trans. Am. Gyn. Soc.* xvi. p. 473, 1891.—280. FRANK. *Wien. klin. Wchnschr.* v. p. 413, 1892.—280a. BITTNER, C. *Przegląd. chirurgiczny*, i. p. 260, 1893-4.

**Epispadias:**—281. GOTTSCHALK, S. *Dissertation.* Würzburg, 1883.—282. RUTHERFORD, C. *Med. Rec.* xxxviii. p. 492, 1890.—283. AUFFRET, C. *Cong. franç. de chir. Proc. verb. etc.* vi. p. 233, 1892.—284. DRANITZY, A. A. *Journ. akush. i jensk. boliez.* p. 567, June 1894.—285. DURAND, M. *L'Exstrophie vésicale et l'Epispadias.* Paris, 1894.—285a. PETREN, K. *Nordiskt. med. Arkiv*, n. f. iv. No. 31, 1894.—285b. KÜSTER, E. *Berlin. klin. Wchnschr.* p. 1141, 1895.

**Malformations of Labia:**—286. D'HOTMAN DE VILLIERS. *Arch. de tocol.* xvii. p. 272, 1899.—287. SCHTOL, K. G. *Journ. akush. i jensk. boliez.* iv. p. 807, 1892.—287a. DAVID, E. *Journ. sc. méd. de Lille*, xviii. p. 372, 1895.—287b. SHOEMAKER, G. E. *Am. Journ. Obst.* xxxii. p. 215, 1895.

**Atresia Hymenalis:**—288. VAN DER MELJ. *Nederl. Tijdschr. v. Verlosk. en Gynæc.* i. p. 171, 1889.—289. ALLINSON, H. C. *Brit. Med. Journ.* i. for 1890, p. 780.—290. MAHER, J. J. E. *Med. Rec.* xxxvii. p. 569, 1890.—291. SOMERS, L. N. U. *Lancet*, i. for 1890, p. 1010.—292. CERCHEZ. *Clinica*, i. p. 118, 1890.—293. SISMAN, A. *Wien. klin. Wchnschr.* iii. p. 433, 1890.—294. KINLOCH, R. A. *Am. J. Obst.* xxiii. p. 836, 1890.—295. MAYER, O. B. *Trans. South Car. M. Ass.* p. 105, 1890.—296. BARDESCU, N. *Spitalul.* x. p. 357, 1890.—297. BEVILL, C. *Med. Rec.* xxxviii. p. 631, 1890.—298. GICHNER, J. E. *Maryland M. Journ.* xxiv. p. 248, 1890-1.—299. WIGGIN.

F. H. *Med. Rec.* xxxix. p. 136, 1891.—300. SHTOL, K. *Otchet. Mar. ginek. otdiel.* p. 28, 1891.—301. ROSS, J. F. W. *Journ. Am. M. Ass.* xvii. p. 1, 1891.—302. HEMENWAY, H. B. *Am. J. Obst.* xxiv. p. 897, 1891.—303. STROGONOFF, V. V. *Vrach.* xii. p. 1058, 1891.—304. SOCHINSKI, P. M. *Vrach.* xii. p. 1139, 1891.—305. MIRONOFF, M. *Journ. akush. i jensk. boliez.* vi. p. 474, 1892.—306. WHEELER, A. *Calif. Homœop.* x. p. 206, 1892.—307. MINARD, E. J. C. *N. York M. Journ.* lvi. p. 299, 1892.—308. VANDERVEER, J. R. *N. York M. Journ.* lvi. p. 298, 1892.—309. KONELSKI, M. L. *Vrach.* xiii. p. 955, 1892.—310. ORLOFF, V. N. *Meditsina.* iv. p. 356, 1892.—311. ROSINSKI. *Allg. med. Centr.-Ztg.* lxi. p. 2041, 1892.—312. DRAKE-BROCKMAN, H. E. *Brit. Med. Journ.* i. for 1893, p. 1220.—313. NEUGEBAUER, F. L. *Medycyna.* xxi. p. 429, 1893.—314. NAMMACK, C. E. *Med. Rec.* xlv. p. 81, 1893.—315. THOMASON, H. D. *Ibid.* p. 235, 1893.—316. KAHN, A. *Med. News.* lxi. p. 380, 1893.—317. MUDALIER, A. N. K. *Indian Med. Rec.* p. 300, 1894.—318. MURPHY, J. *Brit. Med. Journ.* i. for 1895, p. 65.—318a. RITTSTIEG. *München. med. Wchnschr.* p. 1081, 1895.—318b. COROMILAS. *Bull. et mém. soc. obst. et gynéc. de Paris.* p. 445, 1895.

Anomalies in the Form of the Hymen:—319. SCHAEFFER, O. *Arch. f. Gynaek.* xxxvii. p. 199, 1890.—320. CORDORELI FRANCAVIGLIA, M. *Gior. ital. d. mal. ven.* xxx. p. 426, 1889.—321. MONTANE, L. *Progreso méd.* ii. p. 445, 1890.—322. PURSLOW, C. E. *Lancet.* i. for 1891, p. 543.

Anomalies in the Structure of the Hymen:—323. LEISENRING, P. S. *Omaha Clinic.* ii. p. 216, 1889-90.—324. DESTAREC, J. *Thesis.* Paris, 1890.—325. CAMPBELL, W. M. *Edin. M. Journ.* xxxvi. p. 217, 1890-1.—326. AHLFELD, F. *Ztschr. f. Geburtsh. u. Gynäk.* xxi. p. 160, 1891.

Hermaphroditism:—327. BALLANTYNE, J. W. *Teratologia.* i. p. 136, 1894.—328. *Ibid.* *Teratologia.* ii. p. 184, 1895.—329. DEBOUT. *Normandie méd.* v. p. 160, 1890.—330. DECKER, C. M. *St. Louis M. and S. Journ.* lviii. p. 355, 1890.—331. EGEE, R. *Gac. med.* xxv. p. 141, 1890.—332. ROSENTHAL, O. *Wien. med. Wchnschr.* xl. p. 526, 1890.—333. WINTER. *Ztschr. f. Geburtsh. u. Gynäk.* xviii. p. 359, 1890.—334. MANTON, J. A. *Lancet.* ii. for 1890, p. 395.—335. Pozzi, S. *Gaz. hebdom. de méd.* xxvii. p. 351, 1890.—336. JONES, C. N. D. *Med. Rec.* xxxviii. p. 724, 1890.—337. TILLATSON, D. J. *Med. and Surg. Reporter.* lxiii. p. 647, 1890.—338. ABEL, R. *Dissertation.* Greifswald, 1890.—339. VAUGHAN, G. T. *New York Med. Journ.* liii. p. 125, 1891.—340. POLAILLON. *Bull. Acad. de méd. Paris.* xxv. p. 557, 1891.—341. ELIOT, G. T. *Med. Rec.* xxxix. p. 564, 1891.—342. PETIT, P. *N. Arch. d'obst. et gynéc.* vi. p. 297, 1891.—343. JOUIN. *Bull. et mém. soc. obst. et gynéc. de Paris.* p. 190, 1891.—344. DEBIERRE, CH. *L'Hermaphrodisme.* Paris, 1891.—345. BREITUNG, M. *Dissertation.* Jena, 1891.—346. ROERLE, F. J. *Trudi Obsk. Russk. vrach v Mosk.* p. 17, 1891.—347. BISHOP, H. D. *Med. Rec.* xli. p. 321, 1892.—348. WORRALL, R. *Australas. M. Gaz.* xi. p. 107, 1891-2.—349. FEHLING, H. *Arch. f. Gynaek.* xlii. p. 561, 1892.—350. MESSNER. *Arch. f. path. Anat.* exxix. p. 203, 1892.—351. NONNE, M. *Jahrb. d. Hamb. Staatskrankenanst.* ii. p. 446, 1892.—352. GUERMONPREZ. *Une erreur de sexe avec ses conséquences.* Lille, 1892.—353. FRANK. *Prag. med. Wchnschr.* xvii. p. 221, 1892.—354. RICHER, P. *N. iconog. de la Salpêtrière.* v. p. 385, 1892.—355. DAILLIEZ, G. *Les sujets de sexe douteux.* Lille et Paris, 1892.—356. LINDSAY, J. *Glasgow Med. Journ.* xxxix. p. 161, 1893.—357. KURZ, A. *Deutsche med. Wchnschr.* xix. p. 964, 1893.—358. PHILIPPE, P. *Union méd. du Canada.* vii. p. 505, 1893.—359. AUDAIS, L. *Ann. de gynéc. et d'obst.* xl. p. 362, 1893.—360. BERGONZOLI, G. *Bull. scient. No. 1.* 1893.—361. Pozzi, S. *A Treatise on Gynaecology.* iii. p. 452, 1893.—362. BROHL. *Centralbl. f. Gynäk.* xviii. p. 390, 1894.—363. HOFFMANN, C. S. *Am. J. Obst.* xxix. p. 367, 1894.—364. MARTIN, C. *Brit. Med. Journ.* i. for 1894, p. 1361.—365. WALKER, M. A. *New York Med. Journ.* p. 434, Oct. 1894.—366. ZUCCARELLI, A. *L'Anomalo.* p. 78, 1894.—367. WILLETT. *Trans. Path. Soc. London.* xlv. p. 102, 1894.—368. MOOSTAKOV. *Meditsina (Bulgaria).* p. 32, 1894.—369. SCHNELLER. *München. med. Wchnschr.* No. 33, 1894.—370. HALLOPEAU, H. *Bull. Acad. de méd. Paris.* p. 425, 1895.—371. LAGNEAU, G. *Ibid.* p. 415, 1895.—372. MEIGE, H. *N. iconogr. de la Salpêtrière.* p. 56, 1895.—373. PEAN. *Bull. Acad. de méd. Paris.* p. 381, 1895.—374. TARGETT, J. H. *Trans. Obst. Soc. London.* xxxvi. p. 272, 1895.—375. ZEPDEL, J. *Ztschr. f. Geburtsh. u. Gynäk.* xxxii. p. 230, 1895.—375a. LIPKA, A. *Gaz. lekarska.* xv. p. 980, 1895.—375b. BITTNER, W. *Prag. med. Wchnschr.* xx. p. 491, 1895.—375c.



MINOT, F. *Boston Med. and Surg. Journ.* cxxxiii. p. 112, 1895.—375*d*. STRETTON, J. L. *Lancet*, p. 917, ii. for 1895.—375*e*. NEUGEBAUER, F. *Przeegląd chirurgiczny*, ii. pp. 82, 539, 1894-5.—375*f*. KAPLAN, P. S. *Diss.* Berlin, 1895.—375*g*. BLOM, R. *Centralbl. f. Gynäk.* xix. p. 685, 1895.—375*h*. ARÈNE. *Loire méd.* xiv. p. 187, 1895.—375*i*. HUTCHINSON, J. *Arch. Surg.* vii. p. 64, 1896.

J. W. B.

## THE ETIOLOGY OF THE DISEASES OF THE FEMALE GENITAL ORGANS

THE causes of the diseases of modern women are mainly attributable to the errors, direct or indirect, of modern life, which is yet very far from perfection. They may be thus classed—

- I. Abnormalities, which are produced by
  - A. Hereditary congenital deficiencies of development, with
    - (*a*) Reversion to an anterior biological type; or
    - (*β*) Imperfection of adjustment, or of function, of certain structures;
  - B. Congenital, or subsequent arrests of development by bacillary inflammation or accident; and
  - C. Constitutional defect, in which certain classes of cells morbidly proliferate, forming tumours.
- II. The training and effects of education.
- III. Unnatural personal habits with regard to dress, diet, repose, and the management of the excretions.
- IV. Absence of marriage, or late or ineffective marriage; the last including absence of pregnancy by congenital defect or incapacity of the husband, or of the woman; and artificial prevention of pregnancy.
- V. Excessive use and drain of the sexual organs.
- VI. Bacillary contagious diseases, such as syphilis, gonorrhœa, puerperal septicæmia, tuberculosis, measles, scarlatina, small-pox, and diphtheria.
- VII. Accidental causes and those due to operation.

**I. Deficiencies and arrests of development**, which render the genital organs useless or lead to disease, might be attributed to inflammatory interference with the circulation and nutrition due to maternal endometritis, or mental shock; but these influence the whole embryo, or not especially its genital system. The cause is rather to be found in the influences of hereditary sexual feebleness, progressive in certain temperaments; or of bacillary inflammation; or of local injury in the mother.

A. Such defective heredity is probably not generally immediate, but is a gradual declension, generally on the maternal side, tending by continuous degeneration to induce in the progeny feeble sexual formation, frequently in the uterus. Thus the first stage may be found in a woman of deficient sexual appetite, having a uterus of moderate development, but contracted at its opening, which may be lacerated in her first con-



finement so, perhaps, as to prevent further conception. The child, cold-mannered, unsympathetic and egoistic, with a feebly developed uterus and disgust at marital rites, becomes pregnant only by chance — it may be long after marriage, or after successful operation : or, with a congenitally contracted, though permeable upper vagina, closed hymen, or a tendency to the infantile pelvis with absence of sexual appetite, she becomes the mother of one child, who has a yet feebler unimpregnable uterus and atrophic ovaries, with deficient catamenial discharge, and a premature menopause; or more marked abnormality may occur, and the woman be sterile. In the father hypospadias may exist, or some other state of deficient congenital urogenital formation. Such unions are often attributable to the inducements of money or position in marriage; in a simpler state of society they would be prevented by the competitive success of those physically more robust. This heredity may be rectified in the children if the feebly sexual woman become pregnant by a partner of exceptionally vigorous type, whereby the tendency to sexual deterioration may be neutralised.

Through the ancestral series a certain portion of the original germ-plasma has been retained, so that the special organisation is preserved, as well as some particular attributes, whether physical or mental, of the parents or earlier progenitors. The influence of the highest progressive development attained is thus conveyed to the offspring, but with it the inherent capacity of recurrence to an anterior lower type. A defective generative vitality may thus fail to develop to the highest type of the immediate ancestors, and reversion to an anterior form may occur.

As in all cases the special type of the individual is dominant, the impression of descent is one of degree, and the grade is in a proportionately decreasing ratio removed from that of the immediate ancestors; and this appears in some special point, in which the advanced cell-vitality has failed. This is particularly liable to occur in the generative organs, especially of women, which are more advanced and complicated.

Darwin says that the most ancient progenitors of the Vertebrata, of which we are able to obtain an obscure glance, seem to have been a group of marine animals resembling the larvæ of existing ascidians. These animals probably gave rise to a group of fishes, as lowly organised as the lancelet; and from these the ganoids, and other fishes like the lepidosiren, were probably developed. From such fish a very small advance would carry us on to the amphibians. Birds and reptiles were once intimately connected together, and the monotremata now connect mammals with reptiles in a slight degree. In the class of mammals the ancient monotremata led up to the ancient marsupials, and these to the early progenitors of the placental mammals. Thus we may ascend to the lemuriadæ, and from these the interval to the simiadæ is not very wide. The simiadæ then branched off into two great stems, the New World and Old World monkeys; and out of the latter stem, at some remote period, man, the wonder and glory of the universe, proceeded.

Geddes and Thomson state that in all the lower vertebrata the

two oviducts are distinct throughout the genital canal; but in mammals the division is found only in the monotremata. In marsupials the vagina is single, but the uterus double; and in most placentalia the upper portion of the uterus is double.

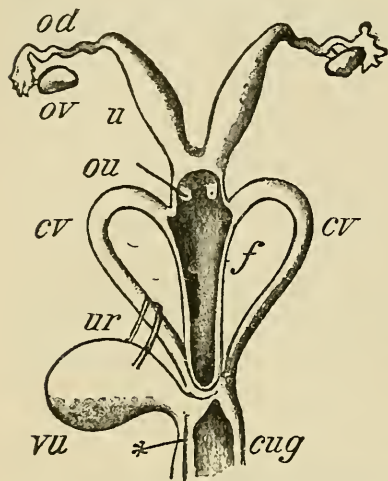

FIG. 40. — Female generative organs of *Halmaturus* (Gegenbaur). *ov*, Ovary; *od*, oviduct; *u*, uterus; *cv*, vaginal canals; *cug*, sinus urogenitalis; *vu*, urinary bladder; *ur*, ureter. \* Opening of the bladder.

tary deficiencies of development are reversions to an anterior type.

These abnormalities, however, are more particularly attributable to the exact point at which the progressive development of the germinal

Gegenbaur describes the progress in development in the marsupialia in which the two uteri are distinct, and two separate vaginæ appear (Fig. 40), and says that in many rodents (*lagostomus*) a certain portion of the vagina retains its original double nature. The gradual biological progress toward the human double uterus is shown in Figs. 41, 42, 43, in which it is also seen that when the common portion of the uterus is elongated the cornua are shortened. In the simiadæ, as in man, there is a single uterus.

The same line of proof may be applied to lobate and multiple ovaries, and to the various conditions of hermaphrodites. Thus heredit-

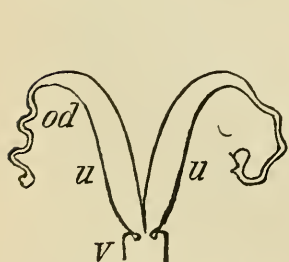

FIG. 41. — Two completely separated uteri of many Rodentia.

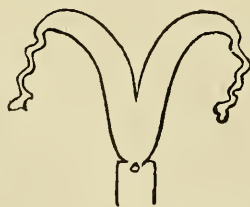

FIG. 42. — The single uterus is continued into two separate cornua of the Insectivora, Carnivora, Cetacea, and Ungulata.



FIG. 43. — The single uterus of the Simiæ and Man.

Various forms of the uterus (Gegenbaur). *u*, Uterus; *od*, oviduct; *v*, vagina.

cells fails. Pure reversion to an anterior type implies a perfect development at the level of that ancestor; this, however, may not occur. Probably no defective development can take place without a deficient germinal cell-vitality, and such vitality may be exhausted at a point antecedent to that of completion of the anterior type. Thus examples may be found in which the condition may be described as deficient in

contrast with that of arrest. In the former the cell vitality is low, but persistent; in the latter it is worn out and atrophic.

B. And here presents itself a special cause of germinal-cell destruction by bacillary action, which is, through parental influence, directly conveyed to the embryo, and by local inflammation destroys the vitality and power of growth of germinal genital cells. Among such causes are the eruptive fevers, such as measles, scarlet fever, and small-pox, by which the fœtus in utero may be attacked. Syphilis probably also exerts a determining influence on arrests of development in the progeny.

After birth, and at any time previous to full development, these causes, or tuberculosis again, which specially attacks the mucous or serous membranes, may affect and destroy the vitality of the growing cells; or an accident before birth, or subsequently, such as a blow on the abdomen producing an internal hæmorrhage, peritoneal or otherwise, and affecting these parts, may arrest growth; or a peritonitis may cause displacement and adhesion of the genital organs.

Such destruction of vital force in the special germ-cells produces arrest of development at the stage which such development had previously attained, and a stage of arrest restricted to the special cells thus affected.

There is no necessary relation between any degree of defect or arrest in the development of the pelvic sexual organs and the degrees of perfection of female form and of the rest of the woman.

Congenital deficiencies and arrests of development are found in the ovaries, Fallopian tubes, uterus, vagina, hymen, and vulva.

Should the development of the genital ridge be deficient or arrested the ovaries are so undeveloped that the external germinal epithelium has not ingrown for the formation of the Graafian follicles; or is so wanting in completeness of structure, that these organs are unable to arrive at their successive monthly maturity. Whence result amenorrhœa and sterility.

If the growth of the cephalad part of the Müllerian ducts, and of the mesenchyma of the urogenital fold cease, the Fallopian tubes are minute or defective. By absence of fusion of the cephalad ends of the two Müllerian ducts in the genital cord, which are always tubular, the uterus is double; by absence of fusion of the upper ends of the cephalad end, and its presence in the lower part, the uterus is bifid; from arrest in one duct and development of the other, the unicorn uterus results; after the normal fusion, cessation of vital growth may cause the uterus to be diminutive.

When the vital force is defective or arrested in the lower half of the genital cord, so that fusion and absorption of the internal walls of the two Müllerian ducts do not occur but the remaining development continues in each, the epithelial surfaces of each may separately continue their growth, meet and coalesce, closing the canals, and forming the proliferating cellular lamina; the central duct-cells may subsequently liquefy normally, and result in two vaginæ of more or less perfect formation. When the central cells of the ducts have failed to break

down, no vaginal canal is formed; or the cells of one may have liquefied, when one vagina, perhaps of defective size, is present. Such cohesion of the vaginal walls may be maintained only by a thin, delicate, easily separated layer of the central epithelial cells, liquefaction of the central lamina having just failed of completion.

The hymen, a non-muscular fold which projects into the urogenital sinus, having on the outer surface the epithelium of the sinus and on the inner that of the vagina, may be imperforate by arrest of liquefaction of the lowest cells of the vaginal lamina, and non-formation of a canal; or may have an opening into each canal of a double vagina by absence of fusion of the lower ends of the Müllerian ducts; or have two openings into a single vagina by non-fusion of the lowest Müllerian duct-walls, with liquefaction of the central epithelial cells of each.

Deficient formation of the clitoris and nymphæ is due to defect or arrest of development of the genital tubercle; and of the labia majora, of the mesodermic prominences on either side of the genital tubercle.

The diseases which result from defect or arrest of development in atresia with ovaries so well formed that the catamenia occur, depend upon distension of the genital canal, which is patent above the occluded portion, by the collection of the retained menses. Thus, with a closed hymen, or atresic vagina, the menses may dilate the vagina, collect in the uterus, and fill and distend the tubes up to the fimbriæ. Should effusion of the menses occur through the fimbriæ into the peritoneum, peritonitis results, of a degree of mildness or severity proportionate to the quantity and quality of the fluid effused if it occur before operation for the cure of the atresia; it will probably be septic and virulent if it occur after it.

Each segment of the double uterus may contain an impregnated ovum, the two perhaps of different ages; and thus superfœtation may be simulated.

The usually more feeble structure of an unicorn uterus, or of a segment of a bifid uterus, occupied by an impregnated ovum in progress of development, may cause its rupture into the abdominal cavity, and thus produce abdominal hæmatocele and peritonitis.

Supernumerary developments, as of nipples, are multiplications due to recurrence to an anterior type; or to embryonic separation or migration of the special epidermal cells; and duplication, as of ovaries, is attributable to embryonic cleavage. Duplication of the ovaries, if overlooked in oophorectomy for the production of the menopause, may defeat the object of the operation.

The deficiency or absence of sexual appetite, and thus of engorgement of the erectile structures, is attributable to defective nerve formation in the vaginal plexus of the pelvic or inferior hypogastric plexus, and tends to feebler development of progeny from diminished size of the supplying vessels. This is the most common deficiency of development in these organs in civilised people: it is frequently, though not necessarily, associated with the presence of a congenitally feeble uterus; and also, but less



commonly, with a uterus which is normal, except that there is deficiency in size of the external opening: all these things tend towards sterility or limitation of propagation, either by direct prevention of the entrance of the sperm, or by that frequent refusal of intercourse, and subsequent avoidance by the husband, which is commonly known as incompatibility of temper.

The uterus, with normal length of cavity but of feeble development, may be deficient in size, strength, and weight; and may have a feeble cervico-corporeal junction, so that the body, unable to maintain its normally slightly anterior curvature, may fall by the pressure of the intestines above it into the horizontal position; the cervix, on the other hand, readily yielding to the anterior force of a distended rectum, looks forwards and downwards; thus the ante flexion of the feebly developed uterus ensues. With this in the marked condition, is coincident deficiency in size of the opening, so that obstruction — by the angle of the ante flexion — to the passage of the secretions increases the tendency to their delay within the cavity of the uterine body: the latter is thereby the more strongly depressed into the horizontal position, and dysmenorrhœa and sterility result.

The cervicitis occasionally found in connection with the feeble ante flexed uterus is thus produced. The secretions collect within the cavity of the body by the obstruction at the inner os, which is usually caused by the angle of flexion; distension then induces muscular contraction, and this forces the menstrual blood past the angle into the cervical canal; but as the external opening is congenitally minute, escape is again hindered, and the cervical cavity is thus also dilated: the quantity of the corporeal secretion increases, muscular contraction follows, and escape is effected; but the cervical membrane at the external os has been depressed, irritated, inflamed, thickened, everted, and become granular, and this, however slight it may be, narrows the opening yet farther. The cervical tubulo-racemose glands have been compressed by the pressure of the secretions, and their mucus is thus retained within their tubules; they become irritated and inflamed, and secrete an increased quantity of mucus, which becomes abnormally cohesive andropy. This mucus presently extends from the columnar secreting cells in the glands, occupies their canals, unites with the secretion of adjacent glands, fills the cervix, projects through the external os, and by its constant pressure gradually dilates the external os. Thus at the time of examination the cervix may present downwards and forwards, the external opening may be of normal size and occupied by cervical mucus, the cervical canal may be dilated, the inner os, perhaps lying to the side of the central line from unequal lateral hyperplasia, may be difficult to find: the body of the uterus may be horizontal, forming an acute angle of ante flexion with the cervix, and the whole uterus may be of feeble structural development, although it may measure  $2\frac{1}{2}$  inches in its canal. The dysmenorrhœa may have ceased or not, according to the degree of stenosis, by bending or hyperplasia of the inner os; but sterility remains.

The dysmenorrhœa which occurs a day or so before the flow is due to engorged vessels in the endometrium around the utricular glands and on the mucous membrane, of which the columnar epithelial cells and underlying connective-tissue-matrix are proliferated; so that the general structure is thickened, and presses on the irritable nerves derived from the pelvic plexus — the pain being referred to the promontory of the sacrum, and ceasing when escape of blood from the vessels relieves their tension. But the dysmenorrhœa occurring synchronously with the flow, in consequence of rapid uterine distension and contraction necessary to overcome obstruction, is felt at the lower abdomen in the uterus itself; and this ceases when the stenosis has been overcome and continuous escape established.

The normal uterus may be deficient only in the form of the conical cervix, or in the size of the external opening — due, in the former case, to deficient cervical structural development, and, in both, as to size of the opening, to deficiency of development of the lower part of the cervical canal, or to undue contraction of the lower circular muscular fibres. The body may be weighed down by temporary catamenial retention or excessive abdominal pressure, and thus be horizontal, occasioning some stenosis by bending at the upper cervix: generally speaking, dysmenorrhœa and sterility will ensue.

Again, the uterus may be well and strongly developed in all other respects, but the cervical mucous membrane at the external orifice, which often extends on to the vaginal face of the cervix, may extend within the cervical cavity. The simple early embryonic epithelium, lining the cavity of the genital canal during development, changes its character in the lower third, which is the vaginal portion, becoming there a stratified pavement epithelium, which passes very gradually into the cylindrical epithelium of the upper, uterine portion. The change progresses upward, and, as it advances, the demarcation between the two kinds of epithelium becomes sharper, and at the eighth month of utero-gestation is abrupt at the junction of the uterine with the vaginal canal; the vaginal stratified epithelium often extends a short distance inside the os uteri (Minot), but, on the other hand, frequently fails to reach it. This congenital, apparently granular os is attributable to one or other of the following conditions: —

(1) That the vaginal stratified epithelium is deficient in extent of growth up to the lower border of the cervical canal, and thus the cylindrical epithelium projects into the vagina, and is exposed; or

(2) That the lower cervical glands and cylindrical epithelium, being developed beyond the enclosed lower cervical opening, remain exposed, because the circular muscular fibres, which become distinct about the close of the fifth month, do not subsequently contract at the lower border of the cervical canal sufficiently to include them within the canal.

The effect of this exposure of the glandular structures at the external opening of the cervix to the influences of the acid vaginal secretions, and to friction against the vagina on movement, intensified by fixation due to

abnormal abdominal pressure, is the production of an excessive supply of blood, which causes congestion and inflammation of the glands and increased secretion of their strongly cohesive mucus, which plugs the canal: the uterine vessels thus becoming enlarged, a varicose state may be induced, and the whole uterus become congested, so that general endometritis ensues. Also, the connective tissue at the face of the cervix becomes hyperplastic, the lips are compressed, and thereby the secretions, which are usually plentiful, find difficulty in escape: the uterus becomes irritated by distension, so that endometritis is increased, and evolutionary disease of the tubes, peritoneum, and ovaries, and (under the concurrent influence of excessive abdominal pressure) ante flexion or retroversion ensue: hence result virginal menorrhagia and dysmenorrhœa, and sterility on marriage.

Vigorous sexual development is specially noticeable in families and races which bear many children, among which may be particularly mentioned nations inhabiting or derived from the warmer climates. Of these, Jewesses are liable to the congenital granular os of strong formation, and to the small external opening. These conditions are compatible with coincidence of such a deficiency of development as permits the closure, or almost complete closure, of the genital canal by the hymen.

The deficient structure of the cervix of the feeble ante flexed uterus, through the small opening of which the sperm has by chance passed and impregnated the ovum, is, even on the hypernutrition of pregnancy, ill adapted to bear the strain of dilatation in labour. The pressure of the membranes does not act to advantage on the minute opening, so that the cervix may be stretched out and rigid, and the wedge of the membranes unable to engage. Thus the circular fibres are irritated, are in a state of tonic spasm, and act at advantage; but the longitudinal fibres, being lengthened by the downward pressure of the rounded membranes, act at disadvantage. Should the expulsive force be sufficient and the spasm continue, laceration of the cervix may be very extensive; or the lower segment of the uterus may rupture or be torn off.

On dilatation, the circular muscular fibres are deficient in strength and the cervix in structural breadth; thus laceration is frequent.

In the strong uterus with a deficiently developed os, there is a liability to laceration from the comparative non-dilatability of the small opening. Should bilateral laceration occur, lateral eversion takes place from contraction of the two halves of the torn circular muscular fibres; and horizontal eversion of the cervical face from contraction of the longitudinal muscular fibres, which are no longer restrained by the circular. But the edges of the wound are healthy, and the epithelium may readily spread thence on to the raw surfaces, unless prevented by subsequent vaginal friction from undue abdominal pressure.

In unilateral laceration eversion is apt to be slight; the circular fibres are ruptured at one side only, and the other side remains of strong structure, sufficient to counteract the longitudinal contraction and prevent eversion of the face of the cervix; the circular fibres, on

the other hand, having only one line of laceration, retract at slight advantage. Thus the eversion is only unilateral, and of small extent.

These actions, necessarily less marked in the feeble cervix because it is small in every direction, are accentuated in the large, strongly developed cervix.

To pressure in labour, long continued by the difficulty of dilatation of the small opening or other conditions of obstruction, may be due, by stasis of blood, the necrosis of tissue which, on separation after a few days, permits the passage of the excretions of the adjacent bladder or rectum affected, as well as of the slough, through the genital canal. Thereby a sinus is formed, called vesico-vaginal, recto-vaginal, or other fistula.

In pregnancy in the strong uterus, with the virginal everted granular face and hyperplasia, from the large size of the opening dilatation proceeds readily up to a certain point, when the head commences to pass. But the connective hyperplasia is ill adapted to excessive dilatation; and, when the great strain of expulsion of the head through the cervix is put upon it by the well-developed uterus, extensive laceration of the cervix usually results. The subsequent granular face and eversion are apt to be great; for the previously granular hyperplastic membrane is not readily susceptible to epithelial growth, and the raw and deeper newly lacerated central faces are thus far removed, except at the sides, from vaginal epithelium. Moreover, the longitudinal cervical muscular fibres act at advantage, so that the lower edges of the faces are drawn upwards and outwards, and everted. This action is not restrained by the circular fibres, which are torn across; hence the lateral edges of the cervical wound are drawn outwards, and still more everted.

In subsequent confinements the extent of laceration is generally increased, since the angles of previous laceration are healed by cicatricial connective tissue, which is ill adapted for dilatation; or they may also be hyperplastic, which is still less so, being softer and less strongly formed and resistant.

When the first stage of labour has been unduly prolonged by delay in dilatation of the strong cervix with deficient formation of the os, the uterus is liable to become irritable, and to be aroused to excessive vigour of contraction, in which, owing to the pain and general excitability of the woman, the accessory muscles participate; thus labour is precipitated and the head may be forced down with violence on the perineum. Should the power be much greater than the resistance, the head may burst through the perineum before the muscular structures have had time to dilate; whence perineal laceration, which is extensive in proportion to the want of due relation of these forces. Or the vagina and perineum, rigid in accordance with deficient sexual appetite and development, may not have sufficiently softened in pregnancy, and may not readily dilate, so that in the passage of the child perineal laceration occurs.

From deficiency of dilatation from the foregoing causes it may be necessary that assistance by the forceps be given to the passage of the child. The state of the parts, whether of the cervix or perineum, ren-



ders a gradual advance most appropriate; while the condition and feelings of the woman, weary and in excruciating pain, seem to indicate the desirability of speedy delivery. Under such circumstances the forceps are very often used without an anæsthetic, and laceration is frequently thus effected; even if the head have not passed through the cervix the forceps may be made to draw it down quickly, after which the increased pain by pressure on the perineum as yet unstretched induces the attendant to hurry, and a few minutes only may be given to dilatation in place of the two hours which nature would have employed. But if chloroform be given these influences are lessened, dilatation may be quietly effected, and laceration prevented or limited.

If the fresh, raw surfaces at the cervix or perineum, lacerated deeply into the broad ligament or recto-vaginal connective tissue respectively, absorb septic germs, a pelvic cellulitis results commensurate with the virulence of the sepsis. If of the most violent type, there is a general suppurative œdema of the connective tissue and suppurative phlebitis, and death probably ensues. Or, the microbial attack being less virulent, a suppurative thrombus may be impacted in a vein, guarded toward the heart by a sufficiently healthy adherent clot, and the increasing pus may burst through the venous wall, infecting the adjacent connective tissue and presenting in the direction of least resistance: if the microbes be detained in the lymphatic glands a similarly localised pelvic suppuration may occur. A local necrosis of connective tissue at the site of laceration may escape by the genital canal, or a benign inflammation terminate in resolution.

The morbid influence of the micrococci is effective only so long as the power of the septic micro-organisms is greater than that of the phagocytes and leucocytes, so that the former force a passage into, and are carried by the lymphatic and blood vessels into the general system; if the latter presently overpower and destroy the micrococci, the healing process forms granulations guarded by an army of victorious cells, and parasites can no longer gain admission, though they may create a local superficial suppuration [*vide* article on Inflammation].

It is not rare that the angle of laceration in the cervix has been so high that the tension of the growth of the ovum in succeeding pregnancies causes such irritation as exaggerates the normal uterine contractions, and miscarriage or premature labour results.

The appropriation of the absorbing, healing, and nutritive action of the lymphatic and blood vessels in such inflammation of the lacerated cervix, at the expense of that which the removal and renewal of the parts requires, usually results in subinvolution of the ligaments, and of the muscular, connective, venous, and nerve tissues of the pelvis and general system in proportion to the strength of the inflammation, its extent, and the degree of its subsequent continuance and drain. Should laceration of the perineum, as well as of the cervix, have occurred, subinvolution of all the genital structures generally results; if only of the one or the other, then of the parts specially allied to the nutrition of that one.

The misplacements which may arise in connection with subinvolution are described in section 3.

The subsequent occurrence of sterility or pregnancy is dependent on the degree to which the cervical circular muscular fibres and external cervico-vaginal wall are lacerated, effecting more or less eversion up to the level of the uninjured canal; should the opening in such complete lateral laceration be narrowed by the pressure of everted cervical mucous membrane and ensuing hyperplasia, whereby the normal trumpet-shaped opening is lost, the sperm cannot enter, and sterility results; or a cervicitis and endometritis may result from vaginal friction, and mucous secretion plug or fill the uterine tube. But if the laceration do not extend through the outer wall of the vaginal cervix, the canal may be of an enlarged trumpet-shape, and the sperm enter with unusual readiness; or the end of the penis may penetrate such a canal, and directly inject the sperm into it, effecting rapidly recurring pregnancies.

The state of constant excessive proliferation of cells of low type by the granular hyperplastic lacerated cervix is most favourable to the development of cancer, which is further discussed in section C, on constitutional causes.

Endometritis, with or without displacement and subinvolution in the parous, having been induced by one or other of the causes previously mentioned, or by the action of special microbes, as of gonorrhœa or puerperal septicæmia, some thickening toward the uterine end of the Fallopian tube, which is only of the size of a fine bristle, takes place by extension of the endometrial inflammation to the tubal mucous membrane and the consequent obstruction frequently increased by stenosis of the cervical canal, which mechanically hinders or prevents escape of the uterine and tubal secretions.

The secretions, accumulating in the tube, overflow through the fimbria into the abdominal cavity, whereby an irritation or inflammation of the peritoneum is caused proportionate to the quantity and quality of the fluid effused; peritonitis being always due to the entrance of irritating matter — gaseous, fluid, or solid — into the abdominal cavity directly, or by transudation under great inflammatory distension. In the effusion of a bland fluid — as of a healthy tubal mucus, mild ovarian follicular fluid, small quantities of blood or healthy urine — the irritation may not amount to more than an excitation of the peritoneal endothelial cells for the purpose of its absorption, and the fimbria may remain free and uninjured. On the relief of an existent cervical cause of endometritis, such as granular eversion, virginal or from laceration, the tubal stenosis may cease; and the tube may again become normal. Should the effusion be more irritating and septic, fibrin is exuded by inflammatory action of the peritoneum; thickening of adjacent structures, or adhesion by connective tissue organisation of the exuded fibrin occurs, and the fimbria of the tube becomes attached and closed; the tubal secretions, collecting in the more dilatable mid-part of the tube, then distend it, and a pyosalpinx is formed. Under pressure the uterine end may yield and the

pus escape through the genital canal: if this do not occur and the bacterial virus be moderate in power and become attenuated, the secretion may not increase in quantity; pus-cells may undergo fatty degeneration and absorption, and a more or less stationary hydrosalpinx presently result: or, again, if the healing process be less complete, caseous pus may persist. But if the bacteria be virulent in quantity or quality pus continues to collect, and, by increasing pressure, a gradual thinning of the tubal wall at the site of least resistance takes place. As the inner coats of the tube break down, its peritoneal coat yields, and presently a minute perforation permits a slight effusion into the peritoneal cavity. Thereupon an exudation of fibrin occurs about the site of such rupture, and the peritoneal surfaces of the tube and the adjacent viscus (commonly intestine) cohere. As the tubal distension continues to increase, an opening through the united peritoneal layers into the viscus occurs, and the pus escapes from the tube. Through this opening, or by penetration through the adherent, inflamed, distended, thin, intervening structures, bacilli from the viscus, such as the *bacillus pyogenes fœtidus* from the intestine, may enter the tube and render the pus fœtid. Sudden pressure may cause rupture directly into the peritoneum and a virulent peritonitis. In labour the pressure of the fœtal head may rupture the pyosalpinx into the broad ligament, and thus extensive suppurative connective tissue may spread in the direction of least resistance, the vigour of the extension being dependent on the character of the bacillary cause of the tubal suppuration: it is specially virulent in gonorrhœal infection.

Should the effusion from the fimbria be of a virulent character, such as septic pus, there may be a preliminary slight oozing which, while creating a severe inflammation of the adjacent peritoneum at the site, yet permits the exudation of organisable fibrin at a slight distance, so that the fimbria becomes encapsuled, and perhaps adherent; but a septic abscess may thus be originated by this effused pus between the fimbria and the adherent viscus; whence arises a tubo-peritoneal abscess, which may be tubo-ovarian. If there be more extensive peritonitis with distant organised adhesions, peritoneal abscesses, perhaps saprous by intestinal bacterial transudation, may be formed; and the omentum, by lymphatic absorption, may be studded with abscesses and adherent to the abdominal wall. But if the effusion be large or continuous — as of such septic pus, when organising fibrin has not been exuded, or has not attached and occluded the fimbria on account of the virulence of the effused matter — the peritonitis is general and virulent, and the exudation sero-purulent with occasional cohering fibrin-flakes.

The peritonitic exuding organising fibrin may attach adjacent abdominal or pelvic surfaces, as those of the uterus, tubes, ovaries, intestines, vermiform appendix, omentum, or abdominal or pelvic wall; or form bands like floss-silk, violin strings, or tapeworm. The intestines, during the period of acute inflammation, are comparatively stationary, except for gaseous distension; but during the period of convalescence they undergo considerable alteration in position by vermiform action. The connective

tissue adhesions become stretched by these movements of the intestines; and, later, may constrict them, and produce various degrees of obstruction to the passage of flatus or fæces, and to the circulation of the blood. Between extensive organised fibrinous adhesions serous sacs may be formed, either by the presence of attenuated bacilli in adjacent peritoneal surfaces and irritation of them, or by transudation of serum from veins constricted by bands or adhesions. This latter condition is seen when the abdomen is opened for the relief of intestinal strangulation caused by such a band.

By the organisation of the exuded fibrin into connective tissue the tubes may be bound down at the fimbriæ, or more extensively; or the two fimbriæ may cohere posteriorly. Thus they are in future, perhaps, unable to apply themselves to the site of the mature Graafian follicle; or one may be thus adherent, and the other, being free, may apply its fimbria to the other ovary on ovarian maturation.

The irritation produced by effusion from the fimbria of the tube causes a thickening of the tunic of the ovary by its inflammatory cell multiplication and condensation; if the peritonitis be more severe, the surface may be coated with exuded organised fibrin, which may form into bands, or be densely adherent to adjacent peritoneum. When the ripe Graafian follicle has advanced from within the ovary to this thickened and condensed surface layer, its further progress is thereby impeded; the liquor folliculi may increase in quantity beyond the normal, and a hæmorrhage take place into the cavity and so effect its rupture. The ovarian tunic may yield under this increased tension, when a fimbria may by its previous affections be unable to apply itself, and its abnormal contents may thus fall into the abdominal cavity. By the stress of such a follicle on the ovary an undue pressure on the ovarian stroma may create pain, and by the escape of the contents into the peritoneum a peritonitis be caused. The opening may be quite minute, or door-like and valvular by contact with the adjacent peritoneum, so that the fluid oozes out gradually; and, the irritation causing peritonitis being thus continuous, the temperature may remain high, though the inflammation be really confined to the locality of the effusion. Degrees of pyrexia in peritonitis seem often to be dependent on the degrees of mildness or virulence of the effusion, and on the excess of absorption over exudation. It is often high when the cause is mild, and absorption by the lymphatics into the system active; normal, when the effusion is virulent and peritonic exudation dominant; and low from debility and shock, if a large quantity of blood be poured into the peritoneum by rupture of vessels.

Such ruptures of different cysts may be consecutive, producing recurrent peritonitis; and should blood be present in the follicles, the irritation is the greater. Frequently rupture is not effected, and a follicular cyst remains which may be filled with blood; this is possibly more generally the case when the maturity of the follicle has been coincident with menstruation or sexual union. Such follicular cysts may attain to the size of a walnut, or occasionally larger than that; and, finally, as the gradual



increase of fluid thins and ruptures the walls, they may empty themselves into the peritoneum and produce peritonitis.

By the continuance of pressure of these cysts the ovarian stroma is permanently compressed and atrophied; and the ovary may be composed of little more than such sacs. This fluid may after a time be absorbed, when the ovary by contraction of the sac-walls will appear to be cirrhotic; but the outer walls of the cysts remain mainly as connective tissue condensations.

If in the earliest period of septic infection of the fimbria, which is usually puerperal, gonorrhœal, or tuberculous, its effusion have had time to effect a peritoneal exudation causing cohesion of the fimbria to the ovary, a free escape into the peritoneum may have been prevented, and the fimbria may have become adherent to a subsequently ripening Graafian follicle, which may rupture into the lumen of the tube: the septic matter may thus enter the cavity of the follicle, and lead to a septic abscess of the ovary; or bacteria may penetrate the thinned wall of the follicular cyst, which is inflamed by contact. The further progress of abscess of the ovary is described under section 6, as its causation is always bacillary.

When tubal disease of a moderate degree is in progress of recovery, extra-uterine foetation may occur. The disease may have arisen from endometritis, however caused; but specially from the virginal granular cervix or from a lacerated cervix, which may have been cured by operation; or it may have had a gonorrhœal origin, with attenuation of the bacteria under conditions of free uterine drainage. There has been stenosis of the uterine end of the tube, and perhaps some mild peritonitis from tubal distal effusion: in process of recovery this stenosis has been mitigated, but not completely removed, and the semen has been able to enter the tube and impregnate the ovum. If the outer part of the tube be sufficiently patent, the ovum may be able to advance to the portion within the uterine wall, where it may be stopped by the congestion of fecundation external to the site of the stenosis, and there develop as a tubo-uterine foetation. Should the site of the stenosis be more external the gestation is tubal.

In rupture of a tubal gestation more or less of the contents of the ovum, with blood from the torn chorionic villi, may be discharged through the fimbria and form tubal abortion; or through the lateral wall into the abdominal cavity, and produce peritoneal hæmatocele and peritonitis, of which the degree and progress will vary with the quantity of blood lost in relation to the bacilli of the original salpingitis, which probably escape with it from the tube external to the envelope of the ovum, and the subsequent necrosis of the ovum: or again into the broad ligament, forming a hæmatocele in its connective tissue, the blood forcing its way in the direction of least resistance, and perhaps suppurating under the influence of bacilli introduced from the tube, which may throughout have remained mildly septic from the original causation of its disease.

If the quantity of blood lost by such rupture be so slight that the

ovum survives, the subsequent condition is that of a compound abdominal pregnancy, with such relations of the placenta as are determined by its situation, either below the fœtus toward the floor of the pelvis or above it in the abdominal cavity.

The pressure of the enlarged tube or ovary may push the uterus over to the opposite side, effecting latero-version, from which there may be recovery on subsidence of the tumour. Or a peritonitic exudation from tubal or ovarian effusion, or a hæmatocele may similarly displace the uterus to the opposite side; but, on absorption and organisation, the uterine body may be drawn over by the condensed exudation and permanently retained on the affected side.

C. The hereditary constitutional defects, in which certain classes of cells morbidly proliferate, are dermoid tumour, parovarian cystoma, cystoma of Gärtner's tubes, ovarian cystoma, papilloma, myoma, sarcoma, and cancer.

By "Constitutional" is not meant that the disease will certainly or probably occur because of heredity, but that there is a constitutional capacity for such cell proliferations, should the parts be placed under suitable exciting causes. Thus, as to the development of cancer from the continuous irritation of a granular cervix, the latter may in some cases persist to the end of a long life and remain benign; in others, where there is a constitutional capacity of such cell degeneration, it readily becomes malignant.

The etiology of the dermoid tumour is attributable to the origin and mode of development of the ovary. From the mesothelial division of the mesoderm are formed the ovary and striated muscle; from the mesenchyma, which is the other division of the mesoderm, come the connective tissue, the heart and blood-vessels, lymphatics, smooth muscle, fat cells, and the skeleton. The dermal bones, which are those of the head and face, and are most frequent in dermoid cysts, are formed by direct ossification of connective tissue; they are homologous with the plates formed by the fusion of epidermal teeth, or of the so-called placoid scales which are true teeth developed in the skin and supported by a base of bone: of them there is the stage of scattered independent dermal teeth (dermoid scales); teeth-bearing plates formed by the fusion of the expanded bases of adjacent teeth (exo-skeleton); and membrane-bones developing without the appearance of teeth. (Minot.)

The mesothelial layer of the mesoderm is closely connected with the ectoderm; the mesenchyma with the entoderm.

From the ectoderm are developed epidermis and epidermal structures, such as hairs, nails, glands (sebaceous, sudorific, salivary, and mammary, the mammary being a hyper-development of the sebaceous), the eye, and the mouth-cavity with the teeth; all of which structures are occasionally found in the dermoid cyst. Thus in the formation of the dermoid ovum some mesenchymatous and ectodermal cells have by migration been incorporated with the mesothelial, and, continuing a constitutional abnormal growth, originate and produce the contents.

A projecting dermal bone may perforate the sac wall and produce peritonitis, whereby the adjacent structures cohere so that bones and other contents may escape through the bladder or intestine; but the sac probably inflames on the admission of bacteria.

After the period of vital activity and growth of the contents of the tumour, growth may cease by deficiency of nutrition, caused by bending of its vessels from the pressure of the tumour, or by the diminished size of the blood-vessels after the menopause; retrogression may then set in and pass through a stage of fatty degeneration, absorption, and calcareous transformation of the sac wall and its contents which may thus become atheromatous or calcareous. Crowding, by excessive local cell proliferation occluding small vessels, may produce necrosis of some part, as of a sebaceous gland, whereby suppuration within the sac may be induced; the pus may become foetid by transudation through inflamed distended adherent sac-intestinal walls, or by the direct admission of putrefactive germs from adjacent adherent perforated intestine, or by operative septic puncture. Or suppuration may proceed from the irritation, inflammation, rupture, and necrosis from excessive proliferation of a papilloma within the dermoid, either on the inner wall of the sac or on dermal plates: or by further cell degeneration cancer may ensue.

The parovarian cyst is caused by an embryonic deficiency of absorption, and a subsequent hypertrophic glandular secreting development of the granular cylindrical lining cells, which normally remain quiescent in the sexual part of the female rudimentary Wolffian ducts situated in the connective tissue of the broad ligaments. In the early embryonic state the future male is indistinguishable from the future female. In the male the developed epididymis is the analogue of the atrophied epoochoron or parovarium of the female. The epididymis is lined with columnar epithelium; and a continuation of this layer with secreting power, and deficiency of resorption or atrophy in relation to hypernutrition, originates the parovarian cystoma. It is probably a continuance of or a reversion to an embryonic or local hermaphroditic type. In its enlargement it parts the walls of the broad ligament, and spreads out upon its surface the Fallopian tube and fimbria, and later the ovary; it may extend deeply into the connective tissue layer of the pelvis, or on the uterus. As the cells lining the sac have but slight power of proliferation, probably from defective nutrition of a structure normally in arrest of development, the sac wall is very thin; and there is no ingrowth, for this is not the mode of its analogue, the epididymis, nor of antecedent phases: thus the cyst is unilocular, unless by cystic development of more tubules of the parovarium; and veins do not become varicose and rupture internally, unless by rotation of the pedicle, or their kinking under pressure of the tumour. For the same reason secondary growths, such as papilloma, which require local hypernutrition, are rare.

A cystic tumour situated laterally in the vagina may have its origin in a similar state of one of Gärtner's tubes, which are the lower parts of the atrophic Wolffian ducts, are the analogue of the male



adult spermiduct and vesiculæ seminales, and run through the genital cord.

As to the etiology of ovarian cystoma, in the development of the ovary portions of its external germinal columnar epithelium grow inwards, and some of these cells become ova; while deeper multiplied cells of the same description form the membrana granulosa of the Graafian follicles. The normal function of these cells is to conduce to the nutrition and further development of the ovum, which has the highest power of progressive development in the body. But it occasionally happens that the tendency to continuous proliferation of the cells of this layer is greater than the subserviency to perfection of growth of the ovum, and their multiplication is in excess. At the same time the inner cells rupture and pour their secretion internally; by such continuous process an ovarian cystoma is formed, which persistently enlarges. It is a constitutional degeneration into a glandular secreting structure.

As the cells of the germinal epithelium do not all arrive at the production of the complete Graafian follicle, but there are many less well-nourished primitive ova embedded in the stroma, it is possible that, while the better-nourished cells of the membrana granulosa are most apt to undergo this degeneration and the cystoma to be formed originally in a Graafian follicle, those in the stroma may also proliferate in a similar manner under the influence of the existing constitutional tendency.

In this growth, morbid in man, may be seen a strong analogy to the development of the ova and the yolk-food in some lower creatures. In them from the inner wall of the germinal plasma grow cells, usually columnar in character, which form (*a*) ova, or (*b*) germinal cell-nests; from among these one or more ova may be produced, while the rest of the cells serve as yolk-food and disintegrate. The number of ova in some creatures — as nine millions in the cod, three to six millions in the conger (7, 9), and seventy thousand in the woman — is frequently prodigious. The sac membrane may bud off internally, and form laminae and branches for further cell proliferation on their walls, and subdivision of the ovarian sac. These partitions may break down to permit extrusion of the ripe ova. Some creatures, as for instance the conger, breed only once, and die by the enormous distension of the body by accumulation of ova, which, in captivity, are incapable of escape. In ovarian cystoma the multiplication of cells thus closely simulates and is analogous to similar proliferation in lower creatures, either as primitive ova-cells, or as germinal cell-nests, undergoing progressive degeneration; and may be regarded as a morbid hypertrophic germ-plasma cell proliferation reversionary to an anterior type. Although children have been born with this disease, and occasional instances are found in the early years of life, when the condition may be regarded as one of defective development, it is most commonly found to commence during the years of strong generative ovic vitality; and many patients, nearly a third, are single. It is thus probable that ovarian cystoma is a degenerative reversionary proliferation of the germinal ovic epithelium (akin to that of the unstriped muscular and connee-



tive cells occurring in myoma), in relation to absence or deficiency of their normal employment, namely, the production of the next generation.

The degeneration being thus of a type which affects the development of all the cells of this class, the disease does not attack one follicle only, but is common to all; not necessarily at the commencement, but subsequently. Hence a cystoma, on its attainment of some size, is almost always multilocular; one sac may, however, by appropriation of the most nutrition, attain to the greatest size.

By ingrowths of the lining columnar cells a cyst may be divided, and by such repetitions it becomes additionally multilocular. By the thinning and rupture, or the necrosis of a partition by excessive pressure of the fluid on one or both sides respectively, two cysts may become one. By varicosity of veins induced by the pressure, which is frequently at the junction of the tumour with the pedicle, or by pressure of adjacent rapidly growing cysts on a vein, the rupture of a vein may occur; and one or more cysts in a multilocular tumour may be filled with blood. By similar partial pressure on the arteries and veins reducing nutrition, fatty, purulent, or calcareous degeneration of the lining cells and thus of the contents results, whether of one or more of the cysts.

By some kind of changing pressure, such as manipulation, descent of fæces, vigorous alteration of position, or tension of or pressure on the tumour as in lying, or by the growth of the pregnant uterus, or in parturition, or on removal of pressure as after parturition, or on change in form of the tumour, as by the emptying of a large cyst in a multilocular tumour by tapping, rotation of the tumour may take place, and the pedicle be twisted—an event which may similarly, by the same or similar causes, be many times repeated; thereby the vessels are liable to be occluded. Partial closure both of arteries and veins limits circulation and nutrition, and may materially restrict the development and growth of the tumour. But the circulation is less obstructed in the arteries than in the veins; whence may result ascites from serous effusion through the coats of the latter on the external wall of the tumour; or veins may rupture externally or internally, but in a limited degree for the tension is not severe. If externally, the blood coagulates between the sac wall and the adjacent peritoneum; these cohere, vessels form, and the venous return is thus facilitated, and the vitality of the tumour perhaps preserved. The adhesions prevent further rotation of the tumour, which may have been partial, so that the cyst may occupy a fixed position on the side opposite to its own. Such adhesions restrain the movements of intestine and omentum to which they may be attached; and varying degrees of obstruction to the passage of flatus and fæces may be produced: at a later stage stretched bands may tightly constrict the bowel, strangulating it, compressing the veins, and causing actual rupture or serous effusion from them into the abdominal cavity. The future growth may be slow, and is subject to these adhesions; and perhaps not till an advanced period of life are such results produced that the presence of the tumour is first discovered.

Should the veins be occluded by a more complete or more repeated rotation; an intense engorgement immediately occurs; veins on the interior of the cyst wall rupture, and the sac is filled with blood, whereby sudden enlargement and perhaps rupture of the sac take place; the abdominal cavity may then be filled with blood and ovarian fluid, and the woman faint or die. If there be venous rupture also on the outside of the sac, but without rupture of the sac, peritonitis and adhesions occur, which partly nourish this surface: the tension of the walls effects their necrosis; and by transudation of the necrosed fluids through the distended sac wall into the abdominal cavity an acute or chronic peritonitis will result proportionate to the predominance of absorption or exudation: these factors are determined by the quality and quantity of the fluid transuding, and by the degree of internal tension.

If the arteries and veins be closed at once by the compression of a twist, no more blood enters the tumour, and it tends to necrose by lack of nutrition. As it necroses, transudation of its fluids produces peritonitis, and fibrin is exuded which, by its development of vessels, may effect such a nutrition as to maintain just so much vitality of its surface cells that a slow absorption occurs; the tumour decreases in size, and remains in a stagnant condition. Such complete closure of arteries is rare in comparison with that of veins, as these are more readily compressed by an earlier rotation.

By a continuous pressure on a bony angle—as on the sacral promontory—of a tumour of which a part occupies the sacral cavity, and part of the abdominal cavity, there may be by limitation of circulation a thinning of the sac wall at this site which may result in necrosis; rupture may occur, and the fluid escape into the abdominal cavity. The same result may follow extreme distension from venous rupture due to a twisted pedicle, or from a sudden blow, or fall. If the fluid itself be bland the resulting peritonitis may be slight, but more or less progressive according to its quality and quantity, and the degree of infecting necrosis which may presently occur in the ragged edges of the torn wall, combined with the influence of systemic depression and abdominal pressure effected by the hæmorrhage from vessels which may also be torn.

A further degenerative cell multiplication may induce papilloma; and one still lower, cancer, with peritonitis by invasion, hæmorrhage and serous effusion into the peritoneum.

Papilloma of the genital organs—which is a progressive multiple development of ectodermal or entodermal epithelium, enclosing a vascular loop formed of a capillary terminating in a small vein and thus forming a papilla—is liable to be produced by an irritation which induces an increased growth in any part of the genital organs. About the vulva the cause may be the irritation of syphilitic discharge; at the orifice of the urethra, of the friction of coition or masturbation, or exposed urethral membrane; in the bladder, of urinary crystals or decomposition; in the vagina, occasionally, the hypernutrition of pregnancy; and in other parts of the genital organs—as in the uterus, tubes, ovaries, and

in their tumours and peritoneal coverings — papilloma may arise from local irritation and vascular proliferation. In connection with all internal papillomas the veins are liable to be large and varicose by direct pressure or bending on the cardiac side. When occurring on the internal aspect of a cyst, by complete local venous obstruction, or perhaps from deeper excessive cell proliferation, papilloma may undergo limited necrosis and thus suppurate. On the peritoneum, friction of its delicate structures usually produces serous effusion, and perhaps hæmorrhage, into the abdominal cavity.

Myoma, which is a proliferation of unstriated muscular fibres enclosed in a connective tissue capsule, and usually multiple, is attributable to absence of pregnancy, from whatever cause, in a woman of strong sexual development: the nutrition, which should be absorbed in the development of the pregnant uterus and fœtus, is expended in the morbid local proliferation of muscular fibres.

While the muscular fibre proliferation has proceeded a sac has been formed also, usually by a similar multiplication of connective tissue cells, which surrounds the myoma, enlarges with the progress of the muscle fibres, and yet maintains such strength as continually to constrict the supplying vessels and retard the growth. Yet this is not necessarily the case; for occasionally a myoma rapidly grows in the absence of synchronous connective sac development, and has the exact form and red appearance of the pregnant uterus; and, in the oedematous myoma, the rapid enlargement by serous or lymphatic infiltration of the inner structures so distends and softens the sac that its density is diminished. In the former unrestricted form is seen the more exact tendency toward the pure uterine growth of pregnancy, though the stimulation of the ovum is absent.

The effects of such diseases depend upon the situation of the original fecundity of the muscular growth, and thus of the direction of increase and prominence of the tumour. If such situation be nearer the endometrium the direction of least resistance is toward the cavity of the uterus, and the tendency is to the polypoid form; by recurrent rotation due to muscular contraction, a long thin pedicle may be formed, the vessels of which by such continuous pressure may become occluded, and the polypus die and become septic; or muscular contraction may expel the polypus into the vagina. If more central the tumour is interstitial. If in the external part of the muscular wall it grows outwards; when also the pedicle may gradually be lengthened, thinned, and composed only of vessels covered with peritoneum: or it may be divided, either by the drag of its impaction in the pelvis while the myomatous body grows upwards, or by compression of the pedicle against the sacral promontory, or again by rotation of the subperitoneal tumour. The pelvic tumour thus separated may either undergo a vital degeneration by the encroachment of connective tissue adhesions resulting from the peritonitis induced in the process of the occlusion of the vessels of the pedicle; or may necrose, inducing peritonitis and septic absorption.

By cessation of arterial supply, produced by pressure on the vessels

by the tension of the connective tissue capsule of the tumour, generally interstitial, the central cells may be so deprived of nutrition that they necrose; if the nutrition be deficient, but still exist to some degree, a degeneration, fatty, purulent, or calcareous, may occur. If the veins be partially compressed at some point, or in the progress of growth of the tumour be kinked, the distal parts become varicose, and the tumour from which they are efferent may become œdematous. Cysts may also be formed by the rupture of veins from a similar cause into the myomatous substance, when the cavities thus formed may be found to contain blood; or, later, after absorption of the colouring matter, a straw-coloured fluid. By occlusion of the veins of the uterine cavity by pressure of a submucous or encroaching interstitial myoma their walls may rupture, and hæmorrhage, called menorrhagia, result: this is particularly apt to occur at the menstrual epoch, when the veins are specially engorged; but it may be continuous, in relation to the continued pressure; or recurrent, when the blood has been reformed: in the intervals fibrin may escape, which may be coagulated or not. With this there may be intense dysmenorrhœa from the small size of the external uterine opening, which latter, indeed, may have been the original cause of the sterility, and so of the myoma.

By similar obstruction to lymphatics, so that their spaces dilate and may become of considerable size, the tumour is rendered myomato-cystic; through rupture of the cyst walls large yellowish coagulated clots of their secretion may escape by the uterine canal. Thus in the same specimen may be found an œdematous as well as a hard myoma, the condition of either being dependent on the individual relation to obstructed veins or lymphatics, or both.

Suppuration may follow septic puncture.

The encroachment of myoma in direct growth, or combined with artificial abdominal pressure, by bending the uterine ends of the Fallopian tubes, frequently occludes them, so that the secretions cannot escape along the genital canal. Tubal distension then occurs, and there is presently some effusion at the fimbriæ, whereby is produced a peritonitis proportionate to the quantity and quality of the effused fluid. Fibrin may be thus exuded, and such adhesions formed as bind down the fimbriæ and occlude this extremity; thus the mid-tube may become dilated by subsequent collection. Should the tube be septic or gonorrhœal, the further progress is that of pyosalpinx, which, by rupture, may cause a fatal peritonitis. Or, the tumour in its growth may spread out, elongate, and flatten the tubes, and render the fimbriæ œdematous: a frequent local peritonitis may occur from their congestion and effusion.

Myoma frequently and when of any size usually compresses the ovaries, so that they perform their functions with difficulty; and local peritonitis occurs by the rupture of the irritated Graafian follicles into the peritoneum, since on account of the pressure the tubes cannot apply themselves. As their tunics have previously become thickened by the peritonitis induced by the fimbrial effusion above described, as well as



by that resulting from their own rupture, the follicles presently fail to rupture, and follicular cysts are produced, which undergo further evolutionary changes. The continuous degenerative irritation may induce malignant disease, which indeed is particularly liable to originate in the endometrial glands.

Myoma may occur in the ovary, by similar lack in sterile women of normal utilisation of blood; and an excessive development of connective and fibrous cells may produce a fibroma of the uterus or ovary.

Sarcoma, originating in connective tissue derived from the mesoderm, has as its cause the constitutional tendency to multiplication of embryonic connective fibre cells; when of the ovary, it is perhaps a morbid reversion to a lower type in the direction of the formation of ovarian laminae, which have not the capacity of development into the higher connective tissue structure: there is proliferation without organisation. The ovary is occasionally, though rarely, thus affected, and apparently in relation to sterility.

Cancer, which is a continuous cell proliferation of amœboid type invading the lymphatic spaces and vessels, and always originating in epithelium derived from the ectoderm or entoderm, has its cause in such conditions as induce excessive formation of cells of degenerating quality. Should the constitutional state permit such degeneration to descend to the lowest amœboid type, constant multiplication takes the place of evolution; and this tendency is exaggerated by the occurrence of obsolescence, and therefore of defective nutrition of these organs, at the most common period of cancerous development; namely, at or about the menopause. Such sites and conditions are exceedingly common in the chronic granular hyperplastic face of the lacerated cervix, in which, unless healed by operation, cell proliferation terminates only with life; and the cancerous degeneration is possible at any time. In endometritis the same chronic glandular irritation may persist; and ensuing malignant disease occur but a few months after parturition in young women from hypernutrition and excessive cell proliferation with degeneration at the placental site from puerperal deciduoma; changes which may be associated with frequent hæmorrhages, leucorrhœa, subinvolution, and constitutional tendency to cell multiplication of rapidly descending cell type. Or the cancerous phase may be delayed in less feeble capacity of cell organisation, but be attained by a slower yet progressive exhaustion through the same constant drain on the system. But cancer is less frequent in the body of the uterus, a part which is not exposed to the friction against the vagina, a friction which irritates the granular cervical face, and thus increases cell production. Nor does it occur on the granular laceration of the prolapsed cervix, because cell proliferation there is greatly limited by the dryness of the situation.

The continued irritation of a myoma may produce a constant proliferation of a primary or embryonic type. Should this occur in the connective tissue element a sarcoma of the round-celled variety is produced; if in the musculo-connective tissue the sarcoma is spindle-celled;

if in the glandular structures of the endometrium a cylindrical-celled epithelioma may arise.

By the invasion of the lymphatic vessels, and pressure on veins by the excessive multiplication of cells, œdema and local hæmorrhage result. The continuous increase presently so occludes the arteries that central necrosis is produced; at the periphery of this the open ends of the vessels may bleed extensively from inability of their muscular layer, which is infiltrated by the cancerous cells, to contract. Nature's endeavour to separate the slough towards the outer edge of the continuous low cell proliferation — a proliferation too degraded in character to form healing granulations — when retained in healthy passages, as in the vagina, results in a dirty fœtid discharge, which is in some degree absorbed; thus, and by hæmorrhage, the system is drained, enfeebled, and poisoned.

The excessive cell proliferation, around the nerves as well as in the substance of them, effects such compression of them that intense agony ensues; this is worse at night, either because the recumbent position increases the weight on the nerves, or because the nervous system, at this time exhausted by the waste during the day, is less resistant to the propagation of the diseased actions. This pain is usually referred to the lumbar region at the site of the entrance of the vaginal and pelvic plexus to the spinal cord.

The pressure of the tumour on the adjacent bladder and rectum may impede the passage of their excretions, and thus abdominal distension by gas and retention of fœces may affect the appetite and digestion.

Extension of the disease to the peritoneum by local irritation produces peritonitis, by interstitial cell proliferation it produces venous compression and serous effusion, and, by arterial obstruction, necrosis, rupture of vessels into the peritoneum, and thus increased temperature. The advance of the growth into adjacent organs, as into the rectum or intestines, by narrowing them, may produce obstruction; and subsequently, with or without obstruction of them or of the bladder, necrosis of the cancerous structure may occur, and the contents of the viscus may be discharged through an open sloughing hole. Further extension through the lymphatics and veins effects the transference of malignant cells to other more distant organs, which there become the foci of fresh similar growths; thus by continuous excessive cell proliferation, necrosis, septic absorption, hæmorrhage, serous discharge and pain, the system is finally exhausted.

**II. The conditions too often incident to the education of the mind** may materially and injuriously affect the physique of women in civilised life. For six, eight, or more hours a day during eight or nine months in the year, the girl is in a room indoors where are many others, so that the air is frequently impure. The arms and legs are at rest, and in cold weather are chilled and the circulation impeded, so that chilblains, even where there are no frosts, are common. The stooping posture over desk or book, in drawing or at the piano, produces one general curve of the vertebral column instead of the normal three upper compensating smaller curves; and frequently, by fatigue, weariness, or defective eyesight, some

lateral curvature is established. There is an increased attraction of blood to the brain, and great call upon the mental powers. Exercise is neglected, and may consist of a constitutional walk in pairs, a mode which is foreign to the natural habits of young people; thus there is long physical repose and merely formal exercise at an age of naturally almost constant, free, untrammelled play and muscular activity. Personal competition, culminating in place examinations, may favour the egoistic temperament instead of the altruistic, instead, that is, of the care for others, as of the next generation, which normally is a strong feminine characteristic. In large public schools for both sexes the close association of young people may induce an injurious sexual knowledge and desire, conscious or unconscious, without the opportunity of lawful or moral satisfaction.

But the individual type must dominate all such educational habits, however it may be thereby modified; and it must always be remembered that the strongest instinct in woman is the sexual — not necessarily the sexual appetite, but the production of the next generation; thus there may be strong or feeble sexual development with a feeble or strong physique; in either case with high or only moderate mental attainment.

The general effect of the educational course then may be to develop mental at the expense of physical power, and especially of the muscular power, and the strength of the vertebral column; by diminished demand on the elements of nutrition, to reduce the appetite and the powers of digestion, and thus the quality of the blood; and to favour constipation, fæcal absorption, anæmia, and irritable and hypersensitive nerves. The important function of menstruation is thus readily deranged; and irregularities, such as menorrhagia by deficiency of coagulation, or of strength of the veins in the strongly sexually formed, or amenorrhœa in feebly developed sexual organs, arise; and, if the mind be of the artistic or æsthetic kind and non-passionate, the sexual organs fall in some degree into abeyance, and may subsequently remain feeble; there may be disgust at marital rites, and a tendency to hereditary sexual degeneration.

**III. Personal Habits.** — There is no such care taken by us at the menstrual epochs as among some other races, where the women seclude themselves, so that the function is quietly performed. With us it is not unusual for a woman to inject cold water or to take a cold bath to stop the flow for social or sexual purposes. The feet, clad in thin shoes, often become damp and remain so, and in cold seasons are habitually chilled through the soles. The evaporation of perspiration in cotton under-clothing abstracts much heat from the body and chills it, and the legs are but little protected from cold winds.

Any of the above causes may produce contractions of the superficial vessels, with engorgement of the deeper, thus throwing on the latter the necessity of reactionary contraction, which they may be unable to perform. An unequal state of blood-supply thus occurs in the body, and the defending army of phagocytes and leucocytes may be unable successfully to combat attacking bacilli, whose victory is proclaimed in the

statement that a cold has been taken, a cold which may be the beginning or further bacillary successes in this enfeebled condition. Or the deeper vessels may be unable to bear the undue strain of such engorgement, and their coats yield, producing hæmorrhage or hæmatocele; or again, irregular contraction of muscular fibres, as of the Fallopian tubes, may occur, so that their secretions, mucous or menstrual, may effuse from the fimbriae, and peritonitis result—in this case probably in connection with some lower uterine stenosis.

In the case of vaginal injection of cold or very hot water during menstruation a similar local vascular contraction may be induced without subsequent reaction, and the flow may cease; this sudden shock may subsequently induce such a local depression of the circulation that the ovic maturation and catamenial discharge may cease for a long period, and the system suffer from the local anæmia and functional arrest.

But of all injurious influences to woman, to which is attributable the great mass of the disease now so prevalent, is the extraordinary custom of the alteration of the form of the body, and of the position and relations of the internal organs, by the almost universal custom of compression of the lower thorax and abdomen; were this done to animals, we should recognise its amazing injury and absurdity. The busk is a very powerful lever—the power of which woman does not understand; by it she always compresses her body from 1 to 3 inches; and frequently, especially when stout, and therefore more subject to the injurious influences of compression, 4 to 6 inches. The dress is similarly tight, and usually cannot be fastened unless the stays have effected previous compression.

The influence is markedly accentuated by the attachment of the skirts and petticoats around the waist and abdomen which have to support them. These usually weigh from four to six or eight pounds, and react especially on the organs of the abdomen and pelvis.

Such compression affects the muscles, and invariably displaces the organs of the body to an extent proportionate to the degree of pressure.

The traction force required to approximate the busks in a natural separation of from

1 to 2 inches is from	8 to 20 lbs.
2 to 3    "        "	20 to 40   "
3 to 4    "        "	40 to 60   "
4 to 5    "        "	60 to 80   "
5 to 6    "        "	70 to 90   "

I am informed that the compression thus exerted on the body is represented by half these weights. Thus a woman who draws in her stays from 3 to 4 inches, a very common custom, places herself under a direct pressure of from twenty to thirty pounds weight. But this does not allow for the extra pressure produced in drawing a deep breath, when the approximated busks, under even the heaviest of the above weights, will readily part from half an inch to an inch. This, however, is impossible when the busks are fastened, and this additional pressure



also is therefore exerted directly downwards on the pelvic organs. There is additional increase of pressure by the weight of the skirts and petticoats, and by food or liquid taken into the stomach; when intestinal gas forms from induced indigestion, the condition is thereby accentuated.

The spinal column is placed in splints upon which it tends to rely, and its movements are limited; the muscles, therefore, atrophy by deficient use, so that the woman says her back would break if she did not wear them. By the bending of the back in her education, and the wasting of the muscles by the wearing of stays, the normal curves of the spine are frequently lost and abnormal curvatures induced. The general strength of the body is thus reduced. Similarly, the pressure on the abdomen forces down the intestines, stretches the lower abdominal wall, and renders its muscles atrophic; hence an important reduction of reflex and voluntary muscular power in labour. The compression of the lower ribs forces up the diaphragm, squeezes the lungs, and displaces the heart, so that fainting from this cause is not uncommon. The kidneys are affected proportionately to the degree in which the lower ribs approach the iliac crest. If the ribs be high, their indentation on the upper half of the kidney displaces it downwards, stretching the connective tissue which attaches it in its bed of fat; it is then said to be movable; and, from the variable pressures to which it is subjected in the wearing and non-wearing of the stays, it is apt to be painful: the right kidney, being usually the lower, is most frequently thus displaced. The liver is flattened by the ribs, perhaps indented by their edges, and often extends to the level of the umbilicus; the bile ducts are compressed, and constipation and, occasionally, jaundice result. The stomach is so squeezed that, when food is taken after the stays have been put on, there is no opportunity for its normal enlargement thereby, nor for the long process of churning essential to normal digestion; thus the food is passed on into the intestines in a partially digested form; dyspepsia follows, and a tendency to ulcer of the stomach by vascular stasis due to the long-continued pressure. The small intestines are depressed, and receive the ingesta in an abnormal state; so that putrefactive changes occur in them, which produce flatulence and distension; compression about the ilio-caecal valve influences appendicitis. The transverse colon is forced downwards, tending to produce obstructing angles at its junction with the ascending and descending portions, which are depressed; and thus impairment of the peristaltic movements, flatulence, and constipation ensue. The rectum is compressed by the pelvic contents, so that the faeces tend to be unduly retained. Thus it comes about that digestion is impaired, flatulence arises, constipation is produced, the moisture of the faeces is absorbed, the blood is depreciated in quality and rendered impure, nutrition of the body falls, and the muscular force is reduced; the teeth become carious, which reacts on the digestive functions; the nerves are debilitated, and neuralgias ensue; menstruation is disordered, and the general evils of anaemia result; the capacity of the bladder is reduced, rendering micturition frequent, and subsequently

often painful and necessitous. If the uterus be strong, and the bladder not subject to much distension, relieved perhaps by frequent micturition set up by crowding of the parts, the pressure of the intestines forces its body forwards and downwards into a horizontal position, and the cervix is apt to follow the anterior course of the body, the whole organ rotating forwards on a transverse axis, so that it is anteverted; thus the body unduly presses on the bladder, and additionally irritates it, while the face of the cervix is subject to friction on movement against the posterior vaginal fornix, when there is aggravation of the virginal granular face, previously described, and degenerative diseases often ensue. Or, perhaps by rectal accumulation, the cervix is pushed forwards, more often into the perpendicular position, and anteflexion results. If the uterus be of feeble development the body has already fallen forwards; but, by the pressure, the condition of anteflexion is accentuated.

Or a strongly developed uterus may be unduly retroposed by the flattening from above of the bladder; the forcing down of intestines into the pelvis tends to depress it into a lower pelvic plane, and the usual retention of fæces in the rectum presses the cervix forwards, inducing a rotation of the strong uterus backwards on a transverse axis at the junction of the cervix with the body; thus the retroversion is completed. The virgin uterus rarely proceeds further, because of the strength of its posterior wall; but in the parous, if subinvolted ligaments and connective tissue permit the rotation to proceed, the uterine body may descend to a much lower plane of the pelvis, so that the fundus presents downwards and backwards; and, if the organ be of strong construction, the pelvis capacious and the vaginal structures subinvolted, the cervix may maintain its normal line with the body of the uterus, and the os present upwards and forwards toward the anterior vaginal fornix — the extremest possible condition of retroversion.

Or, instead of the continuance of the normal relative continuity of direction of the body and cervix of the organ, from its subinvolution and consequent flabbiness of tissue and pelvic resistance to the rising of the cervix, an angle of flexion at the cervico-corporeal junction, or even somewhat higher, may be formed, and retroflexion ensues, the body being perhaps horizontal and the cervix perpendicular. A further stage is attained when the body and fundus descend lower, so that the body and cervix tend to become parallel; this is the more induced and accentuated by the continued abdominal pressure on the convexity of the angle of flexion, so that their impaction in the pelvis results from extreme retroflexion.

The Fallopian tubes are liable to be bent at their junction with the uterus by the misplacement of the uterus in combination with pressure downwards of the intestines by the stays and dress. Thus in the sexual engorgement in love-making, with or without union, in women of warm appetite, this abnormal relation of the tubes to the uterus may induce effusion of their secretions into the peritoneum, particularly during menstruation, and a local peritonitis; otherwise, they would pass in the normal direction through the genital canal.

The ovaries are depressed, and forced into a latero-posterior position, carrying the fimbriæ with them by the attachment of the tubo-ovarian fimbria. Thus, by the pressure of the ovaries, the fimbriæ may be flattened, rendered œdematous, and unable to apply themselves to the Graafian follicles; these discharge into the peritoneum, and may, by a valve-like opening occurring from the compression, produce a recurrent peritonitis of some severity.

In pregnancy the stays are often worn very tight so as to conceal the condition; thus miscarriages and premature confinements may be brought about by the accentuation of the normal rhythmic uterine contractions, by induced dilatation of a previously lacerated cervix, or by rupture of the membranes. By pressure on the abdominal veins by depression, or repression on the vena cava of the pregnant uterus, varicose veins are induced, the legs and vulva become œdematous, the veins may rupture, and vulvar or pelvic hæmatocele be produced.

The pressure on the foetus may alter its presentation; pressure on the uterus may enfeeble its structure, as well as that of the accessory muscles of labour, which may be thus ineffective; forceps are now applied in the women's hospital in Melbourne once in nine confinements of all cases, and in private much more frequently.

There is such a forcing downwards of the uterus on the ligaments as must tend to stretch them, and render depression of the uterus to a lower pelvic plane and axis more ready after labour, leading to subinvolution, misplacements, and prolapse.

Thus by the wearing of tight stays the whole system of the woman is enfeebled, the pelvic sexual organs are apt to be misplaced, and the basis is laid for that evolutionary disease and sterility which are now so common.

Another mode of injury by compression is the use of the tight binder after labour. No doubt that a very firm pressure on the body of the uterus is, in civilisation, frequently necessary immediately after the end of the third stage, in order to prevent or stop post-partum hæmorrhage, common from the above-mentioned causes; but in a couple of hours after the cessation of the hæmorrhage this danger is past, when binder pressure becomes injurious without compensating advantage.

After the passage of the child the walls of the cervix for a time commonly lie in a state of muscular relaxation, so that an excessive abdominal pressure tends to evert the internal cervical or endometrial structure through the cervical opening. Very much more is this the case when the cervix has been lacerated, whereof the only satisfactory mode of healing is by first intention; to this result eversion must be fatal. To such a cause, which also bends the uterine veins, is often due the prolongation of the red lochia; and by the irritation of tension on the angles of lacerations deep into the vaginal junction, an inflammation of the connective tissue of the broad ligament ensues, which might otherwise have healed by a primary and softer union. The undue pressure, too, on the tubes thus crushed between the large uterus and

the pelvis may induce an effusion from the fimbriæ which may cause a peritonitis, perhaps of mild character, but sufficient to induce an exudation of fibrin, which may bind down the appendages and uterus.

The ligaments of the uterus are maintained in a state of tension; the relation of the veins, which are of great size, is altered, and the circulation through them to some extent obstructed, perhaps inducing thrombosis; the uterus is unduly congested, and its involution impeded. On diminution in size of the uterus, so that it regains a position in the pelvis, it is still large; the subsequent pressure by the stays and the perpendicular position of the woman depress it into a lower plane and more perpendicular axis of the pelvis, and into the state of retroflexion, as previously described. Thus under the influence of a continuous tight binder and subsequent tight stays the condition presently found may be one of deep laceration with everted granular faces, perhaps some connective cicatricial thickening in one or other broad ligament, subinvolution and retroflexion of the uterus, perhaps with such adhesions as bind it down. Such influence may also affect the column of the vagina and its connective tissue, and extend to the vulva and perineum, rendering them also subinvolted.

The large abdomen of the parous is frequently due to the predisposing influences of the unnatural habits before mentioned, which create a disposition to undue flatulent distension of the intestines; this, combined with the pressure on the waist by the petticoats and skirts, farther forces down the lax abdominal walls, and accentuates the gaseous distension. These causes are aided by that excessive fat in the abdominal walls which results from deficient exercise and work.

The application of a tight binder which depresses the uterus is distinct from a well-regulated bandage which serves normally to support the abdominal walls.

The conditions present to those who give themselves to the life of society are that they expose their necks to the suddenly varying temperatures of heated ball-rooms, corridors, verandahs, and gardens; they wear their dresses exceptionally tight; healthy exercise is usually deficient, but there is over-exertion; from the great and almost constant excitement there are undue nerve tension, and, not seldom, disappointments; the diet is irregular, and dainties are preferred; the hours are late; sleep is irregular, and taken at abnormal hours; repose of body and mind are deficient.

The effects are apt to be that colds are taken, and are with difficulty shaken off; the appetite is impaired, digestion enfeebled, and constipation established; the formation of the blood is injured, anæmia and general debility ensue; the catamenia become irregular; the nerves are impoverished, so that neuralgias and hysteria arise, and the weight declines. Such parous women are apt to suffer from subinvolution with endometritis and its consequences for reasons previously mentioned; and the milk is liable to be deficient in quantity, or of excessive quantity and of feeble quality, so that the systems of both mother and child are impoverished.

The diets that act injuriously are the defective and the unfit. It is



common among young girls of delicate constitution and temperament to have an apparent pleasure in refusing plain healthy food, or a necessary quantity of any kind. Thus some will take no breakfast, or only a glass of water; milk and meat are refused; and this refusal appears to become a point of honour. Single women from thirty-five to forty-five years of age, and women upon whom is a great drain of child-bearing and lactation, may similarly decline animal food.

The improper diets among young girls may include eating unripe fruits in place of ordinary food; or pastry, cakes, and sweets at irregular hours. Older women, especially in warm climates, frequently drink large quantities of very hot strong tea, or of water. All such aberrant diets tend to dyspepsia, flatulence, constipation, anæmia, and amenorrhœa; and in the parous also to subinvolution with endometritis, and their consequences.

**IV.** The influence of **absence of marriage, and late marriage**, which are the tendencies of our age; and of ineffective marriage, which includes artificial prevention of pregnancy, are highly deleterious. The due age of marriage certainly varies according to climate, and in that of Great Britain the perfection of development is from twenty-three to thirty; but at the age of thirty half the women are yet unmarried, so that about half of the period of their capacity of propagation has already passed. While many women in civilised communities are signally deficient in sexual appetite, many are normally developed in this respect. Such due appetite may be strongly present in girls of plain features, who are unattractive, ill-nourished, and depressed; and it is perhaps particularly in these that a normal temporary congestion and unsatisfied desire lead to injurious habits which produce chronic congestion, endometritis, and the like.

The common effect on the physique of postponing marriage is to induce a general atrophy; the fat, which imparts the rounded outline to woman, falls away and she becomes angular, her muscles and tendons are distinctly outlined, and markedly noticeable about the face and neck; the quality of the blood has suffered, and anæmia may have resulted; the nutrition of the nerves has been impoverished, and neuralgias and hysteria are common; the catamenia may have become irregular, and be either increased or diminished according to the temperament; and leucorrhœa may have resulted from desire unsatisfied by marriage or pregnancy. Some women who have a good sexual formation, except for a small external uterine opening and deficiency of sexual appetite, grow fat, the catamenia decrease, and the organs atrophy from absence of employment.

But the influence of the normal impulse to the production of the next generation is amply demonstrated in sexually well-developed persons who from non-marriage have not become pregnant; or who, from whatever cause, have ceased for a long time to bear children; by the frequent occurrence in such persons of myoma of the uterus: in myoma the muscular fibres increase in many sites in an irregular manner, which, in multiplication, is analogous to that of pregnancy; indeed, in an early stage its further development may be stopped by pregnancy, for the uterus

has thus been employed naturally, and its nutrition engaged in its proper functions.

**V. Sexual Exhaustion.** — Under normal circumstances in healthy women, coitus, though at first on marriage liable to be excessive, is usually limited presently by custom, and pregnancy ensues. Some husbands, and some women also, have an insatiable sexual appetite. Thus on the part of the man the act may be repeated very frequently; or the woman may be subject to many men, as are prostitutes; or unnatural habits may be adopted; or pregnancy may be avoided, with consequent absence of satisfaction, and thus of relaxation. All these conditions are liable to cause a chronic congestion, resulting in endometritis; or, in case of pregnancy, in miscarriage or premature confinement with succeeding subinvolution and endometritis: the induction of miscarriage, which is now so common, has the same effects. The frequent strain produces debility, and the nervous system is weakened.

Regular child-bearing with a normal condition of the uterus and moderate lactation seldom injures the woman; but when, combined with granular cervix and endometritis, the system is debilitated by the undue drain of excessive cell formation, disease is apt to ensue.

The child-bearing which would be healthily effected in a temperate climate is excessive to the British race in tropical countries, in which the blood becomes thinner and the vessels dilated; then post-partum hæmorrhage, subinvolution, endometritis, menorrhagia and anæmia are common.

The congestive thickening of the vaginal membrane near its posterior commissure from excessive coition may produce occlusion or stenosis of one or other vulvo-vaginal duct; the secretion accumulating in the more dilated part near the gland may continue clear, and a cyst be formed; or, if septic germs gain admission by the duct or through the blood, suppuration occurs.

**VI. Infectious Diseases.** — Syphilis is said not to be conveyed to the fœtus through the placenta, but through the germ or sperm. The fœtus is liable to be affected in the congenital form when one or both of the parents is actively diseased in the second stage at the time of impregnation; after conception the father, who may have been free from symptoms for many months, may suffer from a syphilitic testicle, or the mother from a rash; or, after a period of apparent health for perhaps twenty or thirty years, a parent may have a specific rash. The degree to which the progeny is liable to be affected is in proportion to the virulence, attenuation, or quiescence of the parental disease.

The effects are seen in hereditary congenital and simple forms. In the former, malformations, from inflammatory arrest or deficiencies of development, are present at birth, being induced by an inflammatory action in the cells, ducts, or vessels, destroying or closing them, and arresting development. In the latter the results, similarly caused, may not manifest themselves for varying periods after birth.

The mother may, however, directly transmit measles, scarlatina, and

small-pox to the fœtus, perhaps through the liquor amnii, and the same results ensue (Hamilton).

Syphilis, by irritation of its secretions, produces condylomata about the vulva and anus, and enlargement of the inguinal glands, with the consecutive affections.

The inflammation of mucous membranes, accompanying such diseases as scarlatina and measles in which micrococci have been found, may attack the vagina, uterus, and tubes; and, since the outlets are of small size during childhood, it may continue in a chronic form, and lead to evolutionary affections of the peritoneum and ovaries.

To gonorrhœa is to be ascribed a series of progressive diseases, which are liable to be as virulent as they are continuous.

Miserable to relate, this disease is met with even among little girls.

A young girl may, primarily, take it from a man who had the idea that his gonorrhœa was curable by contact of a young virgin; and she may convey it to others by the fingers. It may possibly be contracted by other means, as by contact of the vulva with gonorrhœa-infected towels, closet-seats, or chamber utensils; but, whatever the sex or age of the patient, there has been direct contact with the discharge of a previously diseased person. These young girls, perhaps but of a few years of age, may retain the disease for many months or even years, during which it is liable to advance into the higher genital organs, and produce evolutionary results. In this way it may be a common cause of the peritonitis of female childhood, and of adhesion and arrest of development of the genital organs, perhaps with their displacement; of the latter results, a small adherent retroverted uterus and adherent atrophic ovaries may be subsequently apparent as having occurred during the years of childhood.

The vagina is, primarily, not readily subject to the affection, an immunity probably due to the absence of glands in which the microbe may find a nidus. Thus the gonococcus at first finds a habitation in the mucous follicles at the orifice of the urethra or vagina, or in the sinuosities of the uterine cervical glands. When thus affecting the urethra an irritation arises, which induces a cell proliferation suitable for successful attack by streptococcus and staphylococcus present in the infecting matter: thus suppuration results, which, in combination with the gonococcus, travels up the urethra to the bladder; hence follows cystitis. Should entrance to the ureters be effected their inflammation ensues; and by subsequent contraction in healing, their stricture and hydro-nephrosis. If progressive to the kidneys, their inflammation, and perhaps suppuration, leads to pyonephrosis.

Also, the canals of the vulvo-vaginal glands may likewise be primarily affected by the gonorrhœal infecting matter, and abscess in them occur. The vagina is thus continuously exposed to the disease, and becomes infected; and presently, especially if the os uteri gape, the cervical canal.

Or the gonorrhœal matter may, in union, be directly injected into the canal of the cervix, and take up a habitation in the gland-ducts; and the

vagina be secondarily infected by the downward passage of thus diseased secretions. From the cervix the corporeal endometrium is affected, and the micrococci may infest the sinuosities of its gland-tubes. Thus, should the vagina, vulva, and urinary canal have recovered from the disease, perhaps by treatment, a later downward passage of the gonococci may again infect the vagina; hence vaginal recurrence.

The trumpet-mouth of the Fallopian tubes renders it easy for the germs to enter and infect them; hence salpingitis, and the evolutionary affections of the peritoneum and ovaries described in detail in section I.

When the fimbria of a tube infected by gonorrhœa, puerperal septicæmia, or tuberculosis is adherent to an ovary of which a Graafian follicle ripens and bursts into it, the bacteria enter the follicle and suppuration ensues therein; or when an accumulation of pus occurs in the fimbria adherent to the inflamed, distended, thin membrane of a follicular cyst, the bacteria may enter it by transudation. Septic pus having formed in a sac of an ovary, similar abscesses occur in other follicles, probably by transudation of bacteria under similar conditions; so that abscess of the ovary is usually multiple, though the septa between pus-sacs may break down and one large abscess predominate over the others, and the ovary becomes of considerable size.

On increase of pus the tunic yields in the direction of least resistance; and, as in pyosalpinx, on minute rupture peritonitis results, causing cohesion of the ovary with adjacent peritoneum, if this had not taken place previously. Should the attachment be to the intestine, the pus of the rupturing sac escapes into it; but the other sacs of the multilocular abscess do not thus discharge their contents, and the inflammatory condition continues. The cause of abscess of one ovary may also apply to the other, and thus both may suppurate; and, since the tubes were previously similarly affected, double pyosalpinx is probably also present: ovarian suppuration, however, being dependent on rare relations and opportunities, seldom occurs.

Septicæmia is a term applied to a class of diseases induced primarily by the entrance of putrefactive liquids into the system through the blood-vessels or lymphatics: different parasitic micro-organisms in these liquids attack and overcome the defending army of phagocytes and leucocytes, live upon the blood, and secrete a toxine or poisonous miasm which may be fatal; these events may arise in the puerperal state, or from accident or operative causation.

In the puerperal, accidental, or operative state the site of attack is some laceration, wound, or injury; as of the perineum, vagina, cervix, uterus, or unclosed venous sinuses or lymphatic vessels of the ovic or placental site, generally by retention within the cavity of the uterus of portions of placenta, perhaps of adherent membranes or of blood-clots. In the absence of the use of antiseptics, micro-organisms may successfully attack the raw tissues, and in this state of endosmosis affect the system. They are particularly infectious in the state of comparative emptiness of the vessels caused by the coincident hæmorrhage; but



when the part is granulating such absorption does not occur, the vessels are in a state of fulness and tension, and the tendency is towards exosmosis in relation to the growing of new tissue.

The attack is through the veins or the lymphatics, perhaps through lymphoid cells, by the open mouths of which canals these micro-organisms may enter. In the former case septic phlebitis results, in which the inflammation is proportionate to the quantity and quality of the sepsis. Thus, if the cause be virulent, the tunica interna becomes suppurative, and the progress of the septic germs, rapidly spreading towards the heart, may be at intervals temporarily checked by the formation of thrombi. These, however, are speedily similarly affected, they disintegrate, become loose in the enlarging lumen of the veins, and form the nidus of fresh infection which permeates the body and especially affects synovial membranes; death is the result. If the sepsis be less virulent, the thrombi may maintain a firmer attachment to the venous inner walls, but are liable to become loose and block the heart, or form the nucleus therein of larger coagulations; or they may form infarctions in the lungs, producing pleuro-pneumonia; or clotting may advance toward the heart by gradual vein-wall infection, so that thrombosis may extend from the uterus along the uterine and ovarian and, on the left side, the renal veins; and perhaps on both sides it may extend into the vena cava, and thence, on the right side, perhaps infect the right renal vein. Or perhaps in only one vein in the broad ligament a septic thrombus, guarded toward the heart by a sufficiently healthy adherent clot, may suppurate, burst through the venous coats, infect the connective tissue, and produce a pelvic cellulitis, discharging in the direction of least resistance.

Should a virulent septic absorption take place, especially through lymphatic vessels, the blood may at once be so affected, probably by secretion of bacterial toxine, that it becomes disorganised, and death results from general acute septicæmia. A less virulence gives time to permit septic inflammation of special structures, as of serous or mucous membranes; or a local suppuration from septic retention in a lymphatic gland in a broad ligament forming suppurative cellulitis; or, in a less septic degree, resulting in inflammatory induration and resolution.

The common cause of puerperal peritonitis is the effusion of septic fluid from the fimbria infected by continuity from the uterine cavity. Thus the slight primary oozing may cause a peritonitis, inducing fibrinous exudation which occludes the fimbria by adhesion. Should the quantity of fimbrial effusion be greater the peritonitis is stronger. If the quality be virulent and the quantity large, the fimbrial effusion being continuous or recurrent, the peritonitic exudation is sero-purulent; such adhesion as occurs is feeble and ineffective for occlusion, and the peritonitis is general and virulent.

Or, less frequently, it may be caused by the rupture, by pressure of the child, of a septic suppurative salpingitis into the abdominal cavity; or such a tube may thus burst into the connective tissue of the broad ligament, producing a virulent pelvic cellulitis.

Tuberculosis in the genital organs may occur either by the arrival of the tubercle bacillus by the intestines, by the blood, or through the vagina. If by the intestines, the bacilli, probably swallowed in tubercular pulmonary sputum, have penetrated the intestinal glands, infected the peritoneum, and thence entered the fimbria and attacked the tube, and perhaps spread to lower parts of the genital canal. Coincidentally the more distant peritoneal surface, and, by deeper attacks, the underlying structures of the ovaries, tubes, uterus, and broad ligaments, may be affected. And a nidus in the genital organs having thus occurred, farther advance into the heart and lungs, perhaps through the bronchial glands through the medium of wandering lymphoid cells, may be effected. Secondly, tubercular pus may escape from the tube through the fimbria, and reinfect the peritoneum.

Or the bacilli, derived from swallowed tubercular pulmonary sputum or tubercular ulcerating intestinal glands, may be detained in the lower rectum in constipated or liquid fæces; and successfully attacking the lymphoid cells, may enter lymph glands, induce suppuration around the anus, and produce rectal fistula. Thence by progressive lymph-gland disease, the connective tissue of the broad ligament may be attacked, and, by suppurative destruction, the peritoneum and adjacent genital organs.

By the blood bacilli, escaping from a softening pulmonary tubercle, may travel in the current until they arrive at a capillary in the genital organs, where they may conquer a lymphoid cell and develop a tubercle, — perhaps in a lymph gland in the broad ligament, producing tubercular pelvic cellulitis.

By the vagina bacilli may gain entrance from an adjacent rectal tubercular fistula, or other tubercular suppuration of which a sinus may perhaps open into the vagina, and the bacilli travel upwards. Or the sperm may contain bacilli, which advance and infect. Or the discharge of a suppurating tubercular gland, perhaps submaxillary, may be conveyed by the finger of the woman within her vaginal orifice. The bacillus, having gained entrance, is attacked by a wandering lymphoid cell, which it may conquer; and thus a second, gaining nutrition from the tissue of these cells, may enter a lymph-gland and produce tubercle, which may suppurate and break down. Should the bacilli be very numerous and powerful, a general infection of adjacent structures and infection of cardiac proximal glands ensues, and the disease has extensive foci. But if the bacilli be but of moderate vigour, a strong fibroid sac wall of condensed connective tissue is formed about the abscess, and permeation of bacilli is effectually resisted. Thus a tubercular abscess in the broad ligament may be coincident with a suppurating submaxillary gland without farther extension; but a foetid bacillus may have infected the pus.

When by uncleanness, or the passage of urinary crystals or sugar, or of small worms from the rectum, a vulvar or vaginal irritation has been caused, micrococci, as staphylococcus and streptococcus, finding suitable nutrition, may enter the vagina and induce an inflammatory

state called vaginitis, causing pruritus of the vulva. This occurs the more readily if the hymen be contracted, so that the secretions are retained; or under the influence of the venous engorgement of pregnancy.

Hydatid tumours, which are of the animal kingdom, may have a situation in the wall of the uterus, ovary, tube, peritoneum, or connective tissue [*vide* article "Hydatids" in *Syst. of Med.*]. The sexual organs are displaced according to the size and direction of growth of the tumour. By rupture or puncture dissemination of the fluid and of daughter cysts is effected; and, if into the peritoneum, fibrinous exudation produces adhesions which may bind down the whole tumour to adjacent structures, or, being highly vascular, may resemble a skein of scarlet floss-silk; or, by continuous escape of necrosed contents, may set up a progressive and virulent peritonitis.

#### VII. Accidental and operative.

Accident, which is here used to mean the unusual effect of a known cause, is the common cause of vaginismus, which is the spasmodic contraction of the muscles about the orifice of the vagina, producing dyspareunia. When the hymen is lacerated in union, its segments retract to the vaginal opening at various sites according to its formation; but most generally towards the posterior commissure. Subsequent frequent union and irritation may prevent the healing growth of epithelium over the raw edges, which, becoming inflamed, develop hyper-vascular and hypersensitive papillæ. Their continued irritation by attempted union, by the friction of walking, or by the constant bathing of their surfaces in the acid vaginal secretion, may maintain the condition. Any attempt to enter the vagina produces a reflex contraction of the muscles which close the opening, as of the bulbo-cavernosus muscle, and of the adductors of the thighs, as well as a retraction of the pelvis from the source of the pain. The same effect results from a similarly produced non-healing tear of the posterior commissure, causing a fissure; from the intense sensitiveness of an angioma or vascular caruncle at the orifice of the urethra; from the repeated sexual act in nervous girls full of sexual disgust; and also from repeated ineffective union of a feeble male with a sexually disposed female inducing a hyperactive and dissatisfied spasmodic muscular state.

By direct force, as a fall or blow, cystic tumours may be ruptured, of which the effects are described under ovarian cystoma, and a myoma may be bruised, causing venous extravasation and peritonitis, and perhaps its necrosis.

Of the operative causes of disease, the introduction of any kind of dirty instrument may convey septic germs, as of the sound tainted with gonorrhœal matter. Or force may effect a minute necrosis, which may induce inflammation, as in the attempt to pass a sound otherwise than in the line of the uterine canal, whence may result endometritis; or it perforate the peritoneum, as in some cases of the production of criminal abortion — peritonitis.

The forcible replacing of an adherent uterus may rupture vascular

adhesions about the uterus or Fallopian tubes, or a follicular cyst, whence peritonitis.

The application of irritants, such as carbolic acid or iodine, to the endometrium, particularly when the cervical canal is narrow and obstructive, readily puffs up the glandular structures sufficiently to close the inner or outer os. When the escape of the secretions is hindered, reflex irritation results, the muscular fibres contract spasmodically and painfully, and endometritis ensues. This is the more apt to occur when there exists an angle of flexion in the uterus, which may be anteflexed or retroflexed; and the two conditions of a narrow canal with anteflexion are usually coincident in the uterus of feeble development. Thus if endometritis have previously existed, it is accentuated, and evolutionary progress, described in section 1, proceeds.

A yet more vigorous action in the same direction may be from the introduction of the tent, whether sponge, laminaria, tupelo, or slippery bark; since necessarily, by their presence, there is a temporary suspension of escape of secretions, which are augmented by the pressure on and irritation of the endometrial glands by the part of the tent within the uterine body. If the condition of the endometrium, for the diagnosis or treatment of which the tent is used, be already inflammatory, the endometritis may be increased. If not, such tents, and particularly when of sponge, rapidly become septic, and the secretions retained in the uterine cavity are thus tainted, and evolutionary disease, through fimbrial effusion, may advance.

In the dilatation some laceration of the interglandular structures results, and the sponge insinuates itself into the gland-ducts themselves, so that such raw surfaces are the more liable to be septicly infected; and particles of this septic sponge may be retained after withdrawal of the mass. A temperature of  $105^{\circ}$  may thus be rapidly produced.

An intra-uterine stem, which is usually more permanent, is similarly injurious by creating or increasing endometritis by pressure and obstructing drainage.

Injections of fluid may be introduced into the uterus unintentionally by chance pressure of the vaginal tube through a lacerated or dilated cervix, and obstructing the canal, may pass through the tube into the peritoneal cavity, and induce peritonitis; or intra-uterine injections, made with a fine tube, may be retained within the uterine cavity by angularity or stenosis, or hyperplastic approximation of the walls of the canal, and induce colic and endometritis; or perchloride of mercury may be absorbed, and produce acute nephritis and anuria, resulting in uræmic death, due provision for its return not having been made; or the cervical canal may be thickened by the irritation and become stenosed.

Probably few operative measures more frequently cause or exaggerate disease than pessaries. They are always septic by accumulation of secretion about them, and thus present to any abraded spot, which themselves may have created, the bacteria of inflammatory action. By continuous pressure on the vagina they are liable to produce necrosis, and retaining bands may be formed across their bars; or they may embed themselves



in the rectum or bladder. By constant expansion permanent dilatation of the vaginal muscular fibres and the destruction of the vaginal column may be effected; while, if there be vaginal subinvolution, this is continued and usually accentuated. By the separation which they cause the faces of the lacerated cervix are everted; and if the upper limb insinuate itself between them a deep furrow is created, and about it the hyperplasia, by irritation of the interglandular structure, is increased. The body of the retroflexed uterus often falls back on the upper limb of the pessary and becomes very tender, showing that peritonitis has been induced, probably from effusion from the fimbria of a compressed or bent tube; and if a larger instrument be employed the preceding disadvantages are the more apparent.

When evolutionary disease has already created salpingitis, peritonitis, and perhaps follicular disease of the ovaries, there are usually adhesions; and the pressure of the pessary on these affected parts tends to irritate them, and increase the rapidity of progress or recurrence of their diseases. Moreover, the pressure on an ovary congests it, or may effect rupture of a follicular cyst with resulting peritonitis.

A metrotomy by scissors, which divides the circular muscular fibres so that the faces are everted, produces the effects of that degree of laceration without subinvolution; and induces or accentuates endometritis. If the operation be performed with a two-bladed metrotome, an unequal or excessive division may divide a vessel into the broad ligament, whence may result an extensive hæmatocele, which may become septic; the passage of the knife through the lateral vaginal fornix may have similar results; or, in an irregular division, the blood may escape into the peritoneum.

If the os be closed by operation, as by excessive suturing in trachelorrhaphy, or cicatrization with contraction after a small metrotomy, the secretions — such as blood and mucus after coincident curettage, and the catamenia — are retained in the uterus and tubes, may distend them, and escaping through the fimbria into the abdominal cavity, produce peritonitis. This may or may not be virulent, according to the quality of the sepsis or degeneration and quantity of the fluid thus effused. If secretions be retained in the cavity of the uterus with stenosis of the os by such intermittent causation, they are likely to become septic, and endometritis results, and perhaps further disease.

In puncture with a trocar, for exploration or treatment, if the instrument be septic, putrefactive germs may be introduced, and necrosis and septicæmia result; this may happen in a myoma pierced by an exploratory trocar or electric needle.

The introduction of an exploratory trocar into a solid abdominal tumour is liable to be followed by peritoneal hæmatocele, which, if aseptic and in moderate quantity, may be absorbed, and in part contract; but if too large for nutrition, it may undergo necrosis and become purulent; it will certainly do this if septic by escape of necrosed tissue from the puncture in the tumour.

If the tumour contain fluid, some of it, and perhaps much, may ooze through the small opening after the withdrawal of the canula. If such escape be into the peritoneum, the peritonitis is proportionate to the degree of virulence and the quantity of the fluid, as well as of the septic influence of the operation, an influence perhaps due to admission of air through the canula: similarly, pelvic cellulitis may thus be erysipelatous and pyæmic.

The withdrawal of the liquor amnii from a tubal extra-uterine foetation is liable to be followed by escape of blood; and, on removal of the canula, some may pass into the abdominal cavity. The vitality of the ovum may thus be destroyed, and its necrosis occur with tainting of the escaped clot, whereby a progressive and finally virulent peritonitis is produced.

In the operative puncture of a dermoid cyst, the canula, blocked by the fat and hair, may, in its removal, discharge some of the sac contents into the peritoneum, inducing peritonitis; and the inflammation, extending through the opening made, may affect the lining wall of the sac, and produce pus formation, or septic suppurative germs may be thus introduced directly.

Perforation of the intestine, so that the gases and fæces escape into the peritoneum, is intensely and virulently inflammatory from the presence of the bile, bacteria, and matters decomposed or ready for decomposition. In leaking puncture of the bladder, healthy effused urine is in itself non-irritating; but if unhealthy or decomposing, or in excessive quantity, very irritating.

In the treatment of abortion, undue haste may induce attempt at removal of the ovum before separation of the chorionic villi or placenta has taken place, so that part remains in a necrosing state in the uterus; or curettage may be practised thereon, or deeply on the prominent placental site, from want of knowledge that such projection is normal.

Any operation in which the peritoneum is opened, and septic germs or disorganising fluids, gases, or solids are admitted, may lead to peritonitis of a degree proportionate to the quality and quantity of such irritating agent.

W. BALLS-HEADLEY.

#### REFERENCES

1. BALDY. *Text-book of Gynæcology*.—2. BALFOUR, F. M. "On the Origin and History of the Uro-genital Organs of Vertebrata," *Journal of Anatomy and Physiology*, vol. x. 1876; "On the Structure and Development of the Vertebrate Ovary," *Quarterly Jour. of Microscop. Sci.* vol. xviii. 1878.—3. BANTOCK. "On the Pathology of certain so-called Unilocular Ovarian Cysts," *Trans. Obstet. Soc.* vol. xv.—4. BARNES. *The Diseases of Women*.—5. BEDDARD, F. E. "Observations on the Ovarian Ovum of Lepidosiren," *Proceed. of the Zool. Soc. of London*, May 4, 1886.—6. BELL, F. J. *Comparative Anatomy and Phys.*—7. CALDERWOOD. "On the Ova of Teleosteans," *Jour. of the Marine Biol. Assoc. of the United King.*, new series, vol. ii. No. 4.—8. COATS, J. *Manual of Pathology*.—9. CUNNINGHAM. *Journal of the Marine Biol. Assoc. of the United Kingdom*, new series, vol. ii. No. 1; vol. iii. No. 2.—10. CULLINGWORTH. *On Pelvic Cellulitis*.—11. DARWIN. *The Descent of Man; The Origin of Species*.—12.

DORAN, ALBAN. "On Myoma and Fibro-Myoma of the Uterus and Allied Tumours of the Ovaries," *Trans. Obstet. Soc.* vol. xxix.; *Tumours of the Ovary*.—13. EMMET. *Principles and Practice of Gynæcology*.—14. GARRIGUES, H. J. *Diseases of Women*.—15. GEDDES, P. *Encyclopædia Brit.* vol. xx. p. 408; vol. xv. p. 368.—16. GEDDES and THOMPSON. *Comparative Anatomy*.—17. GEGENBAUR. *Elements of Comparative Anatomy*.—18. GREY'S *Anatomy*.—19. HABERSHON. *Diseases of the Abdomen*.—20. HAMILTON, D. J. *Textbook of Pathology*.—21. HART, D. BERRY. *Female Pelvic Anatomy*.—22. KIRKES. *Handbook of Physiology*.—23. MINOT. *Human Embryology*.—24. NAPIER, LEITH. "Habitual Abortion," *Obst. Trans.* vol. xxxii. 1890.—25. PLAYFAIR, W. S. *The Science and Practice of Midwifery*, "On Removal of the Uterine Appendages in Cases of Functional Neurosis," *Obst. Trans.* vol. xxxiii. 1891.—26. POZZI. *Medical and Surgical Gynæcology*.—27. RUFFER, A. *Quar. Jour. of the Microscop. Soc.* vol. xxx. Part 4, Feb. 1890.—28. SAVAGE. *On the Female Pelvic Organs*.—29. SCHACHT. "On Ruptured Tubal Gestation," *Brit. Gynæcol. Jour.* Nov. 1893.—30. SCHULTZE. *Trans. by MACAN. Displacements of the Uterus*.—31. SHATTOCK, S. G. *The Morton Lecture on Cancer*, May 19, 1894.—32. SNOW, H. *The Proclivity of Women to Cancerous Diseases; On Cancers and the Cancerous Process*.—33. SUTTON, BLAND J. *Surgical Diseases of the Ovaries and Fallopian Tubes; Evolution and Disease*.—34. TAIT, LAWSON. *Diseases of Women and Abdominal Surgery; Diseases of the Ovaries; Lectures on Ectopic Pregnancy*.—35. THOMAS and MUNDE. *Diseases of Women*.—36. THORNTON, KNOWSLEY. "Three Hundred Additional Cases of Ovariectomy," *Med. Chir. Trans.* vol. xx.; "Cases Illustrating the Surgery of the Kidney," *Lancet*, 1895.—37. WELLS, SIR SPENCER. *Diseases of the Ovaries; Ovarian and Uterine Tumours*.—38. WIEDERSHEIM. *Grundriss der Vergleichenden Anatomie der Wirbelthiere*, 1893.—39. WILLIAMS, J. W. "Tuberculosis of the Female Generative Organs," *Johns Hopkins Hospital Reports in Pathology*, ii. Baltimore, 1892.—40. WINKEL, by CHADWICK. *On Childbed*.—41. WOODHEAD, G. S. "Practical Pathology: An Address on the Channels of Infection in Tuberculosis," *Lancet*, Oct. 27, 1894.

W. B.-H.

## DIAGNOSIS IN GYNÆCOLOGY

THE differential diagnosis of particular diseases will be found under their respective headings in the several articles of this volume. The object of this article is to collate, with a view to diagnosis, the various symptoms and physical signs met with in the diseases peculiar to women. The subject naturally resolves itself into two parts—the history of the patient and the physical examination; and it will be treated under these headings.

**THE HISTORY OF THE PATIENT.**—For purposes of reference a note should be made of the date, and of the name and address of the patient. The investigation may be conveniently carried out in the following order:—

*Age.*—The age of the patient; which has a direct bearing on many matters—such as menstruation and child-bearing. Before the age of ten menstruation is naturally absent; and again after the age of fifty: though even in healthy persons the dates of onset and cessation vary within wide limits. Impregnation occurs only during the period of active menstrual life. The age of the patient is often of importance also in deciding upon the nature of disease. For instance, cancer rarely occurs before thirty or forty years of age, and more often about the

time of the menopause. Nevertheless, we must not forget that cases occasionally occur at an earlier age; I have seen the disease in an advanced stage at the age of twenty-nine, and even so early as twenty-five.

*Social Condition.*—Information as to marriage or spinsterhood, or, again, whether the patient be widowed or separated from her husband, has often an important bearing in determining the question of pregnancy, and in affording presumptive evidence of sexual intercourse. And the further information as to the length of time the patient has been married, widowed, or separated, as the case may be, is often a necessary factor in deciding these important questions. Many diseases occur only in connection with gestation; others only as the outcome of delivery; others again follow sexual intercourse. A note of these matters, therefore, often provides a valuable step towards diagnosis.

*Occupation.*—The occupation of the patient has often a material bearing upon the disease from which she suffers. For instance, cooks, charwomen, and laundresses, being constantly on their feet and exposed to a hot and often steamy atmosphere which tends to relax the tissues, are specially disposed to various forms of prolapse. In the case of married women, it is well to ascertain the occupation of the husband; for many deductions may be drawn from this knowledge. The occupation of the husband not only affords some notion of the means of the patient, but often leads up to some conclusion concerning the nature of the illness. Take, for instance, the case of a patient suffering from vaginal discharge, one in which it is difficult and yet important to determine whether the discharge be merely an ordinary leucorrhœa or a gonorrhœa: now there are certain classes of the community on the male side — and therefore on the female side also, when they happen to be married — who are particularly prone to gonorrhœa, such as soldiers, sailors, and policemen. In these cases additional information, sufficient to warrant a diagnosis, can usually be obtained.

*Leading Symptoms of which Complaint is made.*—Having made a note of the foregoing preliminary particulars, it is well before making further inquiries to ascertain generally from the patient the precise symptom or symptoms of which she complains. Patients often give a very indirect answer to the question, "What is it you complain of?" — such a reply as "the insides" or "the womb"; and they are apt to give as their answer (often with considerable modification) what any doctor who has been previously consulted may have told them. It is then necessary to inquire what brought her to seek advice. In the vast majority of cases it will be found that actual pain or discomfort in some part or other is the leading symptom from which the patient seeks relief. But in some cases pain may be entirely absent, or only present under certain conditions, as, for instance, during coitus; or sexual intercourse may be effected with difficulty or even be impossible. Others will, perhaps, speak of a swelling in the abdomen as the leading feature in the case. Some, again, will apply for advice because there is no family; they feel well in every respect,



but, having been married for, perhaps, some two or three years, and no family resulting, they come for advice on that matter. In many of these cases there is no particular illness or discomfort, but it will be found that in the vast majority of them some morbid condition is present. The points with reference to which the patient makes complaint, and the approximate length of time during which she has experienced each symptom, should be noted. These inquiries will probably afford some clue to the nature of the case, will indicate the line any special investigation should take, and will serve as a foundation on which to construct the diagnosis. The object of the present article, however, is not to take up the leading individual symptoms of which the patient complains, and then, by following the clues thus obtained, gradually to elaborate a diagnosis; but rather to provide a general systematic form of investigation which will be found serviceable in the vast majority of gynæcological cases. After these preliminary inquiries the symptoms and discomforts of which the patient complains can be sifted and amplified. This method of inquiry provides a very valuable, but often neglected quantity of negative evidence. For it often happens that the patient comes complaining of something which may be but a trivial deviation from health; yet, if her case be gone into systematically and carefully, according to the method I propose, important information will be forthcoming which will enable us to find or suspect, even before we go into physical examination, that she has some other and concomitant disease, either quite independent of the matter of which she makes complaint, or entirely subservient to it.

Having ascertained, then, the main points to which the patient wishes to draw attention, and for the relief of which she seeks advice, it is well to proceed to ascertain the menstrual and obstetric history of the case.

**The Menstrual History.** — At the outset let me emphasise a point to which too little attention is given, namely, that in order to obtain first from the patient a menstrual history of so complete a character as to answer the purposes of investigation, it is necessary to ascertain the normal character of the menstruation in the individual. For there are among women wide individual differences in respect of this function. In order to judge whether any change has taken place in the menstruation of any woman after its first commencement, the natural character of her own menstruation must be determined in the first instance. A certain feature of the function which in one woman might be considered an abnormal variation may be the usual and natural condition in another. And therefore, I repeat, that in each individual case it is necessary to ascertain the individual character of the function in order to appreciate the importance of any change in it.

The points in the history of menstruation to which attention should be directed are as follows:—

*The Age of Commencement.* — Menstruation begins earlier in some women, later in others; it usually begins between the thirteenth and fourteenth year. In hot climates it begins at an earlier age; and it

varies also in different races. It begins sometimes as early as the eighth or ninth year; sometimes it does not begin till the eighteenth, nineteenth, or twentieth. And these variations occur, be it noted, altogether apart from disease—such as anæmia.

*The Rhythm of the Flow.*—It often happens that after the first period or two the patient sees nothing again for some months, perhaps for a year or more. After the lapse of some time the flow recommences and continues regularly. We are frequently consulted in such cases. A girl—say of twelve or thirteen, or a little older—has menstruated once, but the flow has not been succeeded by others in the ordinary way; she is consequently brought by her mother to the physician with a view to treatment. These cases, as a rule, require no treatment if the patient be generally in a healthy condition, and has not exceeded the age at which menstruation usually begins. It should be recognised that in some individuals it is natural for one flow to show itself, or perhaps for two or more to appear, and then for the courses to remain in abeyance for some months, often for a year or longer, before the rhythmical flow is established.

Change of residence, especially from the country to London, is often attended with cessation of the flow during the stay; it returns, however, subsequently, and in the meantime the general health is unaffected.

With most women the flow comes on at intervals of twenty-eight or thirty days. In some women, however, it appears at shorter intervals—from two to three, or more frequently still, from three to four weeks. In others the intervals are prolonged, and the menses recur after an interval of five to six weeks, and sometimes longer; yet these patients, so far as one can judge, are in perfect health, and the menstrual function is otherwise performed in a proper and natural manner. It will be found on inquiry that such peculiarities are natural to the individuals.

In other patients, again, the menses do not occur regularly, and this in patients who have gone on for years without any illness or disturbance to account for the irregularity. Such persons are never quite regular, but if they complain of no illness, irregularity must be looked upon as the regular thing for them, and is not necessarily to be regarded as pathological.

*The Duration of the Flow.*—Here again considerable variation is found within physiological limits. In the majority of women the period lasts four or five days; in others it lasts a shorter time,—very often only one day, and even in some cases but a few hours. In others the flow continues four, five, six, seven, or eight days, or even a little more without the presence of any abnormal condition or any interference, so far as one can learn, with the general health. In some women it by no means infrequently happens that the flow comes on for a day or two, then stops for a day or two, and again comes on for two or three days. This again, being the natural condition of some individuals, is not by any means necessarily pathological. In others it will be found that without being pathological the period lasts a variable time; some-

times it may last a day or two, at other times rather longer; occasionally it is extended over a week. The duration of the flow in such cases depends in great measure on what the patient is doing at the time—the more active the patient's life the more extended the periods.

*The Daily Amount.*—As a rule, the longer the flow the greater the amount of daily loss. But in this, too, there is room for considerable variation without exceeding physiological limits. It is difficult to estimate the amount of the daily loss; but a rough guide may generally be obtained from the patient by ascertaining the number of diapers which she uses during a period, or during each day of the flow. Some patients assert that they never have been able to wear a diaper, as it stops the flow. Fortunately such persons do not lose very much. Of course, in using this guide to the loss, due allowance must be made for individual habits of cleanliness; for while some will only let the diapers become partially soiled, others will be less nice. Still the number of diapers serves fairly as a rough estimate of the daily loss. If a patient tell you that diapers are “no good at all,” and that she has to put on two or three at a time, or uses big cloths or towels, you may be quite sure she is losing very freely. Such information is exceedingly valuable and suggestive. Some patients will even go further, and say that they have to lie up during the period, and put something under them to protect the bed-clothes, the loss being so copious. The usual average is, perhaps, three or four a day—say, one to two during the day, and one at night; or sometimes three during the day, and one at night. When the patient is up and about, the more active she is the more she loses, and, generally speaking, the loss is less at night. When the amount of the daily loss is great, it is very likely that clots will be passed at the same time; generally speaking, the more copious the discharge the greater the liability to the passage of clots. As a rule the menstrual fluid does not clot unless it be very free in amount. These clots may be quite small; or they may be of considerable size, as big as the thumb, or even larger; in this case they are due to an accumulation of blood in the vagina and its subsequent coagulation. The passage of clots is more usual in women who have borne children. With the flow there may also be shreds, which are often looked upon as clots by the patient; but they can be distinguished by the fact that shreds float out in water. Such a condition is associated with severe pain, and is pathological.

Pain, again, varies in different persons, though short of that which is of so severe a character as to come under the head of dysmenorrhœa. In some patients at the time of menstruation there is absolutely no pain and practically no discomfort: these persons, however, are rather the exception than the rule. With women generally, as the flow approaches, there is a sense of fulness, congestion, disturbance, and weight in the pelvic organs. They become more highly sensitive at that time, and in a very considerable number of cases pain is present in greater or less degree; the pain may be at the bottom of the back, in the lower part of the abdo-

men, or may be referred to one or both ovarian regions. When it is severe it may extend beyond these points to the hips, or down the thighs as far as the knee; in other cases it may extend up the abdomen, even to the level of the breasts. The amount of the pain may be roughly estimated by ascertaining whether the patient has been in the habit of taking any remedies for its relief — such as peppermint, ginger, or alcohol in various forms, especially in the form of gin; or, in some cases where medical advice has been sought, as laudanum and even hypodermic injections of morphia, besides various other remedies. The amount of the pain may be gauged also by the patient's answer to the question whether she has been able to be up and about her work, whatever it be, at the time of the period; or whether she has had to take to her bed for a longer or shorter time, and have hot local applications—such, for example, as a hot brick wrapped up in flannel (a useful means of removing pain in some cases), hot sand-bags, hot fomentations, stupes, or poultices.

The time at which the pain begins varies in different individuals. In some the pain will begin a day or two before the flow, in others a few hours before, while in others it comes on with the flow. It varies also in duration: generally speaking, it begins two or three hours before the flow and stops after the first day; in other cases it is continued to the end of the second or third day, and may last even to the end of the period. As a general rule, however, the pain is at its worst during the first few hours of the flow, and begins to diminish as soon as the flow has come on freely.

*The Attendant Symptoms.*—In some patients, as I have said, there is no pain and no discomfort; in others, severe frontal, occipital, or general headache, sick-headache, or vomiting may be present. In other cases some disturbance of the bowels, either constipation or diarrhœa, takes place at the time of the menses. Most patients, especially during the earlier part of the period, require to pass water more frequently than at other times; and with this excessive frequency there is occasionally a little pain in micturition. Occasionally patients complain that they have fits—hysterical fits—during the flow: these are generally weakly patients who are below par, and, being subject to hysteria at other times, their tendency to it is increased at the periods. Epileptic attacks also seem to be more readily induced during the menstrual flow than at other times.

*Leucorrhœa* is a symptom rather of the intermenstrual period. In a healthy woman there is no discharge, or very little, after the cessation of the menses; but some women have naturally a little discharge of a whitish character for a day or two after the flow. In other patients it occurs a day or two before the flow; in others, again, it goes on to a greater or less extent during the whole intermenstrual interval. This discharge is of an opaque, whitish character. In patients who are reduced in health there is a liability to a certain amount of leucorrhœal discharge apart from any local pelvic trouble. Discharge of a thick glairy mucus in large quantity is, however, pathological; or if the dis-



charge become yellowish or purulent it passes the physiological bounds. Occasionally a peculiar odour may be noticed with a menstrual flow which does not pass the physiological limit; but foetid discharges are invariably pathological.

*Abnormal Variations.*—The date at which the deviation from the usual course took place must be ascertained. This deviation may take one or more forms. The menses may have come on too frequently, at shorter intervals than previously; they may have come on quite irregularly; the duration may have increased or diminished, or the daily loss may have increased or diminished. Pain again, previously absent, may have become a prominent feature. In any case we should ascertain precisely what the change has been, and the time at which it set in. Moreover, we should endeavour to ascertain from the patient herself what she considers to have been the cause of this change in menstruation. It will frequently be found to date from the onset, or from a confinement or subsequent miscarriage, or it may have begun with some definite illness.

The menopause usually sets in between the forty-fifth and the fiftieth year. Occasionally it occurs earlier, or, on the other hand, it may be delayed till after the fiftieth year. Forty-eight is, perhaps, the average year of its occurrence. At this time also, as at the beginning of the catamenial periods, the menses are often irregular. Menstruation, regular up to a certain time, may suddenly cease, and the patient see nothing more. Occasionally the courses stop for a month or two, perhaps longer, then the patient has a period or two at irregular intervals, and after this they cease entirely. In other cases the periods gradually get less and less for a year or two and then cease; in others, again, the menopause is ushered in by considerable floodings. It is often difficult to distinguish these changes associated with the menopause from the symptoms of distinct and serious disease. It must always be borne in mind, especially in the case of flooding, that women are particularly liable to malignant disease at this time. An examination, therefore, becomes advisable in order to determine whether the conditions are physiological or due to some disease of the organs.

Both for purposes of future reference and as a guide to the advisability of examination by means of the sound, inquiry should be made as to the date of the onset of the last period, and the time at which the last period ceased.

It must be remembered with reference to this point, that patients frequently think they have menstruated when actual hæmorrhage has occurred during the course of gestation. Patients will frequently come complaining of various troubles, and stating that the last period only ceased, let us say, a week ago; but careful inquiry will elicit the fact that for two or three months prior to that time they had seen nothing at all, and still closer investigation will show that this so-called last "period" had not the character of natural menstruation. Whereas, perhaps, the patient has never been in the habit of passing clots before, these appeared in the discharge on the occasion referred to: or, although

the periods had generally lasted a week, on this occasion the flow had continued for two or three days only, and the amount lost was different.

**The Obstetric History.** — I have already dealt with the importance of ascertaining the social position of the patient. It is still more important to know what has been her obstetric history — the history of her labours and miscarriages, if any; because a very considerable amount of illness which presents itself to the gynæcological physician is the result of impregnation and of disease following upon delivery or abortion.

The first points to ascertain in this connection are the number of the children, and the date of the last delivery; next, whether there have been any miscarriages, and if so, when they last occurred. Indeed, it is a good plan to go not only as far as this, but to ascertain also with regard to the children at what period of pregnancy they were born, for they may have been premature; and as to the miscarriages, at what period of gestation they took place: the answers are to be entered in their order. All this can readily be recorded in very short compass if we put down the labours and miscarriages in the order of their occurrence, and indicate at the same time the period of gestation at which each of these events took place by means of figures representing months and fractions of months.

Where premature labour has occurred or miscarriage taken place, it is well also to ascertain from the patient whether any particular cause could be assigned for the occurrence. A labour may be brought on prematurely, or a miscarriage may be induced in various ways, as by a fall, a fright, a blow, a strain, over-work, long railway journeys, mental exhaustion, and so forth; and it is well to fortify one's self with this information. Therefore we inquire in each case of premature labour what cause the patient can assign for the occurrence. Of course, in many cases it will be found that no cause, or an obviously inadequate cause, is assigned; and it is in these cases especially that the immediate cause may be found in or about the uterus — such, for instance, as the presence of a fibroid in the uterus, or chronic metritis and endometritis.

Apart from the question of prematurity, the character of each labour should be ascertained; whether a long and difficult, or an easy one; and if long or difficult, whether it was aided by instruments. Patients will generally volunteer the information if "the child came the wrong way"; or if, as they say, it was a "cross-birth." The "cross-birth" of patients, however, is by no means invariably what the physician understands by that name, for a breech presentation is also usually dubbed with the name of cross-birth. In order, therefore, to make sure that the case was in reality one of cross-birth, it is necessary to inquire further whether turning was performed. A breech would probably be delivered as such, and no version would be performed; but if the patient states that she was chloroformed, and that the doctor put in his hand and turned the child, you conclude that the case was really a cross-birth, and not a breech presentation.

Again, apart from the difficulty of the labours, it is well to ascertain

whether they have been accompanied by flooding or not; and whether there has been any tear of the soft parts so considerable as to have necessitated the introduction of sutures.

*Illness during Pregnancy and after Delivery.*—Ascertain also from the patient whether her health continued good during pregnancy. Excessive sickness, convulsions, œdema, and flooding should be particularly inquired after. Patients are generally ready to inform us as to any such illnesses as these. With regard to illness after delivery, however, unless questioned rather closely, patients are liable to mislead the doctor. It is well to ask the patient, in the first place, whether she got on well after the child was born; and if in any doubt as to her answer, ask also how long she kept to bed. Patients as a rule do not keep their beds more than a fortnight after delivery; if that period has been exceeded the chances are that some definite illness occurred during the puerperium. It does not necessarily follow, however, that because the patient was able to get up after the lapse of ten or fourteen days that she had no illness; for such illness may have been of a transitory kind, or she may have got up for a few days while still ill, and had to return to bed again for some weeks.

Illness after delivery is usually of a febrile character. If the patient be asked whether she had any fever, she will often reply that she had a slight touch of "milk fever." We shall always look with suspicion upon such an answer, which probably indicates not mere mastitis, or a local trouble giving rise to a certain amount of general febrile symptoms, but more often than not it indicates some illness of a septic nature. Such a condition, in order to prevent alarm on the part of the patient and her friends, and sometimes—too often I fear—to shield the reputation of the doctor, is put down as milk fever. Mastitis and septic mischief have this in common, that both usually begin about the second or third day; if, however, the illness be due to mastitis the breasts as a rule become very hard and tender with the influx of milk at that time, and the disturbance usually subsides within two or three days when the flow is well established. On the other hand, in cases where the breasts have not shown symptoms of local disorder (despite the fact that the patient calls the condition "milk fever"), but in which tenderness and pain in the abdomen (which you can generally infer from the use of hot flannels, hot fomentations, poultices, or turpentine stupes) have been prominent symptoms, it may generally be concluded that not "milk fever," but septic mischief of local origin was present. It will be found necessary to cross-question patients rather carefully in order to ascertain these facts. If the patient had fever, but is unable to give information as to the height of the thermometer, she will often be able to afford an indication of the severity of the fever by stating whether a rigor or severe shiver occurred at the outset of the illness. It may be taken for granted that a rigor at the outset generally means fever running up quickly to rather a high point. In long-continued febrile conditions repeated rigors generally occur later in the disease; and these rigors are generally associated with copious perspirations.

Again, with reference to the general condition of the patient suffering from febrile disease, useful additional information may often be obtained by inquiring whether she was able to take her food properly while lying-up; or whether she had to be kept on slops, and so forth. Finally, if a patient tell you that she can say very little about her condition, as she was unconscious for the greater part of the time, you may rest assured she was delirious as well as febrile.

The conditions, apart from febrile illness, which keep a patient in bed longer than the usual time, are either general weakness, from some pre-existing disease or from hæmorrhage before or during labour or immediately afterwards, or laceration of the perineum, or some inter-current disease, such as pleurisy, rheumatic fever, scarlet fever, or measles.

**Previous Illnesses.** — It is advisable in the next place to ascertain from the patient what previous illnesses she may have had, and whether associated with the pelvic organs or not. Many of the troubles complained of will be found to date from illness occurring at or soon after delivery or miscarriage. But it may frequently be found, of course, that some particular symptom takes its origin from disease not directly associated with the pelvis: for example, any wasting disease, or illness of long standing, such as typhoid fever or phthisis, often exerts an important influence on the menstrual function. Thus at the beginning of a febrile illness there may be severe loss of blood, especially in acute diseases — such as typhus fever and small-pox — which are often associated with hæmorrhage. Again, when a patient has been laid up for a considerable time by prolonged illness — such as typhoid or rheumatic fever, the periods are frequently held in abeyance for a long interval, and remain so until she regains her strength.

**The History of the Present Illness.** — We should ascertain first of all the date at which the present illness began: this date will form a landmark from which to make more particular inquiries. We should ascertain also the cause which the patient assigns for her illness, as this will often give a clue of considerable value to the nature of her ailment.

Of the particular symptoms to which attention should be drawn I put pain first, because it is one of the most common. Under this head are included dysmenorrhœa, that is, pain at and associated with the menses; and dyspareunia, or pain and difficulty in sexual intercourse. Pain in association with the functions of the bowel and bladder will be dealt with under the head of diseases of these organs.

Next, inquiries should be directed to ascertain if, in other respects, the menstrual function has been naturally performed. Under this head are menorrhagia, metrorrhagia, or hæmorrhage during the natural intervals of the periods; amenorrhœa, or absence of the periods when they ought naturally to have been present; and, finally, leucorrhœa, a white or yellowish discharge occurring between the periods.

Attention should then be paid to the question of local swelling or tumour, whether in the privates or in the abdomen; then to any inter-



ference with the due discharge of the functions of the bladder and bowel; and, finally, to such general symptoms as anæmia, wasting, fever, and so forth. It will be necessary for us to consider these matters in greater detail, and to enumerate the morbid conditions among which these symptoms are likely to be found.

*Pain.*—The site of the pain must be noted, whether it be continuous or spasmodic; and its character, whether it be sharp and cutting, or dull and aching; also whether it be associated with tenderness; whether it be relieved by any one of various applications, such as heat, cold, pressure, or the adoption of a particular posture, and in what way it is apt to become aggravated.

The causes of pain in the pelvic organs are very various. Inflammatory and congested conditions stand prominently forward. Under this head are included a very considerable number of the diseases to which women are specially liable: such are pelvic peritonitis or perimetritis; parametritis, or disease of the cellular tissue of the pelvis; hæmatocele—hæmorrhage into the pelvic peritoneum setting up pelvic peritonitis; hæmatoma—hæmorrhage into the pelvic cellular tissue, which sets up parametritis and perimetritis in its neighbourhood; the outcomes of inflammatory mischief, such as pelvic abscess; inflammatory disease of the appendages (tubes and ovaries), such as hydrosalpinx, hæmatosalpinx, and pyosalpinx; and inflammation of the uterus itself—metritis. Among the congestive conditions I may mention prolapsed or precident uterus, and prolapse of the tubes and ovaries. Adhesions, or rather the stretching of adhesions left from previous inflammatory mischief due to ovarian or tubal disease, are a frequent cause of pain and discomfort; and so, finally, are various tumours in the pelvis, some of which originate in the uterus, some in the tubes and ovaries, and often cause pressure and pain, especially if they have become impacted.

In the acts of micturition and defæcation it is frequently found that pain present in the pelvis becomes aggravated, especially if it be the result of inflammatory conditions and adhesions. In other cases pain occurs only on micturition and defæcation; these will be considered later in association with bladder and intestinal troubles.

*Dyspareunia* may occur from various causes. It is frequently associated with vaginismus. This condition may be primary or secondary; that is to say, it may have existed from the beginning of attempts at coitus, or it may have come on afterwards as the outcome of some other difficulty in the act. It may arise from inflamed conditions of the vagina, from whatever cause; from excessive indulgence in coitus, or from gonorrhœal inflammation. It is also often found in connection with congenital defects and fissures about the vulva, with inflammation of the hymen, or with ulcers, specific or otherwise, about the vulva; or it may frequently be associated with gonorrhœal warts, or from warts resulting from a long-standing discharge, not necessarily of a gonorrhœal nature, but due to irritation—such as occurs, for instance, in masturbators. And, lastly, dyspareunia and vaginismus may be found in association with urethral caruncle.

Apart from these causes directly connected with the orifice of the vagina, dyspareunia sometimes occurs in association with some trouble in the immediate neighbourhood, such as a rectal fissure or piles. Difficulty and pain in coitus are present in some cases of prolapsed uterus; in these cases, if the uterus be outside, sexual intercourse is rendered practically impossible, but pain is not necessarily present. With retroverted and retroflexed uterus dyspareunia is apt to be present; and in cases where the ovary is prolapsed and congested the pain is often severe. In inflammatory conditions of the pelvis, whether of the pelvic peritoneum (perimetritis) or of the cellular tissue (parametritis), and in cases of hæmatocele and hæmatoma, which become secondarily associated with inflammatory disease, pain in sexual intercourse may result; or again, from adhesions between the tubes, ovaries, uterus, intestine, and other parts of the pelvis, which result from long-standing inflammatory mischief. Cysts in the vaginal wall, though rarely of considerable size, occasionally give rise to the difficulty. Polypi of the uterus passing down into the vagina, and fibroid growths becoming impacted in the pelvis, will give rise to difficulty and very often to pain in coitus.

*Dysmenorrhœa.*—Pain at the periods may have been present from the very beginning of menstruation, or have resulted subsequently. The division into primary and secondary is useful. The secondary variety is very often of an inflammatory character, and dates either from a confinement or a miscarriage. In inquiries with reference to dysmenorrhœa we should first ascertain where the pain is situated, whether in the abdomen or in the back; and if in the abdomen, whether it is confined to one side or the other, or extends from side to side; whether it radiates down the thighs, or extends for a considerable distance over the abdomen. The pain sometimes extends as high as the mammary region. Next, we should ascertain when the pain begins, whether before the flow or with the flow; and if before the flow, how long before. Usually it will be found that it commences a few hours or a day or two previous to the onset of the period; and in cases of severe dysmenorrhœa the pain may come on even so long as a week before the period. The duration of the pain is variable. In some cases the pain which has begun before the period will cease when the flow begins or is freely established. It may cease after the first day, but sometimes in severe dysmenorrhœa is continued for two or three days, and occasionally to the end of the period; or again it may even continue after the flow has stopped.

With the view of ascertaining, in the next place, the amount of the pain, we should inquire whether the patient has to lie up or not while it lasts; whether she is incapacitated from following her usual occupation. Some patients who keep about will tell us that they would lie up if their circumstances permitted. Others will tell us that they are always obliged to take to bed during the first day or two of the periods; others, again, will say that to do so would be of no use, the pain being so severe they cannot keep quiet and have to roll about on the floor. Such facts

as these will enable us to judge whether the pain be severe or not. In cases of less severity, it is possible to judge of the amount of the pain by the patient's answer to the question whether any particular treatment has been found efficacious in its relief, such as — to take the most popular — hot gin and water, hot ginger, local applications, fomentations, hot bricks wrapped up in flannel, or hot-water bottles; and, finally, whether they have been under medical treatment during the periods.

The causes of dysmenorrhœa are to be found either in some general condition of ill health, or in some morbid condition of the pelvic organs. Let us consider, first, those general conditions which occur apart from the uterus and pelvic organs. A very common example of general ill health, accompanied by severe menstrual pain, takes the form of a general neurosis, the patient suffering from what is termed spasmodic dysmenorrhœa. This form of the disease is always primary in character, beginning, as a rule, with the first period, and continuing with increasing intensity as time goes on. In cases of anæmia and chlorosis, and in cases of chronic constipation, dysmenorrhœa of some severity may be present without recognisable disease of the uterus or pelvic organs. In cases of congestion of the pelvic organs, by whatever cause produced — secondary, it may be, to heart or liver disease — and in cases of inflammation in the pelvis, dysmenorrhœa may be a prominent symptom. But the pain in these cases occurs not, as a rule, during, but between the periods. The loss which occurs relieves the congestion, and to some extent diminishes the inflammatory condition by depletion, so that as soon as the flow is freely established the pain from which the patient had previously suffered sometimes ceases, and returns when the period has come to an end.

Certain diseases of the uterus itself are likewise apt to be associated with the occurrence of pain at the periods. And first may be mentioned the incompletely developed uterus, the uterus being smaller than it should be; very often no bigger than the top of the little finger. With it incomplete development of the ovaries is likely to be associated; indeed, these organs may be absent altogether.

A small congenitally anteфлекed uterus is another form of incomplete development frequently associated with dysmenorrhœa. A still more common condition takes the form of an elongation of the cervix in its vaginal portion, an abnormality known as conical cervix, and usually associated with a small orifice or "pin-hole os."

Fibroma of the uterus is not painful, as a rule, except at the periods. During the active congestion which accompanies the early part of the periods fibroids often give rise to considerable dysmenorrhœa.

In cases of displacement of the uterus dysmenorrhœa may become a prominent symptom, especially when the uterus becomes retroverted and retroflexed, and impacted at the floor of the pelvis between the sacro-uterine ligaments. There the congestion in the fundus becomes very marked, and severe pain in the early part of the period results.

Membranous dysmenorrhœa, though rare, is almost invariably asso-

ciated with severe pain, during which the patient passes a membrane either as a cast of the uterus or in shreds.

*Menorrhagia and Metrorrhagia.* — Menorrhagia is an increase in the flow at the periods, and takes the form of increased duration of the flow, shortening of the interval between the periods, or increased daily loss. Metrorrhagia is an irregular flow between the periods. These maladies often merge one into the other, so that it may become impossible to draw any distinct line between them. Of the estimate of quantity I have already spoken.

The colour of the flow varies in different cases. When the flow is very profuse it has a bright hue. In other cases it is dark in colour, the usual colour of the menstrual discharge; in others, again, it takes on a brownish appearance, especially as a free flow is beginning to clear off. There may sometimes be a mere show; or, on the other hand, the loss may take the character of a pinkish serous discharge. Occasionally, if there be any leucorrhœal discharge as well, streaks of blood will be found in association with it.

*General Causes of Hæmorrhage.* — In a certain number of cases of anæmia and chlorosis, in contradistinction to the usual condition of amenorrhœa, menorrhagia appears. This is the case rather in the severer forms of the disease; indeed, the loss tends to aggravate the disorder. In congestive conditions of the heart and liver menorrhagia is apt to be present, and, of course, metrorrhagia too; for owing to the obstruction of the circulation an excessive flow is apt to occur not only at the periods, but also between them. This loss may be compared with the escape from a safety-valve, and should not be injudiciously checked. In some cases of acute specific disease, and especially in those associated with hæmorrhagic tendency — such as typhus fever, scarlet fever, small-pox, and, to a less extent, measles — menorrhagia is apt to set in at the beginning of the fever. Sometimes it becomes marked and requires particular treatment. In some blood diseases, again, such as purpura and hæmophilia, an increased flow at the periods is apt to occur.

*Local Causes of Hæmorrhage.* — From these general causes I pass next to certain conditions in the pelvis outside the uterus. In inflammatory conditions in the pelvis — such as parametritis and perimetritis — menorrhagia and metrorrhagia sometimes occur. These cases almost come into the same category as those in which the heart and liver are diseased; for in many of them, at any rate, the vessels become involved, the veins become plugged, and so the return of the blood to the heart is interfered with. The loss in such cases, therefore, unless it be excessive, has a beneficial tendency by depleting, and thus relieving the inflammatory condition.

In pelvic hæmatocele and pelvic hæmatoma bleeding is apt to take place. The usual history in such cases is that, either as the result of some excessive work undertaken at the period, or of a chill caught after the flow has begun, the discharge suddenly ceased, but reappeared and thereafter continued for a longer time than it should do, perhaps for a fortnight.



In some cases of ovarian congestion and ovaritis menorrhagia and metrorrhagia are liable to ensue. Especially is this likely to occur as the result of too frequent sexual intercourse soon after marriage. In ovarian disease proper — such as ovarian cystoma — amenorrhœa is the rule; but in a certain number of cases menorrhagia and metrorrhagia take its place. The same remark also applies to cases of tubal disease, — hydrosalpinx, hæmatosalpinx, and pyosalpinx; in these, though amenorrhœa more frequently occurs, menorrhagia and sometimes metrorrhagia are occasionally present.

The abnormal conditions of the uterus itself, which give rise to hæmorrhage, may be conveniently divided into those found in the unimpregnated and those occurring in connection with child-bearing, whether during pregnancy or during the puerperium.

In cases of metritis, with disease of the lining membrane of the uterus — a state to which various names, such as fungous and villous endometritis, have been given — hæmorrhage is an almost constant symptom: there is excessive flow at the periods, and very often a loss also between the periods; the periods come on too frequently, last too long, and the daily loss is more than natural.

In cases of mucous polypi of the cervix, again, hæmorrhage is by no means uncommon; and with this I ought to mention a condition antecedent to it, namely, the thickening of the mucous membrane of the cervix, with proliferation of the gland tissue, which often extends to the vaginal portion, and produces what is known as an adenomatous erosion. This condition gives rise not only to excessive hæmorrhage during the periods, but also very frequently to hæmorrhage during the intermenstrual time. It may be particularly noted that in this case the hæmorrhage — a metrorrhagia — is apt to follow sexual intercourse.

Fibroids or myomas in the uterus are frequently, but not invariably associated with hæmorrhage. Fibroids projecting on the peritoneal surface — that is to say, subperitoneal fibroids — do not in themselves cause hæmorrhage; fibroids in the wall of the uterus, unless they encroach on the cavity and cause it to enlarge, do not give rise to hæmorrhage; but hæmorrhage may be caused by fibroids projecting into the uterine cavity, that is to say, by submucous fibroids; although here again bleeding is not an invariable concomitant. Fibroids, however, when they become polypoid, almost invariably produce hæmorrhage. It must be remembered that fibroids are frequently multiple; and that the symptoms may be due, not to a subperitoneal fibroid even of considerable size, but to a smaller mass not always easily recognised beneath the mucous membrane. The hæmorrhage which occurs in association with fibroids is generally menorrhagic in character, although it occasionally occurs in the intervals between the courses, and is often very profuse. It is probably due directly to an unhealthy condition of the uterine mucosa induced by the presence of the fibroid mass.

Malignant disease of the uterus, which generally affects the cervix, is a potent cause of hæmorrhage. Especially is it one of the causes of

hæmorrhage occurring at the climacteric. The hæmorrhage may be menorrhagic, but it is more frequently metrorrhagic in character. From the cervix the malignant disease may spread to the body of the uterus. Primary cancer of the body of the uterus is also associated with hæmorrhage, but it is a comparatively rare condition, and the hæmorrhage when it occurs is not, as a rule, very severe. It usually takes the character of a watery discharge with a pinkish tinge rather than of a severe flow of blood; though in certain cases even of primary cancer of the body severe floodings may take place. In sarcoma of the body of the uterus hæmorrhage is apt to occur and to constitute a prominent symptom.

Senile endometritis is another condition occasionally met with, giving rise to hæmorrhage after the menopause. The distinction between senile endometritis and cancer of the body of the uterus can, as a rule, only be determined by exploration of the cavity of the organ.

Special Causes of Hæmorrhage during Pregnancy and after Delivery. — It may be noted that occasionally the catamenia persist after impregnation has taken place; the periods being sometimes continued during the first, second, and third months, rarely later than that. It is often difficult in any individual case to say whether a discharge of this kind is really a menstrual period; but usually, if it preserve the same character as a period and come on regularly, it may be looked upon as such. When, however, from some morbid condition, bleeding occurs during gestation, the loss is specially apt to take place just as the monthly cycles come round; consequently an impression of regular periods may be produced in the patient's mind.

Hæmorrhage in association with gestation may be symptomatic of threatened abortion, of bloody, fleshy, or vesicular mole, or of ectopic gestation; and, during the last two months of pregnancy, of accidental hæmorrhage or of placenta prævia. It will suffice merely to mention these matters here.

It may be useful to bear in mind that the other causes of hæmorrhage occurring during pregnancy — hæmorrhage, that is, from the uterus — are generally associated either with cancer of the cervix; or with adenoma of the cervix, commonly called erosion; or sometimes with mucous polypi.

Hæmorrhages occurring shortly after delivery do not fall within the scope of this volume. Hæmorrhage setting in after the patient has left her bed and the lochia have ceased may depend on one of several conditions. It frequently occurs in cases of subinvolution; often in association with inflammatory disease, or with the retention of some portion either of placenta, membrane, or blood-clot within the uterus; or with the presence of a fibroid growth, either in the wall or beneath the submucous tissue of the uterus, or of a polypus. Moreover, the mucous membrane may take on an irregular, villous, or fungous character, associated in many cases with very considerable hæmorrhage.

More or less sharp hæmorrhage will occur in some cases when the patient begins to get up; and on examination it will be found that the

uterus is prolapsed, retroverted, and larger than it should be from congestion, and sometimes firmly impacted in the pelvis. In cases of inversion of the uterus a considerable loss often takes place, with leucorrhœal discharge in the intervals.

Slight hæmorrhage after delivery may occur from incompletely healed laceration of the cervix, or from erosion. Cancerous growths of the cervix must also be borne in mind as a possible cause of hæmorrhage.

*Amenorrhœa.* — During pregnancy, as well as during suckling, amenorrhœa is the rule. But, as already stated, the courses sometimes persist during the early months of pregnancy, and even later. Many women, too, especially those of rather florid temperament, will continue to have the periods regularly during suckling, and that even from a month after delivery. It is necessary to bear this feature in mind, because patients are apt to be misled in consequence, and even when far advanced in pregnancy will persist that no impregnation can have taken place. A general impression also prevails that suckling prevents impregnation. To a certain extent this is true, but by no means invariably. Women who have been suckling regularly may be found far advanced in pregnancy, having one child at the breast while carrying another.

When the menopause is artificially induced, as by the removal of the ovaries, for fibroid disease of the uterus or other such reason, amenorrhœa as a rule results. Occasionally the patient will have one period afterwards, sometimes two or three. In cases, however, where the periods continue regularly it is doubtful whether the whole of both ovaries has been removed; removal of one ovary does not stop the flow. In some cases after complete removal of both ovaries an irregular loss occurs, resulting from concomitant disease of the uterus itself, such as the presence of a small polypus, mucous or otherwise, in the cervix or body: or disease of the lining membrane of the uterus.

Among the general causes of amenorrhœa anæmia stands first in point of frequency.

Amenorrhœa is also apt to result from any cause of malnutrition, particularly acute illness or chronic wasting disease: it may be found, for example, after rheumatic fever, during and after typhoid, in phthisis and Bright's disease, and so forth.

A chill taken during menstruation will sometimes stop the periods without producing any discoverable lesion of the pelvic organs, but often inflammation and other disorder is at the same time induced.

In cases of chronic inflammation of the ovaries and tubes, in ovarian cystoma, in hydrosalpinx, hæmatosalpinx, and pyosalpinx, amenorrhœa is sometimes though not invariably present. In some cases the regularity of the periods may not be interfered with, and in others menorrhagia takes place.

In rudimentary conditions of the ovaries and uterus primary amenorrhœa is frequently present, and, if not absolute, it will usually happen that the periods occur at considerable intervals — five or six weeks, perhaps two or three months intervening — and the loss is very slight, a

mere show on each occasion. But here again amenorrhœa is by no means invariable. I have known cases of small uterus and ill-developed ovaries with menorrhagia.

*Leucorrhœa.*—In making inquiries with regard to leucorrhœa we should ascertain, first of all, the character of the discharge. It may be white or colourless, opaque or glairy; that is, either like milk or like the white of egg. The natural discharge from the cervix is glairy and mucoid, becoming opaque when it passes into the vagina. On the other hand, in disease the discharge may be of a yellowish or creamy colour; or it may be greenish, or brown and mixed with blood. With a view to ascertain the extent of the discharge the patient may be asked whether it is such as to require a diaper. The answer will generally afford some means of ascertaining its amount. Then we should inquire when it occurs—whether it persists during the whole intermenstrual period, or comes on just before or just after the flow—and when it is of greatest intensity. As a rule leucorrhœal discharges are most marked just before or just after the menstrual flow.

The causes of leucorrhœa are general weakness, anæmia, wasting diseases, and worms. Thread-worms in children are especially apt to be associated with considerable leucorrhœal discharge. Under these circumstances the mother frequently brings the child to the doctor, imagining, perhaps, that she has been tampered with. We should look out for worms in such cases, or for the vulvitis which in children follows such diseases as measles, scarlatina, whooping-cough, chicken-pox, and the like.

Leucorrhœa may be the result of vaginitis, arising either from the presence of foreign bodies in the vagina, from some irritation of the vagina, as in cases of masturbation, or from the presence of ill-fitting pessaries or pessaries that have been worn for a considerable time. With vascular caruncle of the urethra there may sometimes be a little leucorrhœal discharge.

Gonorrhœa is a potent cause of leucorrhœal discharge, often in its worst form; but even in these cases the discharge is not necessarily profuse.

Soft chancres about the vulva, again, are frequently associated with a certain amount of leucorrhœal discharge. Tears about the vulva, too, such as occur after operations or after delivery, if they fail to heal properly, may give rise to a leucorrhœal discharge.

Erosions of the cervix, whether merely catarrhal or adenomatous, are generally accompanied by a discharge which, as it pours away from the cervix, is glairy; but it becomes opaque on reaching the vagina unless the quantity be great. The discharge in some of these cases is very profuse.

Eversion of the cervix, generally the result of a bilateral laceration of the cervix occurring during delivery, is attended by leucorrhœa.

Leucorrhœa is also to be found in cases of mucous polypi of the cervix, in cases of cervical catarrh, in cases of subinvolution of the uterus occurring after delivery or miscarriage, in cases of senile corporeal endometritis, in disease of the uterine mucosa, whether associated



with submucous fibroids and polypi of the uterus or not, in cases of cancer of the uterus, in cases of chronic inversion of the uterus, and, finally, in some cases of pyosalpinx and pelvic abscess, or suppurating cyst in the pelvis, when the discharge finds its way by perforation through the uterus or, more frequently, through the vagina. In all such cases the leucorrhœal discharge is liable to alternate with unusual losses of blood.

Fœtor of the discharges (which necessarily means sapræmic decomposition) may be met with in cases of threatened miscarriage and of incomplete abortion; in cases of subinvolution associated with retained products of gestation; in cases of severe inflammatory mischief, such as occurs in gonorrhœa, and particularly when an abscess has opened into the canal; in cases of cancer; in cases of senile endometritis; and in some cases of submucous fibroids and polypi in which the tumour has sloughed. The discharge, however, may take on an offensive odour under other conditions,—as, for example, with mere rents about the vulva, such as occur after delivery,—and in some cases of cervical erosion and eversion.

*Local Swellings or Tumours.*—We should ascertain from the patient if she has noticed any swelling either in the abdomen or privates; when the swelling first appeared, and whether it be persistent or variable in character. We should inquire also the site where it was first noticed, and the direction in which it has grown. In order to ascertain from the patient whether any considerable enlargement of the abdomen has really taken place, it is well to ask whether she has had to let out her clothes. Uterine enlargements commence at or near the middle line; ovarian tumours are usually noticed first at one side or the other, and only after a time, as increase takes place, do they extend upwards and towards the middle line. Distensions of the tubes and inflammatory effusions are usually found near the groins, and thence extend into the iliac fossæ.

Among unilateral swellings about the vulva may be mentioned abscess, cyst, varicose enlargement, inflammatory induration of the labium, and possibly hernia. Protrusions in the middle line are commonly urethral caruncle, cystocele, rectocele, or prolapsed and proident uterus.

The various tumours met with in the abdomen and pelvis will be enumerated later in dealing with the abdominal and vaginal examination of the patient.

*Urinary Symptoms.*—We should note the character of the pain, if present, and the time at which it occurs—whether during micturition, previous to micturition, or following micturition. We should note also the frequency of micturition, and whether it takes place most frequently at night so as to disturb the patient's rest, or during the day when she is up and about; or if, on the other hand, there be difficulty in getting the water to pass, or such inability as to necessitate the use of the catheter. Or, again, the water may constantly run away; or be passed involuntarily on coughing or straining.

The character of the urine may be partly learned from the patient, and will probably also be tested. Pus, blood, or mucus from the vagina may be found mixed with it, and, in order to obtain a sample uncontaminated, it may be advisable to pass the catheter. Many general diseases — such as diabetes, insipidus, and mellitus; hysteria; nocturnal incontinence — may give rise to one or other of the foregoing symptoms; or affections of the urinary organs not a part of the special diseases of women — nephritis, for instance, whether acute or chronic; calculus either in the kidney, ureter, or bladder; pyelitis; cystitis; or displaced kidney — may interfere with the urinary function.

Associated with disturbance of micturition may be mentioned cystocele with or without prolapse of the uterus; until the swelling be pressed up this frequently causes difficulty and delay in passing water. In cases of vesico-urinary and vagino-urinary fistulas, constant or nearly constant dribbling away of the urine takes place. Vascular caruncle frequently gives rise to pain in passing the water. In vulvitis, such as sometimes affects weakly children; in vaginitis, from whatever cause — such as foreign bodies, ill-fitting pessaries, and so forth, or resulting from general weakness; and in cases of gonorrhœa, the urethra is often implicated; and pain in passing water is complained of as well as difficulty in getting the water to pass: occasionally there is retention.

In cases of polypi from the uterus coming down into the vagina, and of various tumours (especially when impacted in the pelvis), such as fibroids, ovarian tumours, parovarian tumours, dermoid tumours of the ovary, tubal distensions, hydrosalpinx, hæmatosalpinx, and pyosalpinx, ectopic gestations, and retroverted gravid uterus, micturition may be interfered with; and incontinence, excessive frequency of micturition, pain in passing water, or retention may take place. The same may occur in advanced cases of cancer, of sarcoma of the uterus, and of inflammatory conditions in the pelvis, such as perimetritis, and parametritis, hæmatocele, hæmatoma, and pelvic abscess. Finally, unusual frequency of micturition may be reckoned as one of the earliest signs of pregnancy.

*Intestinal Symptoms.* — We should ascertain the frequency with which the bowels are relieved, and if defæcation be painful, difficult, or associated with tenesmus. If constipation be a prominent feature the effects of remedies often afford us some information. The presence of blood, mucus, or pus in the stools should be noted. We should next note the condition of the tongue, and inquire as to the appetite and digestion — whether nausea or vomiting be present, and if so, the time at which they occur, and the character of the vomit; facts which may have an important bearing on the question of gestation.

It may be remarked that these intestinal troubles, like the urinary, are not by any means necessarily associated with disease in the pelvis; but more often result from general disease, such as chronic constipation; or from disease of the lower bowel, such as hæmorrhoids, stricture, malignant disease, and fistula in ano. But among other causes may be instanced recto-vaginal fistula, rectocele with prolapse of the posterior vaginal wall,

prolapse of the uterus and procident uterus, tumours impacted in the pelvis, cancer, sarcoma, and fibroids of the uterus. Again in inflammatory swellings, such as perimetritis and parametritis, hæmatoma, hæmatocele, and pelvic abscess, the inflammatory process often involves the mucous membrane of the bowel, and sometimes leads to the passage of blood and mucus. Pain and difficulty in defæcation are apt to be present when the ovaries and tubes are prolapsed, and the uterus retroflexed or retroverted; for, if the bowels become constipated, the attempts at defæcation force the fæces down above the misplaced mass, which may act as a sort of ball-valve on the rectum, and increase the difficulty.

*General Symptoms.*—Anæmia, wasting, fever, and so forth, will generally come to light with the other and more special symptoms of which the patient has already complained.

*Previous Treatment.*—Finally, we must ascertain and note what previous treatment, if any, has been adopted, how long it has been carried out, and with what result. We should note particularly whether the patient had been confined to bed, and for what length of time; and what local measures, if any, have been adopted, either in the form of applications, such as douches, tampons, pessaries, or of operative procedures.

**THE PHYSICAL EXAMINATION OF THE PATIENT.**—In conducting the physical examination of the patient attention will first be directed to the abdomen; afterwards to the internal examination.

**Examination of the Abdomen.**—We should note first the size and shape of the abdomen. If it be enlarged measurements must be taken. These are from the umbilicus to the xiphi-sternal articulation; from the umbilicus to the top of the symphysis; from the umbilicus to the anterior superior spines, right and left; the girth at the umbilicus, and in great enlargements the greatest girth.

In the next place the umbilicus is to be observed, whether it be protruded or depressed: it protrudes when there is free fluid in the abdomen and in cases of umbilical hernia; it is unusually depressed when there is much fat on the abdominal wall.

A note also should be made of the condition of the linea alba, the marked pigmentation of which, at any rate in the lower part, is often an indication of pregnancy.

The existence of striæ or skin cracks on the external surface of the abdomen is to be noted; their number, their size, their colour, their position, and the direction in which they run. Skin cracks are an indication that the abdomen is or has been distended; not necessarily by pregnancy, though that is the most common cause: ascites and other like distensions will produce them. The colour of these cracks will vary with the lapse of time since the distension occurred; fresh skin cracks are usually pinkish in colour; old ones are whitish, or, if they have become redistended, acquire a bluish tinge. Their number and size will vary not only according to the amount of the distension, but also in individual cases. Some women pass through full term pregnancies, and have

not a single stria left to tell the story; in others the abdomen may be scored by striæ before the mid-term of pregnancy is reached.

The thickness of the abdominal walls varies in the main with the amount of their adipose tissue. In women who have not had children they are often extremely rigid, especially in neurotic subjects; whereas in women in whom the abdomen has been distended, or who are generally lax of tissue, the walls may be so exceedingly thin and loose that the hand may sink deeply enough on the abdomen between the separated recti for the promontory of the sacrum to be felt; and, perhaps, the brim of the pelvis may be mapped out through the anterior abdominal wall. Any hernial protrusion on the abdominal wall, whether at the umbilicus or in the groin, should be duly noted; and likewise any considerable tenderness or resistance in the abdominal walls. Neurotic patients under manipulation are very apt to contract the walls of the abdomen; but in these patients the resistance is general over the abdomen, and not limited to the lower part or to one side, as is usual in pelvic disease.

*Abdominal Enlargements.*—The main causes of enlargement, apart from distinct tumours in the abdomen, are the following:—

i. General obesity, a thick adipose condition of the abdominal wall, associated with a large deposit of fat in the omentum and other parts of the abdomen beneath the peritoneum. This deposit of fat often occurs about the menopause. The abdominal wall may be increased to some four or five inches in thickness, a state of matters which very much interferes with any examination of the deeper structures of the abdomen.

ii. Flatulence often produces general enlargement of the abdomen, and likewise interferes with examination. It is associated with a tympanitic note on percussion. In some women enormous distension is thus produced. In young girls, also, considerable distension of a more localised nature often gives rise to the impression of pregnancy; but here, again, the tympanitic note on percussion is distinctive enough: under chloroform such swellings disappear.

iii. General enlargement of the abdomen, due to fluid accumulation, is accompanied by dulness on percussion, as in ascites associated with disease of the heart or liver. The effusion may be serous, fibrinous, purulent, or hæmorrhagic.

iv. Occasionally a distinct tumour of the abdominal wall itself may be met with. I have seen a lipoma which, in its position at any rate, very closely simulated a small ovarian tumour—for which, indeed, it had been mistaken; but careful examination showed that it was situated in the abdominal wall and not beneath it.

*Intra-abdominal Tumours.*—If a tumour be found in the abdomen it is important to learn when the swelling was first noticed, and whether attention was drawn to it by pain or by the increase of the abdomen. We must also ascertain at what point it was first observed, whether in the upper or lower part of the abdomen, or to one side or the other; the direction of its subsequent growth; its rate of progress, and whether its growth has been steady or variable in rate.



The tumour may appear to be rising out of the pelvis in the middle line, or to one side of it; to spring from the lumbar region, or from the upper part of the abdomen under the ribs. The longest and shortest measurement of the tumour must be noted; its shape and outline, whether regular or irregular, or ill-defined; its consistence, whether it be hard, as is usual in fibroids, or soft, as are most ovarian swellings; whether fluctuation be present or not, and if present, whether the fluid thrill is conducted equally in all directions. The mobility of the tumour should be determined, and also the point where it appears to be attached. Occasionally a tumour may be fairly movable, but limited by adhesions in one or more directions — conditions which can readily be estimated by palpation through a thin and lax abdominal wall. In endeavouring to ascertain the mobility of the tumour one may notice a distinct crepitant feeling transmitted to the hand, which usually indicates that some inflammatory mischief has produced a considerable roughness of the tumour. In some cases, again, under favourable conditions of the abdominal wall, a pedicle may be felt. The extent of the area of dulness on superficial or deep percussion may or may not correspond with the size of the tumour. The stethoscope will enable us to ascertain whether there be any sounds about the tumour. Apart from the sounds of pregnancy, in some cases of fibroid tumour a sound resembling the uterine bruit of gestation may be heard; or if the surface of the tumour has been roughened by inflammation, friction sounds may be distinguished: in many cases adventitious sounds are conducted from the aorta or intestine.

Pressure on the main venous trunks gives rise, in some cases, to engorgement of the veins running over the abdominal wall; in others to varicose veins about the vulva, thighs, and legs, and to œdema of the lower extremities.

In exceptional cases, as a means of diagnosis, an exploratory puncture of the tumour may be allowed, and a microscopical examination of the fluid made in order to ascertain the nature of the swelling; finally, exploratory opening of the abdomen may sometimes be called for to clear up an obscure case.

In dealing with tumours in the abdomen, it is at the outset advisable to eliminate the possibility of pregnancy. Before proceeding, therefore, to a differential diagnosis of the intra-abdominal tumours it will be advantageous to briefly consider the indications of gestation.

*Diagnosis of Pregnancy.* — The shape of the uterus is to be noted, whether there be any marked obliquity or not; this, if present, is usually directed to the right side of the abdomen. On palpation the tumour may present the characters of a gestation, that is to say, of fluid containing a solid (the fœtus); with easy conditions of the abdominal wall as regards thickness and resistance, it may be possible to map out the position of the back, of the small parts, and of the head of the fœtus; and to feel the fœtal movements. In some cases a thrill may be felt, though this is by no means common. Contractions of the uterine

muscle can usually be induced, and are an important diagnostic sign, but they occur also in fibroid tumours. At the sixth month of pregnancy the fundus of the uterus reaches to about the level of the navel; at the fifth month it is about half-way between the navel and the pubes; at the fourth month it can be distinctly felt above the pubes; before that period it is not easily felt above the brim. At the seventh month the fundus arrives about half-way between the navel and the ensiform cartilage; at the eighth month it rises to the level of the xiphi-sternal articulation, and during the last month, as the foetal head comes down in the pelvis, it sinks a little again in the abdomen. But it must be remembered that the size may be interfered with by various circumstances. In cases of multiple pregnancy — twins or triplets — the uterus at any given stage is larger than in a normal gestation: this is also the case when the liquor amnii is excessive, and in hydatidiform mole. The womb is smaller than usual when the foetus is abnormally small; when the foetus dies, prematurely or not, or is interfered with in its development. When the contents of the uterus have been converted into a mole the organ may remain for a long time almost stationary in size. If, on auscultating the abdomen, the foetal heart is heard with certainty, the question of gestation is at once settled. But inability to hear the heart sounds does not necessarily contra-indicate pregnancy, for this sign is naturally absent till four and a half months of development have been attained: and, even later, it cannot always be heard even though the foetus be alive. By observing the rhythm of the foetal heart, and at the same time counting the rate of the maternal pulse, the possible error of mistaking conducted sounds from the mother's arteries may be avoided. While listening to the foetal heart, it is often possible, with the hand on the other side of the abdomen, to feel the foetal movements quite distinctly; and also, perhaps, contractions of the uterine muscle, induced by the pressure of the stethoscope: both of these signs are valuable indications of pregnancy. In some cases, though not often, one may light upon an umbilical bruit, a sound produced by the pressure of the stethoscope on the umbilical cord; it is synchronous with the foetal pulse, not with the maternal. Much more frequently the uterine bruit is heard, a sound which is said to be produced in the large sinuses of the uterus; this bruit is synchronous with the maternal pulse. The uterine bruit varies much in different cases, and in its characters; it may vary even in the same case at different times. Sometimes it is a soft murmur; sometimes its note is almost hard and shrill; it varies from time to time in intensity and pitch, and in the position in which it is heard. It may be taken as diagnostic of the uterine character of the tumour, but not necessarily of pregnancy; for it is sometimes heard in cases of uterine fibroid.

If the uterus is regularly enlarged, if no indication of disease be present, and if the uterus corresponds in size with what might be expected, the diagnosis of gestation is usually warranted, even in the early months before the advent of any certain indication. But when compli-

cations are present; or the history is misleading, as in ectopic gestation; or unreliable, as when the patient has reason to conceal the event, it is well to withhold an opinion until some certain sign appears. In doubtful cases some evidence may also be derived from the breasts. The breasts usually become distended and enlarged before the mid-period of pregnancy is reached; the nipples and the areolæ surrounding them become more prominent; the follicles which they contain stand up from the surface; and the pigmentation, especially in dark-complexioned subjects, becomes augmented, and spreads beyond the true areolæ so as to form a darkened area, with small spots upon it devoid of pigment: this is exceedingly characteristic of pregnancy, though not absolutely diagnostic of it, for similar pigmentation is occasionally observed in cases of fibroid tumours of the uterus and of ovarian cystoma.

Further, fluid may exude from the nipple on pressing the breasts. Though the pigmentation and secretion afford presumptive evidence of pregnancy, it must be borne in mind that these signs are of little or no value after the first pregnancy, for they persist after delivery.

The striæ of distension on the breasts rarely occur except as the result of engorgement during lactation.

It is rare for an abscess to form in the breasts except after child-birth or miscarriage, so that the mark left by an abscess is also fairly presumptive evidence of past gestation.

Before passing on to speak of the various tumours found in the abdomen it will be advisable to anticipate somewhat, by referring also to the internal examination in cases of pregnancy. If the patient be pregnant, the following points may be noted in making the internal examination:—

The cervical canal is often patulous during the fifth, sixth, and seventh, and even during the eighth month of gestation; but it closes as the time of delivery approaches, and before the dilatation proper to labour begins. Its size, its dilatability, and its length should be noted. The cervix becomes thickened and softened during gestation, and during the last three months of pregnancy it apparently becomes drawn up out of the vagina.

If the cervix is sufficiently dilated, it may be possible to feel the membranes within it, or possibly the placenta in cases of placenta prævia, or blood-clot if hæmorrhage have occurred. Blood-clot may be distinguished from placenta or membrane by its vanishing under pressure of the finger and thumb; membrane or placental tissue will not entirely give way, or if doubt still remain the mass may be removed for examination.

Through the cervix it may be possible to distinguish the presenting part of a foetus; but more frequently its presence may be ascertained by pressure through the anterior vaginal wall in front of the cervix. During the mid-period of gestation ballotement can be practised, and, if obtained, it forms a valuable additional indication of pregnancy.

*Abdominal tumours, other than pregnancy,* may be met with in the abdomen. Tumours of the abdomen beginning above and coming

down from under the ribs, though they may be met with among gynæcological patients, do not properly fall within that category, except as a matter of coincidence. Of such, for instance, are enlargements of the liver and gall-bladder, of the spleen, and of the stomach. Other tumours of the abdomen take their origin very variously; as, for instance, cancer of the bowel, fæcal accumulations, localised peritonitis with effusion, adhesions the result of peritonitis (which I mention here because the impression of a very distinct tumour is often conveyed by such adhesions), omental cysts, hydatids, and tumours of retroperitoneal origin. Tumours of the kidney beginning in one or other lumbar region frequently find their way to the brim of the pelvis; or, at any rate, into the iliac fossa. An abnormally mobile or wandering kidney is frequently observed among gynæcological patients, for the simple reason that this condition, which is more common on the right than on the left side, is usually associated with a general laxity of the patient's parts, and with displacement of the uterus or of the ovaries.

Tumours beginning below may be uterine, tubal, ovarian, or parametric in origin. A full bladder should invariably be reduced, in any doubtful case of abdominal tumour, by passing a catheter. It is not sufficient to rest satisfied with the patient's statement that urine has been passed recently; because, when the bladder is full, though micturition be frequent, the amount passed is small, and often consists merely of overflow.

Of the various uterine enlargements some preserve the natural contour of the uterus, others are irregular in shape. Among the regular enlargements may be reckoned gestation; hydatidiform, blood, and fleshy mole; an abnormal enlargement of the uterus remaining after delivery, under the general term of subinvolution; metritis; pyometra, and hæmatometra. Among the irregular enlargements may be instanced fibroid tumours of the uterus—subperitoneal, interstitial, submucous, or polypoid; and malignant disease, cancer, and sarcoma.

Enlargements of the tubes, so great as to cause abdominal swelling, may be due to tubal gestation, which often ruptures and spreads into the broad ligament, or into the abdominal cavity; hydrosalpinx; pyosalpinx, whether gonorrhœal or septic; hæmatosalpinx, which is often associated with tubal gestation, or produced by some interference with the due flow of blood during a menstrual period.

Enlargements of the ovary may be cystic or solid. Ovarian cystoma is the most common form of ovarian tumour. It is frequently multilocular, and may have undergone change; especially from congestion due to impaction of the tumour, or twisting of the pedicle; and inflammatory mischief may alter the character of the fluid to blood or pus. Dermoid tumours of the ovary frequently occur in young subjects, and are associated with the formation of dermoid structures, such as bone, teeth, hair, skin; these, if left untreated, frequently suppurate and discharge through the bladder, vagina, or elsewhere. Fibroma of the ovary and malignant disease of the ovary, giving rise to solid tumours, are rare



conditions. Papilloma, a semi-malignant disease of the ovary, is apt to find its way through the surface and give rise to deposits associated with the presence of a considerable amount of free fluid, often blood, in the abdominal cavity.

Parovarian cysts are nearly always unilocular and contain clear fluid; otherwise they have much the physical characters of ovarian cystoma.

Local effusions of serum, pus, or blood into the cellular tissue of the pelvis sometimes spread beyond the pelvic region into the abdomen beneath the peritoneum; and find their way to the abdominal wall, into the groin, behind to the region of the kidney, or to the buttocks and vulva. Similar localised effusions into the pouch of Douglas frequently extend upwards into the abdomen, but are there usually limited by matting together of the intestines.

Among abdominal tumours may be included pelvic adhesions, which, by the matting together of the intestines, frequently give rise to the impression of a very distinct swelling over which a certain amount of resonance can usually be obtained.

**Examination by the Vagina.**—In making the vaginal examination it is advisable to deal first with the external parts.

Any signs of irritation on the *skin*, such as redness, inflammation, or excoriations, will be noted. In some cases, in consequence of irritation, an eruption, usually of an eczematous character, appears. The conditions under which this is found are usually such as to give rise to an irritating discharge, as in cancer of the cervix or body of the uterus, in sloughing fibroids, and in some other conditions which have already been mentioned, such as erosions; and in cases of gonorrhœa and severe vaginitis, not necessarily of a local specific character. Signs of irritation may also be present in cases of masturbation; or again, when the uterus is procident, and the vaginal walls, thrust outside, are irritated by friction. In certain cases also of urethral caruncle irritation is set up; and, finally, in diabetes the irritation by the decomposing sugar produces considerable irritation, and even an intractable form of eczema.

The labia majora and minora may be hypertrophied. In patients subjected to the above-mentioned sources of irritation more or less hypertrophy often occurs.

The *clitoris*, too, is a structure which varies considerably in size, and is, in some cases, hypertrophied.

The *orifice of the urethra* may show signs of irritation, more especially where that irritation is associated with pain in passing water.

In examining the *vulva*, its size, the colour of the surface, the presence of varicose veins or of ulcers on the surface, of abscesses or cysts in the deeper structures, should be noted; and also whether there be a discharge bathing its surface, or signs of chronic irritation about the parts, as is frequently evidenced by the presence of small warts. Expansion of the vulva results from child-bearing, especially where the woman has had many children, and in its more marked forms from prolapse of the vaginal walls and falling of the womb; it is especially

prone to occur when not only the parts in the pelvis, but the tissues generally are wanting in tone. On the other hand, the vaginal entrance may be smaller than usual from congenital causes; or from spasm, as in vaginismus.

The colour of the mucous membrane will indicate congestion, either active or passive, or inflammation. In congestion it takes on a sort of peach bloom hue, or varies from that to purple, as in the case of pregnancy, and of some tumours in the pelvis, particularly fibroid tumours; this change may occur also in cases of heart and liver disease. In inflammatory conditions the redness is often associated with much swelling of the tissues. Varicose veins are specially apt to appear during pregnancy, from the pressure of tumours in the pelvis or abdomen, or from some general condition associated with deficient return of blood to the heart, such as takes place in disease of the heart or liver.

Various forms of ulcer may be met with about the vulva. Simple ulcers often occur as the result of delivery, as in the case of a tear failing to heal; or as the result of distension of the parts in the course of examination, especially where a speculum has been used. Syphilitic ulcers are commonly found about the orifice. As the result of acute syphilitic diseases in children, severe ulceration, and even sloughing and gangrene of the parts, is apt to occur.

An abscess about the vulva raises suspicions of gonorrhœa. Abscess of Bartholini's gland, indeed, is often the result of gonorrhœal infection spreading up the duct of the gland and involving the gland itself: abscesses, however, about the vulva are not necessarily gonorrhœal.

The form of cyst usually found at the vulva is produced by a blocking of the duct of Bartholini's gland and retention of the fluid. When the cyst has persisted for some time the walls become considerably thickened, and the only satisfactory way of dealing with it is to dissect it out.

The discharge about the vulva may be of a simple or specific character, and is apt to occur in association with fibroids and polypi, cancerous disease of the uterus (cervix or body), erosion of the cervix, in diseases of the lining membrane of cervix, body, and Fallopian tubes, as well as in cases of general weakness and gonorrhœa.

Cancer, beginning primarily at the vulva, though by no means unknown, is exceedingly rare.

The posterior part of the vulva and the perineum should next be examined, and a note made whether the fourchette has been torn.

The *hymen* in the virgin is various in form. Usually it is a crescentic fold of greater or less depth, complete at its circumference and having a free, complete edge. When connection takes place it usually happens that one or more splits occur in the free margin, but no part of the circumference is lost. As the result of delivery, if at term almost invariably, and often even when the patient has not reached the full time of pregnancy, parts of the hymen become lost; it is then represented by little pieces left at the circumference with vacancies between them, and

of course the whole vulva becomes at the same time more distended than it was before. Parts of the hymen may also be lost on account of inflammatory disease and ulceration and sloughing, syphilitic or otherwise. The hymen may be thick and fleshy, instead of thin and membranous; and such a hymen is very likely to resist laceration during connection, and occasionally even during delivery; especially if the child be small and the patient have not reached the full time of gestation. In another form of virginal hymen occasionally met with the vulva is closed by the membrane, which has, however, small holes here and there in it — the cribriform hymen, as it is called. In other cases the hymen is exceedingly tough and elastic, and the membrane is larger than usual, leaving only a small orifice in front. In such cases also the membrane may escape laceration, but, being distensible, it becomes considerably stretched by efforts at connection. Finally, the hymen may be imperforate; if so, when puberty is reached retention of the menses occurs, and the flow, distending the vagina and uterine cavity, causes the membrane to bulge outwards.

In examining *the vagina*, the size of it, the character of the mucous membrane, the presence of discharge, tendency to prolapse, pessaries or foreign bodies contained within it, and cysts or growths in its wall are to be ascertained.

The vagina in the virgin is much shorter than in persons who have had connection, though it varies much in individual subjects: it is still more enlarged by the process of parturition. The tone of the vagina should be noted; for when the tissues are lax and wanting in tone the vagina may be exceedingly large. Perhaps the largest vaginas we meet with occur in hysterical women, in whom what is known as “ballooning” of the vagina occurs; so far as I am aware no very satisfactory explanation of this condition has yet been given. The vagina may also be capacious in persons who have worn pessaries for uterine displacements or other conditions.

The colour of the mucous membrane of the vagina, as of the vulva, indicates the existence of gestation, the presence of some tumour, or a congested condition produced by more or less general disease or local inflammation. On examination, especially with the speculum, one may come across spots either redder or paler than the general surface of the mucous membrane: the exact significance of these spots, I believe, is as yet unknown.

Ulcers may also be found in the vagina, either of a simple or syphilitic character.

Finally, some discharge may be present, and its quantity, colour, and consistence should be observed. It may be watery; or thick and yellow; or thick and clear like unboiled white of egg; almost jelly-like in consistence; or milky and opaque.

The walls of the vagina are prone to eversion and prolapse. Prolapse of the anterior wall with the bladder (cystocele) is the more common. If this condition be not well marked it may pass unrecognized,

unless the patient be directed to hold her breath and strain down, or she be examined in the standing posture.

Rectocele—a prolapse of the posterior vaginal wall involving the rectum—is less common, though frequently the two occur together. On further straining the cervix will often come down and pass the vulva; and in the worst cases even the fundus will find its way outside, the vaginal walls being completely everted, complete prolapse of the bladder, uterus, and frequently of the rectum as well, taking place. The presence of the bladder outside may be demonstrated by passing a sound into the bladder and observing the position of the point in the prolapsed mass. Rectocele may be recognised by passing the finger into the bowel.

The presence of pessaries or foreign bodies in the vagina will not escape notice. Pessaries are sometimes put into the vagina without the knowledge of the patient; or may sometimes be forgotten and left there for a considerable time. Their presence is apt sooner or later to set up vaginitis, unless the patient takes means to ensure cleanliness by the use of vaginal douches.

Cysts, by no means common, are occasionally found even at the upper part of the passage. A case sent to me as one of small ovarian tumour proved to be a cyst at the roof of the vagina. The wall of the vagina is frequently infiltrated by malignant disease extending from the cervix.

*The cervix* may be outside the vagina, or high up, even out of reach, especially when the bladder is full; it may be just within the vulva; it may be far forwards; it may be backwards on the perineum, or backwards and high up; or it may be to one side or other of the middle line. Its shape is to be noted. The length of the vaginal part of the cervix—the part, that is, which projects into the vagina—must be observed; its consistence also; its mobility, whether it appears to be free or attached and limited in its movements; the condition and colour of the mucous membrane will be seen by using a speculum (generally, for purposes of diagnosis, a Fergusson's speculum); as also any erosion on one or other lips of the cervix, or ulceration; and, finally, the secretion passing from the cervix.

In speaking of the conditions which cause the position of the cervix to vary I must anticipate a little, for the position of the cervix has often to be considered in relation to the position of the fundus. The cervix is lower than it should be in cases of prolapsed and of procident uterus, and in supravaginal and infravaginal elongation; but when the uterus is merely prolapsed or procident the fundus falls with it, and their relative position is preserved. In cases of infravaginal elongation, in which the cervix is usually lengthened out into a cone surmounted by a small orifice, the fundus maintains its proper position; but the cervix itself is elongated and the canal lengthened. This is a congenital affection usually associated with dysmenorrhœa and, if the patient be married, with sterility also. In cases of supravaginal elongation the intravaginal cervix is not elongated; but the cervix falls while the fundus relatively maintains its normal position, though it is often associated with some descent of the



uterus as a whole: extension takes place between the attachment of the uterus to the parts around and the roof of the vagina. In this case also the canal is lengthened. In ante flexion the cervix usually maintains its position so long as the ante flexion is ante flexion pure and simple; but where version takes place the cervix is found higher up and farther back than usual. In retro flexion pure and simple the cervix maintains its position though the body fall; but when retroversion takes place the cervix approaches the symphysis while the body tilts backwards. Ante flexion is not infrequently found in association with retroversion, in which case the body falls in the pelvis, and at the same time the cervix approaches the symphysis and its orifice becomes directed forwards, often looking towards the top of the symphysis instead of downwards and backwards. Irregularity of the cervix may be the result of laceration occurring during delivery or in the course of an operation. Lacerations occurring during parturition are more frequently found on the left than on the right side, and if both sides are involved the left is usually more so than the right. Where, too, bilateral laceration has occurred, the lips of the cervix may become averted so that they actually fall into the same plane. All cases of flexion and version are apt to be accompanied by some descent of the uterus as a whole. Carcinoma produces more or less irregular nodulation either in the substance of the cervix or on its surface, which imparts to the examining finger a gristly feel. A cauliflower excrescence springing from the cervix may be at once put down to malignant disease. In consistence the cervix may be rendered much harder than usual by chronic inflammation set up in consequence of lacerations and tears, such as occur after repeated deliveries, especially where instruments have been used. Primary syphilitic sores are rarely found on the cervix, but when present preserve their usual hard character. The cervix is rendered hard also by malignant disease which, after a time, breaks down towards the centre, still leaving a hardened infiltrated margin. In consistence it is diminished in pregnancy, in subinvolution, and in many cases of inflammation of the lining membrane, especially when associated with hæmorrhage and copious discharge. The mobility of the cervix may be diminished either from the presence of some extraneous tumour pressing the uterus downwards or to one side; or as the result of some inflammatory condition with effusion, adhesion, or cicatricial contraction resulting therefrom; or, finally, as the result of cancerous growth in its substance which has spread and involved the cellular tissue outside. The mobility is abnormally increased when the parts are lax and the ligaments have become stretched, as occurs in cases of prolapse, procidentia, etc.

The colour of the mucous membrane will indicate congestion or inflammation. In cases of metritis it becomes of a florid red colour; its colour is dull or bluish when the blood-supply is partially arrested, either from incomplete strangulation, as in prolapse; or from the pressure of tumours in the pelvis or abdomen; or as the result of inflammatory effusions, or of obstruction to the circulation in disease of the heart and

liver. In prolapse of the vaginal walls the mucous membrane after a time becomes thickened and the surface dry.

Erosions vary much in appearance. Sometimes they are florid; sometimes they are œdematous and readily bleed when touched. When healing they take on a bluish line at the margin: the part which has healed over, which has become cicatrised, that is, with a stratified layer of epithelium, is of a whitish-bluish colour, different from the rest of the cervix. Proliferation of the gland structures often takes place; the follicles become distended with mucus, and, the ducts being plugged, the follicles stand out as glistening points dotted over the surface of the erosion.

Simple ulceration is uncommon, except as the result of laceration or of caustic applications. Syphilitic ulceration—a hard sore of the cervix—is occasionally met with and has the same characters as hard chancres elsewhere.

The secretion from the cervix is naturally a thick glairy mucus, but in cases of severe inflammatory mischief it often becomes purulent.

The presence of mucous polypi in the cervix itself, growing from the lax mucous membrane, is usually associated with a very considerable amount of secretion from the canal and often with hæmorrhage.

*The body of the uterus* may present changes in size, shape, consistence, or mobility; and it may be tender to the touch.

The displacements of the body which may be met with are prolapse—that is to say, a falling downwards, which, when existing to a marked extent, is known as procidentia; anteflexion; retroflexion; anteversion and retroversion; and a combination of anteflexion and retroversion. Lateral displacements may sometimes be observed, especially where a growth or swelling in the broad ligament displaces the uterus to the opposite side, or adhesions draw it to the same side. But lateral displacement may be congenital from a shortening of the ligaments on the side to which it is inclined. Extraneous tumours may displace the uterus downwards—as does ovarian disease, which frequently at the same time produces retroversion; upwards—as does especially a full bladder; forwards—as by any swelling in the pouch of Douglas, such as hæmatocele, or a mass of fæces in the rectum; backwards—as again by a full bladder or ovarian cyst; and laterally—as by any swelling in the broad ligament itself, such as an extra-uterine gestation, a parovarian swelling, or sometimes a small ovarian tumour.

The uterus may be found of less than normal dimensions; either as a congenital defect, in which case the ovaries may also be absent or imperfectly developed; after delivery as the result of what is known as superinvolution; or at the menopause, as the result of natural atrophy.

The uterus frequently increases in size. For purposes of diagnosis it is well to divide these enlargements into those which are regular in character, and those which are of an irregular form. Uniform or regular enlargement occurs in gestation; and, of course, such enlargement is also met with after delivery, in the lying-in period, before the uterus has

returned to its normal dimensions, and in cases of subinvolution. In cases of inflammation (metritis and endometritis) the uterus is increased in size; the sound usually passes half an inch to an inch more than the natural distance. In cases of mole pregnancy a regular enlargement of the uterus occurs; though occasionally an irregular bulging may be found—especially in blood mole—over the site of the effused blood. Again, more or less regular enlargement of the uterus takes place in cases of pyometra and hæmatometra; cases, that is to say, of pus and blood inside the uterine cavity. Pyometra is usually met with in old women, but is not a common condition; hæmatometra, as a rule, belongs to cases of imperforate hymen.

Among irregular enlargements of the uterus, myomas or fibroid growths are the most common. Cancer of the uterus also produces more or less irregular enlargement of the body; though it may appear uniform, as it may also in enlargement due to fibroid. Cancer of the body, in comparison with carcinoma of the cervix, is a rare disease, occurring late in life. Sarcoma of the body, another rare condition, also produces more or less irregular enlargement.

As regards consistence, we may take it as a general rule that soft enlargements of the body of the uterus are usually the result of gestation, when, be it noted, there is a hard body inside the fluid one. In hydatidiform mole enlargement takes place rapidly and is of a soft character. In subinvolution the consistence is diminished; and the same description usually applies to metritis unless it has become chronic; and also to pyometra and hæmatometra, unless the distension be very great, in which case the enlarged organ is hard. In rapidly growing fibroids and fibro-cystic swellings the enlargement is usually soft and semi-fluctuating, and a uterine bruit may often be heard.

The enlargements, in which the consistence is increased, are usually the result of fibroid masses, unless rapid growth be taking place or œdema be also present, as for instance when the enlarged uterus becomes impacted in the pelvis. Cancerous enlargements are usually hard; so also are sarcomatous tumours. Blood and fleshy moles (in contradistinction to hydatidiform moles) cause abnormal hardness of the uterus.

In considering the mobility of the uterus, it has to be remembered that it is usually increased, as the result of laxity of the tissues, by frequent child-bearing or by operations in which the uterus has been dragged upon. It is decreased as the result of extraneous tumours preventing free movement, whether these tumours be above, below, to one side, or at the back of the uterus. In cases of inflammatory mischief the uterus may be either pushed to one side by the effused products, or drawn by adhesions to surrounding structures; or, if the effusion have occurred in the cellular tissue; it may be drawn and fixed by the contraction which subsequently occurred. In any case the movements of the uterus are restricted. The mobility is decreased also by new growths spreading and involving the tissues beyond the uterus, as in cancer and sarcoma; or when from any cause the uterus falls into the

pelvis and becomes impacted. In severe cases of retroflexion and of retroversion the fundus may be grasped and held down in the floor of the pouch of Douglas by the sacro-uterine ligaments.

The uterus becomes tender to the touch from congestion, from inflammation of the tissue of the uterus itself, or from such inflammatory mischief, in the immediate neighbourhood, as occurs in ovaritis, prolapsed ovaries with congestion, pelvic peritonitis, and, lastly, as the result of adhesions to surrounding structures.

*Tumours in the Pelvis.* — In investigating pelvic tumours the points to be noted are their position; their size; their shape; their consistence; their mobility; the presence of tenderness on manipulation; and their apparent attachment, which is estimated by endeavouring to move the tumour, and ascertaining upon what parts it appears to drag, and upon what parts the movement of the tumour has no effect.

The tumours in the pelvis may be divided, according to the part from which they originate; into eight heads, as follows. (In this category tumours of the vagina and vulva are not included because those affecting the lower part of the canal have been already mentioned.)

i. Tumours of the Uterus itself are — Inversion, either partial or complete. Fibroid polypi, which may be either in the vagina, lying in the cervix of the uterus and distending it, or still remaining in the cavity of the uterus: myoma of the cervix very frequently grows down into the vagina, occasionally into the broad ligament: myoma of the body of the uterus begins in various parts and grows in various directions as submucous, interstitial or subperitoneal. Fibroids are frequently multiple, and interstitial growths are frequently found in association with a polypus or a subperitoneal fibroid; as they grow, they may extend into the broad ligament, especially when they begin low down or on one side of the uterus, and subperitoneal fibroids are apt to fall into the pouch of Douglas and become impacted there. Cancer of the cervix, subsequently extending to the body as well as to the vagina: primary cancer of the body. Sarcoma of the body of the uterus. The body of the uterus itself, taking up a faulty position, such as has been already mentioned in retroflexion or version, may form a tumour. Retroversion of the gravid uterus impacted in the pelvis must also be mentioned.

ii. Tumours connected with the Fallopian Tubes. — One or both tubes may be distended with serum, pus, or blood, giving rise to hydrosalpinx, pyosalpinx, and hæmatosalpinx respectively; the tubes themselves being usually thickened and adherent. Tubal gestations frequently rupture either into the peritoneal cavity, giving rise to hæmatoecle, or into the broad ligament giving rise to hæmatoma. Occasionally part or the whole of the gestation sac may be extruded from the fimbriated extremity (tubal abortion), or, less often, find its way into the uterine cavity.

iii. Tumours of the Ovaries. — Prolapsed congested ovary, forming a swelling not usually of large size, is by no means an uncommon condition; and is frequently found associated with retroversion of the uterus and general laxity of the tissues. Cystoma of the ovary, that is to say, the



ordinary cystic ovary; dermoid tumours of the ovary, and parovarian cyst, which is really a tumour of the broad ligament, arise in the ovarian region.

iv. Tumours of the Cellular Tissue are hæmatoma, serous effusion, (parametritis), and abscess.

v. Tumours of the Pelvic Peritoneum are hæmatocele; serous perimetritis, that is to say, a localised peritonitis with effusion; and abscess.

Adhesion and the matting together of the intestines, tubes, and ovaries in the pouch of Douglas frequently gives the impression of a distinct tumour in that situation. A loop of intestine containing fæces may easily be mistaken for some other tumour in the pouch of Douglas.

vi. Tumours connected with the Rectum are fæcal accumulation; malignant and other growths.

vii. Tumours connected with the Bladder. — The most common is scarcely worthy to be called a tumour, though it frequently simulates one, namely, distension of the bladder from the accumulation and retention of urine. Stone in the bladder is a very uncommon condition in women, but may occasionally be met with.

viii. Retroperitoneal Growths are such as lipoma, sarcoma, osteoma of the bones of the pelvis; a contracted pelvis.

**II. Examination by means of the Sound.** — For purposes of diagnosis the sound serves as a measure of the length of the uterus, of the size of the canal, and of its direction; moreover, by careful use of it other facts may be inferred, such, for instance, as disease of the mucous membrane from the passage of blood or discharge after its use. To some extent, also, the condition of the canal may be inferred by noting whether its introduction or removal is associated with pain as it passes the inner orifice.

When the sound touches the fundus it usually produces pain which is generally referred to the region of the umbilicus.

In speaking of the conditions which produce increase in length, it must be remembered that after child-birth the uterus rarely returns to the size of the unimpregnated organ; but the difference is usually not more than a quarter of an inch. Elongation of the canal may be due to subinvolution; to chronic metritis; to polypi, submucous and interstitial fibroids; to sarcoma and carcinomatous disease of the body; and to supravaginal and infravaginal elongation of the cervix. Shortening of the canal may be due to partial inversion (in complete inversion it is obliterated); to superinvolution; to the natural atrophy which occurs after the menopause, and to faulty development.

The canal may be congenitally narrow, especially at the inner orifice; or contracted and even obliterated by caustic applications; or as the result of operation, for example, supravaginal amputation. The canal may be dilated in various conditions during pregnancy and after delivery; also by the passage of polypi and from loss of blood. Its direction may be altered by versions and flexions, or by the presence of fibroid or other mass encroaching upon its lumen.

**IV. Examination by the Bladder and Rectum.** — In some cases where a tumour seems to be in the pouch of Douglas, but cannot be well defined, an examination by the rectum may set aside the possibility of its rectal origin; and in many cases examination by the rectum with the finger of one hand may be combined with that by the vagina with the finger of the other. Examination by the rectum is often of considerable use in determining the height of the fundus; the size of the fundus; the size of the body, and the presence or absence of the ovaries and disease of the tubes. In some cases, to determine the size of the uterus or the presence or absence of the uterus from its normal position, it may be advisable to examine through the urethra either with the sound or with the finger; for instance, in some doubtful cases of inversion. If the finger be employed, it is often better to incise the vesico-vaginal septum, which readily heals, than to dilate the urethra with the risk of permanent incontinence. Examination of the bladder may be combined with a digital examination by the rectum.

In all cases I would recommend a bimanual method in making internal examinations; it is accomplished with far greater ease and ensures much greater accuracy.

**V. Additional Means of Examination.** — In some cases, however, it will be found that the means already suggested, even if adopted, are not sufficient to clear up the nature of the case. Especially is this so when the patient is difficult to examine, as in cases of vaginismus; when the parts are contracted; when the patient holds her breath and strains, and particularly when it is necessary to ascertain the exact connections of a tumour in the pelvis, and to determine whether it be freely movable or not. In such cases the advantage of an anæsthetic are very great. In other cases, again, some difficulty arises in passing a sound, which may get fitted into little pouches in the canal. If the passage of the sound be necessary to diagnosis, it is well to fix the cervix with a volsella. This does not necessarily involve the use of an anæsthetic in married women; but it is frequently expedient that the examination may be complete. In the examination of young unmarried women an anæsthetic is often desirable on other grounds.

There are other cases, again, when it is necessary to dilate the cervix and explore the uterus. Dilatation may be effected under an anæsthetic with Hegar's dilators; and it is often called for, not only in deciding the cause of hæmorrhage from the uterus, but also as a preparatory step in operations for its relief. When the cervix is unusually rigid laminaria tents may also be used with advantage.

Finally, it may be necessary, before arriving at a diagnosis, to remove portions of tissue for microscopic examination; as in the case of erosions of the cervix of doubtful malignancy, and in cases of hæmorrhage from the uterus with irregularities of the surface, which may be of a malignant nature; or, again, to determine whether retained products are the result of gestation or of some inflammatory condition of the mucous membrane.

It is not always possible to arrive at a correct diagnosis on first

seeing the patient; time is often an important factor in forming a correct opinion. But while the precise nature of the case remains undetermined the patient may often with manifest advantage be placed under provisional treatment to give relief to her instant sufferings, and to assist the physician in arriving at a complete diagnosis of the case. Take, for instance, the case of a swelling in the pelvis, the nature of which is at first undeterminable. The symptoms and physical signs point to inflammatory mischief; and for a time it may not be possible to distinguish, and to exclude some cystic or other swelling at the bottom of it, such as a ruptured ectopic gestation. The patient is put to bed and kept quiet; hot douches are ordered to allay inflammation; and the bowels are regulated with a view to avoid irritation of the inflamed parts in the pelvis. If, after a time, the temperature, which perhaps was considerably raised, has under this treatment fallen to normal; if the tenderness and pain have gradually subsided or disappeared; if the swelling has diminished in size, and the parts which were previously fixed have become mobile, it may be reasonably concluded that the swelling probably consisted entirely of inflammatory effusion. But such cases do not always end thus. For example, after the temperature has been normal for a week, and the patient has then risen from bed, the inflammatory mischief may reassert itself. We are thus led to think that something more than the mere inflammatory mischief remains behind; and after a time some definite swelling may be recognised. In cases such as these a correct diagnosis can only be reached by care and vigilance. It is important also to have the opportunity of noting any changes in the symptoms and physical signs while the patient is under treatment, and to be prepared to modify the diagnosis according to the results.

ROBERT BOXALL.

#### REFERENCES

1. COHNSTEIN, J. "Die gynäkologische Diagnostik," *Volkman's Sammlung*, No. 89. Leipzig, 1875.—2. KEATING, JOHN M. and HENRY C. COE. *Clinical Gynecology, Medical and Surgical, by American Teachers*, 2 vols. Edin. and Lond. 1895.—3. MANN, MATTHEW D. *A System of Gynecology by American Authors*, 2 vols. Edin. 1887, 1888.—4. PÉAN, J. *Diagnostic et traitement des tumeurs de l'abdomen et du bassin*, 2 vols. Paris, 1880, 1885.—5. VEIT, JOHANN. *Gynäkologische Diagnostik*. Stuttgart, 1891.—6. WELLS, T. SPENCER. *Diagnosis and Surgical Treatment of Abdominal Tumours*. Lond. 1885.

R. B.

---

## INFLAMMATION OF THE UTERUS

Few subjects in gynæcology are so difficult to handle as inflammation of the uterus. Seldom fatal, and therefore not lending itself to the precise methods of the pathologist, its pathological anatomy is being but slowly worked out. Clinically it includes a long series of cases showing

the most varied changes. Beginning with those in which the only symptom is pain, and the only physical sign undue sensitiveness on examination, — cases which led that careful clinician Gooch to describe what he called the “irritable uterus,” — it further signifies groups of cases which show all the marks of local inflammation, but usually present no distinct line of demarcation between the acute and the chronic. Besides being rarely fatal, except in cases of puerperal sepsis, which belong rather to the domain of obstetrics than of gynæcology, another peculiarity of inflammation of the uterus is the rarity of suppuration which is so common a result of inflammation in other organs. We are not surprised, therefore, to find a great divergence of opinion among leading gynæcologists in Britain and elsewhere on the nature and relative importance of the various forms of uterine inflammation.

A retrospect of the opinions held during the last half century on the significance of the various inflammatory lesions in the pelvis brings out two curious facts. The first is the influence of methods of examination in accentuating a lesion. The speculum concentrated attention on the cervix, the sound on the position of the uterus; the bimanual examination on the cellular tissue and peritoneum; the exploratory incision on the uterine appendages, and the microscope on micro-organisms. On the introduction of each of these methods of examination the corresponding lesion has been emphasised out of all proportion to the rest. An expert in any one method of examination is disposed to say—This is the lesion, and there is no other. At present abdominal section and the microscope hold the field; and a historical survey warns us that at the present time we are exposed to the danger of emphasising the significance of inflammatory lesions of the uterine appendages, and even of the part played by micro-organisms, at the expense of other lesions and other factors of no less importance.

Another striking feature in such a retrospect is the progress in the mode of regarding disease. Half a century ago the standpoint was a symptomatic one. Tyler Smith’s book on *Leucorrhœa*, in which the most varied conditions are grouped together because they have this symptom in common, is an illustration of the symptomatic standpoint. At the present day the standpoint is pathological; the “entity leucorrhœa” has been replaced by “endometritis” and “cervical catarrh,” under which names the lesion is localised and described. But the changed standpoint does not simply mean seeing another side of the same thing. We are not merely walking round a hill, we are ascending it; the pathological standpoint is a step higher than the symptomatic; a step higher still will bring us to an etiological standpoint, inasmuch as etiology deals with causation, and is the basis of preventive medicine. Where it has been demonstrated, as in the case of gonorrhœa, that the inflammatory conditions of the uterus are due to a micro-organism, this view of inflammation from the etiological standpoint has simplified our conception of it. Instead of being broken up artificially into different affections according to the tissues involved for the time being, it has



become an organic unity, gathered round the life-history of a micro-organism. Clinical experience tells us that this is the true mode of regarding it.

And yet, if it should be shown that all the changes which we associate with metritis have a microbe at the bottom of them as the essential factor in their production, this would not produce a great revolution in our conception of metritis, although it would materially influence our treatment in so far as it might emphasise preventive treatment by antiseptics. After all the micro-organisms have been discovered and described, attention will again revert to the local and general conditions which determine their growth. If the microbe or spore be the seed the uterus is the soil, and those subtle influences which we speak of as constitution and diathesis are the climate. The seed is an essential factor in plant life, but equally important factors for development and growth are soil and climatic conditions. The discovery of the seeds has for the time thrown the study of constitutional states and diatheses into the background. But because we know little about them we need not minimise their influence. No science is so vague as meteorology, and yet nothing bulks so largely in the farmer's mind as the weather. Of the importance of soil no better illustration could be found than in the case of the puerperal uterus. If Winter's observations are correct, the staphylococcus pyogenes albus, aureus, and citreus, as well as various forms of streptococci, are present beforehand in the uterus, but lie harmless until the puerperal state supplies the conditions favourable for their development.

To Henry Bennet is due the credit of drawing attention to the importance of inflammation of the uterine mucous membrane (2). Although he described it as in many cases going on to ulceration, so that his opponents fastened on the alleged "ulceration," and criticised it as the essence of Bennet's teaching, it is only fair to him to say that he regarded ulceration as but one of many phases of inflammation. Perhaps he laid himself open to criticism by stating that inflammation was to be treated by surgical means.

Bennet's views were opposed by Lee and West (40) and Tyler Smith. In reaping their criticisms it is interesting to come upon statements, then based only on clinical observation, which have since been established by microscopic investigation. Thus Lee, speaking of the appearances which Bennet described as ulceration, says: "These apparent granulations are usually considered and treated as ulcers of the os and cervix uteri, but they do not present the appearances which ulcers present on the surface of the body, or in the mucous membranes lining the viscera, and they are not identical with the granulations which fill up healthy ulcers. They present the appearances often observed on the tonsils which are said to be ulcers, and are not" (21). Thus Lee, writing in 1850, forecasts the work of Ruge and Veit in 1878. The comparison of the "ulcerated" cervix to a hypertrophied tonsil is a happy one. So also Tyler Smith forestalled the view of Emmet and Roser, that the appearance is produced by an ectropion of inflamed cervical mucous membrane, when he

says: "The granulations which are sometimes found surrounding the os uteri — which may secrete mucus or pus abundantly, and which may bleed on being roughly handled — are, I have no doubt, the result of inflammation; but they resemble the granular state of the conjunctiva rather than the granulations of a true ulcer, the granular os uteri offering no edges or signs of solution of continuity, by which we might satisfactorily declare it to be an ulcer (37)."

Unfortunately, and in spite of such criticism, the term "ulceration," introduced by Bennet, took hold of the professional mind. It led to a routine treatment of inflammatory conditions of the cervix by caustics, as slowly healing ulcers in other situations are treated. An erroneous pathology opened the door for a pernicious treatment, from which British gynæcology suffered until it found a true pathological basis.

**Etiology of Uterine Inflammation.** — While for descriptive purposes we divide inflammations of the uterus into inflammation of the cervix or cervical catarrh, of the mucous lining of the body or endometritis, and of the substance of the uterus or metritis, it must be borne in mind that no one of these occurs by itself. Before looking at these conditions separately it will be convenient to consider the etiology of all three together, inasmuch as they are produced by the same causes. Clinically the inflammation is not limited to any one tissue; and all that is meant when a case is spoken of as endometritis, is that the changes in the mucous membrane in the body of the uterus are for the time being more prominent.

In studying the etiology of inflammation of the mucous membrane of the uterus, we must bear in mind that the uterine mucosa is not functionally analogous to other mucous membranes, as for example those of the stomach, the respiratory tract, or bladder. These belong to organs whose function is constant and necessary to life. They are in daily use, while the function of the uterus, namely, reproduction, is only called into exercise occasionally. Even the periodic changes connected with menstruation can hardly be considered as a function necessary to life, for there is no evidence to support the old idea of its being a monthly cleansing or katharsis, which would make the uterus practically an excretory organ. Menstruation is connected with the function of reproduction, and its occurrence is not necessary to life. If then the uterine mucosa be not analogous to other mucous membranes, we must be cautious in transferring to the etiology of its diseases notions gained from the study of pathological processes in these others. Thus we are prepared for the fact that many of the processes which we have to describe under endometritis are more allied to new formation than to inflammation, or at any rate, to the inflammation we are accustomed to study in mucous membranes elsewhere. Were we to subject the heterogeneous mass of pathological conditions grouped under endometritis to exact criticism, much would disappear and the residuum would be small. Thus endometritis fungosa is more of the nature of a new growth than of an inflammatory process; the glandular form of endometritis is more akin to an adenoma than to a

catarrh of a mucous membrane; and many cases of endometritis after abortion should, according to Küstner, be considered as deciduomas.

Pozzi, however, in his admirable chapter on Metritis in his treatise on Gynæcology, justifies the grouping of these varied conditions under Metritis, because they have these features in common — that their commencement is an infective process, and their evolution defensive and limiting in its action. This, however, does not exhaust the features of an inflammation as contrasted with a neoplasm. The final product of an inflammatory process is a degenerated tissue rather than the tissue characteristic of the organ in which it has occurred. Of the former we have illustrations in those forms of endometritis which end in the destruction of the mucosa; of the latter in those which end in hypertrophy.

On the other hand, the uterine mucosa, and especially that of the cervix, is analogous to other mucous membranes in its tendency to be affected in certain diatheses or constitutional states. Thus in tuberculosis and syphilis, in rheumatism and gout, in anæmia and chlorosis, there is a tendency to cervical catarrh as there is to bronchial or gastric catarrh.

We are not yet in a position to classify satisfactorily the causes of uterine inflammation. All we can do, in the present state of our knowledge, is to arrange them in two groups, — those which are constitutional, and those which are local. It is evident that this classification is not satisfactory, because in many cases the factor is a micro-organism which, as it gains access through the mucous membrane, is a local cause, but in so far as the whole system becomes affected by it, is a general cause.

The constitutional causes of uterine inflammation are even more deserving of study than the local causes. Being less obvious, they do not force themselves upon our attention: more subtle in their action, they are more difficult to estimate; and the more their constitutional quality, the more difficult they may be to treat. In scrofula and tuberculosis there is a tendency to uterine catarrh, affecting specially the cervix; as there is a tendency in the same diathesis to bronchial or gastric catarrh. So also in patients suffering from rheumatism and gout, we find a similar tendency, and likewise in girls suffering from anæmia and chlorosis. Apart, indeed, from any special diathesis, a generally enfeebled state of the constitution will bring out tendencies to cervical catarrh, as it may to tonsillitis. Hence the gynæcologist must direct his attention to those modes of life which tend to undermine the health. Once we fully appreciate the connection between the general health and local conditions, we shall make out a strong case against the current mode of bringing up young girls, especially during the years of school education. The present system undoubtedly favours the development of menstrual disturbances which frequently end in uterine inflammation.

Passing from constitutional states to specific diseases, we find that the uterine mucosa, like other mucous membranes, is affected in the course of the exanthemata. Thus in measles, scarlatina, and small-pox, as well as in typhoid fever and cholera, endometritis is liable to occur.

In the recent influenza epidemic menorrhagia was a not infrequent symptom. Gottschalk found hæmorrhages in the uterine mucosa in influenza, but no microbes. Organic diseases which favour passive congestion also lead to inflammatory changes in the uterus. Thus in diseases of the heart and kidney, and especially of the liver, uterine inflammation may be present, and can only be dealt with by recognising and treating the primary affection.

Inflammation of adjacent organs excites inflammatory changes in the uterus, apart from simple extension of inflammation. This occurs in inflammation of the uterine appendages, and especially of the ovaries. Czempin, who has studied this point in patients in Dr. Martin's clinique in Berlin, mentions four kinds of such causes: inflammation of the ovaries with or without that of the tubes; old parametritis which has become acute; irritation of the peritoneum, as in cicatrices after Tait's operation and ovariotomy; and other slowly developing conditions of the appendages, such as pyosalpinx and sarcoma of the ovary. Should an etiological relationship be established between disease of the appendages and uterine inflammation, it will give additional reason for the removal of the former when diseased.

Irritation of the rectum also keeps up uterine inflammation, and the latter has been known to disappear on removal of a rectal polypus.

Passing now to the local causes, we note the importance of exposure to cold or great fatigue at the menstrual period. If a woman take a chill during menstruation its effects will probably appear in the pelvic organs. And apart from undue exposure, the congestion of the menstrual periods plays a very important part in the exacerbations of uterine inflammation.

The ovaries play a special part in the development of endometritis. Brennecke, who has drawn attention especially to this point, makes one group of cases of endometritis fungosa arise under their influence. These cases are characterised at the outset by amenorrhœa for one or two periods. This he explains by the ovarian stimulus, which, while exciting the hypertrophy of the mucosa which precedes normal menstruation, is insufficient to cause hæmorrhage. Thus arises a hyperplasia of the mucous membrane from which hæmorrhages afterwards occur. I have not seen any cases of endometritis beginning with pathological amenorrhœa, such as Brennecke describes, but have always been able to account for the amenorrhœa by an early abortion. On the other hand, the irregular bleedings at puberty point to a tendency to endometritic changes in connection with the initiation of the functions of the ovaries.

Pelvic congestion, due to excessive sexual intercourse or to masturbation, is also given as a cause of uterine inflammation. In prostitutes cervical catarrh is common, but this is probably the result of gonorrhœal infection.

Septic infection occurs usually in connection with the puerperal state, whether after abortion or labour. In this state we have a combination of circumstances favourable to septic infection; namely, raw surfaces,



dead matter liable to decompose, and low vitality of the tissues. It is, therefore, in the puerperal state that we find the best examples of acute metritis, and in connection with it the pathology of the malady has been chiefly studied. Hence acute metritis as described in the text-books concerns the obstetrician rather than the gynæcologist. The pathology of the chronic forms of uterine inflammation which come under the attention of the gynæcologist is being worked out but slowly; they are, however, likewise septic in origin. This is a fact which cannot be too much insisted on, as it gives the reasons of the treatment which is here preventive, and consists in carrying out thorough cleanliness with antiseptics in all gynæcological work. The activity of germs depends in part upon the media in which they are cultivated. Some that have lost their virulence regain it in a favourable soil. And the post-partum uterus is practically an incubator, at a suitable temperature for their development, containing the necessary pabulum in the form of retained decidua or blood-clot; we can therefore understand how the microbes may multiply and become virulent there. Abortion, even more frequently than full-time labour, is the starting-point of uterine inflammation, owing in part to the greater tendency to retention of portions of the ovum, and in part to the fact that patients do not take the same care of themselves after abortion. Lacerations of the cervix [see "Morbid Conditions of the Female Genital Organs resulting from Parturition" in this System], which occur in abortion as in labour, form channels for septic absorption and consequent cervical catarrh; and in a large proportion of cases we may trace the inflammation back to such causes. The interior of the uterus after delivery also is practically a large raw surface; hence endometritis in multiparæ can often be traced back to the puerperium. The term subinvolution, introduced by Sir James Simpson, covers all the changes in the cervix, the endometrium, and the body of the uterus thus produced during this period.

Besides acting as foci for the production of septic material, portions of retained decidua occasionally cause endometritis by maintaining their vitality instead of breaking down in the lochia. In such cases islets of decidual cells have been described in the inflamed endometrium. We have thus a form of endometritis after abortion which is a new formation rather than an inflammation, and which can only be treated by the curette.

The introduction of septic matter by the gynæcologist in his use of septic sounds or tents, or the neglect of antiseptics in operations, need only be mentioned as sources of uterine inflammation which should not exist, and which are becoming rarer as the importance of antiseptics is generally recognised.

If in fertile women puerperal sepsis is the most important cause of uterine inflammation, in sterile women the ravages of the gonococcus are deserving of careful study. While those who have written on gonorrhœa certainly convey the impression of exaggerating its frequency, it is nevertheless a malady which, in its subtle invasion and its far-reaching

effects, requires careful investigation. Of these effects sterility is the most important. When patients seek advice, many years after marriage, on account of barrenness, persistent leucorrhœa, menorrhagia, and dysmenorrhœa, symptoms all dating from the time of marriage, the possibility of gonorrhœal infection must be kept in mind. Here also we note the importance of the etiological standpoint; for if we can be sure of the cause, the whole case, as regards both diagnosis and treatment, assumes a different complexion.

Uterine inflammation as the result of displacements is of interest, as it gives us the clue to the difference in the opinions of gynæcologists concerning the significance of these lesions. Where retroversion has not interfered with the involution of the uterus during the puerperium the displacement is symptomless; but if endometritis and chronic metritis be present, we have then symptoms due to these pathological conditions. Chronic metritis and endometritis are by no means such invariable accompaniments of retroversion as they are of prolapse, in which there is always some hypertrophy due to their presence. For the full discussion of the relation of displacement to inflammatory conditions, see the chapter of this work on "Displacements of the Uterus."

Chronic metritis and endometritis also accompany fibroid tumours of the uterus and mucous polypi, as described in the chapter on "Simple Growths of the Uterus."

We pass now to the various forms of inflammation, dividing them, according to the seat of the lesion, into (A) Cervical catarrh; (B) Endometritis; and (C) Metritis.

*The cervix* is sufficiently distinct from the body of the uterus to justify its being treated separately. Structurally it is quite different from the latter: on its vaginal aspect it is covered with squamous epithelium resting on papillæ of connective tissue, and without mucous follicles; its canal is lined with a single layer of cubical epithelium so folded as to form shallow recesses with racemose mucous glands; its mucous surface differs, therefore, from that lining the body of the uterus. Its muscular tissue is not arranged in layers, but consists of fibres scattered irregularly through the connective tissue which preponderates. Functionally, it differs from the body in that it plays a passive part in menstruation and pregnancy. Pathologically, it differs in that the tumours which are common in it are rare in the body of the uterus, and conversely. We are therefore prepared for the fact that chronic inflammation of the cervix may not spread to the body of the uterus. Though clinically we frequently find cervicitis accompanied by inflammation of the body, yet the fact that this association does not by any means invariably occur warrants our considering the cervix by itself.

An anatomical and pathological basis for classification of the various forms of uterine inflammation is preferable to a purely clinical one. As an illustration of the latter, we have Pozzi's classification according to "the dominant clinical characteristic." He thus describes (i.) Acute inflammatory metritis; (ii.) Hæmorrhagic metritis; (iii.) Catarrhal me-

tritis; (iv.) Chronic painful metritis. While agreeing with all that he says as to the artificial nature of the various classifications of varieties of uterine inflammation, and agreeing with him also on the importance of the clinical standpoint, we question whether merely to select a prominent symptom as the basis of classification, is an advance in our method of classification. Though much can be said in its favour, it is practically to return to the symptomatological standpoint regarding disease.

**A. CHRONIC CERVICAL CATARRH.** — Acute cervical catarrh can seldom be studied as a separate condition. It occurs as part of the general inflammation of the uterus seen in puerperal sepsis, and is often the initial stage of the chronic affection, from which, however, it is not marked off.

Chronic cervical catarrh is one of the most important conditions which the gynæcologist has to treat. Matthews Duncan said that, according to its gravity, it would not be placed higher than the third rank; but that on account of its frequency it ranks with chronic ovaritis and chronic inflammation of the uterus.

**Clinical History and Symptoms.** — The patient, usually a multipara, comes complaining of a weak back and “whites.” The pain is generally found to be in the sacral region, the seat of sympathetic pain for the cervix; sometimes it is a sense of dragging or bearing down on the pelvis.

The white discharge may simply be an exaggeration of the normal secretion of the cervix, which is viscid and opalescent, or it may be yellow and purulent. In the former case it is difficult to draw the line between the normal and the morbid, as many women normally have a certain amount of leucorrhœal discharge, especially after the menstrual period. The discharge may have probably lasted some time, unless suddenness of onset with urinary symptoms, which is often suggestive of a gonorrhœal origin, lead her to seek advice at once. The most striking feature of cervical catarrh is its chronic character; the condition is one which sometimes lasts for years. The patient may show one of the constitutional conditions referred to under etiology, such as anæmia or the gouty diathesis; and the more remote causes leading to the congestion of the uterus, as of other organs, should always be inquired into. The symptoms will most frequently be traced back to child-birth or abortion, sometimes to exposure to cold or undue fatigue at a menstrual period, or to the commencement of gonorrhœal infection. In acute cases urinary complications are often present. Menstruation is some times profuse and painful, which is probably due to accompanying endometritis — just as the pain in sexual intercourse, which is sometimes complained of, may be explained by associated parametritis; the cervix uteri itself is not sensitive. If the condition have persisted for a long time symptoms of general weakness come on. The patient complains of lack of energy and of being easily tired, and she may have a poor appetite and slow digestion. Sterility is also present in some cases, although it is difficult to say whether this is due to a plug of mucus in the cervix or to some affection of the mucous membrane higher up in the genital tract. The

explanation of the sterility is more probably vital than mechanical, as the discharge affects the vitality of the spermatozoa.

**Pathology in Relation to Physical Signs.**—Pathology renders a peculiar service to the clinician in giving him a basis for physical diagnosis. It accounts for appearances which he has noticed clinically. The study of disease is the study of a life history. At each successive stage in its progress the pathologist steps in and gives a physical basis for each sign and symptom. He clears away the crumbling remnants of a broken-down hypothesis, and enables the clinician to put his foot down on the rock of anatomical fact. We consider pathology, therefore, in its relation to physical signs.

Nowhere has this service of pathology been more strikingly illustrated than in the physical diagnosis of cervical catarrh. The use of the speculum to determine the source of the discharge shows a red granular surface round the os externum, which bleeds easily. Though more difficult to use, Sims' speculum is superior to either the bivalve or tubular one, because it disturbs less the normal condition of the parts, and enables us to judge of the presence of laceration and the amount of ectropion.

The surface looks like an ulcer, because it is red, granular, and bleeds; and looking like an ulcer it was called an ulcer, and treated by surgical methods as ulceration. Notions derived from ulceration of the skin were imported into the region round the os; and herpes, pemphigus, varicose ulcers, and cockscomb granulations were described. The condition round the os was dissociated from the catarrhal inflammation within the canal, or was regarded as secondary to it, the irritating leucorrhœa causing destruction of tissue. The term ulceration not only suggested a wrong treatment, but gave the condition an undue importance in the mind of the patient.

All this was changed by the microscopic work of Ruge and Veit (30), who showed that the apparently



FIG. 44.—Section of a catarrhal patch (so-called ulcer) on the vaginal aspect of the cervix. The free surface is covered with a single layer of columnar epithelium. It is folded into papillary elevations. Below the surface are gland spaces cut across which may become dilated so as to form retention-cysts.

raw surface is covered with epithelium, and that the granular points are new formations which have no relation to the granulations of an ulcer. The microscopic characters of the mucous membrane, to be readily understood from Fig. 44, which represents a clipping from one of these catarrhal patches, are as follows. The surface is covered with a single layer of epithelium, the cells are smaller than those which line the normal cervical canal, and being narrow and long, have a palisade-like arrangement. The thin layer of cells allows the subjacent vascular tissue to shine through, hence the red appearance of the surface. The surface is further thrown into numerous folds producing glandular recesses and processes. These processes cause the



granular appearance of the surface. If the recesses be long and narrow, the surface is split up into distinct papillæ. This constitutes the papillary erosion. If the ducts of the glandular recesses become obliterated, the secretion distends the glands below and produces retention-cysts; these increase in size, and may come to the surface and burst. Thus is formed the follicular erosion.

The raw-looking surface is therefore a newly formed glandular secreting surface, which in structure resembles the cervical mucous membrane. This addition to the extent of secreting surface increases the leucorrhœal discharge, which is the leading symptom. The so-called ulceration is thus seen to be simply a part of the process of cervical catarrh, and this not the most important part. If the cervix have been lacerated the swollen mucous membrane causes a gaping of the cervical canal at the cleft; and thus we may be misled as to the extent to which the catarrhal patches spread beyond the os externum. By rolling in the everted lips with the tenacula until the laceration closes we can estimate the probable position of the os externum.

From this it is evident that the process is not one of ulceration, and the term should be abandoned. The German term "erosion" is open to similar objections. "Ectropion" or "eversion" of the mucous membrane describes the condition in its relation to laceration, but does not describe the extension of the secreting surface beyond the os externum. The term is preferable to ulceration, however, as it is not so misleading. Thomas describes these conditions under the name of granular and cystic degeneration of the cervix uteri, and Palmer makes a compromise between the new and the old by treating of them under the title of "ulcerations and degenerations of the cervix uteri." We are not yet in a position to introduce a term based on pathology, even if it were desirable to give to this appearance a special name, and thus to suggest a difference in nature from the inflamed mucous membrane in the canal. Probably the best name for these red patches lying outside the os externum is "catarrhal patches," as it suggests that they are portions of the mucous membrane in the same catarrhal condition as that lining the cervical canal.

Fischel and other observers have confirmed these observations of Ruge and Veit in their essential points. Fischel considers, however, that the secreting processes, though new formations, have the structure of papillæ, and are not mere foldings of the mucous membrane.

While there is, therefore, no disagreement as to the microscopic appearance of the so-called "ulcerations," the origin of this new epithelial structure is disputed. Ruge and Veit hold that this single layer of small cylindrical cells is produced by proliferation of the cells of the deepest layer of the rete Malpighi, while those of the superficial layer are shelled off. It will be observed also that they regard the simple follicular and papillary "ulcerations" as the results of one and the same process, namely, proliferation of epithelial cells. On the other hand, those red patches are generally continuous with the mucous membrane of the cer-

vical canal, and resemble it in their microscopic structure. It is therefore much more probable that they are occasioned by proliferation of the epithelium which lines the cervical glands, leading to an extension of the glandular surface beyond the os externum. Fischel holds that there is not only a proliferation of epithelial cells, but of connective tissue also, and that as the one or the other preponderates the follicular or papillary forms are produced. He also thinks that erosions are due to the persistence of the cylindrical epithelium (found outside the os externum in the fœtus) into adult life, and to the desquamation of the squamous epithelium which had come to cover it.

The question of the origin of the cylindrical epithelium found in erosions is rendered more difficult by the fact that the boundary-line between the squamous epithelium outside the cervical canal and the cylindrical within it varies at different periods of development and in different individuals. In the fœtus, according to Ruge's investigations, the cylindrical epithelium extends beyond the os externum; and we have a hint of the persistence of this fœtal condition in the congenital ectropion described by Fischel. Klotz describes two types of cervix distinguished by the distribution of the squamous epithelium: one, cavernous in texture, and having the squamous epithelium extending some distance into the cervix; the other, glandular in its substance, and having the squamous epithelium stopping at the usual seat of the os externum.

The foregoing description is based on what is found in multiparous patients in whom the cervical changes, as seen through the speculum, are obvious. In nulliparous patients cervical catarrh may manifest itself by catarrhal patches beyond the os externum, but more frequently the vaginal aspect of the cervix, though soft and swollen, looks healthy. The mucous membrane within the canal, however, is in a similar condition to that described above. The os is sometimes unusually small, and the cervical canal becomes distended with the secretion.

The diagnosis of cervical catarrh is comparatively easy, the cervix being accessible to examination. The condition found on vaginal examination varies as the patient is a nullipara or a multipara. In the former case the cervix feels enlarged and softened, and when there is extension of the catarrhal area beyond the os externum the margins of the os are soft and velvety. In a multipara the os will probably be notched by old lacerations, and may be so patent that the tip of the finger can be passed into the cervical canal. The area round the os is soft and velvety, or rough and granular; and when the Nabothian follicles have been converted into retention cysts, these are felt as small nodules, like peas or shot, in the mucous membrane. Polypoidal projections may be present, and, more rarely, the whole cervix is converted into a cystic mass. The speculum can now be used to confirm what the fingers have felt, and is absolutely necessary in training the finger to recognise the various conditions present. The extent of catarrhal area, the amount of eversion, and the appearances corresponding to the velvety, granular, and nodular feelings are demonstrated by it. But once the finger has been educated,

the speculum, for diagnosis at any rate, comes to be less and less used. When it is desirable to determine the extent of lacerations with a view to operative procedure, tenacula are useful to roll in the everted lips of the cervix. The sound is only of service in diagnosing catarrh in nulliparæ, where it may show a cervical canal unusually dilated by accumulated secretion.

Under differential diagnosis we have only to consider the diagnosis of cervical from vaginal or uterine leucorrhœa, and of simple induration of the cervix from syphilitic ulceration and commencing malignant disease.

The normal secretion from the glands of the cervical canal is clear and viscid, resembling unboiled white of egg; and it is alkaline in reaction. It may be of an opaque white due to an escape of mucous corpuscles, or yellow when pus corpuscles are present. Frequently it is tinged with blood. In the worst cases of catarrh the discharge is a thin yellow or greenish pus. The diagnosis of cervical from vaginal leucorrhœa is made by the speculum, for in the former case we see the leucorrhœa, with the characters above mentioned, coming from the cervix; or by Schultze's method of placing a tampon at the os externum to catch the cervical secretion. The diagnosis of cervical from uterine leucorrhœa is more difficult. Menorrhagia, with increase in the length of the uterine cavity and irregularities in its mucous membrane, point to the presence of endometritis.

Syphilitic ulceration of the cervix is extremely rare, and the history, with the indications of syphilis in other parts, makes diagnosis easy. On the other hand, the diagnosis from commencing malignant disease is exceedingly difficult. If we are dealing with a case of advanced carcinoma, in which ulceration has occurred, there is no difficulty; the finger at once recognises the friable bleeding surface with firmer margins, and the infiltration of the cellular tissue causing fixation. If, however, the cervix be simply nodular, and ulceration has not occurred, it may be impossible to say at this stage whether the case be one of cancer or not. Bennet drew attention to the fact that the lobulation of the cervix in chronic inflammation was more regular, the furrows radiating from the cervical canal being in fact old lacerations, while in cancer the lobulations are irregular. According to Spiegelberg, when a tent is placed in a cervix affected with malignant disease the infiltrated parts do not dilate like normal tissue. This subject belongs, however, to the diagnosis of commencing cancer, for which the chapter of this work on "Malignant Diseases of the Uterus" must be consulted.

**Treatment.** — The importance of constitutional treatment must be fully recognised, as there is no doubt that far too much attention has been given to local treatment. In most essays on the treatment of cervical catarrh we find pages given to local applications and to operative procedure, while general treatment is dismissed in a paragraph. This makes the local, as against the general treatment, bulk far too largely in the mind of the practitioner. While, on the one hand, it may be argued that there will always be a class of patients who are not satisfied unless something is being done directly for them, we must remember that, on

the other hand, irreparable harm often results from lines of treatment which direct the patient's attention to the pelvic organs.

The care of the patient's general health is to be put in the forefront. Change of air, light nourishing food, and a certain amount of exercise are beneficial; and cold hip-baths in the morning are of service. Disturbances of the digestive system, which are frequent in chronic cases, must be carefully treated. Where rest from sexual activity is desirable, this is often secured by recommending that the patient leave home for a time. Tonics, such as arsenic, quinine, and iron, are useful. Sir James Simpson recommended arsenic, believing that it acted beneficially on the cervix as it does on skin eruptions.

The diathesis should also be carefully studied. In strumous or gouty patients, for example, cervical catarrh is simply one of many manifestations of the constitutional state, and is only of significance as directing our attention to it.

Of local applications the most important is the vaginal douche. This treatment, as well as the mode of applying various therapeutic agents to the uterus, is described in the chapter on "Gynæcological Therapeutics"; so that here mention need be made only of special points bearing on their use in uterine inflammation. The douche, to be effective, should be given by means of a douche-can, and consist of not less than a quart of water. The patient should be semi-recumbent. The temperature of the water must be adapted to the individual case: if pain or hæmorrhage be present the hot douche is preferable. The douche is given for cleanliness, and for the application of antiseptics and astringents. Corrosive sublimate (1 to 4000) is very useful in chronic catarrh, especially if a gonorrhœal or septic taint be suspected. Sulphate of zinc (1 dr. to a pint), sulphate of alumina or sulphate of copper (2 drs. to a pint), are also beneficial. The action of these on the catarrhal patches has been specially investigated by Hofmeier, who found that the pale, squamous epithelium gradually crept in tongue-like processes over the red patch. Fig. 45 shows how the superficial glands become filled up with squamous epithelial cells. The deeper glands have their ducts narrowed or even plugged while the gland cavity persists below. Küstner found similar changes produced by antiseptic douches.

Medicaments may also be applied on vaginal tampons, the best excipient being glycerine. The glycerine itself acts by withdrawing serum from the engorged tissue. To it may be added boric acid (50 per cent), tannin (1 dr. to 1 oz.), ichthyol (10 per cent), and iodoform.

Applications may also be made on forceps dressed with cotton wadding, dry wadding being used first to swab off the mucus. Churchill used a preparation of iodine consisting of 75 grains of iodine and 90 of potassium iodide in 1 ounce of alcohol. Weak solutions of nitrate of silver are also beneficial.

Where the cervix is much indurated and studded with retention-cysts, scarification is very useful; it acts by depletion, and also by letting out the inspissated mucus. Bleeding by scarification has largely



taken the place of leeching. Various scarificators have been devised, but an ordinary bistoury does perfectly. A tepid douche given afterwards promotes bleeding. Scarification is preferable to the actual cautery, which has been recommended by Prochownik, as the latter is followed by cicatrisation. In very chronic cases the only remedy is to destroy the diseased glands, as we excise the tonsils in tonsillitis: this is done by caustics, the curette, or the knife. Of caustics, potassa-fusa was recommended by Sir James Simpson, and the zinc-alum sticks of Skoldberg by Matthews Duncan. This use of caustic must be distinguished from the application of it to touch the so-called ulcer so as to make it heal, and has many advocates. It is better to use the curette, as recommended by Thomas, or the knife as in Schroeder's operation (32). In fact, where the glandular tissue has to be destroyed, the most

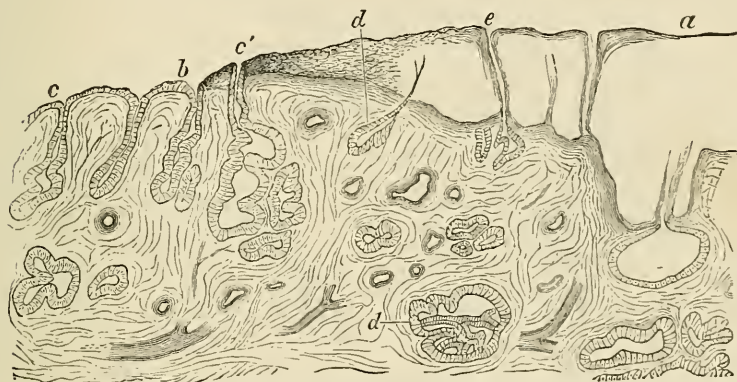

FIG. 45. — Healing of a catarrhal patch treated by astringent or antiseptic injections (Hofmeier). From *c* to *b* is seen part of a catarrhal patch (compare Fig. 44) which from *b* to *a* has become covered over with newly formed squamous epithelium; *dd*, glands whose ducts have been obliterated; *e*, gland duct which has persisted.

efficient and cleanest way of doing it is by excision of the mucous membrane, although the cases in which this operation is called for are comparatively rare. In Schroeder's operation the cervix is laid hold of by two volsellæ, one on each lip, and drawn downwards. It is then divided laterally, as far as the fornix, with the seissors, so as to form an anterior and posterior lip which are separated as far as the vaginal roof. A transverse incision (seen in section at *a*, in Fig. 46) is made across the base of the anterior lip dividing the whole thickness of cervical mucous membrane. The point of the lip is next pierced at *c*, and the knife pushed in the direction *bb* till it reaches the cross incision *a*; the blade is then carried outwards, first to the one side and then to the other, so that all outside of the line *a, b, c* is removed. The flap of the cervix is now turned in and stitched (Fig. 47), and the angles of the wound in the fornix closed.

Emmet's operation is also useful in cases of deep laceration, espe-

cially where there is cicatricial tissue at the base of the cleft: it has not fulfilled all that was expected of it, however, and it is not performed nearly so frequently as was the case some years ago. It simply conceals, without removing the diseased mucous membrane, and should always be combined with measures directed to the treatment of the catarrh.

For marked hypertrophy of the substance of the cervix amputation is the only treatment.

In the cervical catarrh of nulliparæ, where there is a narrow os externum, the bilateral division of the cervix is of service. It allows the secretion to escape instead of accumulating; and applications can be made to the cervical canal. It is also said to favour the occurrence of conception.

These operations are described in the chapter on "Plastic Gynæcological Operations."

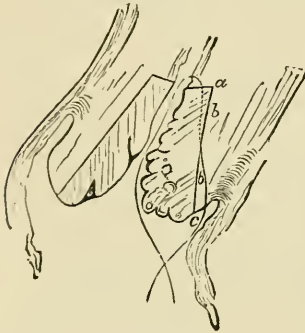

FIG. 46.



FIG. 47.

Schroeder's operation for excision of the cervical mucous membrane in cervical catarrh. Fig. 46, line of incision in mucous membrane; Fig. 47, mucous membrane excised, and flap *bc* turned in on *ab*.

**ACUTE METRITIS AND ENDOMETRITIS.**—In the acute condition we cannot separate these two affections. Clinically they are met with in the puerperal state, and as exacerbations of the chronic condition to be described presently. Except in the puerperal state they are never fatal, and hence the classical descriptions which are handed from text-book to text-book belong to a treatise on puerperal fever rather than to a system of gynæcology.

Wyder (44), from a study of the membrane exfoliated in cases of membranous dysmenorrhœa, has recently described the pathological changes which he regards as those of acute endometritis. The cells in the stroma are greatly increased in numbers, and are so closely packed together that little of the matrix is seen. Gottschalk, on the other hand, finds in the exfoliated membrane changes characteristic of a hæmorrhagic interstitial endometritis. Membranous dysmenorrhœa, or, as it has been called, exfoliative endometritis, is a rare affection,

and its pathology can hardly be considered to be the same as that of acute endometritis.

**B. CHRONIC ENDOMETRITIS.** — This is a sufficiently well-marked condition to merit separate treatment. I would limit the term to those cases in which the patient has the general symptoms of chronic uterine inflammation, which I shall describe under chronic metritis, with in addition increased discharge either of blood at the menstrual period, or of leucorrhœa in the intervals. As the presence of either of these symptoms points to changes in the uterine mucosa as the more prominent condition, there is sufficient reason for treating chronic endometritis as a condition distinct from chronic metritis.

**Clinical History and Symptoms.** — The history may be traced back to abortion or labour, to an attack of uterine inflammation as the result of chill, or to gonorrhœal infection. In a considerable number of cases, however, the symptoms begin insidiously, and develop gradually without any assignable cause. Endometritis is more frequent in multiparous patients, and more common later than earlier in life; though it also occurs in nulliparæ, especially when there is stenosis of the os externum. Ruge describes one-half of his cases as occurring after forty years of age (29). After the menopause a senile form of endometritis may appear, which has to do with the retrogressive changes taking place at that time in the uterus.

The symptoms characteristic of endometritis are leucorrhœa and menorrhagia. The secretion from the body of the uterus is less viscid than that from the cervix, and may be clear; but more frequently it is muco-purulent. It may be tinged with blood so that the patient believes herself to be more or less continually unwell. Sometimes it comes away more freely than at others, as if it collected in the uterus, or as if there were hypersecretion at intervals. It may be so irritating as to excoriate the vulva.

Menorrhagia is generally present, but not always. In some cases the loss may be so considerable as to suggest malignant disease, and even to endanger the patient's life by profound anæmia.

Of the exact relation of these symptoms to the anatomical changes to be immediately described, we do not yet know enough to make definite statements. Olshausen, who first described endometritis fungosa, — a state in which the changes are interstitial, — drew attention to hæmorrhage as the prominent symptom in these latter cases. Wyder also, who has studied the mucous membrane changes found with fibroid tumours, maintains that bleeding occurs in interstitial, but not in glandular endometritis. On the other hand, Veit holds that bleeding may occur with either variety. Whatever be the reason of the hæmorrhage, this is the symptom which most immediately affects the patient's health and calls for prompt treatment.

Pain at the menstrual period is sometimes present, although it is less frequent in endometritis than in inflammation of the uterine append-

ages. It is, of course, characteristic of the exfoliative form. The weak back and other pains will be considered under chronic metritis.

The reproductive function is liable to be affected, although it is surprising how many patients show all the symptoms of endometritis in the intervals between conception. Sterility is occasionally found, but it is difficult to say whether it be not due to associated inflammation of the uterine appendages, as undoubtedly is the case in gonorrhœal infection. Definite information as to the effect of uterine secretions on the vitality of the spermatozoa is wanted. Cases in which conception after a period of sterility follows shortly on curetting, point to the fact that the diseased mucosa in some way prevents conception. Abortion is undoubtedly often due to the morbid condition of the mucous membrane, which leads to hæmorrhages into it, and to bad implantation or death of the ovum.

**Pathology in Relation to Physical Signs.**—Pathology has here rendered service by explaining the conditions found by the sound and curette, the two instruments usually employed in the recognition of endometritis.

The only changes in the uterus are the increase in the size of its cavity, and the swollen and soft condition of the mucous membrane. The latter, moreover, is sometimes thrown into rough projections, and is also so congested that it bleeds easily. All of these features are recognisable by careful use of the sound. In fact, it is for the exploration of the mucosa rather than for determining the position of the uterus, that we find the sound of service; it shows that the cavity of the uterus is always enlarged in cases of endometritis. Rough granulations can be detected by holding the handle delicately; and even the peculiar soft character of the thickened membrane may be thus recognised. If bleeding occurs after its use, congestion of the mucosa exists. It is also said that its introduction is accompanied with pain, and that areas painful to touch can be made out over the fundus (Routh), or in other parts of the uterus (Veit). It is extremely difficult, however, to exclude peritonitic or cellulitic conditions which would also cause pain from the movement given to the uterus as the sound is introduced.

The hypertrophied mucosa can be easily scraped away by the curette, and its microscopic examination by the pathologist has done much to clear up our conception of endometritis, although much has yet to be learned. Cornil, de Sinéty, Heinricius, Küstner, Olshausen, Ruge, and Wyder have all made important contributions on the pathology of the changes of the endometrium in endometritis. Olshansen describes changes in what he calls endometritis fungosa, of which the leading symptom is hæmorrhage. He found the mucosa hypertrophied to three or four times its normal thickness, and elevated throughout in a cushion-like swelling, or in discrete spongy masses. The change stops at the os internum, and does not affect the cervix. The portions removed by the curette show, on microscopic examination, great "hypertrophy of the mucosa, with increase of all its elements, moderate dilatation of the



uterine glands, enlargement of the blood-vessels, and marked cellular infiltration of the connective tissue." The glands are not enlarged so as to produce cystic dilatations.

De Sinéty describes three forms of vegetations removed by the curette. In one the tissue consists mostly of dilated blood-vessels; in another of dilated hypertrophied glands; in a third of embryonic tissue, with but few blood-vessels and only traces of glands. These three forms of granulations he associates with the three kinds of discharge — sanguineous, leucorrhœal, and muco-purulent.

Ruge (29) describes three forms — "the glandular, the interstitial, and the mixed." In the glandular a section shows that the glands, instead of running more or less straight downwards, are cut across in all directions. Their appearance on section varies as the glands have changed their direction, or their epithelium has been altered, star-like and saw-like figures being produced. Sometimes they are dilated into cysts. In the interstitial form the stroma is filled with small round cells, and the vessels are dilated and tortuous; but the glands are not affected. The mixed form is a combination of the other two. The glandular occurs in more advanced life; the interstitial at all periods.

Wyder (44) has studied the changes in the mucous membrane in endometritis accompanying fibroid tumours. He describes Ruge's glandular form as principally accompanying subserous fibroids, and not having hæmorrhage as a symptom. In the interstitial variety, in which hæmorrhage is prominent, the glands are constricted at various points and transformed into cysts; or they are compressed and atrophied. As the result of this the glands are few in number. The interglandular tissue is marked by the abundance of its vessels: it appears in parts as a tissue rich in spindle cells with processes which give it a striated appearance: in other parts it is transformed into a fibrous tissue with few cells. The constricted glands may appear as clear, transparent vesicles, projecting above the surface of the membrane. The cicatrisation of the connective tissue compresses the vessels and leads to hæmorrhage. The process may go on till all the glands have disappeared, and the mucous coat is represented by a homogeneous connective tissue, wavy in outline, which may be covered by a layer of epithelium. When the dilated cystic glands form distinct projections on the surface we have a polypoidal glandular endometritis, which passes insensibly into mucous polypi.

Cornil in his lectures on metritis gives a very complete account of the appearance of the mucous membrane. Its surface is fungoid instead of smooth, and shows villous projections and cysts the size of a pin-head. On section it is 2 to 10 mm. thick — instead of 1 mm. as in the normal condition. The glands are more tortuous; and, what is unlike a non-malignant condition, have grown beyond the usual limit into the muscular wall. The glandular cells, though chronically inflamed, retain their cilia. The layer of flat cells separating them from the interglandular tissue is also undisturbed, which is of importance in diagnosing it from epithelial cancer. That it is a true inflammatory change is seen

from the excess of mucus, the multiplication of epithelium, and the migration of leucocytes. Mucous plugs may be seen, recalling the hyaline casts of albuminuria. Karyo-kinesis can often be observed in the gland cells. Lymphoid cells are found in the gland cavities which have escaped from the capillaries and passed through the gland cells. The interglandular tissue shows dilatation of its vessels and infiltration with wandering lymphoid cells, while the closely packed ovoid cells, of which it is normally composed, swell up and become spherical.

Heinricius has also described specimens taken from cases of endometritis fungosa. He finds the stroma between the glands to consist of a basis of stellate corpuscles, with anastomosing processes, upon and between which lie two varieties of cells—some large, oval, and faintly stained; others small, round, and deeply stained. The former are the nuclei of an endothelium, the latter are lymph corpuscles. His description of the interstitial tissue makes it consist, then, chiefly of lymph sinuses. As the result of the inflammation, the lymph corpuscles and those of the endothelium proliferate and produce an appearance which resembles a small-celled infiltration, as the basis of the network is obscured by the cells. Thus he differs from other observers in regarding the small cells as occupying lymph spaces.

**Relation of Micro-organisms to Endometritis.**—We have already referred to this matter in speaking of the etiology of uterine inflammation; but it is especially in connection with the pathology of the endometrium that the subject comes up for consideration. While attention is being directed more and more to the part played by micro-organisms in inflammation of the uterus, and too much stress cannot be laid on the germ-theory in so far as it leads to rigorous antisepsis in practice, the question is naturally asked, What direct proof is there of the part played by micro-organisms in endometritis? It can only be answered from observations made directly on the endometrium.

As an illustration of the importance attached to micro-organisms, we may take the most recent classification of the varieties of endometritis given by Winckel, who arranges them in two groups, as they are due to micro-organisms or not. In the latter group he places—i. *Simple catarrh* due to disturbance of circulation, as in chlorosis, uterine displacements, faults in dress, mode of life, etc.: ii. *Hæmorrhagic endometritis*, as in acute and infectious diseases: iii. *Decidual endometritis* after abortion; and iv. *Exfoliative endometritis*. In the former group he places—v. *Gonorrhœal endometritis*: vi. *Tubercular endometritis*: vii. *Puerperal septic endometritis*, usually due to the streptococcus longus, more rarely to a staphylococcus or to the bacterium coli commune: viii. *Saprophytic endometritis*, due to combination of cocci and bacilli, of which the *senile purulent endometritis* is probably one form: ix. *The so-called diphtheritic endometritis* which is due to streptococci: x. *Syphilitic endometritis*—the cervical mucous membrane exposed by laceration being a favourable nidus, but infection of the decidua the more important cause: xi. *Endometritis due to fungi*, the yeast plant having been cultivated from the

secretion; and xii. *Endometritis due to amœbæ* — protoplasmic bodies with nuclei and vacuoles being present in the dilated uterine glands, and causing proliferation of epithelium.

Such a classification suggests that micro-organisms are very important factors in the changes. At the same meeting, however, of the German Gynæcological Association, Bumm gave the results of the direct examination of the secretions from forty-five cases of endometritis in the living subject; and he concludes that the affection of the mucous membrane is not kept up by micro-organisms, and that their presence is accidental, and varies with the character of the secretions. He adds, however, that the supposition that chronic endometritis has nothing to do with micro-organisms is not incompatible with the fact that it may be the result of a septic or gonorrhœal infection. So also Gottschalk and Immerwahr, after examining sixty cases of all forms of endometritis, found micro-organisms in the secretions of only one-half of them; and to these they could not attribute a pathogenetic importance, although catarrhal inflammation might be attributed to their agency.

The mucous membrane has also been examined in portions of the uterus removed at operations; and I have already referred to Winter's results, which, however, were not made specially on cases of endometritis. Menge has examined the mucous membrane from seventy-three specimens, including all forms of endometritis, and concludes that neither in the secretion nor in the mucous membrane are micro-organisms present, with the exception of the gonococcus and the bacillus tuberculosis. Further observations upon this subject must be waited for; but for the present we may assume that micro-organisms play a subordinate part in chronic endometritis.

The observations of Pfannenstiel, Döderlein, Gönner, and others on the lochia in the puerperium show the importance of the streptococcus in puerperal sepsis; but this subject belongs to obstetrics rather than to gynæcology.

**The diagnosis** of endometritis before the days of the curette was often uncertain. Hæmorrhage may be due simply to congestion, without permanent changes in the mucous membrane; and some enlargement of the uterus often persists after delivery. Unless the uterus be curetted, and the morbid condition of the endometrium demonstrated, our treatment is still often empirical. We may satisfy ourselves that there is no cause outside the uterus to account for the hæmorrhage or leucorrhœa, and, finding the uterus enlarged, we may assume that endometritis is present. Where it can be traced back distinctly to abortion, diagnosis is more certain.

Of the use of the curette for diagnosis the following illustrations will serve: — Figs. 48 and 49 are sections of scrapings taken from a case of interstitial endometritis — the endometritis fungosa of Olshausen. The patient was a multipara in whom profuse menorrhagia dated from her last confinement. She was curetted on two occasions, as the hæmorrhage recurred after the first curetting. Since the last curetting her menstrual



periods have been normal for some time. The sections show small-celled infiltration in the interglandular tissue, but no hyperplasia of the glands.

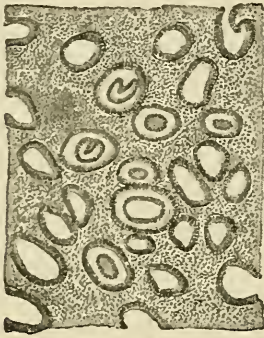

FIG. 48.

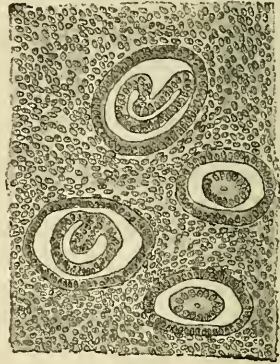

FIG. 49.

Section of tissue removed by curette from a case of interstitial endometritis. Fig. 48 shows the glands and interglandular tissue under a low power; Fig. 49, the same under a high power, to show the small-celled infiltration.

The section given in Fig. 50 was taken from another case in which the endometritis was of the glandular type. The patient, a nullipara, has for five years suffered from considerable hæmorrhages, and has been curetted on different occasions during this period without the benefit seen in the former case. The portions removed by the curette on the last occasion showed marked hyperplasia of the glands, with proliferation of the glandular epithelium, as is well



FIG. 50. — Section of the glands from a case of glandular endometritis. The epithelium is undergoing multiplication. This may pass into a malignant affection.

seen in the portions of the glands shown in Fig. 50. Though the uterus is enlarged there is no infiltration round it; but from the proliferation of epithelium the case may in the end prove to be one of commencing cancer of the endometrium; meanwhile, therefore, the prognosis must be guarded.

The curette has thus come to be of great value in the recognition of endometritis, and of the various changes present in the mucous membrane.

Its use, however, is primarily for treatment, except where commencing malignant disease is suspected; and even here, where as a diagnostic means it might be of most value, it often fails us. The portions of tissue removed are too small to enable us to form a definite conclusion as to the presence or absence of malignant disease. In some cases the malignant cells may be too characteristic for doubt; but



in the majority of cases in which I have used the curette for this purpose, the appearance of the tissue, if "suspicious," has not amounted to a demonstration. This subject, however, belongs to the diagnosis of commencing malignant disease, which is treated elsewhere.

**Treatment.**—The constitutional treatment of endometritis will be discussed under chronic metritis. The local treatment consists in applications made to the uterine mucous membrane, with or without previous curetting. Before having recourse to local applications we should be satisfied of the necessity for them. As in the case of cervical catarrh, local treatment has received undue attention. Vaginal injections, ergotine, and other uterine hæmostatics should always have a fair trial in the first instance.

Applications are made in the solid or liquid form; the latter, either by means of injection or on a sound dressed with cotton wadding. The technique of intra-uterine medication is fully described in the chapter on "Gynæcological Therapeutics." Here we have to consider it only as applied specially to endometritis. With regard to the methods mentioned, I may say that I believe only in the latter; the introduction of the caustic in solid form, so as to melt inside the uterus, is too indefinite in its action. The use of intra-uterine injections has not found favour in British gynæcology owing to the dangers connected with them. I do not, of course, refer to the washing out of the uterus with Fritsch's catheter as part of the operation of curetting, but to the injection of caustics by special syringes, such, for example, as Braun's. Lantos' syringe, in which the point is wrapped in cotton wadding, into which the fluid exudes through holes at the side, is a safe instrument; but it does not possess any decided advantage over a dressed sound. I prefer to make applications with the ordinary sound dressed with cotton wadding; the only objection to it being that the fluid is liable to be squeezed out of the wadding as it is carried through the os. This difficulty can be got over by using a thin film of wadding, by making more than one application, and by preliminary dilatation of a narrow cervix. It is always well to use a dry sound first in order to swab away the mucus, so as to allow the medicament to act. The applications I prefer are iodine, iodised phenol (consisting of 40 grains iodine in one ounce of carbolic acid), and pure carbolic acid prepared by liquefying the crystals. This mode of intra-uterine application has been recommended by Dr. Playfair, who has devised a special probe for it.

Dr. Atthill advocates the use of strong nitric acid, and the preliminary dilatation of the cervix so as to allow of its free application. He uses an intra-uterine speculum of vulcanite to prevent the acid from acting on the cervical canal. Dr. Barnes has devised an ointment-positor for introducing ointments or fluids. He applies the iodide of mercury ointment by this means, or tincture of iodine on a sponge. Mundé uses a 20 per cent solution of chloride of zinc in the manner described above; he recommends also pencils containing 5 grs. of powdered alum and of iodoform, which are left to melt in the uterus.

The best results from intra-uterine medication are obtained when it is applied after previous curetting. It is difficult to define the limits of this operation, but it is perfectly safe, and I have never seen any bad results after it. For this very reason it is liable to be abused, and to be performed in cases where it is not called for. The fact that the uterine mucosa can be so easily removed, and is so rapidly regenerated, is no argument for its removal; and the notion of a substitution of new mucosa free from germs, under aseptic conditions maintained for several weeks by the use of intra-uterine injections, is ingenious but open to doubt.

I would limit the operation of curetting to cases in which there is a clear history of recent abortion, in which there is considerable menorrhagia which has not yielded to ergotine, or in which the sound shows the cavity to be distinctly enlarged and roughened with vegetations. It is not called for in cases of catarrhal endometritis, and of course should not be performed when there is acute or subacute inflammation of the uterine adnexa. Curetting for the endometritis of fibroids, and for the diagnosis of malignant disease, does not belong to the subject we are considering. The mode of performing the operation is described elsewhere. After it is done the uterus is to be washed out with a weak antiseptic, and the other applications then made as mentioned above. Where distinct portions of tissue are removed, they should be preserved for microscopic examination.

Electricity has also been used to check the hæmorrhage in endometritis. As it acts simply by cauterisation of the uterine cavity it does not present any advantages over curetting. It is of service, however, in the endometritis of fibroid tumours, where, in certain cases, it has an effect also on the growth of the tumour.

C. CHRONIC METRITIS. — As in the case of endometritis, I do not consider acute metritis deserving of separate consideration; it appears in most treatises by reason only of the artificial division of affections generally into acute and chronic. The description of its pathology and treatment is taken from cases of puerperal inflammation which do not concern us here. We have good authority for discarding it as a separate affection, when Klob states that he has not met with a single case; Rokitansky, that the uterine tissue is scarcely ever affected primarily; Schroeder, that it is extremely rare; while Thomas regards it as but a complication of endometritis. Sir William Priestley's description of it, in his admirable article in Reynolds' *System of Medicine*, is taken from puerperal sepsis; and in the non-pregnant condition he describes it as occurring chiefly after operations. The use of antiseptics in vaginal operations during the last twenty years, since his article was written, has lessened the frequency of such cases. In the American *System of Gynecology* Palmer says that pure and uncomplicated metritis rarely if ever occurs.

Acute metritis does occur as an exacerbation of the chronic condition, especially in connection with the congestion at the menstrual period, yet

here the chronic affection is more important. We may note also, in passing, the great rarity of suppuration in the uterine wall; most of the cases thus described were abscesses in the cellular tissue beside the uterus.

With regard to the frequency of chronic metritis there is a difference of opinion; but it is largely a question of terms. In the present state of our knowledge we are disposed to relegate to chronic metritis all cases of chronic uterine inflammation which do not come distinctly under the category of chronic cervical catarrh, or chronic endometritis. In doing this we make chronic metritis one of the most important of the inflammatory conditions of the uterus. It may be argued that our ignorance of its pathology, and the difficulty of exactness in its diagnosis, are not a sufficient reason for making it include a large group of cases of chronic invalidism which cannot be classified under the better known affections. For the present, however, this seems the best course for us to take. Under chronic metritis we include those cases which Sir James Simpson described under subinvolution (20), a term which, however aptly, only describes the conditions under which chronic metritis most frequently arises.

**Clinical History and Symptoms.**—No better description could be given of the general features of cases of this class than that of Bennet; although he made the inflammatory condition of the cervix, rather than the accompanying condition of the body of the uterus, the important factor. “To this class belong a large proportion of the population of sofa, bath-chair, nervous, debilitated, dyspeptic females, who wander from one medical man to another, and who crowd our watering-places in summer; most of them are suffering from chronic uterine inflammatory disease unrecognised and untreated, and most of them would, if their disease were only discovered and cured, become amenable to the resources of our art, and eventually recover their health, spirits, and powers of locomotion. It is a singular and instructive fact that amongst the male part of the community there is no similar invalid population, always ill, unable to walk or ride, constantly requiring medical advice, and yet living on from year to year, neither their friends nor themselves knowing what is amiss with them, beyond the evident weakness, dyspepsia, etc.” (2).

The symptoms, also, which Gooch ascribes to the irritable uterus we now attribute to chronic metritis. “To embody them in one view, let the reader fancy to himself a young or middle-aged woman, somewhat reduced in flesh and health, almost living on her sofa for months, or even years, from a constant pain in the uterus, which renders her unable to sit up or take exercise; the uterus, on examination, is unchanged in structure, but exquisitely tender; even in the recumbent posture, always in pain, but subject to great aggravations more or less frequent.” He thus describes exacerbations which are characteristic:—“No disease, however, is so liable to relapse. The patient, feeling easy, finding herself feeble, and supposing that air and exercise are necessary to the recovery of her health, rises and goes about again, and after a short

interval of caution, throws aside her fears, engages in walks, rides, and gaiety, or takes a journey to the sea for the recovery of her health. This conduct commonly occasions a complete relapse, and the patient and her attendant are again involved in the former suffering, apprehensions, and difficulties" (13).

It may be said that some of the cases described by Gooch were cases of affections of the Fallopian tubes, which were not recognised at the time at which he wrote. The line of treatment, however, adopted and the improvement under it shows that we are justified in considering them as cases of chronic metritis. Gooch's reason for not calling the condition a chronic inflammation — namely, that the latter is a disorganising process, while the irritable uterus shows no alteration in structure — proves, on the contrary, that his cases were just what we would now describe as chronic metritis, the results of which tend to be permanent.

The most constant symptom is pain in the lower part of the abdomen and in the loins. Sometimes it is spoken of as fulness or weight in the pelvis, or bearing down. In one word, as Pozzi puts it, the patient knows that she has a uterus. The pain is worst when she is going about, and relieved when she lies down. In this respect it differs from the pain of cancer, which is independent of exertion, and is often described as worse when she is resting at night; probably because there is less to distract her attention from it. Whatever increases abdominal pressure and tends to move the sensitive uterus produces pain. Well-to-do patients, who can take relief by lying on the sofa, gradually come to spend most of their time there.

The fact that the pain is aggravated by movement, and relieved by rest, raises the question whether the cause of it be not sensitiveness in the attachments of the uterus, rather than in the organ itself; whether it be not an associated parametritis or perimetritis? In many cases, however, we cannot find evidence of these affections. If I were to draw a fine distinction I should say, that when pain is aggravated by movement of the uterus — as may be demonstrated on bimanual examination, or the use of the sound — rather than by simple pressure in the iliac regions, the lesion is chronic metritis, not perimetritis. We cannot always be sure that painful cicatrization in the broad or utero-sacral ligaments is absent. The pain is often more marked in the left iliac region, which may indicate cicatrization in the left broad ligament; as most cases of chronic metritis date from the puerperal condition, in which left-sided cellulitis is more frequent because of the greater frequency of left-sided lacerations of the cervix. Pozzi ascribes this pain to inflammation of the left Fallopian tube, though he can give no reason why the left tube should be affected rather than the right. The pain, moreover, is increased by the congestion of the menstrual period, an increase which is ascribed to the flushing of the painful uterus with blood. Sometimes, however, patients are relieved by the menstrual flow, as by a local depletion.

Neuralgic pains are frequent, though it is difficult to say whether



these are due to a source of irritation in the uterus, or to the general "run-down" condition of the system. The disturbances of digestion may more justly be regarded as reflex neuroses — such as the gastric disturbances of pregnancy, which depend upon the close relation between the uterus and the digestive system. The constipation, which is a constant complaint, results probably from the want of exercise; but sometimes it is due to shrinking from the pain of defæcation. In the acute exacerbations, indeed, there may be diarrhœa with tenesmus, due to extension of inflammation to the rectum; as there may be frequent and painful micturition from the extension of inflammation to the bladder.

Disturbances of menstruation are often given as symptoms of chronic metritis. Painful menstruation is certainly one of them, and is accounted for by the congestion of a tender uterus. Profuse menstruation should, however, be referred to an accompanying endometritis; though Fritsch thinks the connective-tissue formation in the wall affects the contractile power of the uterus, which he considers one of the factors which regulate the amount of the menstrual loss. This distinction is not a refinement, but bears on treatment; for such cases can be treated by curetting, which we do not consider to be applicable to metritis. The possibility of the hæmorrhage being due to an associated salpingitis, which has its own appropriate treatment, should also be borne in mind.

The disturbances of the reproductive function (sterility and abortion) are also to be accounted for by the accompanying endometritis.

The general effect on the patient's nervous system is perhaps the most important of all the consequences of this malady, and shows itself in asthenia and hysteria. It is extremely difficult to say how far these elements enter into individual cases, but an accurate appreciation of the proportion between the general and the local factors in these very complex cases is of the first importance when treatment has to be considered. By asthenia we mean the real loss of energy, which can only be made up by such a line of treatment as the Weir Mitchell. [See the section on "The Nervous System in Relation to Gynæcology."] Hysteria, of which the treatment is rather a mental and moral régime, is also an important element in the malady. It is only by taking into account the condition of the central nervous system that we can explain the great variability in the amount and seat of the pain in chronic metritis, the sudden improvements and relapses, and those cures in which the result bears no proportion to the means employed.

**Pathology in Relation to Physical Signs.** — Still less is known of the pathological changes in chronic metritis than in endometritis or cervical catarrh. We have seen that the accessibility of the cervix to microscopic examination in the living subject has, during the last twenty years, given precision to our knowledge of its pathology, and that the curette is performing a like service for the endometrium in enabling us to study its pathological changes during life. An opportunity, however, for examining the condition of the wall is only given in the rare cases of extirpation of the uterus.

Seanzoni's classical monograph on chronic metritis deals entirely with the naked-eye characters.

The microscopic changes have been described by De Sinéty, Fritsch, and Cornil, but further observations are needed.

Seanzoni describes two stages,—an early stage in which the uterus is enlarged, hyperæmic, and soft, and a later one in which it is indurated, anæmic, and hard. Clinically it is impossible to distinguish two such stages: sometimes we find a soft uterus, and sometimes a firm one; but no clinical observations have demonstrated that the one condition follows the other in the same patient. Seanzoni's description is the result more



FIG. 51.—Section of the uterine tissue in a case of chronic metritis: *ct*, connective tissue round the blood-vessels, *bv*; *ls*, dilated lymphatic spaces; *mf, l*, muscular fibre cut longitudinally; *mf, t*, muscular fibre cut transversely (De Sinéty).

of logical deduction from what we know of pathological changes in other organs than of direct study of the uterus.

De Sinéty follows Seanzoni in describing two stages. The first is characterised by "the presence in great number of embryonic elements throughout the whole thickness of the muscular wall. These elements are met with specially round the blood-vessels, or form islands of variable dimensions which are more or less apart." In the second stage he describes marked dilatation of the lymphatic spaces, and a localised hyperplasia of the connective tissue round the blood-vessels. Fig. 51 is a section of the uterine tissue from one case which he examined.

Fritsch's observations were made on uteri which, extirpated for cancer, also showed the naked-eye appearances of chronic metritis. He found that the disposition of muscular fibre and connective tissue is less

regular than in the normal uterus, the individual muscular bundles being split up into small irregular ones. The connective tissue is greatly increased in amount, and its bundles show remarkable bulging and undulations in their course. Areas of normal tissue may be found in the same uterus, showing that chronic metritis may occur in patches. The blood-vessels are more numerous and tortuous, and thus in places produce the appearance of a cavernous tissue; their walls are thickened, especially in the middle coat; the contour of the vessel is masked by a connective tissue replacing the muscular elements in the wall, and the lumen of the vessel is often diminished. The lymphatics appear as gaping spaces instead of narrow clefts. The peritoneum is also thickened. Fritsch holds that the multiparous uterus must always be richer in connective tissue than the nulliparous; seeing that where the special tissues are destroyed by inflammation connective tissue takes their place, and that few multiparæ have not had inflammation in the puerperium.

Cornil also describes, in cases of chronic metritis independent of parturition, a new formation of connective tissue between the muscular fibres; in the tissue opaque points are seen, which represent arteries undergoing atheromatous degeneration. Their walls are thickened by elastic tissue. There is no cicatricial contraction of this connective tissue, but a permanent increase in volume.

It is not necessary here to recapitulate the views advanced under the head of pathology in the works of other writers on chronic metritis; these opinions resolve themselves into a discussion of the meaning of chronic inflammation, instead of giving pathological data for determining the features of the changes in the uterus. The observations of De Sinéty, Fritsch, and Cornil go to show that the essential change in chronic metritis is increase of connective tissue in the uterus. It is, therefore, somewhat analogous to that which occurs in fibroid tumour, save that the connective tissue formation is diffused through the uterus instead of being localised in masses.

Thus pathology is the key to the physical signs. The uterus is enlarged throughout: there is no alteration in its form; its consistence may be either firm or yielding. This equable enlargement of the uterus can be made out by careful bimanual examination and confirmed if necessary by the use of the sound.

**Diagnosis.**—The conditions which are most likely to be mistaken for chronic metritis are enlargement of the uterus from commencing pregnancy, small fibroid tumours, and malignant disease.

In the case of early pregnancy, amenorrhœa and other symptoms should put us on our guard. The cervix is softened, although this softening is not so well marked in a multipara where the cervix has been previously indurated by chronic inflammation: the bimanual examination shows the change in the form of the uterus due to growth of the ovum. In chronic metritis there is no alteration in the shape of the uterus, but in pregnancy there is a globular enlargement: the vaginal finger recognises the anterior wall bulging out from the cervix while the abdominal hand



feels the rounding out of the fundus, combined with a softness which prevents us from distinctly defining its outline. Where resistance of the abdominal walls makes the bimanual examination difficult, the finger may be able to recognise through the rectum the bulging and softness of the posterior uterine wall in contrast with the thin and compressible lower uterine segment. Pregnancy can be detected by careful bimanual examination as early as the eighth week. Where there is any doubt, by waiting a few weeks the diagnosis from chronic metritis becomes easy.

Small fibroid tumours closely simulate chronic metritis. The symptoms are the same; and on bimanual examination it is often extremely difficult to distinguish the uneven enlargement of a fibroid from the uniform enlargement of chronic metritis. By passing the sound so as to define the course of the uterine canal and the position of the fundus, and then making a careful bimanual examination with the sound in position, we are able to detect small fibroids of the anterior or posterior wall. Intra-uterine fibrous polypi can only be recognised by dilating the cervix.

While the diagnosis of chronic metritis from small fibroids is often of little moment, the diagnosis from early malignant disease is of great consequence. The age of the patient, the character of the pain, and the nature of the discharge, must all be taken into account. Free bleeding is also more suggestive of malignant disease, especially after the menopause; although I have seen patients with fungous endometritis and chronic metritis lose a considerable amount of blood. In doubtful cases the cervix should be dilated so as to allow the endometrium to be carefully examined with the finger or curette.

**Treatment** rests upon pathology; and the view we take of the nature and etiology of chronic metritis determines our treatment. The pathological facts, so far as we know them, are that the lesion consists in an increased formation of connective tissue in the uterus, and that the most favourable circumstances for its development occur during the puerperium.

Sir James Simpson rendered a great service by calling it "subinvolution," thus drawing attention to the importance of the puerperal state in connection with its etiology. The best treatment is preventive; and the removal of whatsoever interferes with the involution of the uterus, is to be put in the forefront in the treatment of chronic metritis. Attention to the complete emptying of the uterus after delivery, and early removal by curetting of portions retained after abortion, are of the first importance. To stimulate the involution of the uterus by douching during the puerperium, to administer ergot, to order sufficient rest, and to forbid patients to return too soon to their ordinary duties, are measures of preventive treatment which cannot be overrated in importance.

Fortunately patients with chronic metritis are not often sterile; and it is to the proper management of a subsequent puerperium that we must look for the treatment of this condition. The natural cure that then takes place is the only efficient one.

On passing now from preventive treatment to the general treatment of metritis, we shall find that to describe the treatment recommended by



the various writers on this subject would be simply to recapitulate all the resources of gynæcological therapeutics. Thus is revealed the importance of the lesion, inasmuch as all the means at our command have been employed in dealing with it, and with more or less success; yet variety of treatment generally means ignorance of the nature of the disease: as our knowledge grows our treatment is simplified.

The main object of local treatment is to diminish passive congestion of the pelvic organs; and here again the first indication is rest. Continuous rest, however, is bad, for it favours congestion; daily exercise in the open air is as necessary as an hour or two of rest on the sofa in the middle of the day. Tight garments which compress the abdomen should be discarded; on the other hand, where the abdominal muscles are flabby, a well-adjusted abdominal belt often makes the patient more comfortable. Lax abdominal muscles are occasionally associated with a relaxed vagina and a tendency to prolapse: in such cases a ring pessary to support the heavy uterus is useful.

To stimulate the pelvic circulation the hot douche is invaluable. It should be administered freely in the recumbent posture, and, if possible, by a trained nurse. It is of little value unless it is done thoroughly.

Preparations of ergot also lessen uterine congestion. It is in the puerperium that we expect the most permanent benefit from this drug, on account of its action on the muscular fibres of the uterus, promoting their contractions and favouring their involution. Ergot is also useful in other circumstances, especially where there is menorrhagia. The liquor hydrastis canadensis may be used alternately with ergot, although it is not nearly so trustworthy.

The passive congestion can also be relieved by depletion, although this is not used nearly so much now as formerly. The best mode is by scarification of the cervix; but we would limit its use to cases where there is marked cervical hypertrophy. A more practical method is the abstraction of serum from the tissues by glycerine tampons, which have this advantage that they can be applied by a nurse, or even by the patient herself. A 10 per cent solution of ichthyol and glycerine I have found even more serviceable than simple glycerine. A course of systematic douching, combined with ichthyol tampons, in the hands of a trained nurse for several weeks is, in my experience, the most satisfactory local treatment for chronic metritis. Where the parts are too tender for the regular application of ichthyol tampons, ichthyol pessaries are a useful substitute.

Attention to regular evacuation of the bowels is of the greatest consequence not only for lessening pelvic congestion, but also for improving assimilation. The benefit derived from certain mineral waters is probably due largely to their aperient action as well as to the regular mode of life prescribed at the different health resorts.

When exacerbations occur, showing that the affection has become acute for the time, we have recourse to hip-baths or warm fomentations with complete rest, and to morphia suppositories to relieve the pain and check the diarrhœa which are sometimes present. For the irritability

of the bladder the hot vaginal douche and the usual sedatives are useful.

Where cervical catarrh or endometritis are the prominent features, these must be treated in the first instance; and the treatment directed to them will lessen the chronic metritis. While separating these various affections for the purpose of studying them, we must remember the intimate relation that exists between them; so intimate is it, that some writers prefer to consider inflammation of the uterus as one affection varying in its manifestations according to the tissue involved. I do not accept this view, inasmuch as it suggests that there is an entity — inflammation — appearing in one tissue after another. Of the close causal connection, however, between inflammation in one part and another, there is no doubt. Chronic metritis is intimately related both to endometritis and to cervical catarrh, and can sometimes be treated only through these. Thus, after curetting the uterus for endometritis after abortion, or after amputating a hypertrophied cervix, we find an enlarged uterus becoming smaller, and the general condition of the patient undergoing improvement.

Attention to the general health is of great importance. The patient's diet requires careful study, and we must have regard to digestion as well as to appetite. While some patients require feeding up, others call for a restriction of food. A patient may eat well and largely, and yet assimilation may be defective. When this is the case, alcohol is often taken, from the idea that it aids digestion instead of retarding it. Marked improvement in the patient's general condition often follows on the prescription of a dietary of light and easily digested food, with a diminution in the amount of stimulant. Each case must, of course, be studied by itself. No rules can be laid down except that we should not let the condition of the uterus divert attention from the condition of the stomach.

Change of air, change of scene and occupation, are invaluable. It is to their influence as much as to the mineral waters that the benefit from visiting the various spas is due. It would be out of place here to enumerate them, and the subject has become of such importance that special works on the subject must be consulted.

The operative treatment of chronic metritis occupies a very subordinate place. After operations on the cervix it has been noted that an enlarged uterus diminishes in size: this is specially the case after amputation of the cervix. Although this is a very important result of the operation, the value of which I have noted repeatedly, I should hardly describe it as a means of treating chronic metritis, as the operation is only called for where the hypertrophy of the cervix itself is so great as to justify amputation on independent grounds. Of the diminution of the uterus after Emmet's operation I have not been able to satisfy myself, although Emmet and other American operators claim this as one of its beneficial results. Of the igni-puncture of the cervix advocated by Prochownik, I have had no experience.

A. H. FREELAND BARBOUR.

## REFERENCES

1. ATTHILL. "On Endometritis," *Dublin Journal of Medical Science*, Jan. 1873. —
2. BENNET, HENRY. *Practical Treatise on Inflammation, Ulceration, and Induration of the Neck of the Uterus*. London, 1845. — 3. *Ibid.* *A Review of the present State of Uterine Pathology*, p. 11. Lond. 1856. — 4. BRENECKE. "Zur Aetiologie der Endometritis Fungosa," etc., *Archiv f. Gyn.* Bd. xx. S. 455. — 5. BUMM. "Ueber die Aufgaben weiterer Forschungen auf dem Gebiete der puerperalen Wundinfection," *Archiv f. Gyn.* xxxiv. S. 325. — 6. CORNIL. *Leçon sur l'Anatomie pathologique des Métrites*, etc. Paris, 1889. — 7. CZEMPIN. "Ueber die Beziehung der Uterusschleimhaut zu der Erkrankungen der Adnexa," *Zeits. f. Geb. u. Gyn.* Bd. xiii. Hft. 2. — 8. DÜDERLEIN. "Ueber Vorkommen und Bedeutung der Micro-organismen in der Lochien gesunder und kranker Wöchnerinnen," *Centralb. f. Gyn.* 1888, No. 23. — 9. DUNCAN, MATTHEWS. *Diseases of Women*. London, 1886. — 10. FISCHEL. "Ein Beitrag zur Histologie der Erosionen der Portio Vaginalis Uteri," *Archiv f. Gyn.* Bd. xv. S. 76. — 11. FRITSCH. *Die Lageveränderungen und die Entzündungen der Gebärmutter*. Stuttgart, 1885. — 12. GÖNNER. *Ueber Micro-organismen im Secret der weiblichen Genitalien während der Schwangerschaft und bei puerperalen Erkrankungen*, 1887, S. 444. — 13. GOOCH. *On some of the most important Diseases peculiar to Women, etc.*, pp. 156, 157. New Sydenham Society. Lond. 1859. — 14. GOTTSCHALK. *Centralb. f. Gyn.* 1895, No. 27. — 15. HART, D. BERRY. "The Pathological Classification of Diseases of Women, with a Plea for a Revision of Current Views," *Edin. Obstet. Trans.* vol. xix. p. 82. — 16. HEINRICIUS. "Ueber die chronische hyperplasirende Endometritis," *Archiv f. Gyn.* Bd. xxviii. S. 163. — 17. HOFMEIER. "Folgestände des chronischen Cervixkatarrhs und ihre Behandlung," *Zeitsch. f. Geb. u. Gyn.* Bd. iv. S. 331. — 18. IMMERWAHR. *Centralblatt f. Gyn.* 1895, No. 26. — 19. KLOTZ. *Gynäkologische Studien über die pathologischen Veränderungen der Portio Vaginalis Uteri*. Wien, 1879. — 20. KUESTNER. *Beiträge zur Lehre von der Endometritis*. Jena, 1885. — 21. LEE. *Trans. of the Med.-Chir. Soc.* vol. xxxiii. p. 270. — 22. MENGE. *Centralb. f. Gyn.* 1895, S. 714. — 23. OLSHAUSEN. "Ueber chronische hyperplasirende Endometritis des Corpus Uteri," *Archiv f. Gynäk.* Bd. viii. Hft. 1. — 24. PALMER. *The Inflammatory Affections of the Uterus: a System of Gynaecology, by American Authors*. Edited by Matthew D. Mann. Edin. 1887. — 25. PFANNENSTIEL. "Kasnistische Beiträge zur Aetiologie des Puerperalfiebers," *Centralb. f. Gyn.* 1888, S. 617. — 26. PLAYFAIR, W. S. "Intra-uterine Medication," *British Medical Journal*, Dec. 1869, March, 1880; *Lancet*, Jan. and Feb. 1873. — 27. POZZI. *Treatise on Gynaecology, Clinical and Operative*, The New Sydenham Society Translation, 1892. — 28. PRIESTLEY, Sir W. O. *Inflammation of the Uterus, A System of Medicine*, edited by J. Russell Reynolds, M.D. vol. v. London, 1879. — 29. RUGE. "Zur Aetiologie und Anatomie der Endometritis," *Zeits. f. Geb. u. Gyn.* Bd. v. S. 317. — 30. RUGE and VEIT. "Zur Pathologie der Vaginalportion," *Zeits. f. Geb. u. Gyn.* 1878, Bd. ii. S. 415. — 31. SCANZONI. *Die chronische Metritis*. Wien, 1863. — 32. SCHROEDER. *Charité annalen v. Berlin*, 1880, S. 340. — 33. SIMPSON, Sir JAMES. *Diseases of Women*, p. 585. Edin. 1872. — 34. SINCLAIR, WM. JAPP. *On Gonorrhæal Infection in Women*. Lond. 1888. — 35. SINÉTY, DE. *Manuel de Gynécologie*, p. 327. Paris, 1879. — 36. *Ibid.* Pp. 315, 351. — 37. SMITH, TYLER. "Observations on the supposed Frequency of Ulceration of the Os and Cervix Uteri," *Lancet*, vol. i. 1850, p. 474. — 38. SPIEGELBERG. "Die Diagnose des ersten Stadium des Carcinoma Colli Uteri," *Archiv f. Gyn.* iii. S. 233. — 39. THOMAS. *Diseases of Women*. Edited by Paul F. Mundé. London, 1891. — 40. WEST. *On the Pathological Importance of Ulceration of the Os Uteri*, Croonian Lectures. London, 1854. — 41. *Ibid.* *Diseases of Women*. London, 1856. — 42. WINCKEL. "Bericht über die Verhandlungen der sechsten Versammlung der deutschen Gesellschaft für Gynäkologie," *Centralb. f. Gyn.* 1895, No. 26. — 43. WINTER. "Die Micro-organismen im Genitalcanal der gesunden Frau," *Zeitsch. f. Geb. u. Gyn.* Bd. xiv. Hft. 2, S. 443. — 44. WYDER. *Tafeln für den gynäk. Unterricht*. Berlin, 1887. — 45. *Ibid.* "Die Mucosa Uteri, bei Myomen," *Archiv f. Gyn.* xxix. p. 1.

## THE NERVOUS SYSTEM IN RELATION TO GYNÆCOLOGY

IN the study of gynæcology a cardinal factor, which is often underestimated and even altogether overlooked, is the highly sensitive nervous organisation of the female sex. The mobility of the nervous system, especially in the sphere of the emotions, which distinguishes the woman from the man, influences the character and progress of all kinds of disease in women, but more especially diseases of the reproductive organs. This factor calls for very careful consideration.

Up to the time of puberty there is little if any marked difference between the sexes, either in health, in disease, or in any other condition. Conventionally they are separated; but boys and girls will play together, work together, and associate generally in perfect equality; the qualities which distinguish one sex from the other being either latent or seen but obscurely. As soon, however, as the great function of menstruation is established, which is henceforth to influence the woman during the whole period of her sexual life, the entire system undergoes a marked change: the asexual child becomes a woman; her body undergoes characteristic modifications fully described in all works on physiology and obstetrics; and with them are to be observed the not less important changes in character, and in the general development of the nervous system, which distinguish the woman from the girl. It is at this important time that the conduct of the health of the growing girl may influence for good or for evil the whole future of the woman. Judiciously managed, she may be so trained that she will be able to meet successfully the strain on her nervous system during her future life; the duties of a wife and mother, the struggle with domestic anxieties and worries, or the sorrows which are rarely altogether absent from the lot of mankind. Injudiciously managed, as is the case with so many at this important epoch, all those things, which the strong-bodied and healthily minded woman may bear with no permanent bad results, will tell terribly upon her. She will have no stamina, no power of resistance; and she may become the wretched, broken-down invalid so often met with in the present day, especially in those ranks of life in which the evil effects of unbalanced culture, and the bringing up of girls like hothouse plants, are so frequently seen.

This being so, it may be well to preface what has to be said on the influence of the nervous system on gynæcology by a few words on the education and training of girls at and after the establishment of puberty. This is all the more necessary since the higher education of women has taken such enormous strides of late years that it is now regularly recognised, and is almost universal. The "High Schools" for girls are to be met with everywhere, and the still more advanced colleges



of the type of Girton and Newnham are rapidly increasing in number, and are full of students. The old-fashioned girls' boarding-schools, with their perfunctory education and their elegant accomplishments, are driven out of the field; and a movement which at first was scoffed and jeered at has now gained the day.

Let me say at once that, with limitations which are essential because of the difference of sex which cannot be got over, the movement is one which seems to me an enormous gain, and of it I write in no spirit of opposition. This statement is needful, since there is an unfortunate tendency on the part of many mistresses of high schools to listen to the warnings of medical men with incredulity, and to accuse them of narrow-mindedness and opposition, of which, as a matter of fact, the great majority of them are in no way guilty. The recognition of possible evils, and due warning against them, are neither the one nor the other.

The one great fault of those who manage these educational establishments is that they have too often started on the absolutely untenable theory that the sexual factor is of secondary importance; and that there is little if any real distinction between a girl between the ages of 14 and 20, and a boy of the same age.

I know of no large school for girls where the absolute distinction which exists between boys and girls as regards the dominant menstrual function is systematically cared for and attended to. The feeling of all school mistresses seems to be antagonistic to such an admission. The contention is that there is no real difference between an adolescent man and woman; that what is good for one is good for the other; that the apparent differences are due to the evil customs of the past, which have denied to women the ambitions and advantages open to men, and that these will disappear when a happier era is inaugurated. If this be so, how comes it that while every physician of experience sees many cases of *anæmia* and *chlorosis* in girls, accompanied by *amenorrhœa* or *menorrhagia*, headaches, palpitations, emaciation, and all the familiar accompaniments of break-down, an analogous condition in a school-boy is so rare that we may well doubt if it is ever seen at all?

These disorders certainly do not necessarily result from the work. The successes of women in the schools have been so striking and numerous that their capacity for intellectual work cannot be doubted for a moment. On the other hand, the male's work is safeguarded by an amount of physical exertion in the way of sport which serves to keep him in health. It is true that in university colleges and in a few girls' schools attention has been paid to this point of late; but in a perfunctory sort of way at the best. There may be a gymnasium, or some form of games; but while at a boys' school cricket and football are compulsory — to say nothing of the natural disposition of a boy to athletic pursuits — at a girls' school, exercise is optional; and if a pupil tending to ill-health avoids it, little or no attention is paid to the matter. Within the past week as I write, I have been consulted in the cases of two young ladies, aged respectively 14 and 16. One was chlorotic, and her menstruation

had ceased for a year. On taking her time-table at a well-known high school, she had  $7\frac{3}{4}$  hours' work, — an amount not in itself, perhaps, excessive in a healthy girl. From 2.30 to 4 there were no lessons, and, if the weather permitted, she might if she liked take a walk; but it was not insisted upon; and as she was naturally languid and listless, as all such girls are, she rarely did so. There was no other opportunity for exercise at all. The other girl suffered from pronounced menorrhagia, anæmia, and debility. Her time-table was also seven to eight hours, and she "occasionally took a walk." In neither of these cases had the school authorities ever inquired into the state of an all-important bodily function, which in both was very markedly aberrant; yet, considering the paramount importance of such symptoms of impaired health in girls of these ages, it might fairly be held to be part of the duty of those in authority in such schools to make the necessary inquiries, and to modify the course of study or mode of life accordingly.

While it is questionable whether in boys' schools the attention given to exercise and athletics may not be excessive, in girls' schools it is, on the other hand, not nearly sufficient. And yet this is a fault which might be very easily remedied. It would not be difficult to make the games of girls' schools compulsory as they are in public schools for boys; there are many games admirably adapted for women, as, for example, golf, hockey, lawn tennis, rowing where it is feasible, or, it may be, bicycling. Each of these exercises the muscles generally without the spasmodic efforts required in cricket or football, which may be too violent for some girls. The result when such games are freely used must be well known to all who have a knowledge of what a thoroughly healthy English girl may be. No better description of it could be given than that contained in a leading article in the *Speaker*, on what the writer calls "The Lawn Tennis Girl":—

Sensible people have long ago agreed to accept this new type of womanhood as being distinctly admirable. She has made her influence felt everywhere, both in real life and in fiction. In real life we meet her in every country house, in every foreign hotel, and almost in every London square. And wherever we meet her we come upon an excellent example of the healthy, well-developed, and unsentimental girl—the girl who does not think it necessary to devote herself to the study of her own emotions, and who finds in active physical exercise an antidote to the morbid fancies which are too apt to creep into the mind of the idle and self-indulgent (13).

This is an excellent description of a type with which we are all familiar, and, it is needless to say, we all admire. If high-class schools could succeed in turning out girls of this kind in larger numbers than at present, they would do more towards lessening the number of neurotic women the medical profession has to deal with than the medical profession can possibly do by any exercise of its own art.

It is an obvious corollary from what has been said, that it is the bounden duty of mistress, parent, and doctor to insist at once on the

cessation of all severe study when any of the physical signs of illness, such as it is impossible to mistake, have shown themselves,—as, for example, chlorosis, amenorrhœa or menorrhagia, wasting, loss of appetite, and the like. In my judgment it is not work which hurts, but perseverance in work after nature has hung out its danger-signals—work in an unhealthy body, the attempt, in fact, to fight nature. Then, indeed, the careless, prejudiced, and unwise mistress or parent may well find out that the results of “over-pressure,” the very existence of which so many deny, are a stern reality, and may shatter the whole future of the girl.

In the present article we are not called upon so much to consider the subject of the nervous system in general, as its special influence on our work as gynæcologists. Still, the important question naturally suggests itself, Are morbid nervous states, of the type now generally known as neurasthenic, on the increase amongst us? Or is their supposed prevalence due to more careful observation, and the recognition of conditions formerly unobserved, and not referred to their proper source?

To these questions it is not easy to give a satisfactory reply, for no definite statistics exist by which they can be settled. It is pretty certain that morbid functional neuroses are far more common in the cultured and educated classes than in the comparatively uneducated. This accounts for the absence of cases of advanced neurasthenia in our hospital wards and out-patient clinics in England. Such states are indeed almost limited to private practice among the upper classes of society; and they may explain, to a great extent, the comparative neglect of such illnesses, all-important though they be, by our clinical teachers, whose material for instruction is chiefly, if not altogether, supplied by hospital patients. There can be no doubt that culture and education, and their results in increased nerve stimulation, have taken enormous strides within the last fifty years. This has been well illustrated by Max Nordau in his remarkable work on *Degeneration*. “In 1840,” he says, “there were in Europe 3000 kilometres of railway; in 1891 there were 218,000 kilometres. The number of travellers in 1840 in Germany, France, and England amounted to  $2\frac{1}{2}$  millions; in 1891 it was 614 millions. In Germany every inhabitant received in 1840, 8 letters; in 1888, 200 letters. In 1840 the post distributed in France 94 millions of letters, in England 277 millions; in 1881, 595 and 1299 millions respectively. In Germany in 1840, 305 newspapers were published; in 1891, 6800; in France 750 and 5782; and in England (1846) 551 and 2255. All activities, even the simplest, involve an effort of the nervous system and a wearing of tissue. In the last fifty years the population of Europe has not doubled, whereas the sum of its labours has increased tenfold, in parts even fiftyfold. Every civilised man furnishes at the present time from five to twenty-five times as much work as was demanded of him half a century ago.”

It is reasonable to conclude that nervous breakdown and morbid states of the nervous system of all kinds should increase *pari passu* with

the increasing developments of nerve work referred to, and such is probably the case.

It is indeed likely that many illnesses, formerly misunderstood and neglected as being beyond the power of the practitioner to alleviate, are now referred to their proper cause, and correctly diagnosed.

This is the view taken by Professor Allbutt, who contends that neurasthenia is not more frequent than it has been for some generations past, but that it is better understood. Every one will concede the correctness of his contention that the more a nervous system is worked the better it is for its owner, with this reservation, which he fails to insist on, that this must be in a healthy body. As has already been pointed out, it is not work that seems to hurt, but work plus something else, such as physical frailty, worry, anxiety, and the like; and these persisted in in spite of warning. It will probably be generally admitted that the conditions of modern society are such as to make this kind of addition to work of the nervous system increasingly common. It is remarkable, moreover, that this type of disease is far more frequently met with in what may be called the centres of nervous energy and strain. I have constantly observed that such cases are enormously more frequent in such centres of active work as Glasgow, Liverpool, Leeds, and Manchester, than in the comparatively idle and fashionable members of West End London society. This is borne out by the returns of the Registrar-General, which show that in the census year the death-rate from nervous diseases in London was only about 22 per 10,000 persons living, while it runs up to 28·6 for Lancashire, 29·5 for the West Riding, 31·8 in Leeds, 32·8 in Blackburn, 33·7 in Preston, and 34·5 in Sheffield.

The reason of this is probably complex. Partly it may be due to heredity, since patients from such places are generally the daughters of busy, active, pushing business men, who have been the architects of their own fortunes; partly it may be due to the fact that such patients live in an atmosphere of strain and bustle, and in which vicissitudes of fortune are far from uncommon.

Similarly these types of diseases are said to be much more frequent in such new and very "go ahead" countries as Australia and America; so much so, that neurasthenia has been by some described as the "American disease." It is often said that national peculiarities have a great deal to do with determining the liability to these illnesses. Thus it is remarkable how comparatively rare in this country are the aggravated types of hysteroneurosis (such as are apparently common enough in France, if we may judge by the writings of Charcot), accompanied by trance, contractures, and the like; and this may justly be attributed to the greater general excitability of French women. This disease is, however, very unlike general neurasthenia, which is certainly something altogether different from the so-called hysterical state, and is by no means necessarily — or even most frequently in my experience — met with in women of very excitable temperament; or at any rate not in idle and fanciful women; it is seen rather in women of more than average intellect, who have exhausted



their nervous systems by undue strain or anxiety, and who have struggled with the early symptoms of "nerve-tire," and refused to take note of the signs of impending mischief.

Having said so much as to prevention, which is so much better than cure, as regards the healthy action of the nervous system in women, let us now proceed to consider it in its morbid action as we observe it in the study of gynæcology.

Functional neuroses arise easily in women; they may assume tremendous proportions, and their growth may be readily fostered and encouraged until, like some noxious weed, they choke all health of body and mind. But it is not easy, when once they are fully established, to trace them to their source; and unless we get at all the "*fontes et origines mali*," which may differ much in different cases, any rational system of cure is practically impossible.

Broadly speaking, we may say that there are **two classes of cases** with which we have chiefly to deal:

1. We may have some definite uterine or pelvic lesion, which may be the starting-point of secondary reflex neurotic complications, and in these cases attention is mainly to be directed to the cure of the originating local complaint.

2. We may have a condition in which some local lesion, in itself of minor importance, may be found, or has been found. This, indeed, may even be only a secondary result of the general neurotic condition which is the dominant factor in the patient's health; and the treatment of it may not only be inadmissible but, injudiciously carried out, may be intensely prejudicial, and very gravely increase the general ill health from which the patient suffers. As a further development of this, we may often meet with cases in which some definite existing local lesion very probably started the illness, but which has in time become so over-shadowed by its own secondary consequences that the judicious practitioner will minimise any treatment of it as much as possible.

The importance of the first class of case is certainly very great, and deserves the most careful study on the part of the gynæcologist.

There can be little doubt that **secondary functional disturbance of remote organs very commonly originates in some definite morbid local condition of the uterus or ovaries**, the irritation being conducted along the ganglionic and spinal nervous system. Every practitioner is familiar with the influence of the reproductive system in producing such a disturbance of distant organs as the neuroses of pregnancy; not only the commonly observed morning sickness, which may run into uncontrollable and even fatal vomiting, but other neuroses of an obviously similar type, but less commonly recognised, as, for example, excessive salivation, cardiac disturbances, the so-called "lypothymia," or partial trance, and such well-marked mental conditions as extreme depression of spirits or insanity.

It is familiar to the obstetrician that in many of these cases all general treatment fails, while local treatment, such as the application of carbolic

acid or iodine to an inflamed or abraded cervix, or the lifting of a retroverted gravid uterus out of the pelvic cavity, may give relief at once.

That similar local irritations in the non-pregnant woman may set up marked distal disturbances is a fact which the general physician is very apt to overlook; hence many a sufferer has been uselessly treated by incessant drugging, whose symptoms would at once have disappeared if the coexisting uterine or ovarian source of irritation had been detected and relieved.

Of course it is imperative that care should be taken not to overlook any unsuspected source of illness of this kind. Should some obvious lesion be found — such, for example, as a hyperplastic uterus, a badly lacerated and everted cervix, profuse uterine or cervical catarrh, swollen and tender ovaries and tubes, well-marked flexion or version — then no judicious practitioner would fail to remedy it by appropriate treatment, the details of which are fully considered in the several articles of this work. Above all things, however, it is essential that there should be no mistake about this — that the lesion we are treating should be real, decided, and unmistakable, and that the local treatment should be judicious and minimised as much as possible. We shall presently have to dwell more particularly on the evil effects which in nervous and emotional women are apt to follow injudicious and over-frequently repeated local treatment.

There are two possible errors which may be made in connection with this matter. One is that a distinct local lesion, which is the originating cause of a secondary nervous disturbance, may be overlooked and not treated at all; and thus the nervous condition may be maintained. The other is that **exaggerated importance may be attached to some local lesion** which is detected; that the error of diagnosis may be accompanied by an error of judgment, and that much needless local treatment of what may be called the “tinkering” kind is adopted: thus the coexisting neurosis is aggravated. Both mistakes are serious ones; but I am constrained to say — and the more I see of neurotic women the more convinced I am — that the latter is much the more serious and common of the two. Nothing can be more deplorably bad for a nervous, emotional woman, whose general health is at a low ebb, than to have her attention constantly directed to her reproductive organs by vaginal examinations repeated two or three times a week, pessaries constantly introduced for “a slight displacement,” the cervix frequently cauterised, or the endometrium curetted, and the like; and yet these are things one incessantly sees in cases in which, on examination, no definite reason for such interference is found to exist. No doubt it is generally done in good faith; but the results are often disastrous, and I feel it to be my duty to insist very emphatically on the necessity of carefulness in this direction.

These remarks apply more especially to the second class of case referred to, in which we are justified in concluding that the local affection was either of secondary importance from the beginning, or has become so

in consequence of long-existing bad bodily health and the supervention of a morbid neurotic condition.

It is scarcely consistent with the limits of this paper, which specially contemplates the discussion of such neurotic complications as come under our observations as gynæcologists, to enter into a detailed description of the conditions known of late years as "Neurasthenic"; these will naturally be more fully discussed under this head. Indeed they are protean in character, and in no two cases are the symptoms identical. This one might expect, as the main element in the morbid state we have to deal with is the unhealthy action of a subtle and invisible function, quite beyond those ready means of examination which we can apply to the heart, lungs, or digestive organs, but which influences any or all of them nevertheless. Hence the risk of mistaking disturbed action of various parts and viscera—as, for example, insomnia, headache, spine-ache, palpitations, nausea, loss of appetite, and a host of other conditions—for diseased states of parts which, in themselves, may well be substantially healthy. Exactly the same error may be, and often is made with reference to apparent disorders of the reproductive system; in these we may find cessation or disorder of menstruation, some increase of discharges or secretions, uterine and ovarian pains and aches of various kinds; but yet no structural lesion of any real moment.

One permanent characteristic, however, is to be found in all cases of this sort which merits the most careful attention, and is constantly overlooked; this is **defective general nutrition**, involving as this, of course, does, badly nourished and therefore imperfectly acting nerve centres, and, as a consequence, defective action of all the viscera supplied and controlled by them.

This defect is, indeed, the keynote to the treatment of a large number of cases of ill health in women, which are often associated with morbid conditions referable to the reproductive organs, but are quite incurable until the general nutrition and health of the patient is placed on a satisfactory basis. A woman has some headache, or other disturbance, and for this she is perhaps advised to rest. Gradually all healthy habits of body are dropped, one by one, until she hardly leaves her sofa, and takes no kind of exercise. As a consequence the appetite fails, less and less food is taken, and progressive emaciation and great general debility supervene, with all the well-known attendant symptoms of chronic invalidism. Or it may be that another type of defective nutrition shows itself, attended with a deposit of unwholesome flabby fat in the subcutaneous tissues; and the patient, while weak, a poor eater, invalided and sofa-ridden, becomes overburdened with unwholesome and useless fat.

These are precisely the conditions in which emotional disturbances of the worst kind appear. Some injudicious relative or friend is rarely lacking in such a case who adds fuel to the fire by constant unwise nursing and unduly sympathetic attendance. In many instances, it is to be feared, the medical man, at his wits' end to do something, makes matters worse by constant visiting; endless talks as to symptoms: and

incessant prescriptions in which the inevitable bromide, and similar harmful drugs, play a prominent part. It is a happy thing for his patient if amongst them narcotics have not found a place; too often chloral, sulphonal, morphia, and the like have been resorted to, until at last the patient may have insensibly sunk into the deplorable habits of a chloral or morphia taker.

This description, of course, refers to the case of the confirmed neurasthenic invalid so often to be seen. But short of so advanced a type of neurotic illness the gynæcologist cannot fail to call to mind numberless women on the down grade, who were drifting into some such state of chronic ill health, the physical path to which is defective nutrition, and who could almost certainly have been arrested in their downward course if the real cause of their illness had been thoroughly appreciated and acted upon.

It follows from what has been said that, in the large majority of neurotic cases coming under our observation in gynæcologic practice, the main object of treatment should be to improve the general nutrition, and so to aim at better general health. How is this difficult task to be accomplished? It is far easier to point out how it is not to be done; and, unluckily, the path which certainly does not lead to success is the one most generally followed. It is certainly useless in a confirmed case of this kind to attempt to cure the patient by way of the chemist's shop. Gallons of physic have generally been swallowed by her already, and the judicious practitioner will not add to the number of useless or possibly harmful prescriptions which a patient of this kind invariably has to show. If the case be a comparatively mild one, a little common sense, a quality not too generally found in the regulation of the treatment of neurotics, may be all that is required. An endeavour to ascertain and remove any more immediate causes, if such exist, whether physical or mental; the insistence on a proper amount and quality of easily assimilated food; the removal from unwholesome domestic surroundings, which may be brought about by change of air and scene,—these, or similar prescriptions, which vary in accordance with the peculiarities of each individual case, may suffice to restore the patient to health, and give back to her the efficient control of her nervous system which she had lost.

In the more severe cases, in which the symptoms of neurasthenia are well marked and of long standing, something more definite is required to give the patient a fair chance of recovery. Here that combined attack on defective nutrition known of late years as the "**rest cure**," or "**The Weir Mitchell**" treatment (so called after the well-known American physician to whom we owe its introduction as a systematic method of treatment) may, in properly selected cases, prove an invaluable resource. Suffice it to say that, properly and judiciously carried out in well-selected cases, its results are most striking and satisfactory, and hundreds of women are now going about well and strong who but for this would still be the wretched invalids they formerly were.

As the present writer was mainly instrumental in introducing this



method of treatment into Europe, he may perhaps be regarded as unduly prejudiced in its favour. He ventures, therefore, to quote the estimate formed of it by the late lamented American gynæcologist, Dr. Goodell, which was probably one of the very last things he ever wrote:—

One of the grandest discoveries in the treatment of the nervous phase of women's diseases is the rest cure, for which we owe a large debt of gratitude to Weir Mitchell. Formerly there were in every city, town, and hamlet, sofa-ridden and bed-ridden women who were doomed to helpless invalidism under the label of "weak spine," of "spinal irritation," of "irritable womb," or of "chronic ovaritis." So countless were these cases, in the young and in the old, in the married and in the single, in the fruitful and in the barren, so much misery was entailed on the sufferer and on her kin, so many homes were blighted, so powerless was the medical profession to give help, that the pathetic lament of the Hebrew prophet could not have been better applied than to this great and wide-spreading scourge, "Is there no balm in Gilead? Is there no physician there? Why then is not the health of the daughter of my people recovered?" Yet now I think myself safe in the assertion that very few of these cases are incurable, and that no other discovery in medicine has raised so many women from their beds and restored them to lives of active usefulness. It is the miracle of modern therapeutics.

It is, however, essential that if treatment of this kind is to prove useful it should be adopted in properly chosen cases only, and that when it is attempted it should be done thoroughly and well. Constant failures arise from neglect of one or other of these points, especially of the latter. There is much that is disagreeable about this treatment, at least in appearance; especially the removal of the patient from her usual domestic surroundings, and her seclusion in a properly managed medical home. This is naturally disliked, and it leads to much expense. Pressure is, therefore, put on the medical man, to which he is often weak enough to yield, to treat the case in what is called "a modified way," by "trying a little massage" (this being one of the remedial agents) at the patient's own home, or in some other way to try to play "Hamlet" with the part of Hamlet left out. The inevitable consequence is failure and disappointment, a really good and valuable method of treatment is discredited, and the patient's state is made worse rather than better. I have seen so much of this that I cannot too urgently insist on the necessity of thoroughness in any attempt to carry out this means of cure.

An interesting question in relation to diseases of the nervous system in **gynæcology** arises in connection with insanity. Some have held that insanity may actually depend on morbid conditions of the reproductive organs; and it has even been suggested that for the cure of certain forms of insanity associated with pronounced sexual aberrations—such as excessive masturbation and erotic manifestations—the uterine appendages should be removed by operation. Of this alleged connection I have never been able to find any reliable evidence at all. Of course insane women are liable to uterine disease as sane women are;

and when they have marked disease of the reproductive organs, of whatever type, it should be appropriately treated, whatever the condition of the mental functions. Inasmuch as the medical staff of asylums are rarely expert in gynæcology, it is likely that where so many women are congregated together there may be found a considerable amount of undetected pelvic disease which should be made the subject of treatment.

In a paper on this subject Brown contends that fully 25 per cent of the female patients in asylums in the United States suffer from some form of pelvic disease. If this be true, it follows that alienist physicians should not neglect the study of gynæcology more than any other department of medicine. But while this may be admitted it does not follow that the one has any direct connection with the other. Unhappily it has been very common to revert in a haphazard way to **operative interference**, which, in my opinion, is unscientific, unnecessary, and often hurtful. The excessive masturbation and various erotic manifestations so common in certain types of insanity are, it cannot be reasonably doubted, phenomena of central, and not of peripheral origin; to remove the ovaries or tubes by way of curing them seems to be altogether unreasonable. It may be laid down as an axiom, which is consistent with the most generally received opinion of the profession, that no operation of this kind is permissible in an insane patient unless some structural lesion exist which would call for or justify the operation were the patient sane. Of the uselessness of such a procedure a marked example is given in Case IV. of Brown's paper above referred to.

There are other forms of neurotic disease, however, in which this operation has also been recommended and performed, in which, in my opinion, it is still less admissible. Of late years, unhappily, it has been a not uncommon practice to remove the uterine appendages in various intractable forms of functional neurosis, not because they showed any kind of structural disease, but because the neurotic condition had previously resisted all ordinary means of treatment. In a paper on this subject, published in the thirty-third volume of the *Obstetrical Transactions*, I have fully discussed this procedure, and have brought forward evidence to show its utter uselessness. It is impossible to speak too emphatically in condemnation of a rash and irretrievable experiment of this kind.

The only class of case in which such operations have any reasonable claim for consideration are those of hystero-epilepsy, or other very severe forms of nervous disease, which are regularly aggravated at the menstrual periods, and may therefore be assumed to be in some way connected with that function. It does not follow that because such cases are worse during menstruation, when all the bodily functions are naturally in a state of unstable equilibrium, that they depend upon it. Still the supposition that the artificial production of the menopause should have a curative effect in such cases is a sufficiently reasonable hypothesis, and it is not surprising that the operation should have been often performed

in such cases. The records, however, are not satisfactory. Of the cases of this kind which have been published of late years, something like 50 per cent were complete failures; and even in a well-marked case the outcome of experience tends to show that operative interference should not be resorted to unless distinct evidence of coincident structural mischief exist.

W. S. PLAYFAIR.

#### REFERENCES

1. ALLBUTT, Prof. CLIFFORD. "The Nervous Diseases of Modern Life," *Contemporary Review*, Feb. 1895.
2. BAKER, FORDYCE. "Uterine Diseases as a Cause of Insanity," *Journal of the Gynæcological Society of Boston*, Jan. 1873.
3. BOLDT, H. I. "Cardiac Neurosis in connection with Ovarian and Uterine Disease," *American Journal of Obstetrics*, vol. xix.
4. BROWN, JOHN YOUNG. "Pelvic Disease in its Relationship to Insanity in Women," *American Journal of Obstetrics*, vol. xxx.
5. GOODELL, WM. "The abuse of Uterine Treatment through mistaken Diagnosis," *The Medical News*, Dec. 7, 1889; *Clinical Gynæcology by American Authors*, vol. i.
6. MURET. "Le rôle du système nerveux dans les affections gynécologiques," *Revue médicale de la Suisse*, June 1884.
7. NORDAU, MAX. *Degeneration* (English translation), William Heine-  
mann, 1895.
8. OHR, C. H. "Genital Reflex Neurosis in Females," *American Journal of Obstetrics*, vol. xvi.
9. PLAYFAIR, W. S. "On the removal of the Uterine Appendages in cases of Functional Neuroses," *Obstetrical Transactions*, vol. xxxiii.
10. SEMON, FELIX. "The Sensory Throat Neurosis of the Climacteric Period," *British Medical Journal*, Jan. 5, 1895.
11. SKENE. "Gynæcology as related to Insanity in Women," *Diseases of Women*, p. 929 *et seq.*
12. STORE. *The Course and Treatment of Reflex Insanity in Women.*
13. "The New Woman and the Old," *The Speaker*, Jan. 12, 1895.

W. S. P.

---

#### STERILITY

STERILITY implies that condition in a woman in consequence of which she either does not conceive, or if she conceive is unable to bear a living and viable child.

Sterility depending on generative defects in the male will not be considered here, although unquestionably a certain percentage of cases of sterility in the woman (variously estimated by writers on the subject as from 7 to 15 per cent) depends upon some such defect in the husband. The cognate subject of the sterility of a woman with one husband but not with another, when in neither there appears to be any physical defect, will be considered under the heading of relative sterility. To apply the name sterility to the incapacity to conceive which exists before puberty and after the menopause appears scarcely appropriate. Sterility under these circumstances is strictly physiological; it is not governed by the commencement or decline of menstruation, except in so far as these epochs coincide with the commencement and cessation of ovulation. Provided ovulation continue, fertility may pre-

cede menstruation, exist during intervals of its suppression, and beyond the menopause. But, although the capacity to conceive may continue until menstruation ceases and even for some time afterwards, in the majority of women child-bearing terminates some six or seven years prior to that occurrence. The small minority in whom conception occurs not only up to the usual time of the menopause, but also beyond it, is largely constituted of healthy women who have married late in life, and in whom there may, consequently, be an unexpended reserve of fertility.

The statistics given by writers of the proportion of sterile to prolific marriages vary much; and this is scarcely surprising considering the wide range of conditions under which marriages take place. Such conditions include the age at marriage, individual health, social habits, and the customs peculiar to countries or districts. But probably the conclusion of Matthews Duncan, whose works on this subject are classical, is fairly near the mark when he estimates that in Great Britain the proportion of one in ten represents the number of sterile marriages; that the most usual time after marriage for the first birth to occur is from twelve to fifteen months, but that three years may be allowed to elapse before any strong presumption of sterility need be entertained: lastly, he considers the most fertile period of a woman's life to extend over twelve years, from about twenty-six to about thirty-eight.

**Classification of the Conditions leading to Sterility.**—The most usual classification is into absolute and relative; another is into congenital and acquired; another into permanent and temporary. Dr. M. Duncan's division is threefold. His first class he terms the class of absolute sterility; in it he includes all cases "in which there is no child, no miscarriage, no abortion, however early"; this class, he adds, is sometimes called congenital. His second class he defines as including cases of "sterility not absolute"; by which he implies the failure to produce a viable child while there may be evidence of conception. His third class he calls relative or acquired sterility, and in it he includes cases "where a woman produces one or even several living children, but in number not according to her conditions of age and length of married life." The term relative sterility, however, is more frequently used to indicate the sterility which a woman manifests with one husband, but not with another, and in which, therefore, the fault may be on the husband's side; or, on the other hand, she may have been suffering from some defect of the generative system during the time of her earlier marriage which ceases to be potent before her second. The term relative sterility would appear to be more appropriate to these cases than to those to which Dr. Duncan applies it as the equivalent of comparative sterility. I venture to suggest the classification of cases of sterility into absolute and contingent, and each class may be subdivided into congenital and acquired.

Cases of absolute sterility will include all those in which, from organic defect of the organs concerned in the formation, transmission to the uterus, or nidation of the ova, or in the access of the spermatic fluid, conception is rendered impossible. The congenital subclass of this division will include



cases of absence of the ovaries, or of the tubes; of absence or non-development of the uterus, and of atresia of the vagina in which operation is impracticable.

In the acquired subclass will come cases of a similar deficiency in the generative apparatus, but due to non-congenital causes, or to surgical operation. The cases of contingent sterility are much more numerous, and may also be divided into congenital and acquired. The congenital subclass will include cases of defective or delayed ovulation associated with immaturity of the ovaries; of certain cases of imperfect patency of the tubes; of certain cases of malformation of the uterus, and especially of the cervix, and of such vaginal obstructions as are capable of removal. The subclass of cases of acquired origin will include cases where pathological but remediable conditions of the ovaries, tubes, uterus, or vagina, inimical to conception, have occurred subsequently to birth. In this class would also come those cases of so-called relative sterility, to which reference has been made, in which a woman does not conceive with one husband, but does with another. An extreme case of relative sterility would seem to be one in which the generative organs of both husband and wife are normal. But obviously, after all, the explanation of relative sterility may simply be that some abnormal and unrecognised condition of ovary, tube, endometrium, or vagina, present during one marriage, may have been cured, either by nature or art, before the second is contracted. Considering the causes of sterility seriatim we have then

I. CASES OF ABSOLUTE STERILITY in which there is (A) congenital organic defect of an irremediable character.

1. *In Connection with the Ovaries.* — The ovaries are very rarely absent altogether. In such cases the uterus is generally imperfectly developed also, and there is complete amenorrhœa. To attain a certain physical diagnosis of this condition is scarcely possible; but an approximative diagnosis may be made if with an ill-developed uterus we find the association of complete amenorrhœa, the absence of any indication of periodical congestion, and of the special changes characteristic of puberty.

2. Cases of *absence of the tubes* are occasionally recorded; but they are generally associated with some congenital malformation of the uterus, as might be anticipated from their common origin in the ducts of Müller. Sometimes one tube with its cornu of the uterus is absent; sometimes both. Sometimes one or both may be represented by a solid cord-like structure. Sometimes with a normal uterus the tube is represented only by a short projection from the uterine angle, and in this case the supposition is that its condition is due to some necrotic torsion in early or intra-uterine life. The diagnosis of these malformations is probably beyond our powers; but if both tubes be affected an absolute sterility must result.

3. *Complete absence of the uterus* is also a rare condition, but cases where the uterus is only rudimentary have frequently been recorded. In these cases it is generally the amenorrhœa which calls attention to the state of the pelvic organs; and on examination by the vagina, either no indication of uterus is felt at its upper end, or there may only be a

small projection representing the cervix: on further examination by the bimanual method and by the rectum the uterus may be found only as a small body of a size varying from a ridge of the diameter of a crow-quill to an organ not larger than a bean. In these cases sterility is of course absolute.

4. *Congenital atresia* of the vagina leading to absolute sterility is not common; but many cases are on record where, on account of the shortness of the pocket which represents the vagina, and of the anatomical difficulties in the way of dissection associated with the position of the bladder and rectum, it is not possible to open it up so as to reach the uterus. Not infrequently in these cases of abortive vagina rectal examination will detect also a very rudimentary uterus.

**B. In the second class of cases of absolute sterility, which includes those of acquired origin,** will come instances of somewhat similar organic defects, but due to pathological causes which occurred after birth, or ensued upon surgical operation.

1. *As regards the Ovaries.*—The destruction of ovarian tissue by inflammatory, neoplastic, or atrophic disease may be so complete as to be incompatible with ovulation. It is presumed, of course, in these cases, that both ovaries are affected, and to a sufficient extent to destroy their capacity to ovulate. This result is not very uncommon in connection with pelvic peritonitis of septic or gonorrhœal origin, or in connection with progressive ovarian atrophy; it is less common in connection with non-septic ovaritis, or with neoplasms such as malignant, fibroid, or cystic growths. Occasionally the ovaries are so completely covered with peritonitic or embedded in parametric exudations that, even if ovulation could proceed, the ova could not escape from the follicles and reach the tubes. In this class would also come the results of such operations as double ovariectomy for ovarian cystoma, and removal of the appendices either for disease in themselves, or in certain cases of uterine fibroid.

2. *In connection with the tubes* occur such cases as their complete obstruction by inflammatory pelvic exudations, or by the pressure of pelvic tumours, or by adhesive salpingitis or tubal tuberculosis.

3. The *removal of the uterus*, either from fibroid or malignant disease, or by Porro's operation, would obviously be a cause of absolute acquired sterility.

4. A similar result will follow complete and incurable *atresia of the vagina by cicatricial obliteration*, whether arising from sloughing due to a protracted labour, in connection with an exanthem, or from local injury of an accidental or criminal character.

II. CASES OF CONTINGENT STERILITY are also divisible into (A) **congenital** and (B) **acquired**.

A. Into the **congenital class** would come

1. *Cases where the ovaries* are present and free from organic disease, but *immature*; and where ovulation is either unduly delayed, or the ova secreted are imperfect. With this are often associated impaired general health and an imperfect development of the other generative

organs. The uterus is small, often anteflexed, the external genitals are of a more or less infantile character, the general signs of puberty are either absent or but feebly developed, and menstruation either does not take place at all, or occurs irregularly and scantily, and accompanied by much ovarian pain. But, contrary to what occurs in the corresponding class under the heading *Absolute Sterility*, in these cases, with the improvement of the general health an improvement may also occur both in the structure and functions of the ovaries; and with the establishment of normal ovulation pregnancy may ensue. The cases of this kind which come under notice on account of sterility are few, the state of health which accompanies the sterility being often also a bar to marriage; but occasionally such cases come for advice and treatment, and in some, improvement of the local and general conditions has been followed by pregnancy. In some, indeed, marriage has proved an efficient stimulant to an improved condition of ovaries; menstruation and ovulation have become healthily established, and pregnancy has followed. In a certain number of women, however, there is also irregular, often painful, and sometimes delayed menstruation; but instead of being associated with a general appearance of immaturity, and more or less ill-health, the physical development and the general health may both be good, and the irregular menstruation and associated dysmenorrhœa be their only troubles. In many of these cases some affection of the uterus, such as a displacement or an endometritis, may be found on examination; but, whether this be so or not, the delayed and irregular menstruation need of itself be no bar to marriage: marriage indeed, as in the previous case, is often followed by an improvement in the functions of the ovaries and occasionally by pregnancy.

2. Sterility depending upon some *congenital interference* of a temporary kind *with the patency of the tubes* is probably uncommon; but in some cases cysts are found in the neighbourhood of the fimbriated ends of the tubes which might subsequently rupture and disappear, but which, if they remained, would more or less interfere with the entrance of ova. Or the occurrence of some adhesion in the course of the tubes, due to a transient salpingitis which had disappeared with the progress of development, or to some torsion of the tube on its axis rectified by casual changes in the relative position of the pelvis viscera, may likewise be causes of contingent sterility. Diagnosis of these conditions would rarely be practicable, and they lie beyond the range of any treatment except perhaps an empirical catheterisation of the tubes, a proceeding which can hardly yet be spoken of as always safe or even possible.

3. Sterility depending upon *congenital malformations of the uterus capable of treatment* is chiefly associated with those which involve the cervix. One such malformation is an undue elongation of the cervix, which is often of a conical outline, and projects into the vagina to the extent of an inch and a half or even two inches. The os uteri in these cases is generally minute in size, round or "pin-hole" in form, and is often placed, not centrally at the end of the cervix, but rather on one

side. In a less frequent number of cases a minute os uteri is found associated with a short and rounded cervix. There are also congenital cases of greater or less stenosis of the cervical canal without any very marked malformation of the cervix, the stenosis being more frequently at the site of the outer os, less frequently at the inner os; in this latter case it is generally associated with anteflexion of the uterus. Occasionally there is narrowing both at the external and internal os, the intermediate canal being of average size; and sometimes, but most rarely of all, there is a distinct constriction in the canal itself. The relation of stenosis of the cervix to the production of dysmenorrhœa is a much-debated subject, and need not be entered upon here; but of its influence as a factor in the production of sterility I have no doubt. The accumulated clinical evidence in favour of the view that the removal of stenosis facilitates impregnation is, I believe, decisive. I have known some cases in which a single dilatation after an unfruitful marriage of many years' duration, varying from five to fifteen, has been followed by pregnancy; and a considerable number in which a series of dilatations, as may be required by the conditions of the case, has been followed by a similar result. Such cases are also recorded by Duncan. Yet, of course, this result may not follow even after complete dilatation has been accomplished; the strong probability in such cases is that some other pathological factor, besides the cervical stenosis, is present. But even if this be so, the removal of the stenosis is a useful as well as a logical proceeding, as it assists in the cure of any other conditions present which may be antagonistic to impregnation. For instance, the cervical stenosis may have led to dysmenorrhœa, or it may be associated sequentially with some congestive condition of uterus, tube, or ovary, either of which disorder in its turn may be a cause of sterility. With the relief of the dysmenorrhœa this sequence of congestions may subside, and as a result the influences hostile to conception may disappear. On the other hand, the endometritis or salpingitis or ovaritis, of which the narrowed cervical canal was the primary cause, may have been of such long standing, and accompanied by so much tissue change, that even after the cervical canal has become normal, it may be difficult or impossible to bring about a sufficiently healthy condition in the uterus or in the ovaries to permit conception.

A hypertrophic elongation of the cervix is an occasional congenital defect; and, as it simulates prolapsus uteri, it is sometimes called infravaginal prolapse. In these cases the cervix is sometimes so unduly elongated as to reach down to, or even to pass beyond the vaginal orifice, and thus to give rise at first sight to the impression that the case is one of ordinary prolapse. Sometimes this condition has not been noticed before marriage, as it causes little or no inconvenience, unless it be some sense of bearing down, and some dysmenorrhœa. But after marriage it becomes a source of marital inconvenience, and the surface becomes inflamed and possibly excoriated. That it is not an ordinary prolapse is proved by the use of the sound; and by the normal position of the body of the uterus in the pelvis, as shown by bimanual examination. Its



removal by amputation removes both the dyspareunia and a cause of probable sterility. Fertilisation in these cases is perhaps not impossible, but I have seen several such cases, and in none did impregnation take place prior to the removal of the elongated cervix.

4. Cases of contingent sterility of congenital origin include *malformations of the vagina* and of its vulval entrance.

An imperforate hymen is at once a barrier to intercourse and to conception. A cribriform hymen, or an unusually thickened annular or crescentic hymen, may also render intercourse difficult, and so may impede the occurrence of conception; but it would not necessarily lead to sterility. Occasionally, also, we meet with cases in which a transverse septum exists a third or a half way up the vaginal canal. Such a septum, if imperforate, might permit intercourse, but would obviously prevent conception; yet if an opening were present in it, permitting the exit of the menstrual secretion, conception would be at least possible, although if the opening were a minute one it would not be probable. These diaphragms probably arise from some limited adhesive inflammation of the vaginal walls in very early life; and there are grounds for supposing that imperforate hymen itself is due to adhesive inflammation, in early or even in intra-uterine life, uniting the free edges of an annular hymen. In both cases the division of the hymen or the division of the septum is necessary. Occasionally the vagina terminates in a *cul-de-sac*, and between this and the uterus a greater or less thickness of cellular tissue is interposed, with the bladder in front and the rectum behind. In many of these cases, as stated under the heading of absolute congenital sterility, to dissect through this tissue to the uterus has, for the reasons there given, proved difficult or impossible: in some cases, however, the dissection has been attempted with success; and if the uterus, tubes, and ovaries be healthy, conception becomes possible. Sometimes that rare condition, a double vagina, may be a cause of sterility. If associated with a double uterus and bifid cervix, with one cervix projecting into each vagina, the sterility may arise rather from the imperfect character of the uterus and of the cervix, the two halves of which are often abnormally developed, than from the divided vagina being a barrier to intercourse. One cervix may be quite short and rudimentary, while the other is of average size; and in one or both the os is apt to be situated laterally, and to be very minute or of an irregular outline.

Cases are also met with in which the two vaginas are so narrow as to make sterility probable, by preventing effective intercourse; a difficulty to be removed by the division of the intervening septum so as to throw the two into one. In such a case, if the uterus and organs beyond be normal, there is no further barrier to conception; but more commonly the uterus shares in the malformation. Occasionally one vagina is of average size and the other much smaller. Vaginismus may possibly be a congenital cause of contingent sterility; but as it is more frequently of acquired origin it will be considered further on.

### B. Acquired Contingent Sterility.

1. From *Abnormal Conditions of the Ovaries*. — The ovaries may be so damaged by acute or chronic ovaritis that for a time the Graafian follicles do not mature normally, and ovulation is either performed imperfectly or not at all. But in the cases belonging to this class the damage is not irretrievable. With a return to a healthy condition of the ovary, its function is restored and the possibility of conception returns. Subacute ovaritis may arise from the lesser attacks of septic or gonorrhœal infection, from limited congestive hæmorrhage into the structure of the ovaries, from a chill during menstruation, or in association with endometritis and backward displacements of the uterus. It will of course be understood, as in the other classes of cases in which the condition of the ovaries is the cause of sterility, that sterility only occurs when both ovaries are affected. But from many of the causes just enumerated both ovaries do become involved, though often one more markedly than the other; not infrequently after an attack of double ovaritis, one ovary, usually the right, will apparently recover completely, so far, at least, as can be judged by examination, while the other remains tender, swollen, and possibly displaced. And in many of these cases there is sterility, although apparently one ovary is healthy. The probability in such cases is that recovery is incomplete, and that the inflammatory attack, to which one ovary has succumbed, has also brought about some change in the structure of the other which cannot be estimated by a bimanual or other examination. Possibly also functional disturbance in one may be sympathetic with structural change in the other. In addition to ovaritis other affections of the ovaries have been referred to under the head of absolute sterility which, if less serious in extent and character, may be only temporary causes of sterility. Such would be cases of pelvic peritonitis in which peritonitic exudation, instead of forming an impenetrable investment to the ovary, is slighter in character, and after a time becomes sufficiently thin to yield to the distension of a maturing Graafian follicle, and to permit the ovule to pass through and reach the tube. Or a parametric exudation, which has pressed upon and covered up one or both ovaries for a time, may be so absorbed as to permit their function to be restored; or possibly even cystic disease may be present, but to so limited an extent that healthy tissue sufficient for ovulation remains. Temporary malposition of the ovaries, the result of an ovaritis which has led to enlargement and increased weight, and so to more or less prolapse, or the downward displacement of both ovaries which often accompanies retroversion and retroflexion of the uterus, may be a cause of difficulty in the way of the ova reaching the tube, and so lead to a temporary sterility. And, lastly, apart from tissue-changes and displacements, the ovaries may share in a general condition of depressed innervation, and perform their function as imperfectly as do other organs of the body under similar conditions of general health, whether these conditions be associated with anæmia or plethora, or some more serious morbid diathesis. Their innervation

and blood-supply being faulty, the ova they secrete will be faulty too; and sterility will continue until, with improved health, their condition, in common with that of other organs of the body, becomes normal and their function is normally performed.

2. The pathological conditions of the tubes which lead, while they continue, to sterility, would include the *slighter forms of double salpingitis*, generally of septic or gonorrhœal origin, which terminate without rendering the tubes impermeable, whether by internal adhesions or by distension with serous, sanguineous, or purulent collections. Mechanical interference with the tubes by pressure from some *pelvic tumour* would cease as a cause of sterility; either by removal of the latter (were it undertaken for any reason), or by some such shifting of its position as might occur with either a pediculated fibroid or an ovarian cyst.

3. But much more frequent and so more important than any affections of the tubes in leading to contingent sterility are *certain diseases of the uterus*. And chief among these are *endocervicitis, endometritis, and metritis*. The influence of a severe and established *endocervicitis* in favouring sterility is well marked. The swollen and abraded lining membrane and the tenacious muco-purulent discharges offer together a distinct obstruction to the ingress of spermatozoa, while the character of the inflammatory discharges is prejudicial to their life. The word obstruction is used here in its widest sense; it is not limited simply to mechanical obstruction, but includes whatever obstacles may be offered by the hyperæmic condition of the tissues of the cervix to that physiological dilatation of the canal which favours the ascent of the spermatozoa into the uterine cavity. That the obstructive influence of endocervicitis is not simply hypothetical is supported by extended clinical evidence and the observations of numerous authors. Repeatedly on the cure of endocervicitis pregnancy has ensued in a patient previously sterile. With *slighter attacks of mere cervical catarrh*, which is an extremely common malady, the hindrance to conception is proportionately less. With *chronic endometritis*, if this term be applied to inflammation of the lining of the uterine cavity, the influence on sterility is somewhat different; for, on account of the swollen condition of the endometrium, there is probably also obstruction to the ascent of the spermatozoa through the uterine cavity, and to their entrance into the tubes; especially if the membrane around the orifices of the tubes be involved. The inflammatory secretions of the cavity are also inimical to the life of the spermatozoa; while a further effect of endometritis is the strong tendency which exists with it to abortion on account of the diseased endometrium failing to offer a safe nidus for the support and sustenance of the ovum. The forms of endometritis known as membranous and villous, and that due to syphilis, are particularly hostile to the occurrence of pregnancy; and if conception should occur, abortion is almost certain.

In *chronic metritis* it is probable that the tissue of the uterus is never affected without the endometrium being also involved, either in the interior



of the body or in the cervical canal, or in both. In endometritis, on the other hand, the muscular tissue immediately subjacent to the mucous membrane may only be affected; but it is often the starting-point of a general metritis, aided by abnormal states of the general health, and by certain conditions of the portal system and heart which lead to pelvic hyperæmia. However started, metritis, when chronic, becomes a well-recognised cause of sterility. The term metritis, without reference to the disputed point whether the muscular fibres of the uterus are capable of inflammation in the strictly scientific sense, is here used to include the results of chronic hyperæmia in the increase of connective tissue formation; and to include also the condition sometimes spoken of as subinvolution of the uterus, which I believe to be essentially a chronic metritis whose starting-point has been some traumatic or septic influence connected with labour. In these conditions of uterus the sterility which frequently accompanies them is due not merely to the endometrial changes already referred to, which interfere with fertilisation and dispose to abortion, but to the slow inflammatory changes which spread to the tubes and ovaries, which interfere with ovulation or with the transit of ova through the tubes, and, if complete, remove the case from the hopeful to the hopeless class. Hyperplasia limited to the cervix would affect impregnation in so far as the calibre and the condition of the lining membrane of the cervical canal are affected, and in proportion to the loss of elasticity in the tissues of the cervix itself.

*Versions and Flexions of the Uterus.*—In cases in which the uterus is simply displaced, either backwards or forwards, without any bend on its own axis, if there be no associated metritis or endometritis, I do not think such displacements would have much hostile influence on conception, unless a backward position of the fundus with the os directed towards the anterior vaginal wall should interfere with the access of spermatozoa into the cervix, or should also cause a displacement of the ovaries from their normal relation to the fimbriated ends of the tubes. Possibly also displacement may, in intercourse, prevent that adaptation of the cervix to the male organ which some writers hold to be favourable, if not essential, to impregnation, and which by Rainey was believed to be brought about, under normal circumstances, by the action of the round ligaments. But cases of version without flexion are comparatively few, at all events as regards cases of retroversion, which, unless as a stage of prolapse, is rarely seen without some associated flexion. When versions exist there is a tendency to progressive uterine hyperæmia with the results, as regards conception, indicated under metritis. But where flexion is added to version and the uterus is bent on itself, the tendency to the dysmenorrhœa of uterine colic is rarely absent, and more or less of endometritis and chronic metritis result.

Anteversion and ante flexion are recognised as but an exaggeration of the normal state and position of the uterus in early life, prior to puberty; and, in cases in which this condition persists, the uterus as a whole not infrequently remains infantile in character with a small



pointed cervix and a minute os. In these cases dysmenorrhœa is the rule, and not infrequently amenorrhœa more or less complete, showing probably an immature condition of the ovaries also; should marriage take place, sterility is almost invariable. But these cases are not hopeless. Both by medicinal and local treatment the condition may be improved, normal menstruation become established, and the uterus and its appendages may take on a distinct if slow improvement. It has been stated that in rare cases versions may exist without any associated flexion; but still more rarely, if ever, is there flexion without some co-existing version. And as with anteflexion there is generally anteversion, so with retroflexion there is almost invariably retroversion; but contrary to what obtains in anteflexion, retroflexion is rarely congenital. It is comparatively rare in the nullipara, but in the multipara very common; and this is so because its most frequent starting-point is to be found in the conditions of the puerperium. Its influence on sterility is twofold: firstly, the flexion as a rule produces a virtual stenosis of the cervix, which constitutes an initial difficulty in the way of impregnation. In cases in which with flexion there is no stenosis this difficulty of course does not occur; but where there is stenosis dysmenorrhœa is rarely absent; and in its train come, secondly, endometritis and chronic uterine hyperæmia with leucorrhœa, menorrhagia, and, as a rule, sterility. It has frequently happened that on reposition of the uterus and its subsequent return to a healthy condition, pregnancy has resulted even after a long interval of sterility. It must not be forgotten, also, that if pregnancy occur in cases where some retroflexion exists, but in which the uterus continues fairly healthy, there is always a risk of its premature termination by incarceration of the fundus in the sacral cavity, and by the pathological changes which then ensue. The last displacement to be noticed in connection with sterility is *prolapse*. In the various degrees of incomplete prolapse of the uterus there is not much interference with the possibility of conception if the organ itself continue healthy; but if prolapse become associated with chronic metritis, a tendency to sterility, in proportion to the extent of the metritis, will ensue. In complete prolapse endometrial and metritic changes are generally present which, if impregnation took place, would militate against a normal continuance of the pregnancy. But the majority of these cases of complete prolapse occur in women who have passed the usual limits of child-bearing.

Occasionally an *elongation of the cervix* takes place in women after child-birth, which appears to be secondary to congestive changes in the cervix resulting from some pathological incident of labour, and resembling in character those cases of congenital elongation, or infra-vaginal prolapse, which have already been considered. In these the tendency to sterility is not so strongly marked as in those of congenital origin; but from the accompanying endometrial changes there is a distinct tendency to early abortion, and so practically to sterility.

Of the *uterine tumours which promote sterility* those requiring the chief consideration are *fibroids*; and their precise influence, as regards sterility,

will depend not only upon their size and position, but also upon the local changes they produce within the pelvis. Subperitoneal pediculated fibroids by themselves, if the uterus be otherwise healthy, will not necessarily interfere with impregnation, nor perhaps with the process of pregnancy, although there must always be the possibility that by some casual twist of the pedicle uterine disturbance may be set up, and premature labour either come on or even require induction if any symptoms of strangulation of the fibroid occur. A case of this kind occurred in my experience where, even after pregnancy and delivery had been safely accomplished, an accident led to partial severance of a pediculated fibroid, followed by intraperitoneal hæmorrhage and peritonitis, which necessitated abdominal section, and hysterectomy.

When fibroids are situated in the uterine wall they may have an obstructive influence on the possibility of impregnation if their situation be in or near the cervix, and they press upon, distort, or harden the canal. This, however, is their least common position. But not infrequently, if in the anterior or posterior wall, they will also affect the canal, though to a less degree; sometimes, however, in the case of multiple fibroids to a very high degree, the uterine tissue around and between the fibroids being dense and unyielding in character. But supposing this not to be so, and that they do not interfere with the physiological dilatation of the canal, and that impregnation occurs, there is still the great probability that the highly vascular and hypertrophied lining membrane, which coexists with a fibroid projecting into the interior, and the resulting menorrhagia, may prevent the normal fixation of the ovum. Even if these initial difficulties do not occur, and the ovum continue to develop, there are yet great probabilities of early abortion or premature labour.

And beyond the influence upon the prospects of pregnancy due to the effects of fibroids upon the uterus itself, we have also to consider the effects of pressure exerted by them upon the other pelvic viscera, including the tubes and ovaries; especially if the tumour be large, or if it be multiple. Under these circumstances the ovaries are not infrequently displaced and pressed upon, and the tubes twisted or flattened; and often also more or less pelvic peritonitis supervenes, leading to adhesions and matting together of many of the pelvic contents.

In the case of *polypi* a pediculated submucous fibroid thus projecting into the uterine cavity has a twofold influence upon the causation of sterility. If the cavity of the uterus be much enlarged, and if the polypus spring from the fundus and press upon the orifices of the tubes, there is a difficulty in the way of the spermatozoa either reaching or entering the tubes. However, supposing this not to occur, and fertilisation to take place, a difficulty might arise in the passage of the fertilised ovum into the uterine cavity. It is believed, indeed, that in some cases such obstruction has been a cause of tubal gestation. Supposing, lastly, neither of these obstructive difficulties to occur, there would still be the endometritic condition of the lining membrane of the uterus to

contend with, kept up by the presence of the polypus and its attendant leucorrhœa and menorrhagia, both highly provocative of abortion.

In the case of cervical mucous polypi the tendency to sterility is partly from the obstruction offered by the polypus itself which may act like a ball-valve against the ingress of the spermatic fluid, and still more from the catarrhal condition of the cervix. In the case of large fibroid polypi projecting through the cervix and filling the vagina, sterility is almost certain until the removal of the polypus has made impregnation possible.

In *carcinoma of the uterus* in the early stage, whether the disease have attacked the vaginal aspect of the cervix or the cervical canal, sterility is certainly not absolute. Pregnancy in such conditions occasionally occurs. But in the later stages, when the cervix is the seat of a soft, friable, and easily bleeding papillary growth, or when its canal is filled with a soft vascular growth, or is excavated and granular, or again when the body of the uterus is affected, pregnancy is unlikely. In many cases of cervical carcinoma, in which pregnancy has occurred, the amount of the disease at the date of fertilisation was probably not large; for its growth is largely stimulated by the heightened uterine vascularity which accompanies gestation. The causes of the sterility in the majority of cases of carcinomatous cervix are perhaps partly mechanical, according to the extent to which the cervix was occupied with cancerous growth, and partly the effect of cancerous discharges on the vitality of the spermatozoa. In many cases, also, intercourse is followed by so serious and sometimes by so alarming a hæmorrhage that there is but slight prospect of fertilisation. In cases in which impregnation does take place there is always a tendency to abortion.

4. Lastly, in the *vagina* and *vulva* causes of sterility are not infrequently met with. *Vaginitis* may be a factor in the causation of a temporary sterility, both by rendering intercourse too painful to be borne, and by the excessive acidity of the inflammatory secretions being fatal to the spermatozoa. Undue *shortness of the vagina* and a *ruptured perineum* may also interfere with the proper retention of the seminal fluid.

*Tumours of the vagina*, even if innocent like cysts or fibroids, offer a mechanical obstacle to normal intercourse, and also, by provoking an excessive leucorrhœal discharge, endanger the vitality of the spermatozoa. In *sarcoma and carcinoma of the vagina* there is an additional adverse factor in the frequent hæmorrhages and, ultimately, in the necrotic discharges which occur with the advance of the disease. The presence of a *vesico-vaginal fistula* is not necessarily, perhaps, a cause of sterility, but the probability of its being so is considerable.

Certain diseases of the *vulva* are mainly operative by way of dyspareunia, which either prevents marital intercourse altogether, or renders it less efficacious for fertilisation. Such are *vulvitis*, especially if it be of the follicular type and accompanied by scattered small ulcerations generally superficial in character, but highly sensitive to any touch. *Cystic enlargement or abscess of one of the glands of Bartolini* generally renders intercourse impracticable until it is cured. *Eczema* affecting the labia



majora, with which is often associated a sensitiveness so acute that even sitting is painful, often renders any attempt at intercourse impossible. *Pruritus*, whether inflammatory or neurotic, is likewise a cause of sterility in proportion to the dyspareunia it produces; and this it is particularly apt to do, as the clitoric area of the vulva is generally chiefly affected. *Caruncle* of the urethra is another and very persistent cause of dyspareunia. So exquisitely sensitive is it in some cases that even the passage of urine gives extreme pain, and intercourse is impossible. Occasionally on the vulva, and not infrequently on the remains of the hymen, are found little bright red vascular patches of an extreme sensitiveness. Not infrequently these are gonorrhœal in origin, and found in association with inflammation of the orifices of the ducts of Bartolini. These patches are exquisitely sensitive, and are very generally barriers to intercourse. *Hypertrophic enlargement* of the labia majora, or, more rarely, of one or other nymphæ, has occasionally been so considerable as to interfere with intercourse. And, lastly, there is the condition termed *vaginismus*, by which is understood a spasmodic contraction of reflex origin of the muscular fibres surrounding the vulval orifice of the vagina. In a few of these cases, and for the most part in patients of a highly neurotic type, no local abnormality can be detected; but in the majority local pathological conditions are present which induce more or less violent spasm of the sphincter on the least touch. Whether the hyperæsthesia be neurotic, or dependent upon some obvious pathological condition, the resistance in some of the worst cases to any attempt at intercourse is extreme; the spasmodic contraction at the vaginal entrance is violent, and, if the attempt be persisted in, epileptiform convulsions or attacks of syncope may occur. In these severer cases sterility is, of course, invariable. Occasionally these cases come before the courts of law as a ground for divorce, and I gave evidence in one such case in which, for the first time in English law, a divorce was granted for what was but a virtual obstacle to the consummation of marriage. Any attempt at intercourse rendered the respondent for the time being practically maniacal. Among the pathological conditions which are more usually found to coexist with and to induce this singular sensitiveness are an undue rigidity of the hymen, an inflamed condition of the membrane occurring either before or after its rupture, unhealed fissures of the hymen following its rupture, eczema of the vulva, and small ulcers about the inferior vulval commissure or at the edge of the perineum, vascular excrescence of the urethra, fissure of the anus, and occasionally some form of uterine displacement or periuterine inflammation.

It will be understood, of course, that these contingent cases differ from those of the absolute class, in that there is always the possibility of impregnation in spite of the existing pathological conditions. If in spite of a vaginismus insemination occur at the orifice of the vagina, it is quite possible for spermatozoa to reach the uterus, and under favourable circumstances fertilisation may be effected. And in the case



of a cervical catarrh, attended with tenacious and obstructive discharge, occasionally the canal may be fairly healthy, may be free from discharge, may permit a normal dilatation, and fertilisation become possible.

In the case of vaginismus, again, especially where the cause is neurotic, the pain and consequent dread felt at one time may be absent at another. I have known more than one case where sometimes on attempt at intercourse the patient has not only resisted but violently attacked her husband, while on other occasions she has received him without opposition. In one case of the kind the patient would sometimes spring out of bed at her husband's approach, while at another time she would be quiescent and unresisting.

It may be stated here that neither sexual desire nor sexual pleasure is essential to impregnation. Impregnation has been known to follow criminal and forcible assaults, with fright and horror and suffering as their necessary concomitants. It is also certain that desire may exist without any pleasure in intercourse, and that pleasure may occur without desire. Under various circumstances, such as unhappiness in the relations between husband and wife, any feeling of desire may be in abeyance, and yet the act itself be pleasurable; and sometimes, even if there be a strong feeling of antipathy to the generative process altogether, the act itself may not be unattended with pleasure. On the other hand, desire may exist, but from the presence of some of the pathological conditions named any feeling of pleasure may be more than neutralised by pain and suffering. Occasionally we meet with patients in whom there is neither desire nor pleasure, who are always apathetic and passive. But in all these cases, whether desire or pleasure or both be absent, fertilisation may occur. In several cases in which one or other or both of these defects were present in women in whom pregnancy had not occurred, I have found some condition present which, while insufficient, perhaps, to render intercourse actively painful, has evidently, and in a way difficult to explain, interfered with its pleasure: the explanation may be that any faulty link in the chain of incidents which constitutes the entire generative process may interfere with the completeness of those physiological sensations which accompany its initiation. And still further, I have known several sterile women, with a more or less active dislike of intercourse, and to whom it gave no pleasure, who found both pleasure and desire after some pathological condition was remedied, such as a cervical stenosis by dilatation, or a retroflexion of the uterus by replacement. But although desire and pleasure are not essential to impregnation, there can be no doubt that they are favourable to its occurrence, as showing that the organs concerned are healthy, and their function likely to be healthily performed. The absence of pleasure is probably, therefore, significant of some pathological condition; although it is quite possible that to ascertain in what it consists may in many cases be beyond our diagnostic powers and beyond the application of any remedy. Excess of sexual excitement, on the other hand, is prejudicial to fertility in so far as it induces certain pathological

results, such as a sustained congestion of the uterus and its appendages, leading to ovaritis, and with it to defective ovulation; or to salpingitis, and with it to more or less obstruction to the descent of ova and the ascent of spermatozoa; or to metritis, and with it a tendency to the occurrence of abortion.

With the treatment of these various pathological conditions this article does not deal: this is discussed in other sections of this System in connection with the several pathological conditions. In cases of absolute sterility, whether congenital or acquired, there is, of course, from their very nature no treatment possible; but in the larger number of the contingent cases much may be hoped for from successful treatment. Here the question of diagnosis is of the essence of success: yet in many cases it is beyond our powers. A very slight change, for example, in the mutual relations of ovary and tube, quite beyond our capacity to diagnose, may prevent ova entering the tube and allow them to drop into the peritoneal cavity and be lost; or a faulty condition of the ovary itself, depending possibly upon some defective local innervation, and beyond the scope of any possible physical diagnosis, may be the cause of imperfections in the ova. In a great many cases, however, a painstaking investigation will disclose some faulty link in the chain which connects insemination with fertilisation. We must also remember that the causes of sterility may be multiple; and that, because one has been removed without the occurrence of pregnancy, it is not necessary to regard the case at once as hopeless. A cervical stenosis may be cured by appropriate dilatation, and yet imperfect ovulation, depending on a chronic ovaritis or the condition of the general health, may remain. A dyspareunia, sufficient to prevent intercourse, depending upon the presence of a vascular caruncle of the urethra, or an inflamed hymen, may be cured by the removal of the caruncle or the relief of the local inflammation; and yet conception may not occur because of a viscid catarrhal discharge blocking the cervical canal, or of a gonorrhœal salpingitis which has resulted in tubal stenosis. It must not, of course, be forgotten that in a certain number of cases (variously estimated at from eight to fifteen per cent) it is the husband who is at fault; but of the nature and cause of these faults no consideration is undertaken in this article, which is written from the point of view of the gynæcologist, and treats only of the pathological conditions with which he has to deal.

A few words may be given to the consideration of certain remedial measures which may be proposed, often somewhat empirically, either without a sufficiently careful investigation of the possible causes of the sterility, or after such investigation has disclosed nothing obviously wrong. Certain watering-places are frequently recommended as cures for sterility, and in many cases the desired result has been obtained; but probably only when the waters happen to be adapted to the cure of the pathological condition on which the sterility depends.

Where some chronic congestion of the pelvic viscera, associated with a gouty diathesis or liver troubles, indicates an alkaline and saline treat-

ment, Brides les Bains, Kissingen, and Ems may be useful. Where some previous inflammatory attack has produced parametric thickening of the broad ligaments, with associated subovaritis and metritis, the waters of Kreuznach are of distinct value. In cases of uterine fibroids their value would appear to be less. Where anæmia exists, with scanty catamenia, impaired general health, and probably imperfect ovulation, the waters of Franzensbad, of Schwalbach, of Pyrmont, and of Spa are indicated. The Marienbad waters, including, as they do, both alkaline and ferruginous springs, can be resorted to according to the indications of the case [*vide* art. "Balneology," *Syst. of Med.* vol. i. p. 318]. And, lastly, if the general health be at fault, and more especially the nervous system, without any predominance of anæmia or obvious pelvic mischief; and if there be a dyspareunia, of neurotic origin, a residence for a time in mountain air has been found beneficial.

As to medicines for sterility, apart from such as influence its recognised pathological causes, there is probably none of any certain value: but possibly in some cases where, without organic defect or functional disorder or impaired general health, there may be some limited failure of ovarian innervation, and so a secretion of defective ova, the use of an ovarian extract may be tried in the same way as thyroid or thymus or splenic extracts have been given in cases of defective function in the corresponding glands.

Of artificial fertilisation it need only be said that Sims, who wrote on this subject, appeared at one time to have much hope from its adoption; but during two years, in which he carried out fifty-five injections, he succeeded in one case only, and in this an early miscarriage occurred. He subsequently gave up the practice, and no writer has advocated it since. The least that can be said about such a suggestion is that it is wholly empirical. The cause of sterility being, in the great majority of cases, of the contingent class of pathological origin, its remedy is to be sought rather in minute diagnosis.

Many of the causes named are so slight in themselves, and of such slight importance to the patient's health, that unless she seek advice on account of her sterility she may consider herself in good average health; and without any local defect likely to be a cause of sterility. A persistent but not excessive leucorrhœa, a moderate dysmenorrhœa, a tendency even to menorrhagia, may all be thought of little importance, or not sufficiently important or unusual to need advice; and yet may be the indication of a pathological condition adequate to account for sterility.

Two or three points in connection with the subject generally remain for consideration. *Obesity* has been held to be adverse to fertility, but without any very decided observations to support the opinion. Probably its concurrence with sterility may be due to pathological conditions which exist with the obesity, or as its result, rather than to the obesity itself. With obesity not infrequently both portal and cardiac disorders, sufficient to lead to pelvic congestion, are associated; and, as a result, dis-

turbed function of the pelvic organs would follow. There would also be the possibility of a heavy omentum pressing upon the pelvic contents, and interfering with the normal relation between the ovaries and tubes.

*The influence of alcohol* in excess is also held by some to be adverse to fertility; if so, this would probably rise from a somewhat similar series of pathological incidents. Following upon portal congestion would come congestion of the pelvic viscera, with its various adverse possibilities in connection with a fertile ovulation; and there would also be a gradual deterioration of the general health, leading to disordered innervation and to inefficient performance of the functions of the body generally.

*Excess or deficiency of menstruation* is regarded by some writers as unfavourable to fertility. Impregnation may certainly take place whether the catamenia be profuse or scanty; but both these extremes point to some pathological condition of the uterus or its appendages, or to some disorder of the general health which may be unfavourable to conception.

*The marriage of near relations* has also been held to be adverse to fertility, but probably without any very good grounds; and when in such a case a sterile marriage has resulted it would probably be explicable by some pathological tendency common to both husband and wife, and affecting in a similar way the various functions of the body, and among them those of the generative system. If both husband and wife, though related, are free from any common diathetic taint, and of average health, there is no reason why sterility should attend their union.

*Marriage with heiresses* has been regarded by some writers as undesirable from the point of view of fertility. If an heiress be the sole survivor of a family (and the fact of her being an heiress in many cases signifies as much), this circumstance may indicate some family pathological tendency which has led to the premature deaths of other members of the family: these tendencies she may share, her generative in common with her other functions may be abnormally performed, and her marriage from the point of view of fertility may be undesirable. But if she have become an heiress less as a result of an undue pathological mortality among the members of her family than from accidental circumstances, such as the chances of travel, war, or epidemics, and if her health be good, there would appear to be no very valid reasons against her marrying, even if the perpetuation of a family name were specially desired.

In conclusion it may be remarked that, although with the lapse of every succeeding year after the third from marriage, without the occurrence of conception, the prospect of child-bearing becomes less, yet if no obvious cause of sterility be discoverable, either absolute or contingent, the patient may still be encouraged to entertain some hope. There are sufficient cases on record of conception occurring after a marriage sterile even for fifteen or twenty years, to prevent entire despair; a slight change in the mutual relation of the pelvic viscera; a slight improvement in some local innervation; a subsidence of some little chronic congestion in



ovary, tube, or uterus, even after the lapse of many years, may rectify the minute pathological condition on which the sterility depended.

HENRY GERVIS.

#### REFERENCES

1. BARNES, ROBERT. *Diseases of Women*, 1878.—2. BUDIN, PAUL. *Obstétrique et Gynécologie Recherches cliniques*, 1866.—3. DORAN. *Tumours of the Ovary*, 1884.—4. DUNCAN, J. MATTHEWS. *On Sterility in Women*, 1884.—5. *Ibid.* *Fecundity, Fertility, Sterility*, 1866.—6. GALTON, FRANCIS. *Hereditary Genius*, 1867.—7. SCANZONI, F. W. VON. *Diseases of Women*. Translated from the French of Dor and Socin, 1861.—8. SIMS, J. MARION. *Clinical Notes on Uterine Surgery*, 1866.

H. G.

---

### GYNÆCOLOGICAL THERAPEUTICS

It is a mistake to treat Gynæcology as a narrow specialism. Successful treatment of pelvic disorders depends upon a correct view of the organic and functional integrity of the other organs of the body. It involves also a somewhat close investigation, and very often considerable modification of the habitual régime of the patient. In other words, it is based on general principles as well as on local lines.

The successful gynæcologist is not one who treats the pelvic disorder as an isolated event, but who views it either as arising out of an existing (or pre-existing) constitutional state, or faulty régime of the patient; or, if purely local in its origin, as likely sooner or later to injure the general health.

Frequently we have to deal with a "vicious circle," with local and constitutional states so interacting, that no real improvement is possible until the "circle" is broken, and both the general and local states receive their due shares of attention.

Thus the circulation, the digestion, and the other important systems may influence or be influenced by the pelvic organs; and the woman must be treated as a whole, able only to enjoy perfect health as regards one set of organs, when all her other organs are equally healthy.

Professor Clifford Allbutt has drawn attention to the influence of the nervous system on the symptomatology and treatment of Gynæcology. He says "the uterus has its maladies of local causation, its maladies of nervous causation, and its maladies of mixed causation, as other organs have." This element of neurosis it is which, whether cause, complication, or effect, tends to baffle the gynæcologist; and, if disregarded, will prevent the complete cure of a patient whose pelvic organs seem to have regained their organic and functional integrity; especially if attention have been paid correctly, but too exclusively, to these viscera.

Instances of such complexity could be multiplied indefinitely, but

would merely serve to emphasise the fact that general therapeutics are essential to the efficient treatment of almost all cases which, owing to the predominant, or perhaps the almost exclusive, pelvic character of the symptoms, come, correctly enough, under the term "gynæcological."

Notwithstanding this, it is obviously impossible to do more than to indicate briefly those therapeutic methods which are immediately pelvic in their application; and the more general methods must be rigidly omitted from consideration.

*The subject of Gynæcological Therapeutics may be discussed under the following subdivisions:—*

1. General Hygiene (Routine, Clothing, Diet, Baths, Exercise, etc.).
2. Rest (General, Local, Physiological).
3. Drugs (General and Special).
4. Balneology.
5. Local Therapeutical measures:—(i) Heat and Cold: (a) External and (b) Internal application. (ii) Medicinal agents: (a) to skin; (b) to vulva; (c) to vagina; (d) to uterus.
6. Blood-letting.
7. Operations, General measures: (i) Antiseptics; (ii) Preparation of patient; (iii) Anæsthesia—(a) Local, (b) General.
8. Therapeutical operations: (i) Dilatation of uterus; (ii) Curetting the uterus.

**I. General Hygiene.**—Dr. Robert Barnes' dictum remains true, "Occupation, physical and mental, is the great panacea; something to do is the great female cry."

There are two conditions of life which tend to aggravate, if not actually to produce pelvic disorders. The first is luxury, which allows a woman to spend her existence in indolence and ease, leaving her mind a prey to morbid introspection, and her body prone to functional debilities, which tend in the one case to hysteria, in the other to neurasthenia. These, especially the latter, are much more frequently observed in the wealthier classes. The second condition of life which aggravates pelvic troubles is continuous over-exertion; this is chiefly found in women of the poorer classes, who have not the opportunities of adequate rest, or the change of environment after illness and parturition, which their richer sisters can ensure.

The mode of living ought then to be between these two extremes of indolence and over-exertion. The mind should be free from anxiety and strain, yet at the same time actively occupied with some healthy intellectual pursuit, which should prevent mental stagnation; the body should be stimulated by exercise suited to age, tastes, and circumstances; and, above all, the importance of functional regularity should be insisted upon.

The human functions of menstruation and gestation are instances of rhythm in the movements of nature; the intermissions of the hollow viscera occur in cycles, which are approximately rhythmical; the more regular the woman in these functional observances—in defæcation, micturition, the toilet of the skin, and exercise both mental and physical—the healthier she will be; and regularity of meals and sleep, both as regards time and duration, are no less important.

A daily cold bath or cold sponging heightens arterial tone, strengthens

the heart's action, increases the corpuscular richness of the blood, and the hæmoglobin richness of the corpuscles, and is at the same time a powerful nerve stimulant. Occasional hot baths, as means of more perfect cleansing, are also essential, and should either be taken just before bed; or, if at other times, should be followed by cold sponging and rough towelling. The daily routine, especially as to baths and exercise, may need some modification during the menstrual period or in pregnancy.

The women of all centuries are affected, more or less, for evil or for good, by the fashions of their generation. *Clothes* should be light and, as regards underclothing, loose in texture; made either of silk or, far better, of wool; or, if these cannot be worn, of loosely woven cotton, such as "cellular clothing" or "flannelette." Clothes should not prevent the freedom of muscular and respiratory action, and should uniformly cover all parts, not leaving the genital organs to be the least protected, as in the usual arrangements of underclothing.

*Exercise* should never be excessive, and should be very moderate during menstruation. There are certain forms of exercise, such as rowing, which are less suited to women than to men; but even these are harmless if taken carefully during menstruation. Skill in such exercises should be acquired in early life, so as to avoid heavy strains and falls. It should always be remembered that active exercise in moderation does far less harm than passive exercise; for when actively engaged, all the muscles of the body are at "attention," not "off guard" and relaxed. Thus riding and driving are often better than being driven, and bicycling is better than the pedal sewing machine, in which the leg muscles only are engaged. In cycling it is most important that the saddle should be wide enough to reach beyond the ischial tuberosities, which are wider apart in some persons than in others; otherwise the perineum gets superficially hard and rigid, and the pelvic contents are unduly affected. Pneumatic broad or double saddles, with a very slightly elevated peak, are therefore the best.

There are other forms of beneficial exercise, such as dancing, which are harmful only when indulged to excess, or in rooms where the air is rendered impure by overcrowding, or by gas. Football and gymnastics, unless of the parlour variety, are quite unsuited to adult women.

## 2. Rest. — *General*; *Local*; *Physiological*.

In no department of medicine is "rest" more essential, whether in prophylaxis or treatment, than in gynæcology. In the pelvis as elsewhere, pain and disordered function are indications for rest.

*Pelvic rest* may be obtained in two ways: by the complete quiescence of the individual, or by a local quietude. The former is a method which the leisured class can usually adopt, but is one of which the poorer classes, unless in a hospital or "home," are unable to avail themselves. For this reason some surgeons have considered it right to treat hospital patients more radically than private ones, and would, for example, remove the uterine appendages for certain varieties of tubo-ovarian

disease in a woman whose livelihood depends upon her activity; whereas a lady with leisure and means might undergo a prolonged course of rest and palliative treatment, with a view, if possible, to avoid that operation. As a routine practice this is wrong, though in individual cases it sometimes seems unavoidable. Each case must be judged solely by its own needs, and independently of the social or domestic engagements and desires of the patient, which often seem to her more important than medical advice.

*Local rest*, so useful in cases of uterine displacements with congestion, may sometimes be obtained by means of the various forms of pessary, which may permit the patient to take active exercise, whilst the pelvic congestion, or the relaxed state of the uterine supports, are being simultaneously improved by constitutional or other local measures. Such "local" rest is particularly useful where the patient belongs to the working classes and cannot obtain "general" rest.

Whatever mechanical means be used, general or local, *physiological rest* can only be obtained by total abstinence from coitus; and unless the husband will co-operate in this respect, all our efforts may prove fruitless. Sometimes, however, it is either unnecessary or undesirable to enjoin sexual continence.

**3. Drugs.** — A wide and precise knowledge of the action and uses of drugs is essential in the treatment of disease, whether of one set of organs or another. This is especially true in gynæcology, where, as already indicated, so much depends upon the functional and organic integrity of the rest of the individual. By the stimulation of extra-pelvic secretory organs great relief can be afforded to the intra-pelvic viscera. A few words, then, may be devoted to the principles which should guide us in the administration of the more general drugs.

*Purgatives.* — In no class of diseases are purgatives more useful. Constipation, acting locally by the collection of scybala, may seriously displace the pelvic viscera; or, by exerting pressure on the venous plexuses round the uterus and in the broad ligaments, may cause much congestion and discomfort; or, again, acting constitutionally, may dispose to systemic and portal congestion, which injuriously affect the pelvic organs. In many cases of chronic pelvic disease a course of purgatives, such as sulphate of magnesium, cascara, or aloes, with a few doses of calomel, as occasion may require, will greatly relieve the patient.

In certain obscure cases of pseudo-ileus (Olshausen) Malcolm, Tait, Treves, and Lockwood have shown that a speedy evacuation of the bowel may prevent a life being lost from that form of blood-poisoning, which is caused by the invasion of the system by bowel bacilli (*bacterium coli commune*), which, though always present and usually harmless, may become extremely active and virulent in disease, or even on such bruising or over-stimulation of the intestines as may result from an undue manipulation of the bowel during an abdominal section.

In many cases of acute pelvic inflammation it is far better to keep the bowels open daily by means of a simple mixture of cascara and sulphate



of magnesium, than to keep the patient under the influence of opiates; it is certainly better to do this than to alternate the use of opiates with strong forcing purgatives every two or three days.

In suckling women purgatives are apt to affect the child. Castor oil and calomel seem, however, to be exceptions to this rule. Enemata and rectal injections of glycerine are useful alternatives.

*Tonics* of all kinds may find a place in the treatment of pelvic disorders.

Without going so far as Goodell, who says "one cardinal rule in the treatment of all uterine disorders is the internal administration of iron, and of other tonics, unless contra-indicated," there can be no doubt that iron is well borne in nearly all such cases. Iron should be given almost always with purgatives, otherwise it is often inert; and in such cases as anæmia and chlorosis, with scanty or absent catamenia, it should also be combined (Barnes), with arsenic and freshly prepared acetate of ammonia. The perchloride of iron is very useful in cases of a septic nature, as in sapræmia and septicæmia; and even in such cases as peri-uterine inflammations, where the "septic" element is not so obvious. Iron is sometimes ill borne in cases of hypertrophic endometritis, unless the vascularity of the uterus be simultaneously lessened by ergot.

Permanganate of potassium, in doses of three grains (best combined with unguentum kaolin in the form of a pill), is very useful to increase the effect of iron; in cases of anæmia with amenorrhœa it should be given thrice daily for three days, upon the date when menstruation should appear.

Arsenic is valuable especially when leucorrhœa is present in anæmic girls, with a chronic catarrh of vagina or cervix; in them local treatment is not advisable until a fair trial of constitutional treatment has first been made.

Quinine, which has a special tonic action on the uterine muscle, is a useful adjunct; and in cases of debility or irritability of the involuntary muscles of the body it is usefully combined with strychnine, arsenic, and some sedative, such as belladonna, stramonium, or conium.

*Sedatives* must be given with great caution. States for which they may be indicated are often recurrent; and the repeated administration of alcohol, opiates, etc., to women whose nervous system is overwrought or not under due control, especially at the climacteric, leads to continued use, or rather abuse of these agents. All such drugs should be given sparingly, and, if possible, so disguised or given in guarded prescriptions, that patients may not readily obtain a continuous supply.

*Special Gynæcological Drugs.* — There are very few drugs for internal administration which are especially valuable for gynæcological purposes, and all of them are used for other purposes also.

The most important of these are ergot; cannabis indica; viburnum prunifolium; hydrastis; chloride of ammonium; the bromides; a few coal tar derivatives, such as phenacetin; chloride of calcium; mercurial preparations, and some others, such as castor and apiol.

Ergot of rye is used for two main purposes — to encourage uterine contraction and to lessen uterine hæmorrhage. Its main action is on involuntary muscle fibres, causing a more prolonged and more definitely intermittent contraction, and, according to some observers, leading to a true tonic contraction if given in sufficiently continuous or large doses. Thus it is said to act upon the heart; it causes also contraction of the arteries, and heightens arterial pressure. It may also cause some intestinal or vesical irritation, and may have to be given with belladonna to prevent such unpleasant sequences. Owing to its special action on the uterine muscle it is largely employed for the treatment of passive uterine hæmorrhage, or for that due to organic changes, as in uterine fibroids or fungous endometritis, where diminished vascularity tends to lessen growth. It is also given to promote indirectly the absorption of effete products, and at the same time to reduce uterine congestion, by encouraging contraction; it may thus lessen the bulk of the uterus in cases of sub-involution, and in cases of fibroids it may both starve the tumours and favour their extrusion. Ergot is apt to increase the pain of spasmodic dysmenorrhœa, and may therefore have to be omitted just before and at the commencement of a menstrual period: with this occasional interruption ergot may be given continuously for months, or even for years, without deranging the health. Every now and then, however, large doses will, by contraction of the arterioles, give the heart more to do than it is equal to, and it may have to be discontinued. Ergot should be avoided during pregnancy, except in doses of 5 or 10 drops in certain cases of hæmorrhage (usually grumous), where we find on examination that the uterus has lost its normal firmness, its definite outline, and its intermittent contractions. Ergot should not be given during lactation, as it speedily enters the milk and produces infantile colic. Ergot, though usually given by the mouth in the form of the liquid extract, or as ergotin, may, in either of these forms, be subcutaneously injected, — the former deep into a gluteal muscle, the latter hypodermically, — and though somewhat apt to irritate, can usually be tolerated. Ergotinine, in doses of  $\frac{1}{2}$  to  $\frac{1}{3}$  of a grain, is also useful hypodermically, but though less irritating, it is less efficacious, and is also costly. In chronic hæmorrhages, or where given for long periods, ergot should be combined with acids and purgatives; but when given in severe acute hæmorrhage it should be combined with ammonia.

*Hydrastis canadensis.* — The best preparations are the tincture (dose  $\mathfrak{m}\text{xx}$ . to  $\mathfrak{m}\text{lx}$ .) and hydrastine (gr.  $\frac{1}{2}$  to gr. 1). Though occasionally disappointing, this drug has a decided ecbolic action, and if taken regularly will check chronic hæmorrhages not due to serious organic changes. The drug has also a sedative effect which ergot has not.

*Cannabis indica* is usually given in the form of the extract ( $\frac{1}{4}$  to  $\frac{1}{2}$  gr.) or of tannate of cannabin (gr. ij. to gr. x.). It is extremely useful in cases of menorrhagia with pain, acting even better than *hydrastis*; where the pain of dysmenorrhœa is present, as in some cases of fibroids, it acts far better than ergot, even when belladonna is added to the latter.

Indian hemp varies greatly in strength, and should be ordered from one source; it must be remembered that it is one of those drugs which are apt to affect certain women peculiarly, and at first must be given cautiously in small doses. Vertigo is a frequent symptom of an overdose.

*Viburnum prunifolium* is an antispasmodic, relieving painful contraction and cramps both of voluntary and involuntary muscle; it is useful, therefore, to prevent abortion in cases where uterine contraction precedes the death of the fœtus (extract, dose gr. ij. to gr. x.).

A large group of antispasmodics and sedatives may be used in the treatment of uterine colic, but it will suffice here to name the good effect which phenacetin, antipyrin, exalgine, and other coal tar derivatives, as well as apiol and castor, have in the relief of all sorts of pelvic pain, including the pain of dysmenorrhœa, cancer, and neuralgia. Nitroglycerine (gr.  $\frac{1}{100}$ th) also relieves pain, and is especially useful in the last stages of cancer of the uterus, where uræmic symptoms, such as headache, scanty urine, and nausea, may have supervened.

The bromides of potassium and ammonium allay the pain and general restlessness due to increased local tension, as for instance in cases where congestion of the ovary, or rapid growth of a fibroid, causes a painful distension of their enveloping capsules. They also tend to lessen hæmorrhage of a passive type, and are particularly useful when taken so as to anticipate menstruation where menorrhagia is associated with antemenstrual dysmenorrhœa, headache, and nausea.

Chloride of ammonium has also good effect in relieving pelvic congestion, probably by its action on the liver, and is therefore useful in all cases where the vascularity of the pelvis is increased, as in fibroids, subinvolution, chronic metritis, and simple congestion.

Chloride of calcium, in doses of 10 to 20 grains thrice daily for two or three days, answers like a charm in some cases of menorrhagia, where ergot has failed, though the appropriate class of cases is not yet ascertained. It acts (13) by encouraging the ready coagulation of the blood.

Perchloride of mercury, and other preparations of that metal, have some special use in promoting absorption of long-standing inflammatory exudations, such as are found in the chronic metritis of subinvolution, or as persistent thickenings about the pelvic floor, after pelvic inflammation.

**4. Balneo-therapeutics.**—Such a large subject as this can only be very briefly outlined, but the following remarks and table will not be out of place:—

There are certain health resorts and spas, at home and abroad, noted for springs of water which have been found useful in pelvic disorders. Some of the best are here tabled, but it must be remembered that it is often necessary to send a patient to a resort where the water is suitable rather to the constitutional diathesis than to the actual pelvic condition which may be a complication. Thus anæmic patients may be sent to Schwalbach, Nauheim, Leuco, or Strathpeffer; and gouty persons to Wiesbaden, Homburg, Bath, Harrogate, Kissingen, and many others.

Sea-water, again, is a very good substitute where it is not possible to

go to one of the following or other suitable resorts. Sea-water, when pure, is somewhat similar to Woodhall Spa water; it is rich in salines, bromine, and iodine, is a powerful hepatic stimulant and purgative, and can be used internally as well as in the form of baths and douches, in some cases of portal and pelvic congestion, with great advantage.

The following are some of the baths which are especially useful in cases of chronic pelvic congestion, subinvolution, or fibroids, and serve to hasten complete recovery after acute inflammatory attacks, where exudation into the uterine or periuterine tissues has been well marked.

[For a more ample account of Balneology the reader is referred to the article by Dr. Weber in *Syst. of Med.* vol. i.]

TABLE OF BATHS AND HEALTH RESORTS FOR CHRONIC PELVIC DISORDERS

Names of Places and Altitude.	Season.	Character of Water.	Special Uses.
Bex, Switzerland, 1400 ft.	May to Sept.	Saline water, bromo-iodurated	Chronic pelvic exudations. Fibroids.
Carlsbad, Bohemia, 1214 ft.	May to Oct.	Alkaline saline. 120° F. to 170° F.	Chronic pelvic congestions. Gout.
Contrexeville, France, 1000 ft.	June to Sept.	Alkaline effervescing. 55° F.	Where gravel or urinary diseases complicate pelvic disorders.
Franzenbad, Bohemia, 1900 ft.	May to Sept.	Alkaline effervescing and ferruginous	Pelvic congestion with hæmorrhoids.
Kissingen, Bavaria, 600 ft.	June to Sept.	Cold saline	Pelvic congestion with constipation.
Kreuznach, Germany, 350 ft.	May to Oct.	Bromo-iodurated and saline	Subinvolution. Chr. inflammation. Fibroids.
Marienbad, Austria-Hungary, 910 ft.	May to Sept.	Ferruginous mud-baths	Chronic exudations in cellular and peritoneal tissue.
Plombières, France, 1330 ft.	June to Sept.	Ferruginous. 66° F. to 143° F.	Chron. endometritis with anæmia.
Pyrmont, Germany, 410 ft.	May to Sept.	Effervescing, ferruginous, and saline	Chron. catarrh with anæmia.
Royat, France, 1480 ft.	June to Sept.	Alkaline, ferruginous, and arsenical. 45° F. to 95° F.	Pelvic congestion with gout.
Schwalbach, Germany, 955 ft.	May to Oct.	Ferruginous . .	Anæmia with chronic catarrh.
Salzbrunn, Bavaria, 2800 ft.	May to Oct.	Iodine springs . .	Chronic congestion.
Vittel, France, 1000 ft.	June to Sept.	Alkaline effervescing	Congestion with obstinate constipation.
Woodhall, Lincoln,	May to Oct.	Saline bromo-iodurated	Subinvolution. Chronic inflammation. Fibroids.

5. Local Therapeutical Measures. — i. *Heat and Cold.* — (a) *External Applications.* — Cold will excite reflex local contractions in both voluntary



and involuntary muscle. In vigorous persons it increases the exhalation of carbonic acid. The effect of cold externally and suddenly applied is well seen when it is applied to the abdomen to cause uterine contraction in post-partum hæmorrhage; or to the skin of the new-born child to excite diaphragmatic movement. The reflex effect of cold upon distant glandular organs is less well understood; but we know that cold locally applied temporarily checks secretion in all the glands—a check to be followed, in health, by a reactionary period of augmented secretion.

Heat, if moderate, is sedative; but if great, may excite muscular contraction as does extreme cold, producing this effect with less shock to the individual. Hot baths are mainly sedative, relaxing the skin and its glands, dilating peripheral vessels, and thus relieving congestions of internal viscera: they are useful, therefore, in congestive dysmenorrhœa, prolapsed ovary, and the like; and are very soothing to the flushings, the restlessness, and the irritability of the menopause. They also relieve muscular spasm and severe tension, and are therefore found serviceable in spasmodic dysmenorrhœa, and in cases of uterine, tubal, intestinal, hepatic, and renal colic.

Hot foot and sitz baths act somewhat similarly. In the bath, blood is drawn from the internal organs to the surface and to the legs; these baths are therefore useful in relieving pelvic congestion, and in cases where the catamenia have been suddenly arrested by “a chill” with resulting stagnation of the pelvic circulation. After the bath the blood returns more freely to the pelvis, the circulation of which is re-established; and the menstrual flow is thus encouraged to continue. Mustard added to such baths increases these effects.

Poultices and fomentations, as regards both their utility and action, may be considered as local baths. If a sedative effect be required, belladonna or opium may be added to the fomentations; if a stimulating effect, turpentine may be added.

Poultices should be continuous, and should be repeated every three hours, or oftener if need be. If made thick and covered with oiled silk and flannel, and applied in the first instance very hot, they may remain somewhat longer at a suitable heat. If the local relaxation produced by a poultice be not wanted, a pad about a foot square can be made by sewing up some bran in quilted flannel. This can be put into the oven and applied dry, or may be kept hot by a Leiter's coil. By dipping this bran pad in very hot water it becomes a very light and ready poultice.

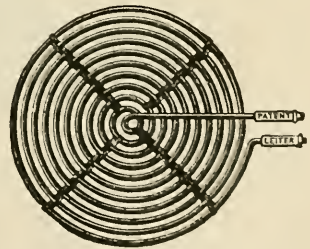

FIG. 52. — Leiter's coils.

Leiter's pliable metal coils (Fig. 52) have now taken the place formerly occupied by Chapman's spinal bags. Chapman showed that the heat or cold of these bags acted upon the spinal and ganglionic nerves going to the vessels. Thus ice-bags applied to the lower dorsal and lumber regions in ar-

rested menstruation, by partially paralysing these vaso-motor nerves, and so causing dilatation of the pelvic vessels, encourage a freer pelvic circulation.

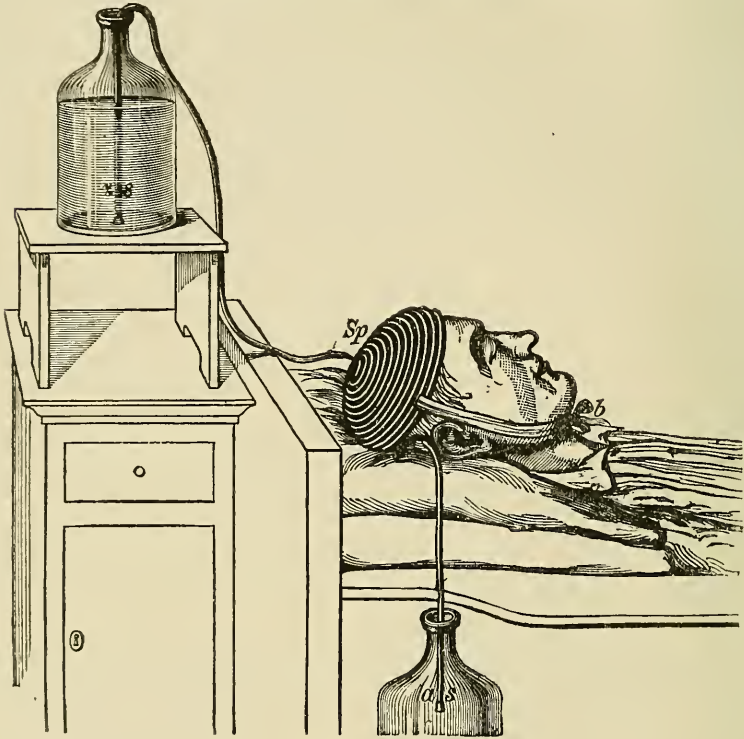

FIG. 53. — Application of Leiter's coils.

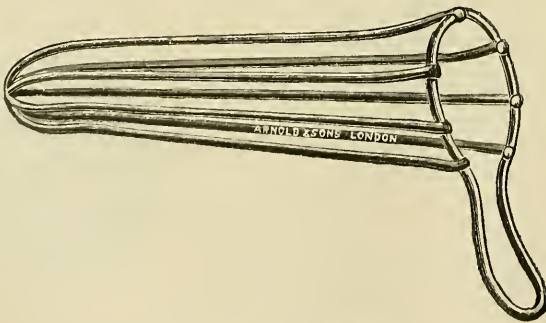

FIG. 54. — Bath speculum.

Hot applications to the same regions are, by analogous action, very useful in checking menorrhagia. Leiter's coils fulfil these objects admirably; and the water can be regulated and kept at any given temperature either

by the addition of ice to the reservoir of water, or by a spirit lamp under it; and cooling can be increased or lessened by the rate at which the continuous stream of water is allowed to pass through the tubules of the coil. The pliability of the coil allows it to be moulded to any part of the body, and if the tubes be made of aluminium their weight is trifling.

For reducing temperature, a coil can be moulded to the back of the head, and iced water allowed to run through it. For rallying a patient suffering from shock, heated coils applied to the feet, on the chest, and under the arms answer admirably. If moist heat be required to imitate a poultice, cloths wrung out of warm water can be wrapped round the hot coil.

(b) *Internal Applications of Heat and Cold.* — Whilst in a bath, water can be made to enter the vagina by means of a grided speculum (Fig. 54). The more usual means, however, is a douche apparatus. In all cases the flow into the vagina should be continuous — from an elevated supply of water, as from a suspended douche-can, or from an elevated syphon arrangement (Fig. 55); not intermittent, as when a hand-ball enema is used. If a douche-can be the vessel employed, the outlet should be slightly above the level of its base, lest imperfectly mixed powders, or other ingredients, should escape in too concentrated a form.

If cleansing alone be needed, two or three pints of water are sufficient; but for relief of local congestion irrigation is employed, and several pints are used for twenty to thirty minutes. The value of this procedure, however, is probably over-estimated.

The vaginal nozzle should be of toughened glass, and capable of being easily cleaned. The patient should lie flat on her back, with the pelvis raised on a bed-bath (Fig. 56), or projecting over the edge of a couch.

For the mere application of heat, all that is necessary beyond these points is that the temperature of the water should be properly regulated. In prolonged douching for relief of congestion, lukewarm water (95° F. to

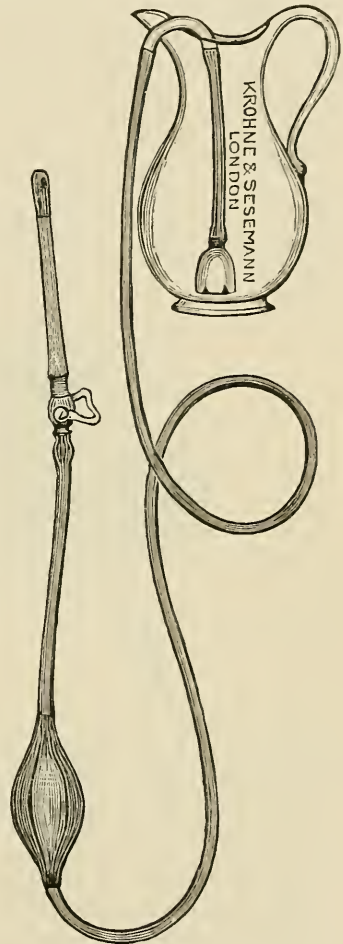

FIG. 55. — Syphon douche.

105° F.) is indicated; but for arrest of hæmorrhage, or the production of muscular or vascular contraction, a temperature of 118° F. is required. Extremely cold water will also check hæmorrhage, though it will not promote coagulation of the blood; it is, however, obviously unsafe to employ it, as it may unduly check secretion, or prevent the menstrual flow from appearing if due. It is also much more trying to the general health of the patient, and water at so low a temperature is not readily obtainable.

It must be remembered, however, that, in addition to the thermal properties of the vaginal douche, it also has a very well-marked mechanical action. This is best obtained by so elevating the douche-can as to make the continuous current of water somewhat forcible, and capable of ballooning the vagina. This action raises the uterus with its appendages

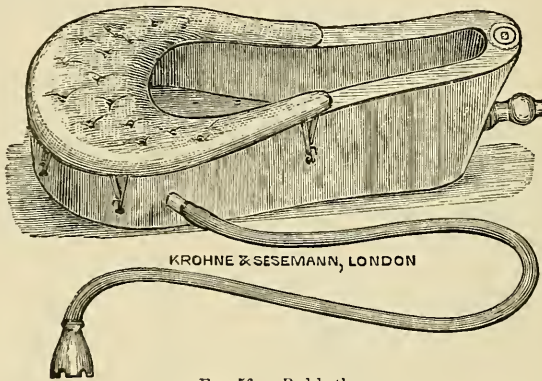

FIG. 56. — Bed-bath.

and the other pelvic contents, empties engorged lymphatic vessels, glands, and distended veins, and gently stretches, and perhaps promotes the absorption of chronic inflammatory thickenings.

This ballooning of the vagina can be increased by further elevation of the reservoir, or by the patient arresting the outflow of the water from the vagina by hand pressure on the vulvar orifice.

By the addition of medicinal agents the douche can be rendered antiseptic, anodyne, astringent, or sedative. These further actions will be discussed later (p. 261).

(ii) *Medicinal agents applied to* (a) the skin; (b) the vulva; (c) the vagina; (d) the uterus.

(a) *The Skin.* — Counter-irritation to the skin may be applied in a variety of ways, by such drugs as cantharides, mustard, turpentine, iodine liniment, croton oil, and others in ordinary use.

They all lessen pain and appear to check the spread of inflammation, and also to promote absorption of inflammatory exudations. These results are probably brought about by influencing the vaso-motor nerves; but, by stimulating the skin, they lead also to its increased vascularity,



and presumably to a relatively diminished vascularity of subjacent tissues. It is clear too that there is some distinct action upon the terminations of the nerve filaments from the spinal cord; and for this reason counter-irritants should be applied over the position where the nerve trunks, which supply the inflamed organs, send branches also to the surface of the skin. These areas, as Dr. Head has shown, are not necessarily at the site of greatest pain, but where the touch of a blunt point like a pin's head detects hyperæsthesia. It is found that these areas are supplied by the posterior root of the same nerve which also sends sensory nerves to the inflamed viscera. Thus the ovary, when inflamed, causes referred pain and cutaneous tenderness along the tenth dorsal area; the nerves going to inflamed Fallopian tubes are particularly associated with the eleventh and twelfth dorsal segments; so also are the nerves supplying the upper parts of the cervical canal and the internal os: the lower part of the cervix is related to the third and fourth sacral areas. Much valuable information on this subject may be found in Dr. Head's paper.

It is difficult, of course, to estimate the curative effect of counter-irritants, in those cases where rest in bed is a coincident factor in the treatment, and wherever possible these two means should be associated.

(b) *Applications to the Vulva.*—The various inflammatory and other morbid states of the vulva are dealt with as are other places in the body, which resemble it in being covered partly by skin, partly by mucous membrane, with a good deal of transitional epithelium at the points of union. Ointments, lotions, fomentations, and baths have each their appropriate usefulness. If the vulva alone be affected, especially in young children, baths form the best means for applying sedative or stimulating lotions.

(c) *Applications to the Vagina.*—Medicaments may be applied to the vagina in many ways. Among them may be mentioned injections, douches, tampons of prepared wool or gauze, pessaries made up with cacao butter or gelatine; or applications, in the form of ointment, powder, or solution, may be made to definite areas of the vagina through a grided or duckbill speculum.

Douches are a very convenient way of applying medicaments to the vagina where only temporary influence is required. If used for antiseptic purposes, perchloride of mercury may be used in the proportion of 1 to 4000 or 2000; or if prolonged use be needed, carbolic acid (1 in 100), or tincture of iodine (ʒj. to pint), or borax or boric acid or izar may be substituted in the same proportion. Condy's fluid and sulphocarbonate of zinc are also useful, and creolin, or lysol (1 in 200) is more suitable before a vaginal operation when it is important that the vagina should be soft and supple; most of the other antiseptics render it temporarily unyielding and contracted. For rendering the vagina absolutely antiseptic more complete measures may be needed (see p. 270). Douches can be made sedative by means of the addition of liq. plumbi subacetatis (ʒij. to Oij.), laudanum, or liq. opii sedativus (ʒj. to Oj.), chloral hydrate (gr. xx. to Oj.), borax or bicarbonate of soda (ʒij. to Oij.), or Condy's

fluid well diluted. Of astringent preparations, alum, sulphate of zinc, and tannin (in the proportion of half a drachm to the pint) are the best.

Medicated pessaries can be used for all purposes. Absorption is slow and imperfect through the vaginal mucous membrane, and at least double the usual dose of a drug should be thus administered. Only those drugs are thus used which are known to have a local effect. They are best combined with gelatine or with cacao butter, the latter being itself very soothing. The drugs most often used as sedatives are cocaoine (gr. ij.), morphia (gr. j.), extract of belladonna (gr. ij.), henbane extract (gr. v.), hemlock extract (gr. v.). Astringent pessaries should be made up with cacao butter; alum and tannin are the agents most used.

If we desire to relieve vaginal congestion, or to encourage secretion from the vagina, a pessary of glycerine (ʒiiss.) combined with gelatine (ʒss.) is very efficacious. This agent has one of its most useful applications as a preliminary to rapid dilatation of the cervix, the nurse being directed to introduce the pessary up to the level of the cervix two hours before the operation. If desired, drugs may be added to these pessaries to make them antiseptic or sedative; and it is in this form that ichthyol, ℥iij. in each pessary, has its most useful sedative and absorbent application. Ichthyol pessaries are also very beneficial in subinvolution associated with endocervicitis and granular erosion.

Tampons may be employed to plug the vagina, or lightly to pack it; but they are sometimes used as a convenient method of applying medicinal preparations to the walls of that passage. For this purpose gauze is easily applied saturated with various ingredients, such as carbolic acid, eucalyptus, iodoform, sal alembroth, salicylic acid, sanitas, or thymol; or plain gauze previously dipped in the desired drug, such, for instance, as a 4 per cent solution of ichthyol and glycerine, may be used. Wool likewise, tied into convenient sizes, may be used, and can be obtained saturated with boracic acid or iodoform, or containing perchloride of mercury, eucalyptus, iodine, carbolic acid, or salicylic acid. Wool tampons can be made with astringents, such as alum or tannin, either mixed throughout the wool or rolled up inside it. Wool tampons steeped in glycerine may be used instead of glycerine pessaries, and are very beneficial where the uterus needs support and depletion at the same time.

If it be desired to elevate the uterus, to keep the cervix forwards or backwards, or merely to rest the uterus after some operation in which it has been much drawn out of position, or in which adhesions to other viscera have been broken down, there is no need to pack the vagina very tightly; but this is very desirable where there is severe uterine hæmorrhage, though it is better to plug the uterine cavity itself, a much more certain hæmostatic procedure.

If the vagina is to be packed for hæmorrhage it should be rendered absolutely antiseptic, and the rectum and bladder should be emptied. The patient should lie in the Sims' position, and a duckbill speculum should be passed. A piece of gauze should be inserted into the cervical canal, and the pouches around the cervix should be firmly packed with antiseptic

gauze; a piece should also be laid over the cervix. Pieces of wool rolled up into cylinders about as large as the first thumb joint should be then passed up and pressed firmly against this roof of gauze, and the vagina completely filled; the strings attached to the wool tampons should be allowed to hang out of the vagina. As a rule they should be left in for twenty-four hours, and it will generally be found that the hæmorrhage has been arrested by coagula in the upper gauze layers.

Ointments containing useful drugs may be conveyed into the vagina by ointment carriers, such as Allingham's or Matthews Duncan's (Fig. 57).



FIG. 57. — Ointment carrier (Matthews Duncan's).

The basis of such ointments should be lanolinated lard.

Direct applications of drugs can be made through a speculum to any affected area of the vagina, and in variety they cover a wide range. Nitrate of silver up to a strength of gr. x. to 3j., or an 8 per cent solution of sulphate of copper, is useful in some inflammatory states; pure carbolic acid, chromic acid, acid nitrate of mercury, bromine dissolved in spirits of wine (1 in 4) are all useful, with appropriate precautions, in cases of new growth or malignant ulceration.

(d) *Applications to the Uterus.*— Medicaments used for the vagina may also be employed for the vaginal portion, but more care is required for intra-uterine applications.

To apply substances to the endocervix it must be exposed in a speculum, such as Neugebauer's (Fig. 58), in a good light; after its lining membrane is wiped free from mucus, the solution or powder should be applied on a probe, such as Playfair's, armed with cotton wool. The substances most used are acidum carbolicum liquefactum, iodised phenol,<sup>1</sup> iodine liniment, iodine paint<sup>2</sup> or Churchill's solution of iodine,<sup>3</sup> liquor ferri perchloridi, and

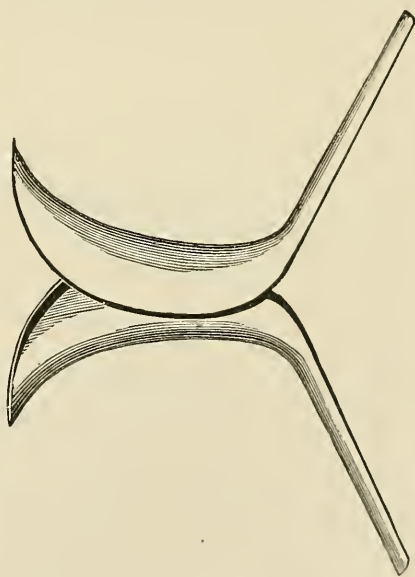

FIG. 58. — Diverging speculum (Neugebauer's).

<sup>1</sup> Iodine 1 part, and liquid carbolic acid 4 parts.

<sup>2</sup> Iodine, iodide of potassium, spirits of wine, and water, equal parts (Samaritan Free Hospital).

<sup>3</sup> Iodine, 78 grains; iodide of potassium, 90 grains; rectified spirits to one ounce.

ichthyol (4 to 10 per cent solution). Another good method is to pour down a Fergusson's speculum a solution which can be encouraged to enter the cervical canal freely by means of an armed probe. One of



FIG. 59.—Playfair's probe.

the best solutions for this purpose is an 8 per cent solution of sulphate of copper.

If there be much congestion, the cervix should be first punctured till it has assumed a light pink colour.

Where the endometrium is extensively inflamed, or is the seat of adenomatous overgrowth, dilatation and curetting become necessary; but there are many milder inflammatory conditions of the endometrium, in which a cure can be obtained by several careful applications of one or other of these or other drugs to the cavity of the uterus. They are best used through a Fergusson's speculum, and should be carried into the uterus on a Playfair's probe<sup>1</sup> suitably curved. The cervix should be exposed and cleansed, and a sound passed to ascertain the exact uterine curve. If this curve be acute, the cervix should be held and drawn down by a tenaculum

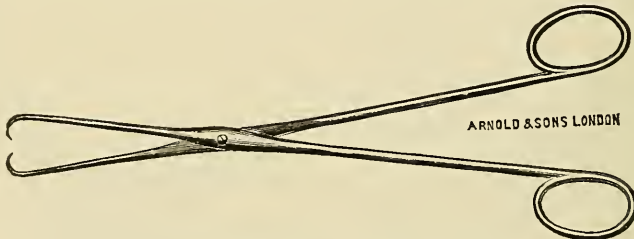

FIG. 60.—Uterine tenaculum forceps (Sims').

(Fig. 60); and if the sound prove any constriction to exist, a few bougies should first be passed: indeed, in any case the application of a powerful medicament may usefully be preceded by a partial dilatation, as uterine colic is thereby prevented and good drainage facilitated. Except in rare cases these proceedings should be taken when the patient is in bed and able to be at rest for some hours. After the application, it is a good plan to pass into the uterus, above the level of the os internum, a thin strip of gauze or lint, soaked in iodine and glycerine, to ensure a watery discharge and free drainage. It should be removed in twelve hours, and an antiseptic douche given. When it is advisable to apply a medicament over the endometrium only, it may be done through a cervical speculum, such as Atthill's (Fig. 61).

<sup>1</sup> The best variety of Playfair's probe is that in Fig. 59. It has not a bulbous end, but tapers slightly, and the wool, though held sufficiently firmly not to come off when the probe is withdrawn, will come off readily enough afterwards without scissors.



Intra-uterine injections should never be used without security of free exit; and in any case no very irritating solution should be injected lest sudden uterine contraction should occur. It must be remembered also that occasionally the Fallopian tubes remain patent as a result of disease, or as part of a general pelvic subinvolution.

**6. Blood-letting.** — Sometimes it is desirable to relieve congestion by the local abstraction of blood. This may be done by applying leeches, by puncturing, scarifying, or dry

cupping; or the result may be arrived at by the extraction of blood-serum, as when blisters are applied, or when vaginal glycerine tampons are introduced. Whatever be the precise method adopted, it should either be carried out at the place actually congested, such as the vulva or cervix uteri, or at a part supplied by blood-vessels, which are either branches of the same main trunk or anastomose freely with its offshoots.

Thus *leeches applied to the perineum* relieve pelvic congestion, by depleting the superior, median, and inferior hæmorrhoidal vessels coming from the common iliac, internal iliac, and pudic arteries respectively; between all of which there is free anastomosis. Relief is, of course, thus afforded to the portal as well as to the general system, as the superior hæmorrhoidal vein belongs to the portal, while the middle and inferior belong to the general venous system. Mr. Marmaduke Sheild has drawn attention to the relief afforded to vesical and pelvic congestion and irritation by the applications of leeches or counter-irritation to the inside of the thighs. This he accounts for partly by vaso-motor influence, but mainly by the depletion of the capillaries fed by the pudic branches of the femoral, relieving thus the areas of congestion by lowering the blood pressure in the branches from the internal pudic of the internal iliac, with which they freely anastomose.

*Leeches to the groin* can be shown to act in a similar manner, and the signal relief thus afforded to swollen ovaries is probably produced by depleting the small twigs from the ovarian artery which pass along the round ligament to the inguinal canal, as well as, more indirectly, through the anastomoses between the superficial and deep epigastric vessels and deep-lying twigs from branches of the internal iliac vessels.

*Leeches to the Cervix.* — Blood may be abstracted from the cervix by the application of leeches, by puncturing, or scarification. Blood thus drawn relieves the whole pelvis. The cervix is mainly supplied from the uterine arteries; but these anastomose so freely with the ovarian and vesical arteries that the relief becomes very general. The vagina should be douched with some warm antiseptic solution, such as borax (ʒij. to Oij.),

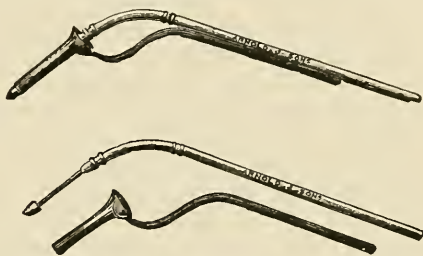

FIG. 61. — Intra-uterine canula (Atthill's); platinum canula, with stilette.

the patient being in bed in a warm room. She should lie on her side whilst a Fergusson's speculum is passed, which should exactly embrace the cervix uteri. The cervix must then be carefully cleansed, and its cavity, especially in parous women, should be occluded by some antiseptic wool. If it be desired to apply the leeches to any particular spot on the vaginal portion, they can be passed down to the cervix in a hollow tube, or held lightly in a pair of forceps; but as a rule it suffices to throw the leeches up the speculum, which is kept well pressed up against the fornices of the vagina. The leeches seize hold where they will, and a large wool tampon is then passed up nearly to the cervix and kept in for ten or fifteen minutes; the wool is then removed, and the leeches, probably then detached, can be easily rolled out. The cervix may then be painted with iodine solution, or an antiseptic douche given. Care should be taken that the leeches do not attach themselves to the vaginal wall, as serious hæmorrhage may follow by perforation of a small vessel. If a leech-bite should thus bleed, pressure applied by means of a vaginal tampon, or the application of strong iodine or perchloride of iron, usually stops it; but if these methods fail, a red hot wire, or the point of a Paquelin's cautery knife at a dull red heat, always succeeds. Where the parts are too tender for a vaginal plug this method should be at once employed.

If it be desired to keep up a little oozing after leeching or puncturing, warm douches may be given, or a glycerine tampon introduced.

*Puncturing and Scarifying the Cervix Uteri.* — Sometimes leeching the cervix appears to be of less permanent good than puncturing; for although more blood is lost by the former method, say two drachms to each leech, there is more suction of blood to the part than where puncturing is employed. In cases of congestion of pathological origin, with marked blueness of the cervix, instantaneous relief is afforded by the abstraction, by puncture, even of two or three drachms — the cervix becoming and remaining pink: thus it becomes evident that the circulation, which was stagnant, is restored. Puncturing is done by exposing the cervix in a speculum, rendering the surface antiseptically clean, and then with a long-handled sharp-pointed knife (Fig. 62) gently stabbing the vaginal aspect



FIG. 62. — Uterine scarifier.

of the cervix. These stabs should be very slight at first, so as to indicate the tendency to bleed; they may then be increased in depth and number till the loss is considered sufficient. Cross cuts (scarifying) may be employed instead of these punctures, or as an addition to them. The subsequent treatment is as for leech-bites. Such an abstraction of blood may be required once a week, for two or three times, the effect being continued by drugs, hot douches, and glycerine pessaries, with rest and diet according to circumstances. If much congestion be present in

cases of endocervicitis, or endometritis, a preliminary puncturing is advisable before applying remedies to the lining membrane.

7. **Operations.—General Measures:** (i) *Antiseptics.*—There is nothing peculiar to gynæcology in the rules of antiseptics, except that it is more difficult to ensure absolute asepsis in the vagina and endocervix on account of the folds and glands there found. The importance of antiseptic vaginal surgery cannot, however, be too strongly insisted upon, for it must be remembered that there is a direct communication between the vulva and the peritoneal cavity, with only partially protective anatomical barriers at the hymen, external and internal os uteri, and uterine cornua. The danger, therefore, of conveying infective or septic products by incautious handling from a lower to a higher level of the genital tract is very evident. Every one has heard of septic inflammation following the use of a sound—doubtless traumatism plus sepsis—and it is, of course, useless to cleanse the sound well if it be allowed to pass through a septic vagina en route to the uterus. The sound should therefore either be passed along an antiseptically clean finger, and through an equally clean vagina, or it should be introduced through a speculum; and, if there be any suspicion of taint, it is safer to pass afterwards a Playfair's probe armed with wool dipped in tincture of iodine or other antiseptic solution. No one nowadays would dream of dilating a uterus except under strict antiseptic precautions; yet similar precautions are rarely thought necessary for the passage of the sound, where precisely identical risks are run. Indeed, the risk of passing a sound may be greater, because drainage may be very incomplete, and any infective material carried up is almost necessarily retained in the womb. Without antiseptics the most trifling operation on the generative organs may end in disaster; with rigid antiseptics it seems possible to do almost anything with impunity.

The subject of antiseptics may be subdivided as follows:—(a) Antiseptics as regards the operator and assistants. (b) Antiseptics as regards instruments and sponges, etc. (c) Antiseptics as regards ligatures, sutures, etc. (d) Antiseptics as regards the patient. (e) Her environment.

(a) *Antiseptics as regards the Operator and his Assistants.*—The operator's (and his assistants') arms should be bared to the elbow, and he should be covered with a clean mackintosh apron reaching from neck to ankles. The hands and arms should be thoroughly washed in two basins with soap and water, especial care being taken of the nails. The skin should then be rinsed with clean sterilised water, and dried by a previously sterilised towel. In most cases all that is further required is to steep the hands for two minutes in a 1 per 1000 solution of corrosive sublimate solution, and allow them to dry; but if the operation be an abdominal one, further precautions are desirable. Thus the hands and arms may be steeped in a saturated (4 per cent) solution of permanganate of potash (the resulting stains may be removed in one minute by a 1 in 20 sulphurous acid solution or a saturated oxalic acid solution), and finally in the corrosive sublimate solution as above. Sanitas or turpentine, poured on



the hands after an operation, render them quite free from any offensive odour. Cold water removes blood from skin better than hot.

(b) *Antisepsis as regards Instruments, Sponges, etc.* — Instruments should be placed in boiling water or steamed (Fig. 63) before as well as after the operation, and then laid in a tray, similarly prepared, containing hot carbolic solution, 1 in 40 to 1 in 20. Both corrosive sublimate and iodine solution corrode steel and plated instruments, and Condy's fluid, lysol, and creolin solution obscure the transparency of the water. All instruments should either be capable of being taken to pieces and thus easily cleaned, or should be made out of a single piece of metal, handles of wood or bone being avoided. During the operation all instruments should either be placed again in the tray of carbolic, or they may be laid upon a clean

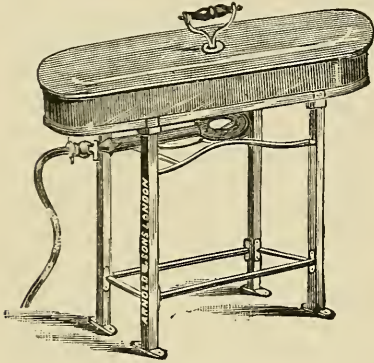

FIG. 63. — Steriliser for instruments (Harrison Cripps).

towel, and dipped in the carbolic solution before being again used. Extra care must be taken to clean the eyes of needles and the rough surfaces and joints of needle-holders, artery and other forceps, scissors, and the like. It is important that instruments used at an operation should not be allowed to dry before being cleaned.

In most operations sponges may be superseded by the use of antiseptic wool carried on holders, or made into pads or pledgets. These pads are best made by having gauze sewn round them; they should then be rendered antiseptic by boiling for two hours, and kept in a solution of carbolic acid, 1 in 20, or in sublimate solution, 1 in 1000. Before use they are wrung dry, and may be employed, after careful recleansing, throughout the operation. If sponges be used they should be prepared as follows: — Immediately after use they should be thoroughly cleansed till the water remains untinted, and then soaked for from two to four hours in four pints of warm water (for, say, 25 sponges), in which a handful of washing soda has been dissolved. The sponges are then removed and well washed in three or four waters to remove sliminess, and finally soaked for twenty-four hours in a covered bowl, containing a 1 in 500 sulphurous acid solution, which bleaches them. After being well dried they are wrapped in a sterilised towel, or put away in a large hermetically closed glass jar (Fig. 64), with a small quantity of

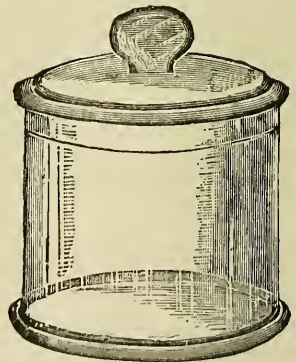

FIG. 64. — Glass jar for sponges, wool-pads, etc.



alcohol. For some hours before the operation they should be soaked in a 1 in 20 solution of carbolic acid, which should be diluted with equal parts of boiling water at the time of the operation. The nurse who has charge of the sponges should squeeze them thoroughly before handing them to the assistant operator, and during the operation they should be thoroughly rinsed in hot carbolic solution till free from all blood, etc., and then kept in the 1 in 40 carbolic solution till required for further use.

(c) *Antisepsis as regards Ligatures and Sutures.*—Silk when used for ligatures may either be left long, as in vaginal hysterectomy, to come away in from five to twenty days; or may be cut short and so gradually destroyed by the action of leucocytes after a much longer period, — sixty-four days, according to Thomson of Dorpat. If in the peritoneum, they may require, according to Ballance and Edmunds, at least 500 days for their complete absorption.

The best silk for internal ligation or suturing is China twist; though when it gets dry, as it would if used externally, it tends to kink and coil. Floss silk is more apt to slip when being knotted. Silk must be used sufficiently thick to be firmly tied, but must not be too thick to make a deep groove in the part ligatured. It will also be noted that the thinner the silk the more rapidly does it come away or get absorbed.

In using silk ligatures be sure that they have been efficiently sterilised (Fig. 65), and that they remain antiseptic. As boiling perceptibly weakens silk, after being so treated its strength should be always tested before use. Previous to the operation the silk should be well

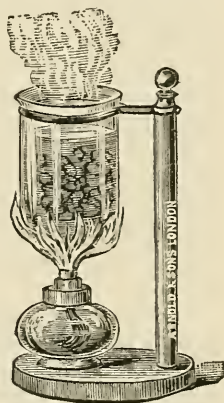

FIG. 65. — Steriliser for ligatures.

soaked in a 1 per 1000 corrosive sublimate solution, or in a 1 in 20 carbolic acid solution. When not being used it may be wound on glass reels, and kept in airtight glass bottles (Fig. 66).

Every operator has his own way of preparing catgut and rendering it antiseptic. It seems best to soak it in ether

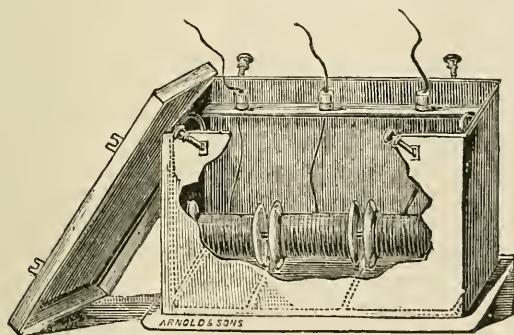

FIG. 66. — Catgut or silk sterilised in alcohol.

(Pozzi) to remove any grease, and so allow antiseptics to enter freely among its fibres. Then it may be immersed for one hour in a 1 per 1000 solution of corrosive sublimate, and afterwards rolled on glass plates

or cylinders, and steeped in oleum ligni juniperi for a week, to render it supple and flexible; it should then be kept in a mixture of rectified spirit and juniper oil (10 per cent) in an air-tight bottle till wanted. Immediately before being used it should be immersed in the sublimate solution. Catgut is usually absorbed in about ten days.

Silkworm gut is the most imperishable organic ligature known. It is bought in bunches of 50 or 100 strands, the curly ends of which should be cut off, and the straight intervening portions only used. These should be rendered antiseptic by boiling in a 1 in 20 carbolic acid solution, and should then be kept in long glass bottles, containing absolute alcohol, for preservation. Before being used they should be placed in boiling water to make them supple and pliable.

Silver wire should be kept in a 1 in 20 carbolic acid solution, and before being used should be well polished by friction with wash-leather, then boiled, and replaced in the carbolic solution.

Glass drainage tubes should be boiled in sublimate or carbolic acid solution, and india-rubber tubing may be similarly treated for not more than fifteen minutes, being subsequently kept rolled up in antiseptic gauze, or in stoppered bottles containing weak sublimate or carbolic solution. To preserve india-rubber tubing, oil of all sorts, iodine, and a temperature higher than 120° C. should be avoided.

(d) *Antisepsis as regards the Patient.*—Although the patient is prepared for some days previous to the operation by baths, yet much remains to be done before the skin and other parts are really aseptic.

a. *Before Abdominal Section.*—There is probably far more danger to the patient from infection from her own skin, sweat glands, and so forth, than from the germs which may and do enter from the atmosphere. The glands open so freely on its surface that it is doubtful whether it be possible to purify the skin perfectly. The permanganate and oxalic acid method is one of the best methods for aiming at perfection.

After freely washing the skin, and especially the umbilicus, with soap and water, and subsequently with ether, to remove any fatty material, the surfaces should be washed several times with strong permanganate of potash solution, which stains the skin of a deep mahogany colour. This discoloration can be removed by a 1 in 20 sulphurous acid solution, by a concentrated oxalic acid solution, or to a less perfect extent by sanitas or turpentine. This should be done some hours before the operation, and the abdomen should then be covered by a wool or gauze pad wrung out of a 1 in 40 carbolic acid solution; when this is removed immediately before the operation the skin should be carefully washed with a 1 in 1000 sublimate solution.

β. *Before operations on the perineum or per vaginam,* the nurse will douche the vagina twice daily for two or three days with hot water containing tincture of iodine (1 in 150), or carbolic acid (1 in 60), or corrosive sublimate (1 in 2000); and after carefully washing the external genitals and perineum, will foment them with the same sublimate solution. If so directed, she will also shave the vulva and peri-

neum before the operation. Three hours before the operation the last toilet should be effected, by douching the vagina and washing the genitals either with sublimate, or as indicated for abdominal section; and when so instructed she should clean the vagina more thoroughly by manipulation and swabbing, and pack it lightly with antiseptic gauze.

At the operation the gauze should be removed, and the vagina vigorously douched and well swabbed out with cotton-wool pads saturated with 1 per 1000 sublimate solution; the cervical cavity should be similarly treated.

In some vaginal operations a continuous stream of antiseptic (carbolic or iodine) lotion may be kept running over the parts, either by using instruments hollowed out like a flushing curette, or by special arrangement. After the operation a douche should, as a rule, be given, antiseptic dry pads applied to the perineum, and possibly a vaginal antiseptic gauze tampon also employed. Subsequent contamination by urine and fæces must be prevented for some days by catheterisation and careful cleanliness.

(e) *The Surroundings of the Patient.* — From the antiseptic point of view the room in which the operation is to be performed should be scrupulously clean; and as a rule, whatever the nature of the operation, it is desirable to operate in a room apart from the ward in which the patient has previously been sleeping. After abdominal section the patient should, if possible, be in a room isolated from other wards for some days.

The operation room should be well lighted by windows, and should also be provided with electric light. The walls of the room and the ceiling should be distempered, and its floor made of concrete or polished wood-blocks. For abdominal operations a room on the top floor, with a skylight, is very advantageous. The furniture should be scanty, and made of glass and enamelled iron, so as to be easily cleaned.

If a case have shown any evidence of a septic process the ward must be thoroughly disinfected, before another case is admitted, by having the floor and furniture washed with sublimate lotion, by having sulphur burnt in the room with all its outlets closed, and by having its walls and ceilings freshly distempered. The bed-furniture should be sterilised, and the mattress should be destroyed.

It is almost superfluous to add that the drainage of the house must be absolutely perfect, and that the water-supply, both hot and cold, must be pure and ample.

(ii) *Preparation of the Patient, apart from Antiseptics.* — When it is known that a patient is to be operated upon in a few days, everything should be done to promote the functional activity of her organs so that she may better withstand the ordeal of the operation, and perhaps avoid a tedious convalescence.

Her diet should be light and nutritious, with plenty of non-alcoholic fluid to encourage the skin and kidneys to act freely. Warm baths at bedtime, with free use of soft soap and a brisk towelling, should be ordered, and the bowels should be regulated by some such mild pill as



pil. coloc. cum hyoseyam. gr. iv., pil. hydrarg. gr. j., at bedtime, followed by a seidlitz powder in the morning. On the morning of the operation the larger bowel should be emptied by an enema; and if it be evident that the rectum will, after all, be active during the operation, it may be advisable to pass a suppository of pil. plumbi cum opio, gr. v., two hours beforehand.

Before the operation a good night's sleep should, if necessary, be ensured by means of a harmless drug, such as 30 or 45 grains of bromide of ammonium.

No solid food should be administered for at least eight hours before the operation, though some diluted milk, or egg and milk, or peptonised raw beef juice may be given three hours beforehand.

Immediately before the operation the patient should either pass water, or have the catheter passed by the nurse.

At the time of the operation the patient should be warmly but loosely clothed, the exact details varying necessarily with the nature of the operation.

The bed into which the patient will be put after the operation should be warmed by a hot bottle, which should lie at the foot; and an extra blanket should be provided till the skin acts freely.

(iii) *Anæsthesia, Local and General.*—(a) *Local Anæsthesia.*—Cocaine is the agent mostly used as a local anæsthetic, both for the relief of severe pain, pruritus, or other form of local hyperæsthesia, and also prior to operation, where, for any reason, general anæsthesia is contra-indicated.

Cocaine (10 to 20 per cent) may be painted on the skin or mucous membrane, or may be rubbed on as a lanolinated ointment; after a few minutes the tissue loses all sense of contact, and becomes "wooden," as the patient generally describes it. Minor operations, such as opening a superficial abscess, or cutting or burning off a wart or a mole, can then be painlessly performed; but if the operation involve deeper incisions, cocaine should be injected hypodermically, or better still, both endermically and hypodermically. To do this, three or four drops of a 2 or even a 1 per cent solution should be used for injection in several places, at distances of slightly over an inch—half an inch radius from each puncture being the zone of absolute anæsthesia produced by such an injection. This anæsthesia is produced in three minutes, and lasts about twenty-five minutes, and provided not more than twenty drops are used at one time, the cocaine is not likely to produce any syncope or other ill effects. Schleich finds that a .02 per cent solution produces anæsthesia after injection, and even distilled water has some anæsthetic effect.

After such an injection of cocaine, operations like trachelorrhaphy, perineorrhaphy, excision of a retention-cyst of Bartholini's gland, or burning off a vascular urethral caruncle may be performed without suffering. It has been asserted, however, that union is often less complete, and repair less rapid, after operation performed with locally induced anæsthesia.

If a caruncle be present, anæsthesia may be desired before cathe-



terisation, and an ointment (8 per cent) may then be gently applied ten minutes beforehand. A similar ointment may be useful in cases of vaginismus or dyspareunia from a local hyperæsthesia, coitus being thus rendered possible. For this purpose, as also for the relief of pruritus, as in kraurosis vulvæ, its use is, as a rule, but a temporary expedient, operative measures being generally needed to effect a cure.

(b) *General Anæsthesia.* — The choice of the anæsthetic is a subject which should not be solely in the hands either of the operator or of the anæsthetist, but the operator should state which anæsthetic he prefers. If the anæsthetist, after noting the type of patient, and listening to the heart and lungs, be satisfied that that particular anæsthetic is not contra-indicated, he will acquiesce; if, however, he consider another form of anæsthesia to be more suitable for the particular patient, a friendly consultation would no doubt lead to the adoption of his advice. Some operators pin their faith to a certain form of anæsthesia as the best for

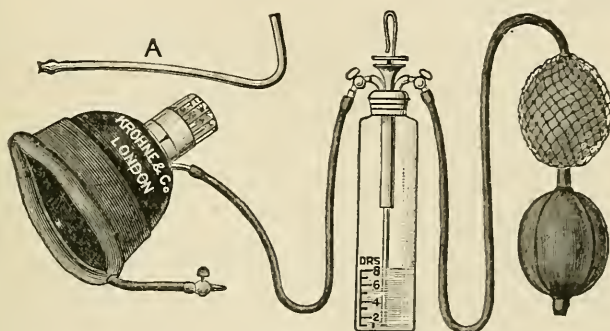

FIG. 67. — Junker's inhaler.

certain operations; but inasmuch as patients vary greatly, the choice must ultimately be made after a consideration of the patient's state, and as the responsibility finally rests with the anæsthetist, it is right that he should be always consulted and his views upheld.

Although much depends on the skill of the administrator, it is probably true that there is more bleeding during ether anæsthesia, and thus, *ceteris paribus*, such operations as perineorrhaphy or vesico-vaginal fistula are easier to perform under chloroform or A. C. E. mixture; sickness is usually more marked after ether, and spasmodic, laboured, or jerky breathing is apt to be present during its administration: for this reason many prefer chloroform for abdominal operations, especially when administered by means of a Junker's inhaler (Fig. 67), but it is fair to say that in the administration of ether by a few anæsthetists these objections are not experienced. Ether should not be used where the abdomen is much distended, or where from other, especially pulmonary conditions, the respiration is laboured. In operations requiring very deep anæsthesia — as in rapid dilatation of the cervix uteri for digital exploration of the uterine cavity — there is no doubt that ether is safer

than chloroform, as it can be "pushed" to a further degree without risk.

After loss of large quantities of blood ether is safer than chloroform.

The scope of this work forbids further reference to the details of the administration of the various anæsthetics.

**8. Therapeutical Operations.**—(i) *Dilatation of the Uterus.*—This operation was introduced by Simpson in 1844, and may be required for various purposes. Dilatation may be complete so as to admit the finger, or merely partial, to facilitate curetting or intra-uterine medication.

Complete dilatation is mainly effected for diagnosis by digital exploration, or for treatment of some condition otherwise diagnosed. It is most frequently employed for the purpose of discovering the cause of an intra-uterine hæmorrhage; and the dilatation must, for that object, be sufficient to admit the introduction of the little, or if need be, of the index finger of the operator.

Partial dilatation is practised for the treatment of some cases of dysmenorrhœa and sterility; or prior to the application of some caustic or counter-irritant to the endometrium; or for the purpose of curetting in cases of hæmorrhage or chronic purulent endometritis, where the uterus is not much enlarged and digital exploration not needed.

In all cases, however, where a diagnosis cannot be made by the examinations of portions of the endometrium detached by the curette or other instrument, or where polypus, carcinoma, or other disease, cannot be excluded by other evidences, it is far wiser to make sure of the nature of the case by dilating so as to admit the finger.

Both degrees of dilatation should preferably be performed immediately after the cessation of a period; then the cervix is softest, and is also somewhat patent. This softness (p. 281) and relaxation are greatly increased by the introduction of a glycerine tampon two hours beforehand by the nurse; and dilatation becomes still more easy if the physician insert into the cervix, as described hereafter, a piece of gauze saturated with glycerine and iodoform about six hours before the operation.

Methods of dilatation:—

A. Gradual dilatation: *a.* By antiseptic wool or gauze. *β.* By tents.

B. Rapid dilatation: *a.* By graduated bougies. *β.* By two or three-bladed dilators. *γ.* By miscellaneous methods.

C. Combined gradual and rapid methods.

D. Dilatation with incision.

A. Gradual Dilatation:—*a.* By Antiseptic Wool or Gauze.—This method was introduced by Vulliet in 1886, and is easy of execution; if antiseptics are rigorously used, and suitable cases selected, no danger should arise.

The vagina and vulva should be previously rendered antiseptic by douching and washing, and the vagina temporarily distended with an iodoform gauze tampon. The cervix should be exposed by a Sims' or by a diverging speculum, such as Griffin's (Fig. 68), Cusco's (Fig. 69), or Neugebauer's (Fig. 58, p. 263), and the anterior lip should be seized by a

volsella and held steady at a somewhat lower level than normal. The endocervix should then be cleansed, and the direction of the uterine canal

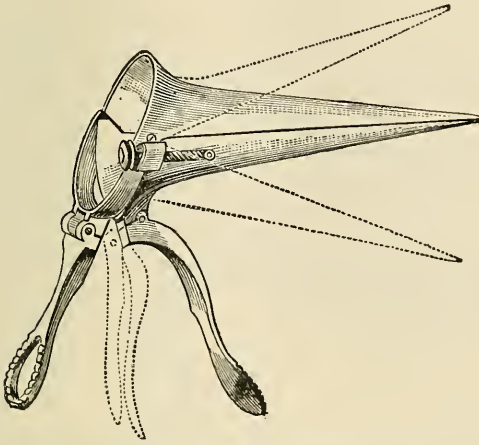

FIG. 68. — Griffin's speculum.

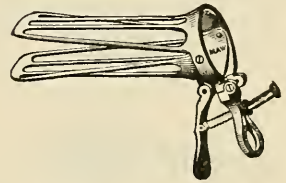

FIG. 69. — Cusco's speculum.

ascertained by a sound; if the os interum be found to be small, a few bougies may be passed. A strip of gauze, a quarter to one inch wide (according to the estimated size of the canal), is then dipped in carbolised or iodised glycerine, and is introduced by doubling it over the end of a uterine gauze applicator (Fig. 70). This instrument should taper some-



FIG. 70. — Gauze applicator (whalebone).

what towards the end, which should be blunt-pointed, and not so fine as to penetrate the gauze. Gauze may also be introduced on long, narrow-bladed forceps (Fig. 71).



FIG. 71. — Forceps to introduce gauze.

After the cervix has been completely or even partially dilated, some operators prefer to tampon its cavity through a cervical speculum (Fig. 72). The gauze should be carried up to the fundus and the probe withdrawn, and more gauze similarly introduced, till the cavity is somewhat tightly

packed. Vulliet preferred to dilate by wool tampons, varying in size from a pea to an almond, rendered antiseptic by dipping in a 10 per cent ethereal solution of iodoform.

Whether gauze or wool have been used it is withdrawn after twenty-four hours, and the cavity carefully cleansed with sublimate swabs. Fresh gauze is then similarly introduced, and, after the third introduction, the cervix will be so softened and dilated as to admit the finger.

The advantage of this method is that it is nearly painless, but unless great care be taken not to injure the endometrium, it is certainly not free from the risk of septic absorption. As a preliminary accelerant of rapid dilatation it is excellent, but even then great care has to be taken to avoid rough introduction of the gauze. To lessen this risk of septic absorption through lesions accidentally made, gauze should never be thus used if the uterine discharges be offensive.

If it be desired to keep the uterus patent after either rapid or slow



FIG. 72. — Cervical speculum (Bantock's).

dilatation, — as, for instance, when it is hoped to obtain the extrusion of a submucous fibroid whose capsule has been incised, — continuous packing of the endometrium will usually ensure the safety of the patient in the frequent case of danger from sloughing of the fibroid. Such packing will further dilate the uterus and render any subsequent manipulations easier.

In some cases of chronic endometritis a partial dilatation and drainage by gauze, with the application of iodine liniment or paint twice weekly whilst drainage is continued, will often cure the condition in a fortnight, the patient meanwhile keeping to her room. Curetting is, however, in most cases far preferable.

*β.* Gradual Dilatation by Tents. — According to More Madden sponge tents were invented by Phillip Barrow in 1539; but the method was so far forgotten that when Sir James Simpson revived their use, in 1844, he stated that “intra-uterine disease was generally considered beyond the pale of any certain means of detection or possibility of removal.”

The tents mostly used are laminaria (introduced by C. F. Sloan of Ayr in 1862), sponge, and tupelo. Gentian root and decalcified ivory are also used by Porak. Laminaria tents, as sold by instrument makers, are unreliable as regards antiseptics; and it would be worth while for any gynæcologist who uses them much to collect and prepare his own, an easy undertaking. Sponge tents are even more difficult to get antiseptically clean. The results of using tents not absolutely aseptic are most disastrous, and have caused many a death; in the pre-



antiseptic days, acute metritis, salpingitis, peri- and para-metritis and septic fever were frequent consequences.

Laminaria and tupelo tents should be steeped in a saturated solution of alcohol and corrosive sublimate for two or three hours, and then allowed to dry before being used; sponge tents may be dipped in an ethereal solution of iodoform (10 per cent), and then dried by swinging them round by the attached string.

Tents are mainly used as a preparatory step to rapid dilatation; but they are still used sometimes for completing dilatation, and must then be repeatedly introduced till the finger can be inserted. I have not used a tent for several years, as I find rapid dilatation answers all purposes when

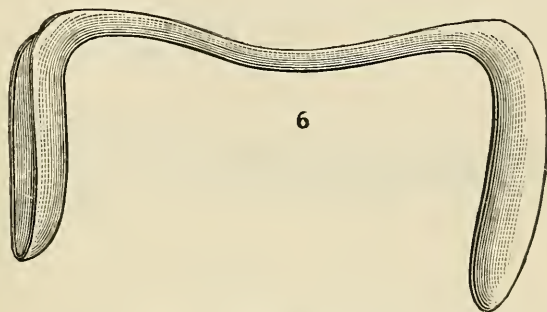

FIG. 73.— Duckbill speculum (Sims').

used with the aids described on pages 280–1, but, as it is evident that tents are still frequently used, full details of their introduction are here given.

After the tents and the vagina have been prepared, and the patient put into the Sims or lithotomy position, a duckbill speculum (Fig. 73) is introduced, and the cervix somewhat lowered by a sharp hook, so as to fix the uterus and straighten its canal. The actual length and curve of the cavity is then ascertained by the sound, and the size of the tent which can probably be introduced is roughly gauged. A laminaria tent can be curved by holding it over a spirit lamp till hot. The cervix should then be cleansed with sublimate solution, and the tent passed either on a

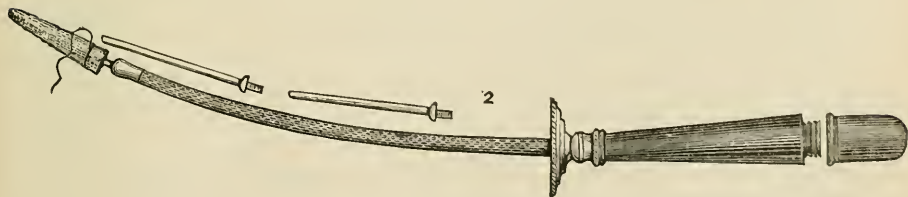

FIG. 74.— Barnes' tent introducer.

pointed introducer provided with a canula, such as Barnes' (Fig. 74), or held in a suitable pair of forceps, such as Chambers' (Fig. 75). It is a good plan to dip the tent into pure liquid carbolic acid before inserting it.

As large a tent, or as many small ones, as can be passed beyond the os internum should be inserted at once. The ends should slightly project into the vagina. A vaginal antiseptic tampon soaked in glycerine should then be inserted. The tents should be left in from eight to twelve hours, especially the hollow laminaria ones, as they do not readily dilate to their full extent at the os internum, where there is greatest resistance. To extract a tent, all that is necessary is to draw upon the string attached to the vaginal end; but if the tent has not dilated well at the level of the os internum, forceps must be used to pull and lever it out, whilst counter-pressure is exerted upon the cervix by the finger.

To admit the exploring finger into the uterus, one, or often two repetitions have to be made. This should only be done after careful antiseptic cleansing both of the vagina and uterine cavity; and then as many fresh tents as can be introduced should be simultaneously inserted.



FIG. 75.—Chambers' tent introducing forceps.

If only a slight further dilatation be necessary, and rapid dilatation be not available, a tupelo tent is better than another series of laminaria, as it dilates more rapidly and more evenly, can be obtained of larger size, and be more efficiently rendered antiseptic. By this time, especially if a third series of tents have been introduced, the temperature may have risen, the patient will be irritable and restless and sometimes nauseated, and not in the best condition to undergo a prolonged examination for the purpose of treating whatever conditions may be found.

In the old days, when the uterus was always dilated with tents, it was not often that any condition was found which required, or at all events was treated by curetting; this is to be explained by the fact that the prolonged pressure of three series of tents, with the application of the intra-uterine counter-irritants subsequently used, would destroy any of the more ordinary hypertrophic fungosities found in so-called "fungous endometritis," and would, if no accidents followed, tend to promote absorption of inflammatory exudations in the parenchyma of the organ. In curetting we have now, however, a much more rapid and effectual method of dealing with these conditions.

Tents should never be used if the uterine discharges are offensive, as the absorption of pent-up putrescent secretions may lead both to local septic inflammation and to a general septicæmia; and, even recently, deaths have been described as having occurred under these conditions. I refer to such cases as cancer of the body of the uterus, sloughing polypus, and even to some cases of fungous endometritis in which the polypoidal

villous processes of gland tissue have either become ulcerated or have superficially sloughed. No tent should ever be used twice.

It must be remembered that the danger of sepsis is not over when the tents have been removed, as, especially with sponge tents, small pieces are apt to remain in the folds of the lining membrane, and will there decompose and cause a local absorption. It is therefore most important that after the withdrawal of tents some strong antiseptic should be carried up into the uterine cavity, such, for instance, as iodine liniment or iodised phenol; and that drainage should, for twenty-four hours, be maintained by passing up into the uterus a thin strip of iodoform gauze soaked in iodised glycerine.

Every now and again it is found that the effect of the introduction of a tent upon the nervous system is considerable; the patient becomes extremely restless, or vomits incessantly, or the temperature rises immediately, or at all events too soon for it to have a septic origin; a few cases of convulsions have been described, and one or two of tetanus. In one case, treated by myself, the temperature rose to 107° F. within thirty minutes of the insertion of the tent; but under the influence of a hypodermic injection of morphia it gradually fell, and by the next morning, on removal of the tent, it was 99° F.; the patient recovered without further trouble. Bromide of potassium is very useful to control this hyperæsthesia and excitement.

B. Rapid Dilatation. — Dilatation by tents, except as a preliminary step, having now been almost universally given up, all the exploratory and therapeutical dilatations are performed either entirely, or in the main, by one or other of the rapid methods. Whereas it used to take from twenty-four to forty-eight hours to dilate the uterus sufficiently to admit the exploring finger, it is now done with far less risk in from twenty to sixty minutes.

Indications for Rapid Dilatation. — Rapid dilatation may have to be done for the treatment of some forms of dysmenorrhœa, as for instance in some cases of the spasmodic or of the obstructive type, and especially in cases of membranous dysmenorrhœa; as a preliminary step to a thorough application of some medicament to the endometrium, or antecedent to a subsequent curettage; or in some of those rare cases where, according to Schultze, it is advisable to dilate the uterus sufficiently to admit the finger, with a view to breaking down retro-uterine adhesions by manipulation, and so to perform "intra-uterine reposition." The main object of rapid dilatation, however, is to enable the finger to be introduced for the purpose of making a diagnosis of the intra-uterine condition in cases of uterine hæmorrhage, where, in the absence of any constitutional cause or obvious local extra-uterine disease, a further examination is indicated.

Assuming, then, that a woman comes for treatment, one of whose chief symptoms is menorrhagia or metrorrhagia, inquiries would be made as to any constitutional cause, and a vaginal examination would be made, unless contra-indicated by virginity or youth. In all cases of hæmorrhage after the menopause, or even in cases of severe hæmorrhage before that

time of life, a vaginal examination should be insisted upon to make the diagnosis sure. Possibly some obvious cause of hæmorrhage would thus be discovered, such as cancer or adenoma of the cervix or vagina, adhesive ulcerative vaginitis, severe erosion of the vaginal portion, ulceration from foreign bodies, an extruding fibroid, a cervical mucous polypus, ulcerating proclitella, or inversion of the uterus. The possibility of a molar pregnancy, a threatened, incomplete, or missed abortion, or the existence of a mole or an endometritis of the gravid uterus, must not be overlooked.

A bimanual examination would further serve to limit the diagnosis, when the uterus might be found uniformly enlarged by subinvolution, or irregularly so by intramural fibroid; or some tubal or other perimetric disease might be found to account for the hæmorrhage. If none of these obvious causes were discovered the sound might be passed, whereby the size and shape, and any considerable roughness and vascularity of the endometrium would be discovered. If the uterus be not enlarged constitutional treatment may be tried; or if an ordinary endometritis be diagnosed in a small uterus, a partial dilatation, prior to the use of some counter-irritant, may be effected without anæsthesia, or after the local application of a 10 per cent solution of cocaine. Even if the uterus be irregularly enlarged, and intra-mural fibroids be diagnosed, it must not be assumed that the hæmorrhage, which is probably the main symptom, is to be dealt with by a serious operation like oophorectomy or hysterectomy, for, as I (25) have elsewhere shown — in a series of consecutive cases dilated for hæmorrhage — 88 per cent of the cases of fibroid uterus thus treated contained a removable cause; that is, they were found complicated with fungous endometritis, polypus, or the two combined, and were thus capable of immediate relief, so far, at least, as the immediate symptom of hæmorrhage was concerned. By this means the patient would often be steered safely over the menopause.

Many cases are now on record, and others are within the knowledge of all gynæcologists, where hæmorrhage has persisted after oophorectomy, and has been subsequently cured by the removal of an intra-uterine polypus after exploratory dilatation.

**Aids to Rapid Dilatation.** — There are many uteri which are difficult to dilate sufficiently to admit the finger, and it is impossible to decide beforehand which cases will prove so resistant. It used to be said that if it were impossible to dilate a cervix, this was a fair proof that it was affected by malignant disease. As a rule a cervix is only materially resistant if there be an intramural fibroid involving part of its circumference, and also in some nulliparous women, but only twice in my experience has this been sufficient to prevent digital exploration. There are aids to dilatation, rendering it easier, quicker, and less dangerous, which it is desirable to emphasise; for it is rare to find that anything has been done to prepare the patient before the actual operation, except perhaps from the antiseptic point of view. First of all, it is infinitely easier to dilate a cervix if the day following the cessation of a period is chosen. The tissues are softer, and the cervix is somewhat patent. This was first



noted by Dr. C. H. F. Routh in 1864; recently Dr. Braithwaite has drawn special attention to this fact, and Dr. Herman has shown that this relaxation is most marked on the third and fourth days of ordinary periods; but it is better to await the cessation of the period before attempting dilatation. Secondly, the cervical glands should be encouraged to secrete, for, as Dr. Champneys has said, dilatation is physiological, and the cervix has to be induced to yield. When it yields it also secretes, as in pregnancy and labour. When the cervix is moist it is dilatable; when dry it is rigid; and, in this latter condition, any attempt at rapid dilatation is generally a failure, and might cause extensive tearing. Many writers consider the best way to overcome this rigidity is by preliminary partial dilatation by tents; but it is evident that there may be danger in this also, as well as several hours' discomfort to the patient.

The cervix can be induced to secrete freely by inserting into the vagina, two or three hours before the operation, a wool tampon soaked in glycerine, or less effectually by a gelatine and glycerine pessary. The effect of the glycerine is enhanced by the addition of a little cocaine, which serves to relax local spasm, as it does in rigid cervix in the first stage of labour. In either case the glycerine should be applied close up to the external os uteri. Secretion is further helped by giving a warm vaginal douche of borax or creolin solution before introducing the glycerine tampon.

If unusual difficulty be anticipated, owing to nulliparity, advanced age, or the presence of fibroids, additional help is afforded by passing into the cervical cavity, and if possible through the os internum, some gauze saturated with glycerine and iodoform. This may be introduced from six to twelve hours before the operation, which it greatly facilitates by relaxing the muscular fibres, and partly dilating the canal. As has been stated this preliminary gauze packing should not be adopted when there is an offensive discharge. These "aids" practically obviate the need for a preliminary dilatation by tents in all but very exceptional cases.

Methods of Rapid Dilatation. — Assuming, however, that rapid dilatation has been decided upon for the purpose of making a diagnosis of the intra-uterine condition to which is due the hæmorrhagic, purulent, and possibly offensive discharge, there are several ways by which this can be effected, namely: i. By graduated bougies; ii. By two, three, or four bladed dilators with or without attached screws; iii. By miscellaneous instruments.

a. Rapid Dilatation by Graduated Bougies. — In England dilatation by bougies is preferred; and when carefully and antiseptically conducted, it is free from risk, sufficiently speedy in its performance, and effectual in its results. Hegar's bougies were first introduced to the profession in 1881, but were not in general use in this country till eight or ten years later: when amongst others Drs. Lewers and Phillips drew special attention to their value. Hegar's original dilators were rather short, and made of polished wood or ebony; they consequently gave rise to a good

deal of friction, and were if anything too sharply pointed. To overcome these disadvantages Hegar's dilators (Fig. 76) are now made longer, and the metallic bougies now used are about the same length as a male catheter, with a sharper curve than Hegar's, and are constructed of hollow metal tubes, with ends somewhat less pointed.



FIG. 76. — Uterine dilator (Hegar's improved).

There are numerous varieties of metallic bougies, with varied details in the length, the shape of the point, the curve, the weight, and the handle. Among these may be mentioned those of Matthews Duncan, Galabin, Macnaughton Jones, Heywood Smith, Peaslee, Godson, John Phillips, and Hayes. Those of the last type (Fig. 77) and Matthews Duncan's (Fig. 78) are probably the best.

The best size to begin with is one with a diameter of four milli-



FIG. 77. — Uterine dilators (Hayes').

metres, and each succeeding size should vary in diameter not more than one millimetre. These bougies should be numbered according to their diameters. A case is occasionally met with where one millimetre seems too large a difference; and it is therefore advisable for hospital use to have some made with half a millimetre difference. In private, the difficulty is overcome by giving more time, or by having always in the bag

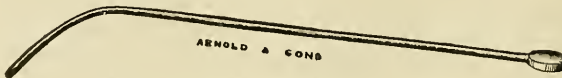

FIG. 78. — Uterine dilator (Matthews Duncan's).

a Goodell's two-bladed parallel dilator (Fig. 83), which will speedily overcome the resistance, so that the next sized bougie may be used. Such metal bougies as these involve very little friction, follow the pelvic and uterine curve easier, and, owing to their greater length, allow greater facility of manipulation. Their points being less tapering they also dilate the uterus right up to the fundus.

With these bougies, and with accelerants to dilatation as suggested, the usual time taken to dilate the uterus so as to admit the finger is about fifteen or twenty minutes. Thus I myself dilated and digitally

explored the uterus in two patients for hæmorrhage; curetted both for fungous endometritis; dilated another uterus for dysmenorrhœa, all under ether; and performed another small operation under gas, in exactly sixty minutes, without unusual haste.

The Operation. — The patient having been duly prepared by previous purgation, the vagina having been douched, and all antiseptic precautions having been taken as already described, the patient is anæsthetised, with ether for choice, and is placed either in the lithotomy position — Clover's crutch (Fig. 79) being employed to keep the legs up — or else, as some prefer, in the Sims' position.

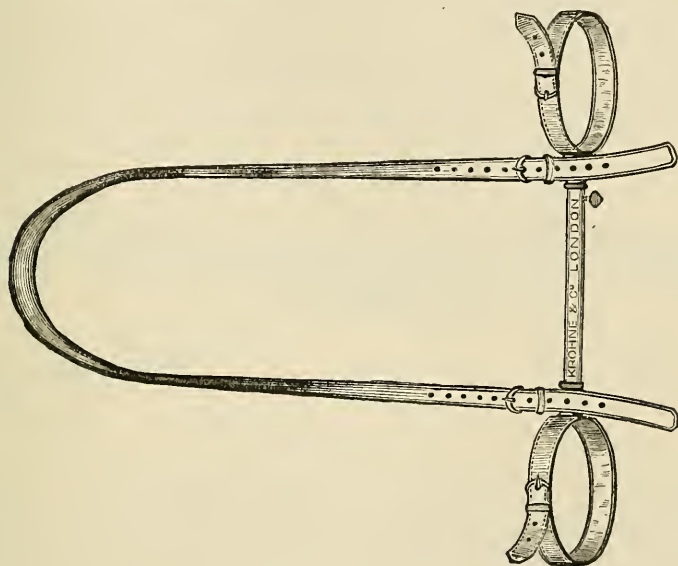

FIG. 79. — Clover's crutch.

The vagina is then again cleansed with a 1 in 2000 sublimate solution, and the operator's hands and the instruments being prepared as stated, the anterior lip (the uterus being assumed to be anteverted) is seized with a volsella forceps, drawn downwards, and held steady. This straightens the uterine curve, and prevents the strain on the ligaments which must occur if the bougies are passed without the uterus being thus fixed. A uterine sound is next introduced to ascertain the exact curve of the uterine cavity when thus drawn down; and then the smallest sized bougie is steadily passed, so that it may not be jerked through the internal os uteri as its spasm passes off, and perhaps made to impinge roughly against the fundus.

Some recommend that the operator should hold the volsella forceps whilst passing in the bougie so as to estimate the amount of force being used, but this is not advisable. An assistant should hold the cervix

immovably, and the operator should then pass up two fingers (a speculum should not as a rule be used) to the cervix, and introduce the bougie along them; with some experience, the operator can estimate very accurately how much force he is employing. It is important to use a volsella forceps which will not readily tear or cut its way out, and for this reason Teale's forceps (Fig. 80), which has several blunt teeth on each face, is the best, as it seizes the anterior lip bodily, and if the ratchet on its handle is efficient it practically never slips off.

The time which should elapse between the passage of succeeding bougies varies greatly. If a bougie has been introduced with difficulty, time should be allowed for it to get loose by relaxation of the cervical fibres; this can be tested by partially withdrawing it and feeling whether it has become looser in the grip of the os internum. Perhaps one to three minutes may be needed for this relaxation to occur, but as a rule a few seconds suffice. An assistant should remove the

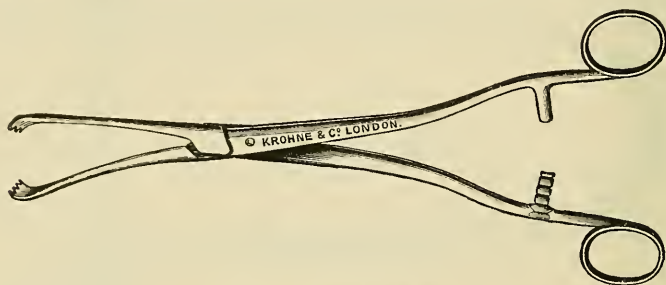

FIG. 80. — Teale's forceps.

bougies, when the operator has ascertained that they are ready for removal, and should dip them in warm carbolic solution in case the operator should find that the next size will not enter, and the previous size be again required. By allowing an assistant to remove each bougie, the operator is enabled to have in his hand the next sized bougie, ready, warmed and oiled, for immediate insertion. This is an important detail, as the spasmodic contraction of the cervix, even under deep anaesthesia, is remarkably persistent, the pelvic reflexes not being annulled till after the conjunctival reflexes are quite absent.

The extent of the dilatation required will vary according to the nature of the case. If a digital exploration be required, it is usually sufficient to dilate so as to admit the little finger, especially if the cervix can be drawn well down. This will enable the operator to diagnose a polypus, malignant disease, or fungous endometritis; but he must not be satisfied till he has succeeded in feeling, if possible, the whole of the endometrium, including the two cornua, which are favourite spots for placental polypi and hypertrophic endometritis. The finger can explore uteri which are considerably longer than the examining finger if the other hand be used to press down the fundus from over the pubes; care being taken that the



bladder is empty. If malignant disease be diagnosed, no further dilatation is required, hysterectomy being needed if otherwise indicated; or if the diagnosis be uncertain, the curette or scissors will be wanted to remove a piece for microscopical examination. If a fibroid polypus be found, further dilatation may be needed to admit the scissors, forceps, or wire écraseur along the finger. If fungous endometritis be detected a curette can be at once used. If a bit of placenta be found, it may usually be detached by the finger tip.

Sometimes the diagnosis of fungous endometritis is made after the passage of a few bougies, by pieces of characteristic material coming away; but it is only safe to accept this as the sole condition in small uteri, as it is not unusual to find this state of the endometrium complicating both submucous fibroid and polypus.

It is evident that the amount of dilatation for exploratory purposes really depends upon the size of the operator's little finger, or rather upon the size of the second joint of that digit; and this is a matter of considerable moment, as fingers vary several millimetres in diameter,

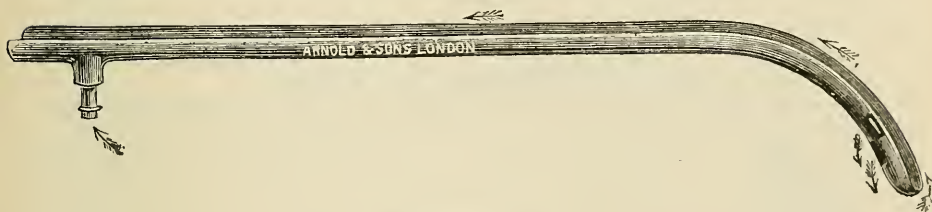

FIG. 81. — Budin's tube.

and any risk to the patient is necessarily proportional to the amount of dilatation required. It is for this reason that diagnosis should be made by the little finger, and not, in cases of rigid cervix at all events, by the index finger. Usually the fingers of the left hand are smaller than those of the right.

Whatever be the object of the dilatation, and whatever be the subsequent procedure (curetting, removal of polypus, etc.), it is advisable to apply to the endometrium some strong antiseptic counter-irritant, such as iodine liniment or iodised phenol, on a Playfair's probe, which should be covered with as much wool as will easily enter the dilated cervix.

To permit free drainage, and to prevent uterine colic following the application of the iodine, a piece of iodoform gauze should be passed up to the fundus in the manner previously described, and should not be removed till next morning when the vagina will also be douché.

Some operators prefer not to apply any antiseptic after dilatation, unless purulent endometritis is present, or the discharge indicates the existence of a septic intra-uterine condition. It is advisable, however, if this be not done, and if a flushing curette be not subsequently used, to wash out the uterus thoroughly with iodised or carbolised water at a temperature of about 118° F., by means of a double-channelled tube of

glass or celluloid, such as Budin's (Fig. 81), or Graily Hewitt's glass tube (Fig. 82), or a metallic one, such as Bozeman-Fritsch's.

The Dangers of Rapid Dilatation. — The risk of rapid dilatation is very small if carried out thus. There is hardly ever any subsequent pyrexia; if there be, it is almost always in cases where malignant disease has

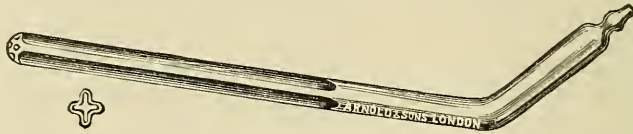

FIG. 82. — Graily Hewitt's uterine tube.

been diagnosed, and then probably arises from septic absorption. In cases of tubal disease there is sometimes a little inflammatory reaction; but if free drainage be provided this soon passes off, and any chronic salpingitis, which existed as a sequence to the concurrent endometritis, often disappears within a few weeks (C. H. F. Routh, Doleris, Trelat). "Lumps in the pelvis," such as are due to ovarian congestion or swollen tubes, are not necessarily contra-indications to rapid dilatation, for slow dilatation by tents would be more risky (see curetting).

If by some accident — such as roughness on the part of the operator or, as more often happens, in extreme softness of the uterine tissues, as in some cases of subinvolution, or where the tissues are friable as in carcinoma — perforation of the uterus has occurred, serious results may not follow, provided that antiseptics has been thorough, and recognition of the accident immediate. The proper treatment in such cases is to cease further dilatation, and after cleansing the vagina and endocervix, lightly to pack the uterine cavity with gauze. In a few hours lymph will have covered over the perforation, and probably no symptoms beyond some sickness will ensue. All cases of perforation do not terminate thus satisfactorily, but these are either in themselves septic, or antiseptics have been neglected; or the accident has not been recognised, and more bougies have been passed, possibly even a curette used, and the bowel injured. Fortunately such accidents are very rare, but the possibility of the uterine tissue being extremely soft must be kept in mind. If it be realised that the perforation through the uterus is extensive, or the uterine contents septic, or that the bowel have come down into the uterine cavity, the abdomen may be opened; and if the rent cannot be sutured hysterectomy should be performed: some operators would at once proceed to perform vaginal hysterectomy, being particularly careful to ensure subsequent good drainage by gauze.

If the cervix be rigid, slight lacerations of the mucous membrane usually occur, and occasionally when the exploring finger is introduced rather deep splits are found, usually on the left side; but in a series of several hundred cases I have never seen permanent mischief result, or even inflammatory troubles follow. Such tears seem to commence at the

level of the os internum, and may be suspected if a bougie pass easily after the preceding smaller size entered with difficulty.

Occasionally hæmorrhage suddenly arises during a dilatation, as for instance when a piece of placental polypus becomes detached, appearing, it may be, at the os externum when the bougie is withdrawn. In such a case the hæmorrhage is sometimes alarming, and time cannot be wasted by attempting further dilatation with a view to explore with the finger — though it may be worth while to pass in the curette and rapidly scrape the endometrium to remove any more placental tissue, and thus encourage retraction: but if the hæmorrhage persist, as it probably will, the uterus should be plugged at once with antiseptic gauze, and the plugs retained in utero for twenty-four hours, by which time the uterus will be sufficiently dilated to admit the finger if necessary. The hæmorrhage appears to be

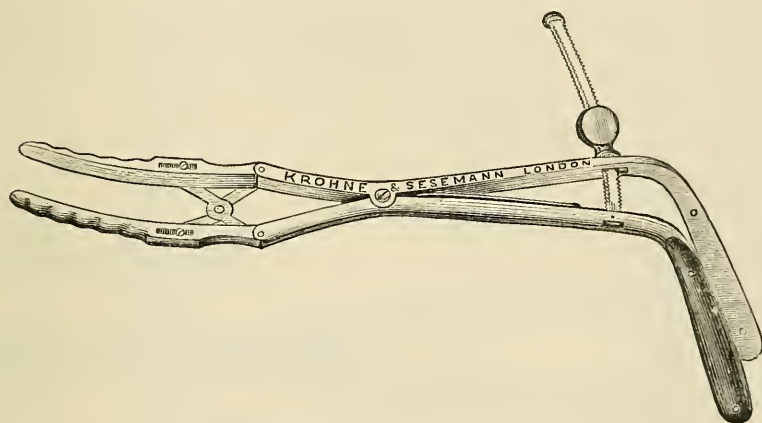

FIG. 83. — Goodell's two parallel-bladed dilator.

arrested by pressure and by the blood coagulating readily upon the gauze fibres, and not, at all events, solely by the uterus being excited to contract by the presence of a foreign body: for it is evident that even if contraction and retraction of the muscles at the site of the hæmorrhage be the immediate effect of the gauze-packing, a secondary effect is a further passive dilatation and relaxation, and yet hæmorrhage does not then recur.

β. Rapid Dilatation by Two and Three Bladed Dilators. — There are some who prefer this type of dilator, but none of these instruments has met with universal approval, owing to the irregular way in which they dilate, the time occupied by the process, the more frequent failure, and the greater tendency to tearing of the cervix. There is, however, a great advantage in having one of these instruments at hand when dilating with bougies, as it occasionally happens that the operator finds it difficult to pass the next sized bougie, or possibly a particular bougie may have been forgotten. The possession of a dilator of this type, like Goodell's, is then

most opportune, and its employment will enable the further dilatation to be made with the other bougies.

The preliminary steps are identical with those required for dilatation by bougies, both as regards antisepsis, anæsthesia, and the position of

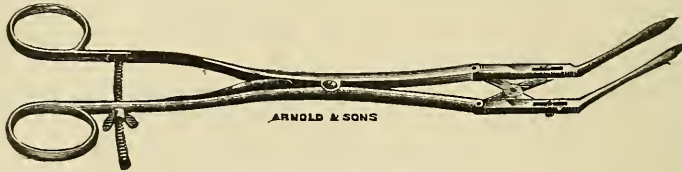

FIG. 84. — Uterine dilator (Ellinger's).

the patient. The cervix must also be seized and steadied, and the uterus drawn down; it is advisable to use a duckbill speculum, so as to introduce and screw up the dilator by the aid of inspection. The best instruments are Goodell's (Fig. 83) or Ellinger's two-bladed dilators (Fig. 84), or Sims' three-bladed dilator (Fig. 85). The two former are the best, as they dilate by parallel blades.

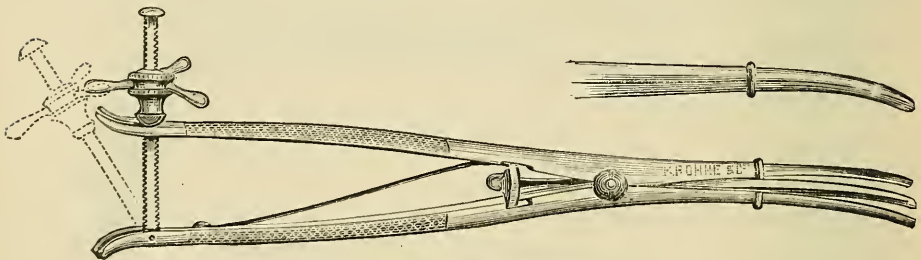

FIG. 85. — Sims' three-bladed dilator.

For the employment of all these instruments the cervix should be somewhat patent; and if it be found that they cannot enter the cervix above the os internum, a smaller sized dilator, such as Palmer's two-bladed dilator (Fig. 86), should be first used, or a few bougies passed. The most important precaution in dilating by these instruments is to avoid screwing up the blades in one diameter of the cervix only. They should be opened very gradually in the transverse diameter first, then unscrewed and rotated, and again opened in another diameter, and so on till distension of the muscle fibres has been uniformly effected all round. In a soft, relaxed cervix dilatation can be easily effected by this means; but in the nulliparous rigid cervix complete dilatation is often impossible, or if possible, open to serious risk.

In cases of dysmenorrhœa, where moderate stretching is to be effected as a method of treatment, dilatation by these instruments is fairly satisfactory; and if it be desired to attempt a partial dilatation without anæsthesia, a small-bladed instrument like Palmer's, Priestley's (Fig. 87),



or Collins' may be passed in, and a few turns given to the screw. Sometimes great improvement follows as regards the pain and sickness usually accompanying the period, which should not be more than two or three

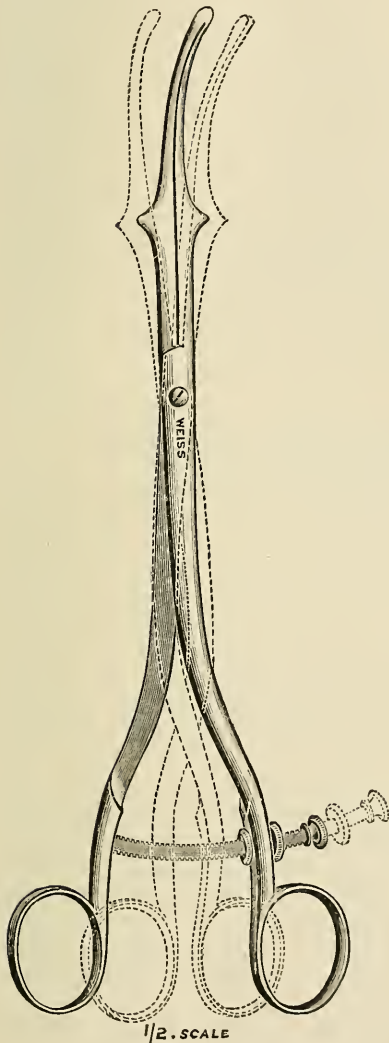

FIG. 86. — Palmer's two-bladed dilator.



FIG. 87. — Dilator (Priestley's).

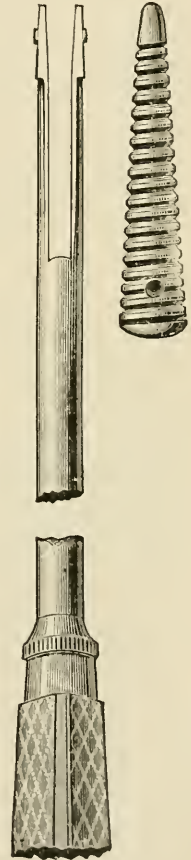

FIG. 88. — Uterine dilators (Reid's).

days distant. The danger of such a partial proceeding is that there is a risk of neglecting complete antisepsis, and serious inflammation might then follow. There are many instruments on the same principle, such as

Gardner's, Wathen's, Buck's, Simpson's, Pearson's. Some of these are worked by hand-pressure, some by screws.

γ. Rapid Dilatation by Miscellaneous Instruments.—Such instruments are numerous. A few will suffice as types. Dr. Reid of Glasgow has invented a conical screw dilator, with different-sized screws. They answer well in the inventor's hands, or when his instructions are followed; but his method is not satisfactory in cases of rigid or indurated cervix, as unless the tissues yield readily the biting of the conical screws causes abrasion of the lining membrane. Mr. Lawson Tait, again, has some conical dilators, which are, however, only "rapid" when compared with tents, for two or three hours at least are required for each sized conical wedge to do its work. They are cones fixed to a vaginal stem or holder attached to elastic bands, which pass up, two in front and two behind, to be fastened to a belt or waistband. By regulating the tension of these bands the direction and amount of pressure can be arranged; but inasmuch as these details require careful watching and readjustment, the method is only suitable for hospital work, and it is clearly capable of causing dangerous upward pressure if by any accident the bands are not loosened when the dilatation of the cervix is completed. Fritsch has also invented some conical dilators, to be used manually just as the graduated bougies are used.

More Madden's dilator is two-bladed, but instead of dilating equally along the cervix, it dilates from its upper end, where the ends most diverge; so that the uterus is dilated first, then the os internum, and gradually, as the instrument is drawn out, the endocervical canal becomes stretched. It is no improvement upon such instruments as Goodell's two-bladed dilator.

Duke's two-bladed dilator has a more decided curve, and its blades, which open by a powerful screw, are conical in shape.

Reverdin uses a two-bladed dilator with one blade hollowed out for flushing, and he states that dilatation is accelerated by the continuous flow of a warm antiseptic solution.

C. Combined Gradual and Rapid Dilatation. — After failing to dilate the cervix to the "exploratory" size by rapid dilatation, it is not safe to continue the dilatation with tents until the abrasions have healed. The mucous membrane is necessarily torn here and there after such a trial, and septic absorption is very prone to occur. In such a case the best plan is to antisepticise the endometrium thoroughly, and then to pack the cavity gently but firmly with 10 per cent iodoform gauze, as before described. This will efficiently dilate the uterus in twenty-four hours without any appreciable risk.

Previous to rapid dilatation in nulliparous women, it is the routine custom of some operators to dilate the cervix partially overnight by means of tents, preferably laminaria. This undoubtedly softens, and begins to dilate the cervix, but is rarely necessary, as it usually gives the patient a very uncomfortable night; and if the aids to rapid dilatation described on page 280 be made use of, this preliminary dilatation can be dispensed

with, or accomplished much more safely, with far less discomfort and quite as effectually, by stuffing the endocervix with gauze, as described on page 274.

D. Dilatation with Incision. — Occasionally the os uteri externum remains rigid, while the rest of the cervix has become relaxed and dilatable; it may then become necessary to divide the rigid rim bilaterally. A common instance of this is where an intra-uterine polypus has been partly extruded, and has fully dilated the whole cervix, except a rim of rigid tissue at the os externum. Here a slight notch on each side, the loss of a little blood, and the yielding of the rigidity, will afford sufficient space, and dilatation can then be proceeded with.

Incisions for this purpose, and for the division of the os externum in cases of pinhole os and conical cervix, may need to be somewhat more than mere notches. Then Küchenmeister's scissors (Fig. 89) should be

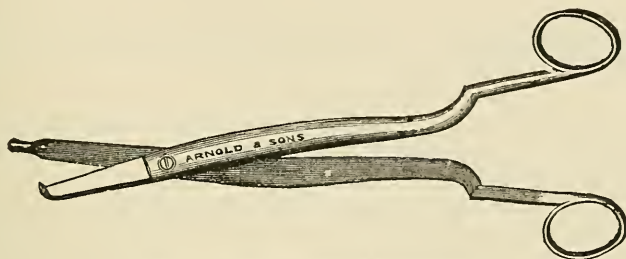

FIG. 89. — Scissors, uterine (Küchenmeister's).

used instead of ordinary scissors or bistouries. Küchenmeister's scissors have a probe-pointed blade which is passed into the cervical canal, and a hooked blade which grips the cervix on its vaginal aspect and prevents its slipping, and so dispenses with the use of sharp hook or volsella forceps. The extent of the desired incision is regulated by the distance of the hooked blade from the external os uteri, as this blade is the cutting one.

In all cases where a mere temporary dilatation is needed, the incision should be sewn up at once with wire or silk-worm gut, lest ectropion and chronic endocervicitis may ensue.

Incision by means of a Paquelin's cautery, or the galvanic cautery with the platinum terminals brought to a dull red heat, is very efficacious in preventing hæmorrhage; and it may advantageously be used when it is desired to prevent rapid reunion of the incised cervix, as, for instance, when the os uteri externum has been divided for "pinhole os." The cautery, however, should never be used to incise the internal os uteri or the cervix high up, where the branches of the uterine artery may be found, as, even if it prevent hæmorrhage at the time, secondary hæmorrhage is very likely to occur; and owing to the necessary sloughing, perfect asepsis at that level is very difficult to maintain. If it is desired to prevent closure of the incision, and the cautery has not been employed,

the raw surfaces should be touched with iodine liniment; and a piece of gauze, soaked in iodised glycerine, should be kept in the cervix for some days, beyond the upper limit of the cut, being changed of course daily, and a vaginal douche given at the intervals.

If hæmorrhage be severe, it may usually be arrested by plugging the cervical cavity with gauze; or the bleeding point may be touched with the actual cautery, though, as has just been stated, this has its disadvantages. If this do not arrest the bleeding, the uterine artery, or the branch going to the cervix, must be tied.

In those very rare cases where, owing to the failure of a rapid dilatation, hysterotomy to the level of the os internum has been decided upon, it has been very strongly recommended by such authorities as Schroeder, Martin, and Pozzi that the uterine artery, or rather the large branch which enters the cervix at the base of the broad ligament, should be tied. This can be done by a curved needle, which should be entered precisely as when the artery is tied for vaginal hysterectomy, except that there is no need to divide any mucous membrane before passing the needle. After reuniting the incisions in the cervix, or at all events after the lapse of twelve hours, the ligatures should be removed to prevent ulceration of the mucous membrane where it was included in the knot. If this preliminary ligation of the arteries were efficiently performed, the greatest danger of the operation, that of death from primary hæmorrhage, would be entirely obviated. The danger from sepsis has, of course, to be otherwise combated.

After such an "high" operation it may be advisable to introduce a stem pessary, such as Meadows' glass stem, till healing is completed. With rest in bed and perfect antisepsis this ensures free drainage. For this "high" operation Küchenmeister's scissors, which can only cut to the level of the vaginal vault, are not suitable; for the cervix need not be cut through from its cavity into the vagina except at the os externum. Practically the simplest plan is to dilate the cervix partially, and then to incise the neck of the uterus at the desired level, and to the desired extent, by means of a Sims' knife (Fig. 90) set at a suitable angle, or by



FIG. 90. — Sims' metrotome.

a straight probe-pointed bistoury, which can be easily introduced if the uterus be drawn down by a volsella.

Formerly single hysterotomes, such as Simpson's or Priestley's, were used, but they have no advantage over a probe-pointed bistoury, which is far safer than the double hysterotomes, such as Greenhalgh's and its modifications (Savage's or Peaslee's), all of which are apt to cut more deeply on the side where there is less resistance, and have been the cause of most of the disasters to which the operation has led.

ii. *Curetting the Uterus.* — Curetting was introduced by Récamier in 1843, and was so vehemently opposed that it fell immediately into dis-



repute, though in 1850 Récamier was still advocating his curette for the "removal of intra-uterine fungosities," which he had discovered to be often the cause of obstinate metrorrhagia. In 1846 Sir Charles Locock described his scoop for the removal of malignant nodules, and soon afterwards Simon's scoop was also recommended. In 1861 C. H. F. Routh



FIG. 91. — Simon's uterine scoop.

somewhat modified Récamier's curette, and read a paper at the Obstetrical Society of London, giving three cases of metrorrhagia cured by its use after a diagnosis had been made by slow dilatation and digital exploration. In 1866 Sims introduced his sharp curette with a malleable handle. This



FIG. 92. — Sims' pliable curette.

continued to be the favourite curette till about 1874, when Thomas introduced, and Mundé strongly advocated, a "dull curette of flexible copper wire," and this was used almost universally in America for some years. In the same year Hegar, Kaltenbach, and Olshausen brought its use prominently into notice in Germany; and in France, Trouseau, Nélaton (1861), Maisonneuve, and Nonat (1869) had occasionally made use of it. In England it was long in coming into favour, for in spite of its occasional use, as stated above, it was opposed at first by such men as Barnes and Atthill, though in 1873 the former, and somewhat later the latter, advised its use in serious cases.

With such well-known gynæcologists as Courty (1866), Scanzoni (1861 to 1865), Thomas (up to 1871), Schroeder, and Colucci (1877) writing against the use of the curette, it is not surprising that very little progress was made; and in spite of the recommendation of many strong advocates, it is probable that it would never have become so universally employed as it is now if the era of antiseptics and of anæsthetics had not made it both safe and easy of execution.

*Indications for Curetting.* — This operation may be used merely to make a diagnosis of the state of the endometrium, by scraping off a small piece of the mucosa for microscopic examination. For such a purpose a small exploratory curette can be used without previous dilatation. Curetting is done both for hypertrophic and atrophic endometritis. It is done also for cases of septic or infective endometritis, with their resulting purulent discharges, in order to prevent sequential tubal and periuterine complications from extension of the inflammation. Whether the process advance through the tubes, or through the lymphatics of the uterine tissues, the result is very serious, and a timely curetting may prevent such disaster.

Even if the periuterine tissues be already involved, it is good practice to remove the infective focus in utero by an efficient curetting; and if it be considered necessary to open the abdomen and deal with some serious condition there which has followed the endometritis, it is right to curette the uterus beforehand or simultaneously. In many cases the periuterine exudation, whether in tubes or peritoneum or as phlegmon in the cellular tissue, will disappear after a careful curetting and packing of the uterus with gauze to ensure free drainage; and unless an abdominal section be clearly necessary, this minor operation should be first tried. The time will almost surely come when the practice will be to curette the uterus, or otherwise cure the endometritis, in all cases of tubal or peritoneal inflammation of uterine origin, in which there is no abscess.

Sometimes an endometritis exists with hæmorrhage as its chief symptom. This is usually hypertrophic and adenomatous in nature. For this state also curetting is indicated.

Curetting is also needed for the removal of placental or membranous débris retained after labour or abortion. Such a condition is almost the only indication for a blunt curette, for the uterus may be very soft; but in such cases the cervix is generally so patent, or so easily dilated, that the insertion of the finger involves no difficulty, and the piece of retained placenta or other matter can almost certainly be removed by the fingertip alone. If, however, the discharge be septic, and especially if general septicæmia be setting in, a deep and thorough curetting of the whole endometrium is imperatively necessary if the patient's life is to be saved.

*Varieties of Curettes.* — Curettes should be provided with some arrangement of the handle or shaft to prevent rotation, and to enable the operator to know which is the sharp and which the blunt edge of the end. Some curettes have a sharp loop at one end, and a blunt at the other; and as these loops are on opposite faces of the shaft, the outside end gives sufficient indication of the direction of the intra-uterine end. Some curettes have loops of different sizes or curves at the two ends. Amongst such are Gervis' (Fig. 93), Récamier's (Fig. 94), and



FIG. 93. — Double uterine curette (Gervis').

that used at St. Bartholomew's Hospital. The first is sharp-edged, the second is blunted: all are excellent instruments, but it is desirable

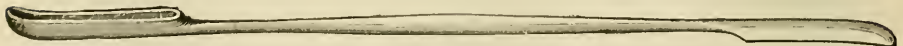

FIG. 94. — Récamier's curette.

to have at least one end of the Récamier's curette sharpened for deep curetting. For scraping away the friable tissues of a malignant growth — as a palliative measure, or preparatory to a radical operation — Volkmann's

or 'Thomas' uterine scoops (Fig. 95) are better than ordinary curettes. Bell's dredging curette (Fig. 96) is also very useful in malignant cases,

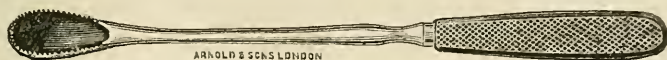

FIG. 95. — Uterine scoop, or spoon saw (Thomas').

especially where the cervix is too friable to be grasped with the volsella forceps, and an intra-uterine diverging tenaculum has to be used. In such a case Bell's curette will clear a way along the uterine cavity, so as to admit the tenaculum, better than any other instrument. It is not so suitable for ordinary curetting unless the uterine cavity be normally regular in outline; though much may be done, by outside supra-

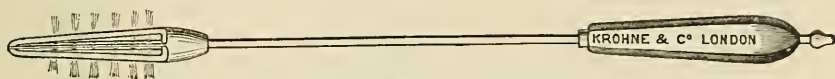

FIG. 96. — Dredging curette (Bell's).

pubic pressure, to bring the different parts of the endometrium in contact with the instrument, which has other advantages, and can be constructed with a hollow shaft for flushing purposes. Jessett's watch-spring dredging curette is more dangerous, but is otherwise on the same lines. Both these instruments leave too much to chance, and most operators would therefore prefer an ordinary looped curette, which is more generally useful.

Flushing curettes — that is, curettes with the shaft hollowed out from the end of the handle to the space within the loop of the scraping end — are very useful, and may be made like Duke's, with the shaft only partly



FIG. 97. — Uterine flushing curette (Auvard's).

hollowed; or like Auvard's (Fig. 97), with a place on the shaft in which to dip the pulp of the index finger to secure steadiness; or like Routh's

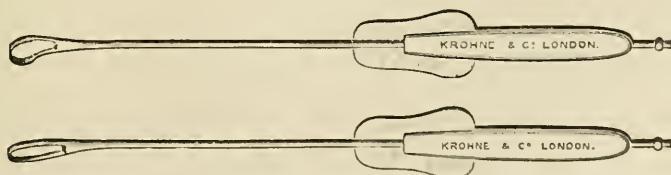

FIG. 98. — Routh's flushing curette.

(Fig. 98), which is longer in the shaft, has the tubing attached to the extreme end of the handle, and, half-way along the shaft, has a flat plate

to lie in the palm of the hand to steady the instrument and prevent rotation.

*The Operation of Curetting.*—It may be assumed that dilatation has been performed, that sufficient exploration of the uterus, by sound, exploratory scraping, or insertion of the finger, has been made, and that curetting is indicated.

The patient should be in the lithotomy position, both to facilitate the operation and to permit a perfect irrigation. The cervix is steadied and lowered as in rapid dilatation, and the largest-sized curette which will readily enter is passed up to the fundus, and then withdrawn with the sharp edge against the mucosa. This is repeated all over the intra-uterine surface. Special care is taken at the two cornua, as clumps of hypertrophic tissue are apt to collect there; to get at them it may be necessary to use a smaller curette, or one with the end set at a different angle. The cervix also should be subsequently curetted. In curetting, pressure with the sharp end should be firm and equal; and in going over the surface again to make sure (if possible) that all of the mucosa has been removed, it will be noted that if the curette cause a grating feeling or sound, it indicates that the mucosa has already been removed; but if no such sensation is produced, the lining membrane is still intact at that spot, and needs further attention.

*After Treatment.*—The uterus should be washed out with an antiseptic douche at about 118° F., if no flushing curette has been used; and then its raw surface should be painted freely with iodine liniment, carried up through a speculum on a probe armed with plenty of wool. In any case where septic or infective endometritis exists, the uterus should then be packed with iodoform gauze to encourage free drainage; if further intra-uterine treatment be indicated, the gauze, which should be removed in twelve hours, should be replaced, and the uterus kept patent. If there should be severe hæmorrhage this packing should also be resorted to, done however more tightly, with a firm vaginal tampon below. In this latter case the uterine tampon may be left in for twenty-four hours. In most cases antiseptic douches are advisable for the first week, after which time the patient may get up and may resume her ordinary duties in a fortnight.

iii. *Alternatives to Curetting.*—Excluding serious operation like hysterectomy, always unjustifiable in cases where curetting is an alternative, these cases of endometritis must either be treated palliatively by curetting or by some escharotic.

Minor palliative methods have been described under the heads of intra-uterine medication, and dilatation by gauze-packing, and need not here be again referred to, except to say that, as stated on page 276, some of the mild and uncomplicated cases of endometritis will yield to them.

Treatment by escharotics, such as chloride of zinc, nitric acid, or electricity with strong currents, involves the formation of extensive sloughs, the depth of which cannot be regulated. Such a slough is itself a danger, and, as the surface of repair which is left has very little



protective epithelium to defend it against the passage of pathogenetic germs, the slough is thrown off by suppuration, and an atrophic endometritis results. Curetting, therefore, preceded by dilatation and followed by gauze-packing, is by far the safest method of treating these cases; and when repair begins, the uterus is relieved of the septic process. As Baldy says, "new leucocytes and plasma cells are not forced to exercise their phagocytic properties by battling with pathogenic germs, but the plasma cells have a healthy pabulum, and devote their entire energy to the work of regeneration, which is not merely non-suppurative repair, but is histological growth."

*Reproduction of the Endometrium.*—After a thoroughly antiseptic curetting the endometrium is reproduced in about two months, that is, between the second and third catamenial periods following the operation. After destruction of the endometrium by acids or other escharotics,

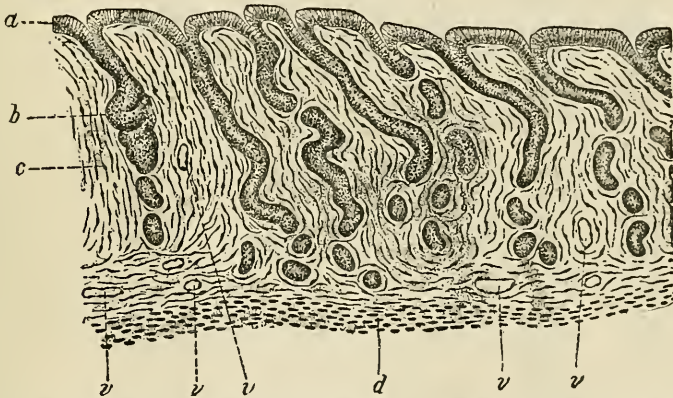

FIG. 99.—Vertical section three months after curetting. *a*, Epithelium; *b*, new-formed glands; *c*, connective tissue; *d*, muscular tissue of the uterine walls; *v v*, blood-vessels. (From Baldy's *Text-Book of Gynæcology* by kind permission of the editor of the *Nouv. Archiv. d'obstet. et de gynécolog.*)

suppuration ensues, with the formation and separation of a slough; and the endometrium is very imperfectly re-formed after the lapse of three or four months. In both cases the mucous membrane is re-formed mainly from the cells of the connective tissue which covers the muscle layers of the uterus; but there is an essential difference in the new membrane formed under these circumstances. After chloride of zinc paste has been used the connective tissue layer is much injured, and may be destroyed; for the action of this caustic is very uncertain, and may, as is desired by those who use this agent for cancer of the uterine body, lead to destruction of the muscle also.

After curetting, the connective tissue is rarely injured; and in addition to this, it is more than probable that the most skilful operator would almost invariably leave islets of mucosa from the edges of which new epithelium would spring. The bases of many of the uterine glands also dip down so far, some even into the muscular layer, that they certainly

would not be reached even with a sharp curette, and they may therefore be additional sources of epithelial regeneration.

Sections of a uterus taken three months after curetting show (Fig. 99) under the microscope healthy ciliated epithelium, with newly formed glands dipping down into the connective tissue, which is richly

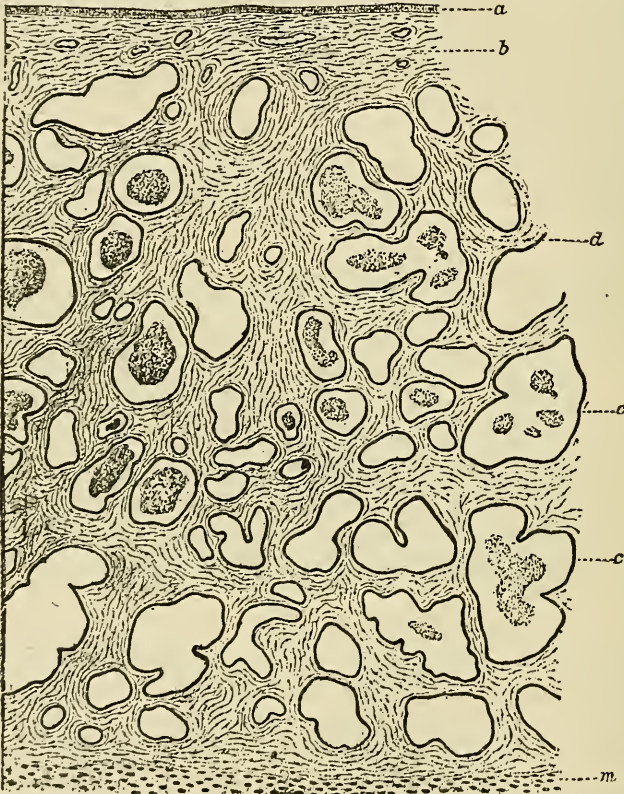

FIG. 100. — Vertical section of the uterine mucous membrane fifty-five days after the application of a caustic. *a*, Epithelium; *b*, connective tissue; *c c*, section of the glands which have undergone cystic degeneration; *d*, tubular glands enormously dilated; *m*, muscular tissue of the uterine wall. (From Bably's *Text-Book of Gynaecology* by kind permission of the editor of the *Nouv. Archiv. d'obstet. et de gynécolog.*)

supplied with blood-vessels. In other words, the endometrium is absolutely normal. This happy result can only be expected when no fresh infection of the parts has meanwhile occurred, and when suppuration has been absent. On the other hand, microscopical sections of the uterus following the use of chloride of zinc (Fig. 100) show an imperfect non-ciliated epithelium, greatly exaggerated connective tissue, and a few partially formed glands, which do not open on to the surface of the endometrium, but are mostly distended into small cysts from blocking

of their surface orifices. The condition is, in fact, one of chronic interstitial endometritis, with its accompanying atrophy of the epithelial elements.

Pregnancy after the use of an escharotic, used as assumed above, is very rare. After curetting it is, however, very common, and indeed, in suitable cases, this operation has cured many women of an obstinate sterility. Heinricius collected statistics of this, and showed that out of 52 patients, whose history after curetting he was able to learn, 16, or 30 per cent, conceived; he states that pregnancy commenced in two cases five weeks, and in one case eight weeks after the operation.

AMAND ROUTH.

#### REFERENCES

1. ALBUTT, T. CLIFFORD. *Goulstonian Lectures*, 1884.—2. AUVARD, A. *Traité Pratique de Gynæc.* 1894.—3. BALLANCE and EDMUNDS. *Treat. on the Ligation of Arteries*, 1891, pp. 259 and 271.—4. BALDY, J. M. *Text-Book of Gynæc.* 1894, p. 227.—5. BARNES, ROBERT. *Diseases of Women, etc.*—6. BRAITHWAITE, JAMES. *Brit. Med. Jour.* June 29, 1895, p. 1438.—7. CHAMPNEYS, F. H. *Med. Soc. Trans.* vol. xv. 1892, p. 374.—8. DICKENSON, DR. R. L. *Amer. Jour. of Obstet.* Jan. 1895.—9. DOLERIS. *Nouv. Archiv. d'obstet. et de gyn.* vol. vi. p. 401.—10. FERRIA. *Gazetta Medica di Torino*, Dec. 13, 1894.—11. GOODELL, WILLIAM. *Lessons in Gynæc.* p. 98; *Med. Gynæc.* 1895.—12. HEAD, HENRY. *Brain*, vol. xvi. 1893, pp. 1 to 134.—13. HEINRICIUS. *Gynæc. og Obstet. Med.* vol. vi. No. iii. p. 134.—14. HERMAN, G. E. *Obstet. Soc. Trans.* vol. xxxvi. 1894, p. 250.—15. LEWERS, A. H. N. *Lancet*, 1891, p. 1119.—16. MALCOLM, J. D. *Med. Chir. Trans.* vol. lxxi. 1888, p. 43.—17. MARTIN, A. *Path. und Ther. der Frauenkr.* 1887, p. 26.—18. MORE, MADDEN. *Brit. Med. Jour.* 1884, vol. ii. p. 1068.—19. OLSHAUSEN. *Cent. für Gynæc.* July 1888.—20. PESSER, DE. *Annal. de Maladies des Org. Gen.-urin.* Jan. 1894.—21. PHILLIPS, JOHN. *Lanc.* 1887, vol. ii. p. 507.—22. Pozzi, S. (Syd. Soc.) *Treat. on Gynæc.* 1888, pp. 31 and 141.—23. ROUSING, THEODORE. *Hosp. Tidende*, Feb. 7, 1894.—24. ROUTH, AMAND. "Rapid Dilat. of Uterus," *Med. Soc. Trans.* 1892, p. 347.—25. ROUTH, C. H. F. "Conserv. Surg. in Pelv. Dis.," *Med. Press and Circ.* May 1894.—26. *Ibid.* "Cases of Menorrhag. treated by the Gouge," *Obstet. Soc. Trans.* vol. ii. 1860, p. 117.—27. SCHROEDER. *Zeitsch. f. Geb. und Gynak.* 1881, vol. vi. p. 29.—28. SCHULTZE, B. S. *Displacements of Uterus* (trans. by Dr. Macan), p. 222.—29. SLOAN, C. F., of Ayr. *Glusg. Med. Jour.* vol. x. 1862, p. 281.—30. TAIT, LAWSON. *Dis. of Ovaries*, 4th ed. p. 309; *Brit. Med. Jour.* May 15, 1886, p. 921.—31. THOMSON, H. F., of Dorpat. *Cent. f. Gynæc.* vol. xiii. 1889, p. 409.—32. TRELAT. *Annal. de gyn. et d'obstet.* Paris, May 1891.—33. TREVES, F. *Lettsom: Lect. Med. Soc. Trans.* vol. xvii. 1891.—34. VULLIET. *Nouv. Archiv. d'obstet. et de gyn.* 1886, p. 693.—35. *Ibid.* *Leçons de gyn. opératoire*, 1890, p. 78.—36. WRIGHT, A. E. "Methods of Increasing the Coagulability of the Blood," *Brit. Med. Jour.* July 14, 1894.

A. R.



## THE ELECTRICAL TREATMENT OF DISEASES OF WOMEN

THE successful employment of electricity in the treatment of the diseases of women is of very recent date. General attention was drawn to it in 1886, when Dr. Georges Apostoli of Paris published the results of five years' experience of its use in this class of cases, and at the same time gave a full account of the method by which he carried it out. That the method was new admits of no discussion. No doubt many attempts had been made in previous years to utilise electric energy in some form or other for this purpose; but the knowledge of these attempts was of value to Apostoli only in so far as it showed him what to avoid.

The limits of this article do not permit me to review the efforts of earlier workers in this field; and, indeed, but little purpose would be served by such a review. We may take it that the present position of electricity in gynæcology is simply this, that it consists of the application of Apostoli's methods with such slight modification of details as has been suggested by the experience of workers following on his lines.

I purpose in the following pages to consider this subject under these heads:—1. The armamentarium, or instrumental equipment, required in gynæcological electro-therapeutics. 2. The modes of making the applications. 3. The modes of action of the current. 4. The diseased conditions in women which can be treated by electricity, and an account of the modes of procedure in each.

**I. The Armamentarium.**—The suitable instrumental equipment of the gynæcologist for electrical treatment is a matter of the first importance, and deserves careful consideration. Much of the disappointment and failure which have ensued on attempts to carry out electrical treatment with currents of relatively considerable strength have resulted from the unsuitable nature or mismanagement of the battery and other instrumental means employed. It is essential, then, that the apparatus should be suitable and well cared for, otherwise vexation and disappointment are inevitable. It is sometimes forgotten that a battery is capable of giving out only an amount of energy corresponding to its size. When an ordinary portable "constant current" battery of thirty or forty small cells is found exhausted after a small number of sittings the practitioner is annoyed, and this method of treatment is called impracticable. But the failure is due to the employment of an unsuitable and inadequate source of energy.

We shall consider first, then, the most convenient and suitable form of *battery*. The current from the electric lighting mains of a continuous low pressure supply is the most convenient source of energy for the purpose in view; but this source is not as yet generally available. Con-



sequently the majority of practitioners must fall back upon some form of primary battery. The form of battery will depend on whether the treatment is to be carried out in the physician's rooms or at the patient's residence; in other words, whether the patient is to come to the battery, or the battery is to go to the patient. There can be no doubt that the former arrangement is much the more satisfactory; it permits the use of a large-celled stationary battery, and avoids the inevitable inconvenience associated with the carriage of a portable one. I shall consider first the most convenient kind of stationary battery.

Experience has shown that some form of Léclanche cell is the most suitable. The simplicity of its construction and the harmless fluid used are matters of great advantage. Any good form of cell, such as is used for electrical bells or telegraph work, will suffice. An excellent type of cell is sold by Mr. K. Schall (Fig. 101). The carbon element is a cylinder about 2 inches in diameter, pierced by a central channel  $1\frac{1}{4}$  inch in diameter. The mouth of the glass jar is surrounded by an india-rubber collar, which supports a lead flange attached to the carbon cylinder; the carbon thus hangs in the liquid, being half an inch clear of the bottom of the jar. This space prevents the formation of crystals on the lower end of the carbon. In the central channel hangs the zinc rod; this rod is attached to a china disc which rests on the top of the carbon cylinder in such a way as to prevent its shifting or coming in contact with the carbon. An india-rubber ring is slipped over the lower end of the zinc rod, which effectually prevents its touching the carbon cylinder at that point. The cell is thus of a simple and workmanlike construction, and has a very low internal resistance — a matter of some consequence. Whatever kind of cell is used it should be of at least a quart capacity. From thirty to forty of such cells will be required.

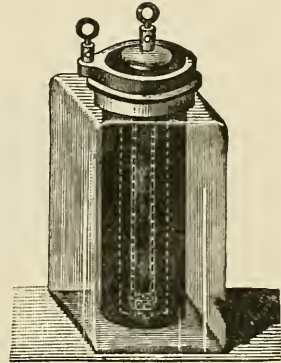

FIG. 101. — Léclanche cell.

The efficiency and length of life of such a battery will depend largely on the manner in which it is charged and set up; and the following instructions may be found of use: — The glass jars after being unpacked should be wiped inside and out with a dry cloth so as carefully to free them from straw and dust. Care should be taken not to damage in any way the coating of paraffin round the outer edge; the object of the paraffin is to prevent "creeping," and if it should be deficient or cracked it should be repaired by brushing a little melted paraffin over it. The jar should then be rather more than half filled with a saturated solution of sal ammoniac. The salt used should be nearly pure; the common or commercial form gives very unsatisfactory results. The rubber collars are then to be fitted, and the carbon cylinders put in. Great care should be taken that the outside of the jars be not wetted by

sparkling of the fluid. The introduction of the carbon will raise the fluid within 2 inches of the shoulder of the cell. The cell should be allowed to stand for twenty-four hours, at the end of which time the fluid will have sunk a little owing to the absorption of some of it by the porous carbon. The cells are now to be filled with plain water to a level of one inch below the shoulder; this will reduce the saturation somewhat, and avoid the risk of any part of the salt crystallising out. If the fluid used be fully saturated this change is apt to occur in cold weather, and crystals, forming in the space round the zinc rod, may ultimately make a bridge between the elements, an accident which will rapidly destroy the cell. The zinc rods may then be placed in position, and the cells arranged in their permanent places. The most convenient place is a dry roomy cupboard, the shelves of which should be varnished or covered with thick brown glazed paper. If a cupboard be not available, stout shelves must be provided. If forty cells are employed they should be arranged in two sets of twenty cells each on two shelves, each set consisting of two rows of ten cells. A clear inch should be allowed between each cell, and two or three between each row. In this way any cell can readily be removed for any purpose, and the cells periodically tested as to efficiency. Before being placed on the shelf each cell must be carefully dried from any stray drops of solution or moisture which may have been deposited on it. This precaution should not be omitted, as the efficiency and durability of the battery greatly depend on keeping the cells thoroughly dry on their external surface. The cells may now be connected up; the carbon of each should be joined to the zinc of the next by a piece of clean No. 18 copper wire, care being taken that the binding screws are well screwed up and the wires firmly held by them. This will leave a free carbon and a free zinc at the end of the battery; from these, pieces of insulated wire should run to a couple of stout binding screws fixed to one of the shelves. The binding screw connected with the last carbon will be the positive, and that connected with the last zinc will be the negative pole of the battery. A battery consisting, say, of forty cells, if tested by a volt meter, should give an electro-motive force of about 58 volts; and as the resistance of each cell, when in good condition, is about 0.5 ohm, the total resistance of the battery will be about 20 ohms. On short circuit, then, the battery will give, for a short time, nearly 2.5 ampères. With a good abdominal electrode properly applied, and a sound in the uterus, the resistance of the human body averages about 150 ohms; thus the battery will be capable of transmitting a current of about one-third of an ampère through the tissues of the patient. This is more than sufficient for all ordinary purposes; but as the electro-motive force tends to fall and the internal resistance to rise, it is well to be provided at the outset with a certain amount of surplus energy. If properly used and cared for, such a battery will prove efficient for a very long time. The following matters must be attended to if disappointment is to be avoided:—1st, The battery should not be allowed to remain idle for long intervals: if it happen not to be used for a few weeks at a time, crystals tend to form on

the zincs, and when next examined the internal resistance will be found greatly increased. If the battery is not to be used for a week or two, the terminals ought to be connected to a resistance, and a current of 50 or 60 milliamperes allowed to flow for five or six minutes at least once a fortnight. Attention to this will do much to prolong the life of a battery; nothing is worse for it than long periods of idleness. 2nd, From time to time the evaporation from the vessels should be made good by the addition of a little water. 3rd, Once a month each cell should be tested with a galvanometer to see that it is giving its proper quota of energy. This can be done without disconnecting the cells, by having two stiff copper wires attached to flexible leads connected with the galvanometer, with which the terminals of each cell may be touched. If any cell gives a smaller deflection than it should do, it should be removed and examined for the cause of the defect. This may be creeping of the fluid over the edge of the cell, or accidental contact of the plates in the fluid. The defect should be rectified, and the cell tested and returned to its place; but the battery may, of course, be used without the defective cell if those

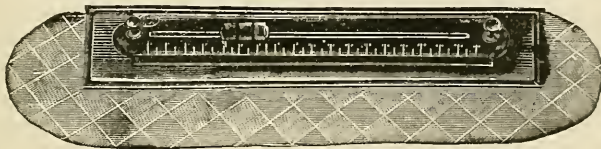

FIG. 102. — Carbon rheostat.

on each side of it be connected by a piece of stout copper wire. 4th, Any fluid accidentally spilt on or about the cells should be carefully dried up at once.

When such a battery has been in use for two or three years it will show signs of exhaustion; it should then be taken apart, the solution replaced by a fresh quantity, and the zincs reamalgamated. Any of the latter which are much worn should be replaced by new ones: this may be done at the cost of a few pence for each rod. With careful and regular use, and an overhaul now and then, a battery of this sort may remain in good working order for an indefinite time.

*The Current Regulator.* — For the control of this or any other battery some form of current regulator is necessary. For portable batteries the cell collector is probably the most convenient means; but for a fixed installation such an arrangement is impracticable. The regulation in this case is best effected by some form of rheostat or adjustable resistance. The most convenient form of rheostat at present available is one made of filaments or thin rods of carbon, which can be cut out or introduced into the circuit gradually by means of sliding metal pieces (Fig. 102). This arrangement permits of increase or diminution of the current to any extent without the least interruption or shock — a matter of essential consequence in the use of strong currents. Four of these rheostats,



mounted in series, will be found a convenient combination; and the following approximate values will be suitable: No. 1 of 200 ohms; No. 2 of 1000 ohms; No. 3 of 10,000 ohms; No. 4 of 100,000 ohms. With such a combination inserted into the circuit between the battery and the patient about 2 milliamperes of current will pass, so that the patient may be connected to the terminals without any appreciable shock.

Liquid rheostats have been devised for this purpose; but, although they are cheaper than those just described, they are very apt to get out of order, and seldom can be regulated through the necessary range. They are thus very unsatisfactory. Rheostats consisting of graduated coils of wire, which can be switched in or out of the circuit, have been employed; they are costly, and they are also unsatisfactory, because the passage from one coil to another means a more or less abrupt drop in the resistance with a corresponding abrupt rise in the current. The patient is thus subjected to a series of unpleasant shocks, and this defect alone is enough to condemn them.

*The Galvanometer.* — A galvanometer calibrated to read directly in milliamperes (hence termed a milliamperè meter) is an essential part of the apparatus. These are now comparatively cheap, and are so constructed as to be readily portable. Probably the most convenient form is that made by Dr. Edelmann of Munich. These instruments are fairly accurate, wear well, and can be readily transported if need be. The best form is that in which the needle is suspended by a silk fibre; for, however satisfactory the pivoted form of magnet may be at first, it becomes less so by use on account of the blunting of the pivot by continued swinging. Edelmann's instruments are nearly dead beat, that is, after the passage of a current the needle assumes its proper position, with one or two small oscillations only. This is an undoubted advantage, as the current can be quickly adjusted and read off.

A convenient instrument sold by Mr. Schall is shown in Fig. 103. The dial of this instrument is divided into fifty divisions: with both shunts withdrawn, each division represents 0.1 m.a.; with the 10 shunt screwed in, each division represents 1 m.a.; with the 100 shunt screwed in, each division indicates 10 m.a.: thus the total range is from 0.1 m.a. to 500 m.a. For those who desire an in-

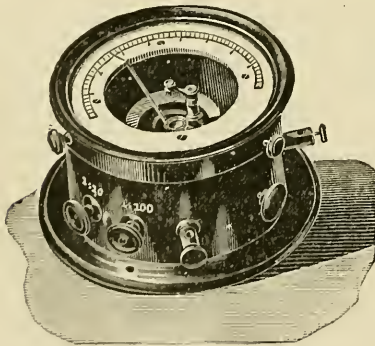

FIG. 103. — Edelmann galvanometer.

instrument of the highest class, the milliamperè meter, made specially for physicians' use by the Weston Electrical Company of America, may be strongly recommended (Fig. 104). These instruments are beautifully constructed, accurately adjusted, and absolutely dead beat. Moreover



they are quite portable, require no levelling, and seem to undergo no change by continued use; they are, however, somewhat costly. They may be obtained from Elliott Brothers, of 101 St. Martin's Lane.

When any of the swinging magnet galvanometers are used they must be set up on a level surface or adjusted by levelling screws; the instrument must then be so turned that the needle points to zero on the scale. These galvanometers should be kept as far away as possible from anything made of iron, such as a grate, stove, or iron bracket. With the Weston instrument such a precaution is unnecessary; they may be set down on any surface, and the vicinity of iron does not influence them.

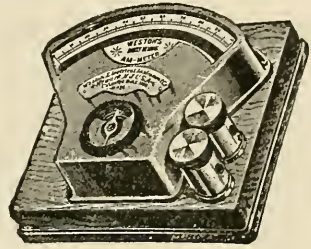

FIG. 104. — Weston milliamperè meter.

*Connecting wires* must be provided to convey the current from the battery to the patient. These may conveniently be made of copper wire (No. 18) insulated with india-rubber covered with cotton or silk; or they may be made of the stranded flexible cord used for pendant electric lights. They should be at least 4 feet in length, and of different colours, so that they can be readily distinguished.

*Electrodes.* — By electrodes we mean the special appliances by which we bring the current into contact with the patient. In gynæcological therapeutics we distinguish them by the terms internal and external, according as they are to be introduced into the interior of the body or applied to the skin. They are of course electrically distinguished by the pole with which they are connected.

Internal electrodes may be introduced into the uterus or simply into the vagina. The intra-uterine electrode usually takes the form of a sound. The most generally convenient form is one made like an ordinary uterine sound, the three or four inches at the point being made of platinum (Fig. 105). To the handle is fixed a binding screw for attachment of the flexible



FIG. 105. — Intra-uterine electrode.

conductor. A gum elastic or celluloid sheath slides on the sound and can be clamped at any point, so as to expose more or less of the platinum end. In this way a greater or a smaller part of the uterine surface is brought directly in contact with the metallic surface of the electrode, and so with the current. In certain cases, as we shall see later, the best results are obtained by limiting the area of contact to a considerable extent. For this purpose Apostoli uses electrodes having carbon ends about 0.75 inch in length (Fig. 106). By moving this along the uterine

canal successive portions may be treated at will. These electrodes are, however, straight and often difficult if not impossible to introduce. I



FIG. 106. — Apostoli's carbon electrode.

have used a sound which is about the diameter of a No. 10 bougie (Fig. 107). This is insulated up to half an inch from the point. This half inch consists of platinum of the same diameter as the rest of the sound, and is screwed to a copper rod passing down to the handle and ending in a binding screw. The position of the platinum tip can be regulated and adjusted in the uterus by means of the sliding collar which is connected to a gauge on the handle. This electrode can be readily passed into any uterus the cervical canal of which is sufficiently wide to admit it; and in the cases where the treatment is specially useful this condition is generally



FIG. 107. — Adjustable platinum electrode.

present. In cases where the cervix is so displaced by a fibroid that it cannot be reached, or in case it be impossible to introduce the sounds described, it will be necessary to puncture the tumour at its most prominent point, so as to carry the current directly into its substance; for this purpose some form of pointed electrode must be used. Apostoli recommends the use of an instrument constructed like the ordinary sound electrode, but ending in a sharp point; this is inserted into the mass for about 1 c.m., and the sheath is then pushed up to the vaginal roof. The objection to this method is that the tissue of the roof is electrolysed, and an open sinus is formed leading from the vagina to the deepest part of the puncture. This lesion is obviously not free from risk of septic infection passing from the vagina into the tissue of the tumour. A better plan is to use a needle similar to that employed for the electrolysis of aneurysms or nævi, but of course much larger (Fig. 108). The rubber insulation of this stops

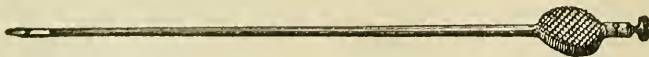

FIG. 108. — Electrode for puncture.

about  $\frac{1}{2}$  inch from the point, which is of course sharp; thus the needle can be plunged well into the tumour, the rubber sheath passing through the vaginal roof, which is thus merely punctured, not electrolysed; and on the withdrawal of the needle the puncture closes up again. The electrolysis is thus confined to the tissue of the tumour.

Vaginal electrodes may be made of plain metal bulbs carried on an insulated stem, or the bulb may be covered by a piece of cotton soaked in salt solution (Fig. 109).

*The External Electrode.* — The purpose of the external electrode is to distribute the current, as it enters or leaves the body, over as large an area of skin surface as practicable. The result is so to diminish the cutaneous resistance as to permit the passage of a current of considerable strength by means of a moderate electro-motive force; and this without the production of much pain. The main points in the selection of the electrode then are these: 1st, it must be a good conductor; 2nd, it must cover as much of the abdomen as practicable; and, 3rd, it must make good contact with the moistened skin.

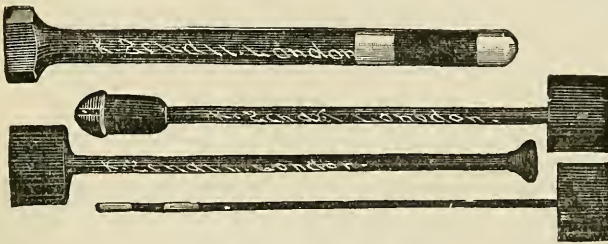

FIG. 109. — Vaginal electrodes.

The external electrode first recommended by Apostoli, and still used by him and others, is made of moistened sculptor's clay rolled into a suitable thickness, and sufficiently large to cover the greater part of the anterior abdominal wall. The clay is moistened with water and a little glycerine, and rolled to a stiff consistence with a rolling pin. It should be about half an inch in thickness, and about 10 by 8 inches in area. The clay should then be placed on a piece of muslin large enough to extend about 3 inches beyond the electrode all round; by this edge the electrode can be readily lifted and placed on the abdomen, the muslin being next the skin. A thin sheet of lead, about 6 inches square, is then placed on the clay and pressed into it, and to this one of the connecting cords is attached. The undoubted advantage of this electrode is that it forms an excellent contact with the skin, moulding itself to all the elevations and hollows, and so reducing the resistance to a minimum. It is certainly easier to transmit heavy currents by this electrode than by any other. Its disadvantages are, that in spite of every care it is troublesome to make ready, and apt to be very dirty; and as it is most effective when applied cold, it is unpleasant to the patient. If warmed it is apt to become dry on the surface, and thus to lose its efficiency. There are, however, a number of external electrodes which make good substitutes for the clay; and experience has shown that in most cases it is not necessary to employ the very high currents first recommended which can certainly be best transmitted by means of the clay. For most cases a simpler and pleasanter form of electrode

may be employed: thus a double fold of thick flannel, about 10 inches square, soaked in a warm solution of salt in water, and laid carefully on the abdomen, makes a good contact; upon this a plate of lead or zinc, about 4 inches square, should be laid, and connected by a binding screw with one of the connecting cords. A piece of mackintosh laid on the whole will prevent the moisture from escaping or wetting the dress. Again, a piece of sheet lead of sufficient size may be thickly padded with cotton wool on one side; when this is soaked in salt water it makes a good conductor, and will make close contact with the skin.

One of the best of these electrodes, according to my own experience, is supplied by Mr. Coxeter. It is made of a sheet of brass wire cloth on which a composition, consisting mainly of gelatine, has been poured. The surface of the gelatine is made very smooth. This is sponged over with plain warm water until it is slightly softened, and it is then carefully laid on the abdomen: if pressed down all round it will adhere slightly to the skin, making very intimate contact, and offering slight resistance. Currents of considerable intensity — 150 to 200 m.a. — may be transmitted by means of this electrode; and if carefully made so as to be free from air spaces, it will last for a long time. When it has become rough on the surface it may be smoothed by means of a hot knife passed carefully over it. Several other materials have been recommended, but one or other of these described will be found sufficient for all purposes.

With such an equipment the gynæcologist is in a position to make all the applications of the continuous current which experience has shown to be of practical use. It is, of course, presumed that the patients are to attend for treatment; and there can be no doubt that the best results are obtained when this can be arranged. The stationary battery can with reasonable care be relied on to do its work in a way which never can be expected from any form of portable battery, all of which are liable to disorganisation from a variety of conditions which cannot always be foreseen or provided against.

Nevertheless it may be convenient or necessary on occasion to conduct the treatment by electricity at the residence of a patient; in this case, of course, a portable battery must be employed. Hence it will be advisable to say a word or two about the most suitable instrument for this purpose. A battery of thirty or forty cells will be required. The *Léclanche* element is again the most suitable. A very convenient battery is made by Schall (Fig. 110). This contains the requisite number of elements, and is fitted with a double collector, by which not only can the cells be introduced into the circuit one by one, but any set or group of cells can be selected, so that the battery can be evenly and thus economically used. In place of the "collector" a rheostat may be used similar to the one already described. This will be found convenient, but it is more costly. A galvanometer is fitted to this instrument so that nothing in addition but the electrodes is required. Such a battery is not unduly heavy — about 38 lbs. — and is thus fairly portable. It is, how-



ever, liable to accident by careless use, and if violently jolted may be damaged by the cracking of a cell. If kept in good order it may give from sixty to seventy applications of average strength and duration, after which its electro-motive force will begin to fall and its internal resistance to rise, so that the available current will be greatly reduced. In these batteries the cells should be tested from time to time, and any defective one at once removed and replaced by another until it can be repaired. For this reason it is advisable to have a few spare cells at hand.

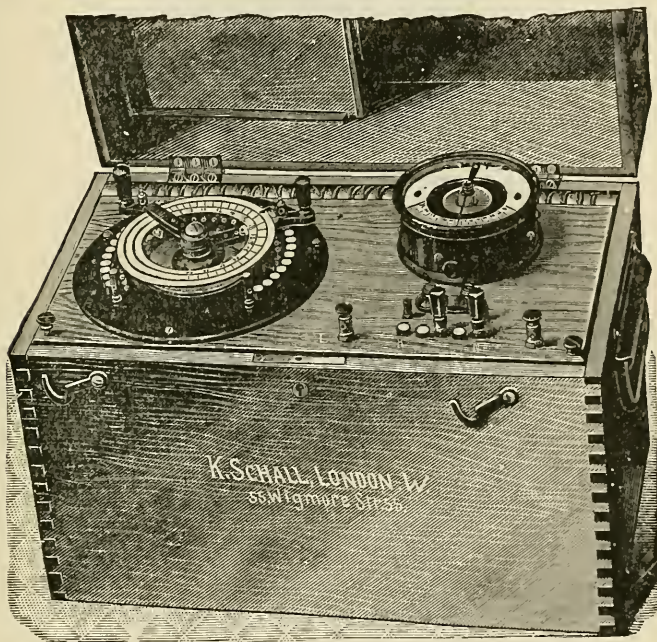

FIG. 110. — Portable battery with collector and galvanometer.

*Induced, alternating, or "faradic" currents* are frequently employed in gynecology, and for the production of these many convenient appliances are available. The most convenient portable faradic apparatus is that known as Spamer's; the whole apparatus is contained in a box 5 inches square, and includes a bichromate cell and coil with the necessary connections. For use in the consulting room Mr. Coxeter and Mr. Schall both supply very excellent coils of the Dubois Reymond pattern, which can be excited by two large Léclanche cells, or by a bichromate cell. In these the rate of interruption can be widely varied, and the strength adjusted by the sliding of the secondary on or away from the primary. It is advisable in these last patterns to have two secondary coils, one of many turns of thin wire, say 5000, and the other of a smaller number

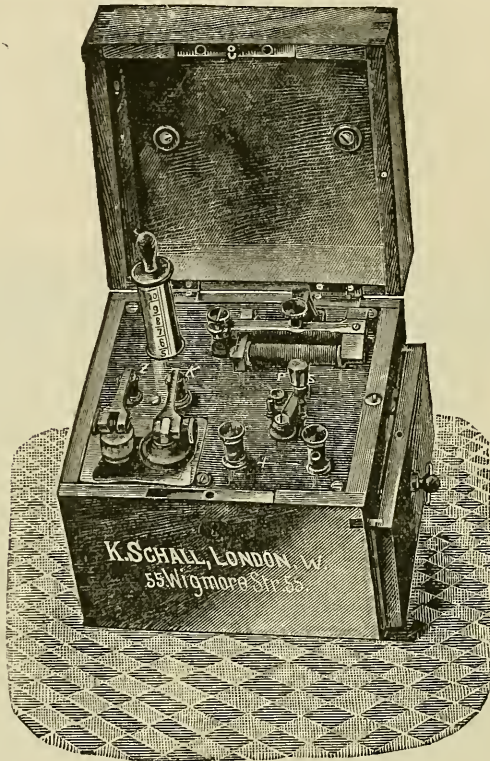

FIG. 111. — Spamer's induction coil.

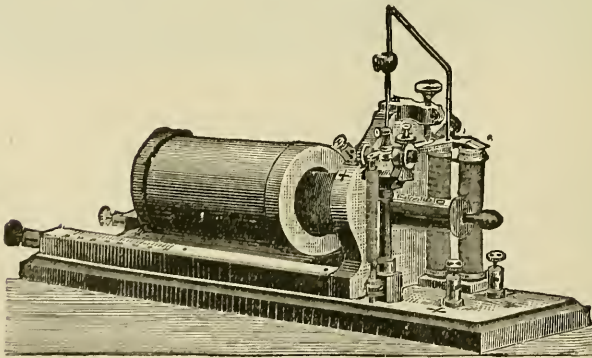

FIG. 112. — Sledge Induction coil.

of turns of thick wire, say 200. The electro-motive force of the two differs in proportion to the turns on the coil. Convenient forms of such instruments are shown in Figs. 111 and 112.

It is now necessary to consider *the way in which the pieces of apparatus described above are to be connected up for use.* We shall presume that a stationary battery of the kind described is to be employed. A level table or shelf must be provided close to the couch on which the patient is to lie. The rheostat and galvanometer are arranged on this shelf or table, and an insulated flexible wire is to be brought from, say, the positive terminal, and firmly connected to one of the binding screws of the rheostat. A similar wire is brought from the negative terminal of

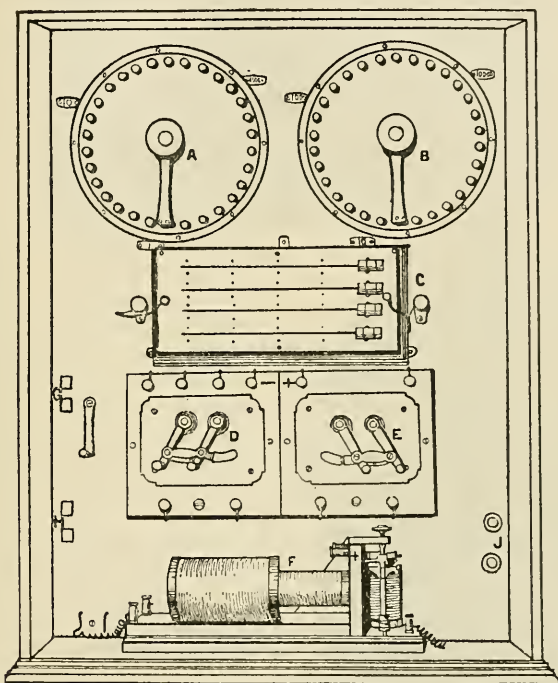

FIG. 113. — Regulator switch board for continuous and induced currents.

the battery and connected to one of the binding screws of the galvanometer. The slides of the rheostat must be so arranged that the full resistance is in circuit, while the galvanometer must be so adjusted that the needle points to zero. If it is proposed to use a current of more than 50 m.a. the 100 shunt must be screwed in; if less than 50 m.a. the 100 shunt must be withdrawn and the 10 shunt screwed in. The flexible connecting cords must then be attached to the rheostat and the galvanometer, the one attached to the former being now the positive pole, and that to the latter being the negative. These are now ready to be attached to the respective electrodes, after the latter have been adapted to the patient.



When a number of patients are under regular treatment it is advisable and most convenient to have the various instruments permanently connected up on a kind of switch board; so that, after applying the electrodes to the patient, it is only necessary to connect the electrodes to the conducting cords and turn on the current. Such an arrangement is shown in the accompanying figure, which illustrates the switch board (Fig. 113) employed by myself for a number of years, and which I have found exceedingly convenient.

As already mentioned, there is no doubt that the most convenient source of energy for electrical treatment is the lighting mains of a continuous low pressure supply. There are two ways in which the current strength may be regulated: 1st, the patient may be put in the main circuit with a resistance interpolated, sufficient to reduce the current, so that not more than one or two m.a. will pass. One hundred thousand ohms will be required to do this. The switch board shown in the preceding figure will serve the purpose very well, and another made by

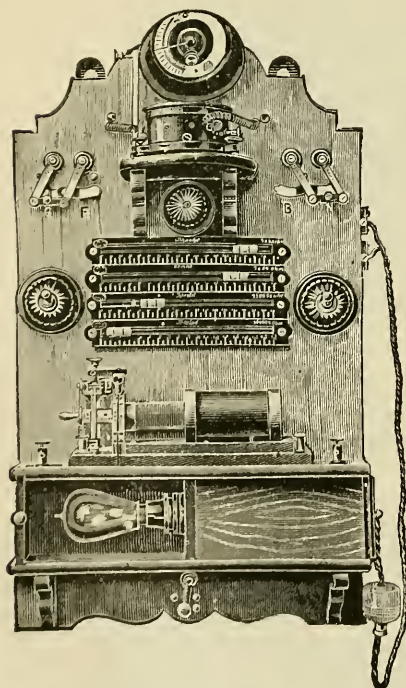

FIG. 114. — Switch board for regulating lighting currents by means of resistances.

Schall is shown in Fig. 114. The objection to this method is that at the moment of making and also at breaking contact the patient experiences a somewhat sharp and disagreeable shock, owing to the high voltage; 2nd, the patient may be in a shunt circuit. This arrangement is shown diagrammatically in Fig. 115. The current from the main passes to the resistance R. The patient is in a shunt circuit connected with one end of the resistance and the slider M. By shifting the position of the latter the voltage of this shunt circuit can be raised from 0.1 volt to 50 or 60 volts; and in this way, without shock or interruption of any kind, the current can be varied from a fraction of a milliampère to the required strength. A convenient switch board fitted on this principle by Schall is shown in Fig. 116. In all cases where current is taken from the mains an eight

or sixteen candle power lamp should be interpolated. This acts as a safety resistance, and prevents the passage of more than 250 m.a. in the former case, or 500 m.a. in the latter.



II. Mode of Making the Applications. — We may now consider the details of the procedure for administration of the current. Careful atten-

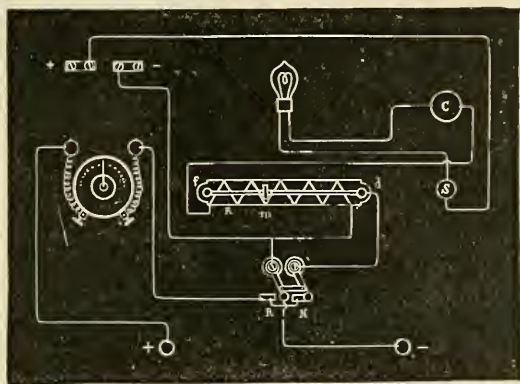

FIG. 115. — Diagram of switch board for regulating lighting currents by means of shunt.

tion to these details is essential to success and to the avoidance of serious accidents. It must be carefully kept in mind that the use of currents of 100 m.a. and upwards is not free from danger, and that serious mischief may result from carelessness in their use. The patient should be directed before attending to take a vaginal douche of warm (105° F.) water made antiseptic by carbolic acid 1-40. This should be copious, two quarts at least. On arrival she should remove her ordinary clothes, and put on a night and a dressing gown, the latter made so as to open completely down the front. She wears her stockings of course, and should also put on warm slippers. She should now lie down on the couch, which should be moderately high and firm, and should be covered with a rug or blanket. In cold weather her feet should rest on a hot water bottle.

Let us suppose that a continuous current is to be applied to the interior of the uterus for the treatment of hæmorrhage, endometritis, and so forth. A suitable sound-electrode having been chosen, it must now be passed into the uterus. This may be done with the patient on her back: if, however, as is usual in this country, the gynaecologist

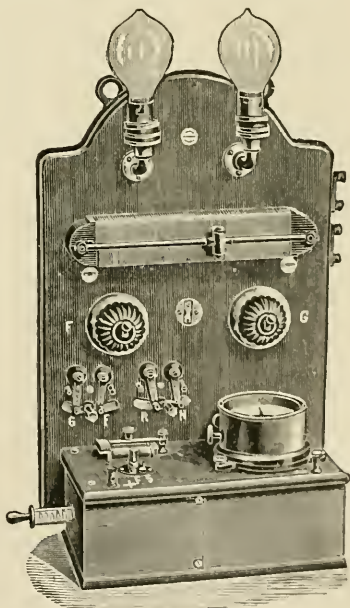

FIG. 116. — Switch board for shunt regulation.

is in the habit of passing the sound with the patient on her left side, there is no reason why this position should not be retained. When the sound is passed the finger is still kept against the cervix in order to keep the sound in position, and the patient is asked to roll slowly round on to her back, and while she is doing this care must be taken that the sound does not slip. When the patient is comfortably settled on her back the connecting cord from the proper pole must be attached, and the handle of the sound given to the nurse or attendant whose duty it is to be by the side of the couch, and to hold the sound steadily all through the sitting. The dressing-gown is now to be opened, and the night-gown drawn up so as to expose the abdomen up to the pit of the stomach. The abdomen should be sponged with warm salt solution, and any abrasion, scratch, or pimple must be protected by a small piece of pink mackintosh or oiled silk. The properly prepared electrode, whether clay, flannel, or gelatine, is now to be carefully laid on the abdominal surface so that, in the case of flannel, there are no creases, and that no part of it rests on the bony edge of the ilium. The pad must then be pressed firmly down, the connection to the other electrode made, and the blanket drawn up over the body. The patient is then requested to place both hands on the pad, and to press evenly and gently, so as to ensure good contact. The galvanometer will now indicate 2 to 5 m.a. according to the electromotive force of the battery and the resistance of the rheostat. This current is of course not appreciable by the patient. The various binding screws should now be examined and tested to make certain of their being firmly adjusted. The slide of the highest rheostat is now slowly moved so as to reduce the resistance, the patient's face and the galvanometer being carefully watched. Then the next slide is even more slowly moved, and, if need be, the third, until the limit of tolerance is reached, or until the galvanometer shows that the necessary current strength is passing. If great pain is complained of before this degree is reached, inquiry should be made if it is general all under the pad, or concentrated at one or more points. If the former, the current should be reduced for a little, when it will generally be found that the sensation of burning disappears, and the current may again be gradually increased. If the pain be confined to one or more spots it is probably due to some tender area of skin, or to some irregularity in the application of the pad; in this case the current must be reduced by introducing the full resistance of the rheostat, and the pad removed and examined. A particle of salt which has escaped solution may be the cause of very severe local pain. If this be overlooked, and the current kept on, a small but very painful ulcer may be formed, which will take months to heal. The duration of the application is reckoned from the moment at which the proper current strength is attained: it is generally continued for 5 to 10 minutes. At the conclusion of this time the current is to be gradually and slowly reduced, beginning with the lowest slide of the rheostat, and ending with the highest. When the full resistance has been introduced the internal electrode should be withdrawn, and the pad removed from the abdomen,

which is sponged with warm water and dried. The patient should then remain lying on this or another couch for a quarter of an hour: after this she should put on her clothes. It is well to advise patients, after the first few applications, to keep to a couch for the rest of the day; and also on any other occasion, if any pain or red discharge follow the application, she should be advised to go to bed, or at least to lie down for the evening. It is also very important that in the course of an hour or two after each application the vagina should be douched with carbolic lotion. When puncture of a fibroid tumour or of an inflammatory deposit has been practised special precautions are necessary. These will be discussed later.

**III. The Mode of Action of the Continuous Current.**—It will now be convenient to consider shortly the effects on the tissues produced by the transmissions of continuous currents through them by means of metallic electrodes. This will be best understood if we study, in the first place, the effect of the passage of the current through a piece of dead tissue—say a piece of beef. A small block of fresh beef is placed on a dish, and into it two steel sewing needles are inserted at a distance of an inch from each other. One of these is connected to the positive and the other to the negative pole of a battery, and a current of, say, 50 m.a. is transmitted. The following things will be observed: 1st, in a few seconds a frothy effervescence will appear round the negative needle, while the tissue will shrink and condense round the positive needle; 2nd, if, at the end of a few minutes, the negative needle be gently pulled, it will come away without difficulty, leaving an aperture a good deal wider than its own thickness. This aperture opens into a sinus which is filled with a soft frothy seum; 3rd, if the positive needle be similarly pulled, it will not come away without considerable traction, and will leave a small orifice with a dense, firm outline. 4th, On examination the negative needle will be found quite bright, while the positive needle will be dulled and slightly corroded; 5th, if the piece of meat be now carefully cut open, so as to expose the channels formed by the needles, it will be found that the track of the negative needle is surrounded by a softened loose area of disorganised tissue, while the tract of the positive is surrounded by a condensed area much smaller than that round the negative needle, it is, moreover, paler in colour, and cuts with a somewhat gritty sensation; 6th, if the surfaces so exposed are tested with litmus paper, it will be found that on the negative side an alkaline, and on the positive side an acid reaction is given.

Similar phenomena are seen as the result of the action of such a current on the albumin of an egg. If the whites of two eggs be placed in a glass beaker, and a current of 20–30 m.a. be passed through them by means of steel needles, a loose flocculent coagulum will form round the negative needle. After a time this disintegrates and floats through the rest of the fluid, leaving the needle quite clean and bright. Round the positive needle a dense compact clot is formed which firmly adheres to it, and can be lifted out of the vessel by means of it.



On examination by test-paper the positive clot will be found markedly acid, and the negative markedly alkaline.

These changes constitute part of the phenomena of electrolysis; and experiment has shown that under similar conditions identical results are produced in the tissues of the living body. Briefly stated, we find then that round the metallic surface of the negative pole *physical disintegration of tissue results with a chemical alkaline reaction*, while round the positive pole *a physical condensation of tissue results with a chemical acid reaction*.

So far as the quantitative aspects of the case are concerned we must keep in mind that the amount of tissue broken up at the two poles is, chemically speaking, identical. The basic products set free at the negative are chemically equivalent to the acid products set free at the positive electrode.

In the present state of our knowledge it is impossible to state precisely the chemical nature of the products of electrolytic decomposition at either pole: they are highly complex. Among them, however, we may readily detect a certain amount of caustic soda and potash at the negative, and of chlorine at the positive pole. To what extent the influence of these chemical substances may be credited with the production of the peculiar coagula found at the respective poles is a matter of some doubt, in spite of the fact that Apostoli and his immediate followers hold that they explain the wide difference of the condition of the tissues observed. On this account Apostoli terms the action of the positive pole "acid galvano-caustic"; and of the negative "alkaline galvano-caustic." Our ignorance of the precise nature of the chemical and vital changes induced by electrolysis of these complex bodies scarcely justifies this assumption; and further investigation is necessary to explain the marked difference between the influence of these poles.

It seems safer in the meantime to accept simply that the difference in the action exists; and, in cases where we seem to require a loose disintegration of tissue, to employ the negative pole; and in others, where we seem to require an "astringent" or condensing effect, to resort to the positive pole. In other words, it is better at present in our employment of these currents to trust to an empirical knowledge of the effects produced, than to attempt to guide our methods by an assumed knowledge of the way in which those effects are produced.

In addition to the electrolytic effect another influence of the continuous current is claimed by certain authors; this is termed the "interpolar effect." By this is meant an assumed influence of the current upon the tissues lying between the electrodes. It is practically assumed that the passage of the current produces a certain influence, disintegrating or otherwise, upon the molecules of the tissue which lie in its path between one electrode and another. To this supposed interpolar effect is attributed a great part of the diminution in the bulk of fibroid tumours and celluitic deposits which is occasionally met with in our experience. Now, it is admitted that there is no physical evidence for the decomposition of the solution of a salt by a galvanic current save in



the vicinity of the electrodes. The products of the decomposition appear round the electrodes, and so far as any direct evidence is concerned there is no proof that any change occurs in the fluids between these regions. Still less is there any evidence that electrolytic decomposition takes place in such a mass as that of a fibroid tumour away from the seat of the electrodes in contact with it. Any so-called experimental proof which has been advanced in favour of the existence of inter-polar decomposition can be readily explained on other grounds; and we may take it that there is no proof of any electrolytic decomposition occurring anywhere except round the metallic electrodes.

There is abundant clinical evidence, however, that the passage of a current through the pelvis may have other than directly electrolytic effects. For example, it is a matter of common experience that, after two or three applications of a fairly powerful current to a uterine fibroid, the bulk of it will be appreciably diminished. This immediate, but in many cases temporary effect is oftenest produced when the positive pole is applied to the interior of the uterus; and it appears to be due to a stimulation of the muscular fibres of the uterus and tumour by the current, which results in a vigorous contraction and expulsion of a large amount of the blood contained in these structures, and a consequent diminution of their bulk. That this may have an important effect on the nutrition and growth of such a tumour seems very likely, and that its repeated reproduction may ultimately induce a progressive atrophy of such a neoplasm is no less probable. That this is the action of the current in many of these cases is also borne out by the fact that bulky and somewhat soft fibroids, after a few applications, often show a marked diminution in bulk; while at the same time they become firm and condensed to external manipulation. Further, during this process of shrinkage, we may notice that large quantities of watery discharge are constantly escaping from the uterine cavity.

A second effect, which one may often observe in cases under treatment, is the production of a sense of improved well-being which frequently is felt almost from the first. Every one, who has had an experience of any extent in the treatment of pelvic diseases by electricity, must have noticed how often the patient expresses herself as greatly benefited by the treatment long before any definite change can be detected in the local condition. So manifest and constant is this effect, that it would almost appear that these electric currents in some way induce an improved nutrition and a general exaltation of function in which the nervous system especially participates.

**IV. The therapeutic application of electricity,** to those diseases of the female pelvic organs in which experience has shown that beneficial results have followed its use, is now to be considered.

*Stenosis.* — A contracted state of the os externum or of the cervical canal, whether congenital or acquired, can be successfully treated by electricity. The symptoms associated with this condition are usually dysmenorrhœa and sterility. In congenital conditions there is often,

though by no means always, an imperfect development of the uterus and ovaries; and in these cases, of course, the main object is to relieve the dysmenorrhœa. These conditions can no doubt be treated in most cases by dilatation on one or other of the well-known methods. This, to be satisfactory, involves the use of an anæsthetic, for when the dilatation is carried to the necessary extent the pain produced is very great. Further, it is a matter of common experience that there is a tendency for the pain to recur after several months of painless menstruation; so that, in order to relieve the menstrual pain, the repetition of the operation to a certain degree is required from time to time.

Considerable experience with both methods seems, however, to show a distinct advantage in favour of the electrical treatment for these conditions. This treatment is practically painless; it involves no interference with ordinary duties or occupations, and its results in my experience have been more permanent and more completely satisfactory than those of forcible dilatation.

The mode of treatment is as follows:—The ordinary platinum sound is employed as the internal electrode. With a little care this can be introduced into the canal without any previous dilatation; but, if need be, a No. 1 or No. 2 Hegar dilator may be passed first.

The sheath is carefully pushed up against the os, and this electrode is connected to the negative pole; the abdominal pad is now applied and connected to the positive pole, and a current of from 50 to 80 m.a. is slowly turned on. This should be continued for five minutes, and then taken off gradually. This application should be made twice a week for eight or ten times. Unless an application takes place very near the expected time of menstruation there is no need of any special restriction on the patient's movements. If it happens within a day or two of the menstrual onset she should rest for some time afterwards.

After two or three sittings it will be found that the canal is much more patent. It is advisable then to employ the thick sound, taking care always that it is not inserted too far into the cavity; its point should just pass through the os internum.

The relief given to the dysmenorrhœa is almost always immediate; if only two or three applications have been made before a period sets in this period will be almost painless. As a rule ten applications of the strength indicated are enough. When the cervix is at first very sensitive, owing to the presence of an endocervicitis or an endometritis, the patient may not be able to bear such current strengths; in these cases it is better to begin with the use of the anode internally, using a current strength well within toleration. After a few applications it will be found that the full kathodal strength can be used without inconvenience.

*Endometritis.*—The great majority of cases of chronic endometritis undoubtedly yield to the various means, other than electrical, at the disposal of the gynæcologist. These have the advantage of occupying less time, a matter of considerable importance to many patients. The

simpler measures, such as the application of caustics like carbolic acid or iodine, to the endometrium, if done with reasonable skill and care, are practically devoid of danger. But it is only in the milder cases that we can expect such measures to effect a cure. The more efficient and more drastic procedure of curettage is now found necessary in a large number of cases; and it is useless to deny that this method, even in experienced hands, is associated with very considerable danger: the danger may be minimised by skill and care, but it cannot be entirely eliminated. It is, accordingly, as an alternative to curettage that the advantage of electrical treatment appears; for, with the simplest precautions, this method is free from danger. Not only so, but the experience of a very considerable number of cases has shown that it will often cure when repeated curetting has failed to produce any permanent benefit. I am convinced that electrical treatment will cure any case curable by curetting, and will also cure many cases that curetting cannot cure. Against the length of time that it occupies we may confidently put the entire freedom from danger. Still, I do not advocate its use in all cases of endometritis. The time occupied by it, which is not less than two and often as long as three or four months, is a serious difficulty, and one which renders the method impracticable for a considerable number of patients. In the simpler and more recent cases the cauterisation of the endometrium is easy and effective; in the more chronic and persistent cases I should certainly advise thorough curetting. If this is to be effective the result will show itself in a short time; but if not, and if any of the symptoms return, I do not hesitate to advise electrical treatment as being much more likely to produce a permanent cure than any number of subsequent applications of the curette.

The symptoms of chronic endometritis are chiefly leucorrhœa, hæmorrhage, and local discomfort; and the predominance of one or other of these in any given case forms a sound guide to the proper mode of electrical treatment.

Without going into a detailed consideration of the pathological changes in the endometrium in the various kinds of this disorder, it may be advisable to recall the fact that, in the glandular variety, we have a characteristic increase of the gland elements of the endometrium, accompanied by thickening of the whole membrane, and characterised by a more or less profuse flow of a discharge which may be watery, creamy, or greenish: in the hæmorrhagic variety the membrane is greatly thickened, thrown into elevations, and especially characterised by a great increase of the vascular constituents of the structure. A third variety, characterised by a profuse flow of muco-pus, is distinguished by the development of granulations composed of an embryonic tissue. This last variety seems to be somewhat rare; the great majority of the cases fall in the first two classes. It should be kept in mind that practically in every case of endometritis the uterus is enlarged; the tissues of the wall seem swollen, soft, and boggy, and the organ is usually mobile, readily falling to one or other side of the pelvis with the inclination of the body.

Very often the os is patulous; this is generally the case with the os



externum, but in a certain number of cases the os internum is not larger than usual, and admits nothing thicker than the ordinary sound without being stretched.

The amount and kind of the pelvic distress are very variable. In some cases there may be little or none; in others there may be more or less constant discomfort, amounting at times to severe pelvic pain. In most there is an unpleasant backache or feeling of weariness and fatigue which greatly interferes with the performance of ordinary duties.

The details of the treatment of chronic endometritis vary with the nature of the conditions to be dealt with. Attention must be given to the special symptoms present in each case; as we have seen these are generally pain, leucorrhœa, and hæmorrhage. It is generally laid down as a guiding rule that if hæmorrhage be a prominent feature the positive pole should be used internally, and when this is not the case that the internal electrode should be negative. There seems no doubt at all as to the propriety of the use of the positive pole in hæmorrhagic cases; the "astringent" and hæmostatic influence of it is well known, and the results on the first menstrual period after the beginning of treatment are usually very striking. Not only does it seem effectually to destroy the hæmorrhagic endometrium, but it seems in a very definite way to diminish the bulk of the whole organ, during and for some time after each application; as if it caused an emptying of the distended vessels in its walls. On the other hand, the wisdom of the routine use of the negative pole internally, in all cases of a marked leucorrhœal type, is by no means so evident. In these cases the endometrium is no doubt thickened by an increase of the glandular or connective tissue elements of the structure, and accordingly the negative pole is employed on account of its supposed destructive action on the tissues. It is assumed, in fact, that "electrical curettage" is more effectually performed by the negative pole. This, however, is by no means clearly proved. No doubt the electrolytic results of the kathode are more bulky, because more loosely held together; but the actual amount of tissue destroyed is not necessarily greater. The affected area round the anode seems less than that around the kathode, because the affected tissue in the former case shrinks more than in the latter; but the tissue round the anode is as thoroughly devitalised as that round the kathode. As a matter of fact the influence of both poles is, chemically and quantitatively speaking, equivalent; but the anodal application has this advantage over the kathodal, that it tends most effectively to restrain hæmorrhage. The destruction of the diseased endometrium must often result in the exposure of a more or less vascular surface. Every one knows how some of these leucorrhœal wombs bleed during the use of an ordinary curette. Accordingly, after the use of the negative electrode it is not uncommon to find patients losing blood for some days in greater or less amount; and if a period comes on after but one or two applications the menorrhagia is often considerable, and this in patients in whom hæmorrhage had not previously been a prominent symptom. Now with the anode used internally this is very seldom the case. As a rule in



these cases there is a little red or reddish discharge on the evening of the sitting, or perhaps for an hour or two next day; but the quantity is inconsiderable, and never amounts to hæmorrhage. When I first began to employ electricity for the treatment of endometritis I always employed the negative pole; and to combat the hæmorrhage, used to enjoin on the patient the necessity of going to bed and using a hot douche, or taking some ergot every day while the early part of the treatment lasted: but in spite of this the exhaustion of the patient by persistent blood loss was a serious matter. Such complications are entirely avoided by the use of the anode.

Moreover, the anode has another advantage in the treatment of these cases. A painful condition of the pelvic organs constitutes a marked feature in many cases of endometritis, which pain may be due to the inflamed state of the uterus or to altered conditions of the tubes, ovaries, peritoneum, or parts around; in these cases the negative pole is very badly borne. The kathode, when applied to normal surfaces such as the healthy skin, is far more irritating to sensory nerves than the anode. This sensory effect is greatly exaggerated in inflamed structures, and accordingly it is difficult or impossible for many patients to tolerate a current of sufficient strength for any length of time if the kathode is used internally. On these grounds, then, I should strongly advise that, in all cases of endometritis, whatever the prominent symptoms may be, the internal pole should be anodal, at any rate at the commencement of treatment. In this way hæmorrhage will be checked, and larger and therefore more efficient currents will be more easily borne.

The mode of making the application does not materially differ from that of which a general description has been already given. One or two points, however, require notice. For the first four or five applications it is advisable to employ the ordinary platinum sound-electrode, exposing as much of the metal as corresponds to the length of the uterine canal. In this way the whole cavity is brought under the influence of the current. The handle of the sound may be moved slightly now and then during the sitting in order to bring the platinum in contact with different parts of the endometrium. After four or five applications have been made by this instrument the thick, short platinum sound, or Apostoli's carbon electrode should be used, the active part being shifted down the cavity length by length, either at each sitting or on consecutive sittings. In this way the current density is greatly increased, and is brought to bear on each segment of the cavity in succession.

A very careful preliminary bimanual examination should be made in order to determine the exact position of the os and the lie of the uterine body; and in passing the electrode the greatest care should be exercised so as to excite as little pain as possible. If pain be caused at this stage it will seriously interfere with the toleration of a suitable current strength. When the sound is fully introduced the sheath should be pushed well up into the cervix to protect it from the action of the current: the cervix is sometimes highly sensitive, and it is better, at first

at any rate, to concentrate the action on the endometrium proper. When the sound is properly placed and connected, the application of the abdominal pad requires some attention. It should be large so as to diminish the skin resistance as much as possible: if, however, it is known that one ovary is inflamed, or that one side of the pelvis is more sensitive than another, the pad must be shaped so as to avoid this region. To do this, and yet to obtain a sufficient surface, it may be advisable to shift the pad well on to the epigastrium, or as high up on the thorax as the mammæ will permit. Some have recommended that the pad be placed on the back, or that an auxiliary pad be used there; but it is difficult to get good contact on the back with the patient in the dorsal position, and a little management will enable us to get all the surface we want on the anterior aspect of the body. The current employed should be moderate at first; if 50 m.a. can be borne on the first occasion we should rest content. This may be kept up for eight minutes or so and then gradually reduced. On subsequent occasions the current must be increased; this can be done without difficulty if care be taken, until by the eighth or ninth sitting as much as 150 or 170 m.a. can be borne. I am of opinion that in this group of cases a much stronger current is required than in some other groups—bleeding fibroids, for example. To judge from the recent writings on this subject, most operators have abandoned the use of the very powerful currents—250 m.a. and upwards—first recommended by Apostoli; and in this decision I quite agree with them. But, while excellent results can be obtained in the treatment of bleeding fibroids by the use of currents of only 100 m.a. or even less, I believe the best results in cases of endometritis, whether hæmorrhagic or leucorrhœal, can be got only by the use of currents a good deal stronger than this. Hence the importance of taking all the precautions possible to favour the toleration of a high current,—these being, as I have said, the use of the anode, great care in introducing the sound, the protection of the cervix, and the proper application of the external electrode. A douche, both before and after the application, must be insisted on; and if pain persist the patient should go to bed and repeat the douche (at 105°) in the course of the evening. If there be no pain the avoidance of any undue exertion is all that need be exacted. The application should be made twice a week. The first three days of the menses should be avoided, but after that treatment should be resumed. As to the number of applications required much will depend on the circumstances of each case. If the patient is regular in attendance and can bear a medium current, fifteen to twenty-five sittings will suffice; but more will be required in cases where these conditions cannot be obtained. After twenty-five applications have been made it is advisable to stop for a month, watching the symptoms; if they seem then to increase a few more applications should be made, but I have not met with any case in which twenty-five consecutive applications of average strength failed to effect a cure. In cases in which pain is a prominent feature, and in which the pain is increased by the application of the continuous current, and continues

for some time afterwards, great advantage will be gained by the use of the "faradic" or induced current. This application is made as follows:—the continuous current having been applied, as above directed, to the full tolerance of the patient for, say five or six minutes, the current is slowly reduced, and when zero has been reached, the electrodes are connected to the terminals of the secondary coil, which should have as many turns as are available. The hammer should be set to give the most rapid interruptions possible. The apparatus is started with the current at its weakest, and gradually increased until the patient begins to feel a sensation of numbness in the pelvis; after which time it may be continued for three or four minutes and then stopped. In most cases this completely removes any pain which may have been caused by the continuous current.

During a course of treatment such as this the patient should be advised as to the regulation of her diet and the action of the bowels; and she should be encouraged in the use of reasonable exercise. As was previously noticed, nothing is more remarkable in these cases than the almost immediate effect this treatment seems to have on the general well-being of the patient. From the first the sense of depression, which is so common in this disorder, begins to lighten. Exercise becomes less and less a burden, appetite and circulation manifestly improve, and the bowels either begin to act regularly and spontaneously, or do so under much less artificial stimuli than they have previously required. This sense of improvement greatly lightens the tedium of the treatment, encourages the patient, and enables her to tolerate increasing and hence more effective current strengths.

One word by way of caution. During the whole course of treatment, but especially towards the end of it, sexual intercourse must be forbidden. As the patient improves conception may occur, say after a menstrual period, during and subsequent to which there may, for some reason, have been a somewhat longer cessation of the applications than usual. When these are resumed it is more than likely that abortion may be induced by the first application of the current. I have in my records two cases where profuse and persistent hæmorrhage, which I can account for in no other way, followed an application. Indeed in one case decidual shreds came away for a long time afterwards. In this case, owing to special circumstances, the application had been in abeyance for nearly a month.

*Subinvolution.*—A group of cases in which excellent results are obtained by the use of electricity are those in which, after a comparatively recent pregnancy, the normal involution of the uterus has, by some cause or other, been checked, and it remains large, congested, and soft. This is, of course, most frequently seen after neglected or badly managed abortions occurring in the early months; and the condition is one which, as every gynæcologist well knows, is often the precursor of a whole train of morbid phenomena, organic as well as functional. Let us take a typical case: an abortion has occurred at, say, the third or fourth



month; a few days afterwards the patient gets up, the hæmorrhage having barely ceased; the next period comes on in about three weeks, and is so profuse that the woman may be compelled to return to bed for a while; the hæmorrhage ceases, she resumes her duties with the same result—a premature and profuse menstruation. Such a condition as this may continue for some months, the patient suffering seriously from the losses, from an intermenstrual leucorrhœal discharge, and from constant and increasing pelvic distress. If the patient now comes under observation we find a large, soft uterus, often retroflexed and retroverted, with a patulous os and some tenderness on pressure. The sound may pass  $3\frac{1}{2}$  to 5 inches, and it is felt also that the walls are considerably thickened. With every care it may be impossible to avoid producing some hæmorrhage on passing the sound. The uterus may be found tender, and not unfrequently the ovary on one or other side is prolapsed. Usually the rectum is loaded, or at any rate large doses of purgatives are required to produce an evacuation. We have to deal here with the first or congestive stage of a chronic metritis, which may be associated ultimately with the local and general conditions only too familiar to us in such cases. No doubt this condition is amenable to ordinary modes of treatment, but to nothing does it yield so thoroughly and so expeditiously as, in my experience, it has done to electrical treatment.

The treatment may best be begun by a few applications of the induced current. For this purpose Apostoli's bipola intra-uterine electrode, or the ordinary sound-electrode, and a small abdominal pad may be used. The coil, with somewhat slow interruptions, is connected, and a current as strong as can be borne is applied for ten or fifteen minutes. This may be repeated three or four times a week for a fortnight or three weeks. The effect of this seems to be to increase the tone of the uterine muscle, and materially to diminish the congestion. At the end of this time it will be found that, although the cavity is not appreciably shortened, the walls are less flabby, certainly less thick and swollen; and there is far less tendency to backward flexion. The general feeling of pelvic distress is also greatly relieved. The application of the continuous current may now be commenced. Here again the anode is used internally, the full length of the platinum electrode being employed, and the treatment carried out in the way indicated for endometritis. Smaller currents up to 100 m.a. will suffice. After ten or twelve applications the uterus will be found markedly diminished in length, the white discharge almost gone, and the periods normal in amount and duration. Fifteen to twenty applications will be sufficient. If at the end of this time there be any tendency to displacement, a pessary should be fitted and worn for a few weeks. The same precaution as to the avoidance of a risk of conception must be insisted on as in the treatment of endometritis.

*Fibroid Tumours of the Uterus.*—The great interest which in recent years has been aroused in the application of electricity to the treatment of pelvic diseases in women is undoubtedly due to the work of Apostoli



of Paris ; it began when the account of his results in the treatment of fibroid tumours was published in 1886. His methods were a complete departure from anything which had been attempted previously, and the results were in themselves so striking that attention was at once arrested. To him, then, is due any credit which is associated with this form of treatment. No doubt a considerable number of attempts had been made to utilise this form of energy for the purpose of treating various forms of gynæcological diseases by previous workers, but the methods were crude and the results insignificant. A strong claim of precedence was made by Cutter, and by others on his behalf, in America ; but it has been shown again and again that the apparatus used by Cutter was quite incapable of giving anything like an appreciable current, and that the effects produced must have been due to other than electrical agency. Apostoli's position rests on the fact that he employed strong currents which were accurately measured, and which were applied on a definite principle, depending on the characteristic action of the different poles. He certainly was the first to show how the currents might be obtained, how they should be measured, and especially how they could be brought to bear on the tissues to be dealt with. Until he did it no current approaching 200 m.a. had ever been transmitted through the human body for therapeutic purposes ; he showed very clearly how this could be done, and he also demonstrated, to a great extent, the result of such an application. Apostoli's communication aroused great interest all over the world, and very speedily a number of gynæcologists were engaged in an extensive series of clinical experiments to verify or disprove the results alleged by the originator of the treatment. Many of these experiments were of the crudest kind, and in some cases were attempted by men who knew little or nothing of the nature of the energy they were endeavouring to use, and with apparatus quite incapable of providing or applying that energy. Not only so, but Apostoli's statements were misread, and he was credited with alleging results which he never did allege. Because he said that some tumours diminished or disappeared, it seemed to be assumed by some of his critics that all tumours should disappear under this form of treatment ; and as they did not do so his assertions were regarded as unfounded. It is probable, too, that a misapprehension of the scope of the treatment arose from the unreasonable claims which were made for it by some of its upholders ; thus again a certain disappointment and sense of failure arose in the minds of those who were endeavouring to obtain results which should never have been claimed. For a time the discussion was keen, not to say acrimonious ; and extreme opinions were freely expressed. Time has allayed the turmoil of the debate, and the method, if practised by a smaller number, is receiving a fairer trial and is being placed on a sounder basis. "Apostoli's method" is now generally regarded by those who have given it a fair and intelligent trial as fulfilling a certain well-defined, but highly important function in gynæcological therapeutics ; and those who have not given it such a trial have no right to an opinion one way or the other.

The symptoms arising from the presence of a fibroid tumour of the uterus are the following:—(i) Hæmorrhage; (ii) Pain; (iii) Pressure symptoms. These may, however, be entirely absent in some cases of fibroids even of considerable size. On the other hand, they are often all present together in one subject.

The cause of the hæmorrhage is undoubtedly the great vascularity induced by the growth; and the blood seems to come not only from that portion of the mucous membrane which lies on the surface of the neoplasm, but from the whole endometrium as well. It may show itself at the menstrual periods only, or it may occur also during the intermenstrual time. The pain may arise from various causes. It may be due to the growing fibroid pressing upon and straining the uterine nerves, to irregular uterine contractions set up by the presence of the tumour, to the production or straining of peritoneal adhesions, and to the compression of nerves with which it comes into contact.

The pressure symptoms chiefly affect the bladder and rectum, and often disturb their functions to a very great extent. They may also act on the pelvic veins, causing hæmorrhoids and varicose veins of the lower limbs. In large tumours the effect of pressure may manifest itself on organs so remote from the pelvis as the stomach and heart. The most acute form of pressure effect is seen in the case of growing fibroids which have become incarcerated in the pelvis. In these cases the suffering at times becomes intense.

To the relief of these symptoms, pain, hæmorrhage, and pressure, the electric treatment of fibroids is directed. If it succeeds in relieving these it not only removes the danger of death (which, though comparatively rare from a fibroid tumour, yet may result from sudden or continuous hæmorrhage, or from gangrene during spontaneous enucleation), but it also removes or greatly ameliorates all those consequences of the presence of the tumour which tend to interfere with the discharge of ordinary duties, and in many cases render life a daily increasing burden. The aim of the gynæcologist is not to remove the tumour, nor greatly to diminish its bulk; it is simply to abolish those conditions which impair the activity of the subject of it, render her life a burden, or even menace her existence.

It is to this relief of the symptoms of fibroid tumours that those who have systematically and carefully carried out Apostoli's method are prepared to lay claim; and when we consider that, in the great majority of cases of this exceedingly common disorder, these symptoms are the only serious ones, it must be admitted that the claim is no insignificant one.

I repeat it is not alleged that tumours are necessarily dispersed or materially diminished in bulk by electrical treatment, however long or energetically carried out; that both these events happen from time to time is no doubt true, but the symptomatic cure which is claimed as the aim and result of this treatment does not depend on the disappearance or even on a considerable diminution of the tumour. To those who have had even a moderate experience of this method, it is known that a

tumour which was a menace to life may cease to give any inconvenience without undergoing any appreciable diminution in size.

The question, then, naturally arises how these symptomatic ameliorations are brought about? How are the hæmorrhage, the dysmenorrhœa, and the general pelvic distress relieved by electrical treatment? The answer to this question is by no means clear. That the results are such as I have stated is certain; the explanation of the results is a matter of some doubt. One or two considerations may, however, help to throw light on this subject: first, as regards the arrest of hæmorrhage, we know that the source of it is the congested endometrium; we have seen that electricity will cure ordinary hæmorrhagic endometritis, and it is not unlikely that if a fibroid be present in the uterus the endometrium is in a state not unlike that found in endometritis. It is probable, then, that the action of the intra-uterine pole is such as to change the state of the endometrium and so to diminish its tendency to bleed. But it is not always necessary, in order to produce this control of hæmorrhage, that the metallic electrode should come in contact with the endometrium. There are some cases of hæmorrhagic fibroid in which, on account of the displacement of the uterus, it is impossible to introduce a sound. In these cases electro-puncture of the projecting mass of the fibroid may be resorted to; and though, in such a case, the endometrium is never reached, the hæmorrhage comes very soon under control. This clearly shows that, while electrolytic effects on the mucous membrane may be part of the explanation of electro-hæmostasis, it is not the whole explanation. Other and more obscure effects of the electric application must play an important part in the process. One of these effects seems to be the distinct, though limited and probably temporary, shrinkage of the tumour, which is probably due to the stimulation of the muscular tissue of the uterus and tumour; for there seems no doubt that those tumours which contain most muscular tissue are most susceptible to treatment. This shrinkage can be inferred from these two facts: firstly, after a sitting in which the positive pole has been used, bimanual examination will give a distinct impression that the tumour has become more firm and condensed than before; and, secondly, in cases of tumour threatening impaction, although before a sitting it may often be found quite impossible to raise the mass out of the pelvis, or even to shift its position, and that the attempt to do so causes intense pain, yet immediately after the sitting it can be pushed well up into the abdomen, with very little inconvenience to the patient. Such a change can only be explained by a change in the bulk of the tumour. It seems, then, quite likely that the hæmostatic effect may, to some extent at any rate, be a secondary result of muscular contraction.

It is well recognised, of course, that the continuous current has a marked effect in producing powerful contractions of the uterus. This can be demonstrated experimentally; and it is shown clinically by the considerable number of intra-uterine fibroids which have been expelled during electrical treatment, in some cases after a very few applications. It is



further quite probable that we must look to this contraction-producing effect for an explanation, not only of the hæmostatic results, but also of the alteration of nutrition and consequent diminution in size which not infrequently result from electrical treatment.

The pathology of fibroid tumours and their clinical classification have been dealt with in another part of this work.

**The indications for electrical treatment** must now be considered, and on the other hand the conditions, whether in the tumour itself or its surroundings, which forbid its use. To take the latter first, we may enumerate the following conditions:—(a) Tumours which give rise to no symptoms of hæmorrhage or pain, and which are either small enough to lie comfortably in the pelvis, or are large enough to occupy part of the abdominal cavity, are generally subserous, and in many cases are connected to the uterus by a more or less defined pedicle. Little benefit will accrue from electrical treatment in these cases, however long it may be carried out: they are best left alone. (b) Tumours belonging to the fibro-cystic type are not amenable to electrical treatment. These often grow rapidly, and are usually associated with a sero-sanguinolent discharge, often profuse in amount: it is almost universally admitted that electricity has little influence on them, and prolonged attempts may tend rather to increase the amount and frequency of the hæmorrhage. Moreover, the electrical application seems to have no influence in controlling the growth of these tumours, probably owing to their scanty and disorganised muscularity. (c) The soft, gelatine-like fibroid (the “œdematous” fibroid of Tait) has many clinical characters in common with the fibro-cystic variety. It seems in all cases to resist electrical treatment, and is indeed apt to undergo reactions of an unsatisfactory and undesirable kind on persistent attempts at treatment. (d) The presence of any degree of purulent salpingitis ought to be regarded as an absolute contra-indication. In the first place, this complication renders the tolerance of an effective current impossible; and, secondly, it has been found that even small currents (20–30 m.a.), if administered in such cases, are always followed by an increase in the local pain, sometimes by rigors and by a rise of temperature. Such sequelæ must be regarded in any case in which they occur as an absolute contra-indication. (e) A chronic peritonitis in connection with a fibroid, which has set up firm adhesions of the tumour either to the parietal peritoneum or to adjacent viscera, must be approached with much caution. It is undoubtedly a fact that some of these cases of peritoneal adhesions yield in a remarkable way to the use of electrical treatment, and in them the procedure is more than justified. In others, however, the same reactions as those noted under (d) appear, and in them further attempts must be abandoned. Accordingly, in such cases tentative measures with a very weak current at first may be tried, the results being carefully noted and subsequent procedure thereby regulated.

Turning now to the indications for the electrical treatment of uterine fibroids, we may make the general statement that all fibroids—whether submucous, interstitial, or even subperitoneal—which give rise to hæmor-



rhage or pain, which do not belong to the pathological varieties above noted, and which are not complicated with suppurative or inflammatory conditions in the uterine annexa, are fit for treatment by electricity.

It is almost unnecessary to say that no one supposes that the symptoms will be cured in every such case; but under fair and reasonable conditions the pain and hæmorrhage will be so completely relieved in the great majority of them as to remove the burden from life, and render existence not only tolerable, but enjoyable.

Of the various clinical types which yield to treatment one may single out as specially amenable submucous tumours of moderate size, of fairly soft consistency, in which growth is fairly rapid, and in which the periods and intermenstrual hæmorrhage are fairly profuse. Under this treatment the growth is distinctly arrested, the hæmorrhage is reduced to that of a normal period, the pain, if it exists, is abolished or greatly relieved, and the sense of well-being is enormously exalted. And these are just the groups of tumours, occurring as they do most frequently between the ages of thirty and forty, which, by their continued and recurring hæmorrhages, reduce activity to the lowest point, and vitality to the narrowest verge of existence.

**Method of Treatment.** — We may now consider the special details of procedure in dealing with these cases. It cannot be too strongly kept in mind that success entirely depends on close attention to these details, to the general care of the patient, and on watchfulness in regulating the manner, frequency, and vigour of the applications.

Before the sitting the patient should take a copious douche, containing boric or carbolic acid, or some other suitable antiseptic; the temperature of which should be between 115° and 120° F. The high temperature seems to check any hæmorrhage which may be going on, and also acts usefully as a stimulant. After being placed on the couch the first step should be the introduction of the sound. Apostoli and some others recommend that the abdominal pad be placed in position first, the object of this being to give it time thoroughly to saturate the skin and to get into good contact with it before the current is turned on. My objection to this, however, is that it necessitates the introduction of the sound while the patient is on her back. Most people in this country are far more expert in passing the sound with the patient on her side; and as it is of the first importance that the sound be passed with as little effort and with as little disturbance of parts as possible, it is obviously better that it should be done in that attitude in which the greatest skill and dexterity are available. Moreover, the time occupied by adapting the pad is well spent in allowing any pain set up by the introduction of the sound to subside; so that it may not in any way interfere with the tolerance of the maximum current. The introduction of the sound is a matter of varying difficulty in these cases. Sometimes it is quite simple, sometimes it is a matter of extreme difficulty, involving no little dexterity and patience. A careful bimanual examination will often help us much in indicating the relations of the uterus and tumour, and the probable lie of the uter-

ine canal. If any difficulty is anticipated it is often wisest to use first the ordinary Simpson sound, with which one is most familiar, to determine the direction of the canal and the presence of any projection which may cause difficulty. When this is withdrawn, and the various movements required to insert it are carefully borne in mind, the electric sound may often be passed with ease. The most troublesome cases are those in which the cervix is tilted very high up, either in front or behind, by the retroversion or anteversion of the tumour; and of these two the former is the more objectionable. The annoying thing about these cases is that when the tumour is moderate in size the direction of the canal varies from time to time, so that each sitting is complicated with the trouble and time spent in introducing the sound. In cases where the uterus is lying forward the tendency to shift is not so marked, and the direction once determined makes it easy to pass the electrode subsequently.

The sound having been inserted, the patient turns on her back, the sound being held with the finger in the vagina to make sure that it does not shift in any way. The close contact of the abdominal pad is quickly assured by sponging the skin of the abdomen with hot water previous to its application; and by the time it is adjusted any pain set up by the introduction of the sound has had time to subside. The current is now slowly turned on, with the precautions already indicated. At the first sitting we should be content with a current strength of 60 m.a., or even less. This is usually well borne, and the patient gains confidence by discovering that any discomfort produced is moderate and easily supported. A duration of five minutes after this current strength has been attained should suffice. The positive pole should always be employed internally; in bleeding fibroids this rule admits of no exception: the negative pole causes more pain, and is apt to be followed by free hæmorrhage. After the current is stopped, and the apparatus removed, the patient should lie down on a comfortable couch for twenty or thirty minutes; and on going home she should either go to bed at once, or keep to a couch for the rest of the evening. Before retiring for the night another hot douche should be taken. The application should be made twice a week, and the current gradually strengthened until 100 to 150 m.a. are reached. I am convinced that there is nothing to be gained from the use of higher strengths; they exhaust the patient more, and have no countervailing advantage. Until at least eight applications have been made (that is, for about the first month) the patient must be cautioned against any undue exertion; indeed she should rest as much as possible. Scrupulous attention must be paid to the action of the bowels, as troubles of various kinds may follow constipation even of a day's duration. The management at the periods is a matter of prime importance. It is commonly found, that, at the first period after treatment has begun—after, say, four or five applications have been given—the flow begins by a slight sero-sanguinolent discharge, which may last for three days or so before the establishment of the period proper. At one time I was in the habit of ignoring this flux and making the application as usual. This, I now think, is a mistake; for I have

frequently found that it was immediately followed by a very profuse hæmorrhage, often of a most exhausting and sometimes of an alarming kind. It is better to refrain from electrical treatment under these circumstances, to order a hot douche twice a day until the full discharge commences; and then to advise the patient to lay up for three or four days. At this time—that is three or four days after the discharge has fairly set in—the applications may be resumed, and it will generally be found that the amount at once diminishes, and that in forty-eight hours it has entirely ceased.

At first the long sound should be used, exposing as much of the platinum as will lie in the canal. When ten or twelve applications have been made the short, thick sound may be used, if it can be passed, and the cavity treated in successive segments. This is, however, of less consequence in the treatment of fibroids than of endometritis, under which head its use has been described. The number of applications will vary; in most cases where the patient attends to instructions it will be found that twenty sittings will be enough. After the treatment is stopped the first period is usually somewhat profuse, but the succeeding ones approach more and more to the normal. In others ten more applications may be required, but this is exceptional. In any case it is advisable, after giving about twenty applications, to cease for a time and to watch one or two periods, and then to give a few more if this course seems to be indicated. Almost from the very first the improvement in general tone and vigour is remarkable; the patient feels stronger, eats better, and especially sleeps sounder. It is, indeed, in many cases, necessary to caution her against the too free indulgence in exercise, to which she may be tempted by her increased sense of well-being.

Next we may consider the cases in which pain is the special symptom. In a certain number of these the pain is chiefly dysmenorrhœal, and in them it is usually accompanied by a considerable amount of menorrhagia. The tumour in such cases is either situated low down near the cervix, the uterus being usually markedly flexed; or the condition is accompanied by a considerable amount of endometritis, and is characterised by the profusion of leucorrhœa between the periods.

In such cases the treatment should be conducted on much the same lines as in the group already discussed. The pain at the onset of the period will be very greatly relieved if, at the sitting just before the period is due, the short sound be so introduced that the active part lies just beyond the os internum, and a positive application be made of the maximum strength which can be borne. Many cases seem to be further benefited by the use of the induced current applied at the same spot at this sitting. Indeed I am in the habit of using both currents simultaneously during the sitting previous to the period. This can be done most conveniently by the arrangement known as the de Watteville key, which is fitted to properly arranged batteries and switch boards. The strength of both currents should be as much as the patient can bear.

In other cases the pain is a more constant element; and where it is



not due to inflammatory conditions of the annexa, it is usually caused by the tendency of the tumour to become impacted in the pelvis, either as the result of its steady growth, or from the vascular flushing which precedes the period or sometimes arises from external causes, such as constipation. In these cases examination will show that the tumour nearly fills the pelvis, or else grows from the wall of a very much retroverted uterus. In either case it resists any attempt at displacement upwards; and such attempts are always the cause of much pain. In many of the subjects of this condition rectal and vesical tenesmus give rise to added distress, the latter especially being the source of much misery. It is well known that many of these cases can be greatly relieved for long periods by a course of hot douches extending over two or more months. This no doubt acts by stimulating the muscular fibres, and so diminishing the congestion of the organ; and this sometimes even to such an extent that the tumour may be pushed clear of the pelvis, and prevented from returning to it by means of a ring or other pessary. In most cases, however, it will be found that a quicker, and in the end a much more satisfactory result may be obtained by the judicious use of electricity. It is more speedy, for after two or three applications very violent tenesmus may disappear, and it is often immensely relieved after a single application. But more than this, the influence of electricity is to check the further growth of the tumour, and in many cases it will actually produce a diminution of it; to lift it into the abdomen has no such effect, but simply gives it room to grow without the production of painful pressure symptoms. Take, then, a case in which the tumour is nearly filling the pelvis, and is causing some degree of vesical or rectal tenesmus. The long sound should be introduced into the uterus, special care being taken to avoid the production of all undue pain. If, in spite of this, great pain is complained of by the time the abdominal pad is applied, the electrodes should be connected to the induction coil, and an induced current administered, of gradually increasing strength, with the interruptions as rapid as possible, and kept up until a feeling of numbness is induced in the pelvis generally. With the large pad the current can be borne nearly as strong as the instrument can give, and generally the numb sensation comes on within ten minutes. When this is fairly established the coil may be disconnected and the continuous current applied, the sound being positive. This should be increased until 60 to 80 m.a. are reached, and the current should then be maintained for about ten minutes. The same care as to rest and the use of the hot douche must be exacted. The sense of relief which follows even one application of this nature is often very remarkable; and after five or six sittings the patient will usually express herself as being quite comfortable. It is not wise, however, to stop at this point. Fifteen to twenty applications should be given, and it will usually be found long before this that the uterus is freely movable, and that, in the case of a retroversion, a pessary can be worn with perfect comfort. Of course in many cases the passing of the sound



gives rise to no great pain, and in these the preliminary faradisation is not necessary. In none need the current ever exceed 150 m.a.; and 100 m.a. will usually be found sufficient.

It is, however, of the greatest consequence in connection with this group of cases to bear in mind that some of the symptoms may be due to the presence of conditions in the annexa—such as pyosalpingitis—which absolutely contra-indicate electrical treatment. Where there is the slightest suspicion of the presence of such elements in the case great care must be employed in beginning the treatment—a small current being used, and any febrile reaction carefully watched for. If this occur, or if the pain seem in any way aggravated by the treatment, further procedure in this direction should be abandoned.

**The Use of Electro-puncture.**—All authors seem to be agreed that whenever the current can be passed by the endometrium, it is better so to pass it. Consequently whenever the sound-electrode can be introduced into the uterus without resort to violent measures, this method of applying the internal electrode should be adopted. There is, however, a certain group of cases in which it is impossible to pass the sound. This state of things is brought about by so great a displacement of the uterus, backwards or forwards, by the tumour as to tilt the cervix and so put it out of reach; or it may arise from the downward growth of a lobule of a large tumour, or of one mass of a multiple tumour, the main body of which is in the abdomen. In these cases the roof of the vagina is generally occupied by a hard, solid mass of spherical outline, the cervix being just within or altogether beyond reach. In such cases pain is usually the chief complaint—though, of course, hæmorrhage is often present as well. The passage of the sound being out of the question, the only means of dealing with the tumour electrically is by means of electro-puncture. Now, while admitting the obviously greater risk involved in this procedure, I do not for a moment admit that the risk is in any sense sufficient to forbid it, if it be carried out with certain simple precautions. The marvellous relief which may follow the practice of puncture in cases in which hysterectomy is positively the only alternative, is, to my mind, an ample reason for its use in properly selected cases. I have used it many times, and I have had only one case in which its results gave rise to any anxiety; in that case conditions were present which can be easily excluded in any other.

The instrument employed for the puncture has been already described; it is simply an enlarged electrolysis needle (see Fig. 108); and the special condition of its introduction is that it be buried at least deeply enough to allow the sheathing to pass through the mucous membrane of the vaginal roof. In this way the formation of a sinus or sinuses in the roof is avoided. On the other hand if, as is advised by Apostoli and others, a bare steel or platinum needle or trocar be used, with the insulating sheath up to the vaginal roof, but not through it, the latter is acted upon by the current as well as the deeper parts, and an open channel is formed from the vagina to the deepest part of the puncture.

For purposes of description let us take a case where the roof of the vagina or posterior wall is blocked by a fibroid mass causing pain and pressure symptoms, and where it is impossible to pass the sound. Immediately before the operation a strong corrosive or carbolic douche, copious enough to remove any trace of discharge of any sort from the vagina, must be given. The patient should then be placed on the couch in the dorsal position. If a bed be used it must be firm, and she must lie as near the edge of it as possible; the knees must be drawn up and widely separated, and the feet firmly planted. As the patient must not be disturbed after the puncture is made, the abdominal pad should now be applied and its connecting cord, the positive one, attached. The needle, which should have been standing in a 1-20 carbolic solution, is now attached to the negative connecting cord and taken in the right hand. Its point, protected by the pulp of the forefinger, is carried along the vagina until the most prominent part of the tumour is felt. The tip of the finger is used to determine if any pulsating vessel can be felt over this part; if not, the point is presented to it and steadily held with the right hand, while the left is employed to press on the handle until the point passes  $\frac{1}{2}$  or  $\frac{3}{4}$  of an inch through the mucous membrane. The length can be previously marked by tying a piece of silk thread firmly round the insulator at the proper distance from the point. As the needle tapers to the point the thread, if properly tied, cannot slip up the stem, and an accurate guide to the depth of puncture is thus secured.

The pain caused is very slight; it is usually confined to that produced by the puncture of the vaginal roof, and is but momentary. In connection with this electro-puncture a good deal has been made of the supposed risk of injuring the bladder or other organs in introducing the needle. I have never seen a case where there was the slightest risk of such an injury. In cases suitable for puncture the pelvic roof is so completely occupied by the tumour that no other organ can encroach upon it, and it is quite safe to select the most prominent part of the tumour for the puncture. This will usually be found well behind the middle point of the pelvis, where we are a good deal nearer the rectum than the bladder. Everything now being in position, the needle is handed to the nurse, the forefinger being kept in position against the roof of the vagina to make sure that there is no displacement as she takes charge of it. The current is now carefully turned on, the same precautions being observed as were previously described. A strength of 100 m.a. is usually borne with ease, and this may be continued for from five to eight minutes. As a matter of fact these negative electro-punctures are rather more easily borne than intra-uterine applications; and, after two or three sittings, one may safely use currents of 150 to 200 m.a. When the current is taken off the needle is withdrawn, the pad removed, and absolute quiet enjoined for half an hour. The patient may then dress and go home, but should go to bed at once. A douche must be given at night, and repeated regularly once a day at least. There is often a little red discharge for a day or two after the operation, but I have never seen any serious hæmorrhage

follow it. It is wise to allow a week between each sitting. The same precautions and procedure must be rigorously observed at the subsequent sittings, and it is well to avoid puncturing again in the same spot until several weeks have intervened. For ten days or more the site of the puncture can be recognised by the presence of a little dimple or pucker: after that time it should leave no trace.

Apostoli and most other authors enjoin the use of the negative pole for electro-puncture. This has two advantages: 1st, it permits the use of a steel needle for an electrode; and, 2nd, the needle is easily withdrawn at the end of the operation on account of the looseness of the disintegrated tissue. It is also supposed to have the advantage of breaking up more tissue than the positive. This difference is, however, rather apparent than real, as we have already seen. It has the disadvantage that it might favour hæmorrhage through the puncture, if by any chance there were a tendency to this accident; and it has the distinct and much more serious disadvantage of tending to cause a congestion of the tissues in the region of the puncture. In this case we should hardly expect the same immediate shrinkage which we certainly get in intra-uterine positive applications, and we should miss to some extent the immediate and gratifying relief of pressure symptoms which usually follows a positive application. There is then, it seems to me, no objection whatever to the employment of the positive electro-puncture if the negative fail to give the desired relief. A platinum needle must be used, and if, as sometimes happens even with platinum, the needle does not come away of itself after stopping the current, a negative current of not more than 2 or 3 m.a. for a few seconds will free it. We thus get the soothing and congestion-reducing effects of the anode, with probably no diminution of the electrolytic influence of the kathode.

In concluding our consideration of the treatment of fibroid tumours of the uterus by "Apostoli's method" it will be well to summarise the claims made for it: 1. In submucous and interstitial fibroids it controls hæmorrhage, abolishes metrorrhagia, and restores the period to normal limits: 2. It relieves pain, both menstrual and intermenstrual: 3. It produces an immediate diminution in the congestion, and hence in the bulk, of an impacted tumour; and, though this may be evanescent, it gives great relief to pressure symptoms, and may enable such a tumour to be freed: 4. The growth of submucous and interstitial tumours is almost always completely arrested: 5. In a certain number of cases the tumour is distinctly reduced in size: 6. In a very small number the tumour may wholly or nearly disappear: 7. The effect of the treatment is a symptomatic, not a radical cure.

*Pelvic Exudations.* — The frequency with which perimetrie and parametric exudations occur in the female pelvis, the disorganisation of function they cause, and the pain and distress they bring with them, are well known to every gynæcologist. Nor is he less well aware of the persistence of these deposits, and of their power of resistance to almost every form of treatment to which they can be subjected.



These exudations may take the form of a bulging mass, in one or other or both sides of the uterus, of a dense, firm, and unyielding quality, fixing the uterus and displacing it to one or other side. This form is usually the result of a cellulitis beginning in the cellular tissue of the roof of the vagina on one side, sometimes being confined to that side, but often finding its way to the other. Again, one may find a dense mass behind the uterus, occupying the pouch of Douglas; not bulging to any extent into the vagina, but binding the uterus to the posterior or lateral aspects of the pelvis. This is most frequently the result of a peritonitis, and, like the cellulitis, is generally septic in its origin. In other cases the whole pelvic viscera may be matted together, the pelvis being roofed in, as it were, by the inflammatory exudation, partly perimetric, partly cellutic. The tendency of these deposits in the early stage of their history to suppuration is well known; but in many cases this does not occur, and the mass remains unchanged for months and years, a constant cause of pain and distress, of dysmenorrhœa and menorrhagia, reducing the subject to a state of profound debility and misery. The treatment of these deposits is often one of the most tedious and disheartening experiences of gynæcological practice. Some of them, no doubt, become absorbed, either spontaneously or as the result of treatment; but in other cases, the treatment by blisters, iodine, ichthyol, hot water, glycerine, and other remedies, proves futile, and the condition remains unaltered for an indefinite time.

It is in the treatment of some of these obstinate and previously hopeless conditions that electricity has achieved some of its most brilliant triumphs. However great may be the difference of opinion as to its efficiency in the treatment of fibroid tumours, few physicians who have given its virtues a fair trial in the present class of cases, or have watched the course of a case under treatment, are not compelled to admit that its beneficial results are most striking. I have seen an enormous exudative mass, which was proved by an exploratory incision to have roofed in the pelvis and filled every fold of the peritoneum with a solid deposit, disappear after twenty-five applications of electricity; indeed it required a careful examination by an expert to say that there was anything abnormal in the pelvis. And the patient, who had spent years in bed as a helpless invalid, at the end of a few months' treatment was able to take a five miles' walk without discomfort or undue fatigue.

The value of this treatment in these cases cannot well be overrated. Apostoli, Goelet of New York, and others, are strongly in favour of beginning the treatment of cases of this kind during the acute stage, when fever, pain, and the actual process of exudation are going on. They advise the use of intra-vaginal faradisation with the fine wire coil, asserting that this relieves the pain, calms the patient, and diminishes the amount of exudation. They recommend that a bulbous metallic electrode be placed in the affected fornix, and gentle faradisation carried on until the pain is relieved, a process which occupies fifteen or twenty minutes, and that this process should be repeated once or twice daily.



In the subacute stage the continuous current may be substituted, a cotton or clay covered vaginal electrode being used, and a pad on the abdomen. The current strength may vary from 20 to 30 m.a., the anode being used internally. This again is said to diminish the pain and to reduce the exudation. These applications may be made every second day. The only contra-indication to this line of treatment, according to these authors, is an intolerance of the application on account of increase of pain and rise of temperature. These events are probably indications of a change in the direction of suppuration which is generally regarded as being an absolute contra-indication.

I have had no experience of this treatment at these stages of the disorder, and cannot therefore speak of it with any authority. But in the chronic condition, when all active change has ceased, and when the mass has assumed its firm, dense, immovable character, I can speak of the value of electrical treatment with every confidence. When the mass has the general character of a cellulitis — when, that is to say, it is lateral to the uterus and bulges into the lateral fornix — I believe the best results are to be obtained from electro-puncture; and, following the general practice, I have always employed the kathode in these cases, though here again I should suggest that this rule need not be binding. The plan of procedure is precisely the same as in the puncture of a fibroid; only, I should advise that the first few punctures be done at the patient's house so as to give her the benefit of complete rest after the sitting. The current strength should not exceed 50 m.a. on the first three or four occasions, but it may then be gradually increased until 100 or 150 m.a. are attained, provided no unfavourable reaction follow. After a variable number of applications, say three to six, it will be found that the bulging is steadily diminishing, and that it becomes more and more difficult to define a suitable spot for insertion of the needle. When this occurs the subsequent resolution is generally rapid. It seems undoubtedly to be favoured, however, by a systematic pursuit of the treatment by intra-uterine application, and this should now be substituted for the punctures. In a comparatively short space of time, varying from two to four months, according to the extent of the deposit, the treatment may be completed. This will be determined by the almost complete disappearance of the mass, by the mobility of the uterus and ovaries, and by the nearly entire cessation of pain and pelvic distress.

In retro-uterine perimetric exudations, where a defined mass can be felt, a similar procedure may be resorted to. On account of the greater difficulty of securing this definition, the puncture should be made with great caution, and should never exceed half an inch in depth. The change in the mass of adhesions which follows necessitates an earlier resort to intra-uterine applications than in the case of parametric deposits. On account of the pain which the negative pole always sets up, these, at any rate, at first should be anodal. In my experience, perimetric exudations are dispersed more slowly than parametric ones; one explanation probably being that the former can tolerate smaller

current strengths than the latter. But the ultimate result in the majority of both cases is the same; namely, an almost complete dispersion of the deposit, restored mobility of the pelvic organs, and an enormous relief from pain.

R. MILNE MURRAY.

#### REFERENCES

A complete bibliography of gynecological electrotherapeutics will be found in *Le Courant continu en Gynécologie*, by Dr. Albert Weil, Paris, 1895, embracing almost every paper bearing on the subject from 1857 to 1895.

The following are some of the more important contributions with reference to Apostoli's method:—

1. APOSTOLI. "Nouveau traitement des fibromes de l'utérus; lecture faite de 29 juillet à l'Académie des sciences," *Comptes rendus*, 1884.—2. *Ibid.* "Sur nouveau traitement électrique des périmétrites," *Comptes rendus Congrès de Copenhague*, ii. 141.—3. *Ibid.* "Documents pour servir à l'histoire de l'électrothérapie des fibromes utérins," *Revue intern. d'électricité*, 1891.—4. CARLET. *Traitement électrique des tumeurs fibreuses de l'utérus*. Thèse de Paris, 1884.—5. *Ibid.* "Traitement électrique des tumeurs fibreuses de l'utérus d'après la méthode du Dr. Apostoli," *Ann. Soc. de med. de Gand.*, 1885.—6. ENGELMANN, F. "Die Elektrizität in der Gynäkologie," *Arch. f. Gynäk.* xxxvi. p. 193.—7. GOELET. *The Electrotherapeutics of Gynæcology*. Detroit, 1892.—8. *International System of Electrotherapeutics*. Philadelphia, 1894. See various articles by Grand and Famarque, Goelet, Kellogg, etc.—9. KEITH, THOMAS. "Dr. Apostoli's Treatment of Uterine Fibroids," *Brit. Med. Journ.* 14th July 1888.—10. KEITH, THOMAS and SKENE. *The Treatment of Uterine Tumours by Electricity*. Edinburgh, 1889.—11. KELLOGG. "Summary of my Personal Experience with Electrolysis in the Treatment of Fibroid Tumours," *Journ. Amer. Med. Assoc.* vol. xviii. 1892.—12. MARTIN, FRANKLIN H. "Electrolysis in Gynæcology," *Journal Amer. Med. Ass.* Chicago, 1886, p. 61.—13. *Ibid.* *Electricity in Diseases of Women and Obstetrics*. Chicago, 1893.—14. MASSEY, BETTON. *Electricity in Diseases of Women*. Philadelphia, 1889.—15. MUNDÉ. "My Recent Experience with Electricity in Gynæcology," *Am. Journ. Obstet.* June 1890.—16. MURRAY, MILNE. "The Treatment of Pelvic Disease by Electricity," *Trans. Edin. Obstet. Soc.* 1890.—17. NÄGEL. "Ueber die elektrische Behandlung der Frauenkrankheiten, besonders der Myome," *Zeit. f. Geburts. u. Gyne.* Bd. xxii. Heft 3, 1893.—18. PLAYFAIR. *Electricity in the Treatment of Uterine Disease*, 11th June 1887 and 14th January 1888.—19. REGNIER. *Traitement des maladies des Femmes par l'électricité*. Paris, 1896.—20. WEBB. "On the Treatment of Fibroid Tumours of the Uterus by Electricity," *Brit. Med. Jour.* May to July 1887.—21. WEIL. *Le Courant continu en Gynécologie*. Paris, 1895.

R. M. M.

## DISORDERS OF MENSTRUATION

THE line of demarcation between menstruation which conforms to the normal order, and menstruation which presents features sufficiently abnormal to permit of its being considered disordered, is very difficult to draw. Menstruation which would be normal in one woman, might in another be regarded as painful, or profuse, or scanty; even in the same subject, many deviations from the rule are perfectly consistent with health, and are not necessarily due to any local disease. In this article the various deviations from normal menstruation will be discussed; they are but symptoms, and when due to gross pathological lesions the description of these must be sought elsewhere. The prominent disorders are amenorrhœa, menorrhagia, and dysmenorrhœa, but before reaching a consideration of these, it will be well to discuss the questions of premature and protracted menstruation.

**Premature Menstruation.**—Menstruation usually begins in the fifteenth year, and ends between forty-five and fifty; thus menstrual life normally lasts from thirty to thirty-five years. But menstruation occasionally sets in at a much earlier age. One case was recorded by Campbell, in which a girl had menstruated regularly every three weeks since birth. In many of these cases of precocious menstruation the general and sexual development is premature; the pubis becomes covered with hair, the mammæ enlarge, and both the external and internal generative organs undergo rapid development.

I have tabulated the cases found recorded under the following heads; and, where the case seemed one of more outstanding peculiarity, I have shortly epitomised its history:—

1. Precocious menstruation with an early appearance of the external manifestations of puberty.
2. Precocious sexual development without menstruation.
3. Menstruation previous to development of the sexual organs.
4. Early conception and pregnancy.
5. Premature sexual development associated with tumours of the generative organs.

1. One of the most striking cases illustrative of the first group is the oft quoted one of De Beau, to the record of which he considered it advisable to append the signatures of four physicians, a mayor, and a British consul.

The history is as follows:—“Matilda H. was born on the 31st December 1829. She came into the world with her mammæ perfectly formed, and the mons veneris covered with hairs, as much as a girl between thirteen and fourteen years old. When precisely three years old the catamenia made their appearance, and have continued to appear regularly every month until the present time (1832), and as copious as any woman might have them, each period taking four days. . . . Her

mammæ are now of the size of a full-grown orange; and the dimensions of the pelvis are, in my opinion, such as to enable her to bear children when eight years old, and very likely sooner."

In Campbell's case (2) the catamenia set in a few days after birth, and occurred regularly at periods of three weeks and two or three days. This order continued until the patient died at the age of four years. Her appearance was that of a girl of ten or eleven, the mammæ and external genitals having the appearances proper to puberty. The development of the pelvis and of all the deep-seated genitals was found at the autopsy to be very considerable.

R. B. Smart gives a table of eight recorded cases, and describes in full detail a case which came under his own observation, with two accompanying photographs of the patient. The catamenia in this girl appeared at three years and six months, and the hair on the pubis shortly antecedent to that.

Bouchart narrates the history of a girl, N. O., and the appearance she presented at the age of four years. She had been born with the breasts notably enlarged, she began to menstruate at the age of twenty-two months, and at the time of examination she presented the appearance of puberty as regards her breasts and genitals. Menstruation in her case was very regular in its recurrence, it lasted four to six days, and was in quantity equal to that of an adult.

Harris classifies precocious menstruation in two varieties: 1st, that occurring during infancy; 2nd, that occurring between the ages of seven and thirteen years. He records the case of a girl who came under his own observation, in whom menstruation appeared at the age of nine and a half years, and in whom the other evidences of puberty manifested themselves.

C. E. Harle records the result of a post-mortem examination on a child who had begun to menstruate at the age of five months; the menstruation returned regularly till the fourteenth month, when the child died of diarrhœa. The pudendum was large and clothed with hair; the uterus was large, the os patent and the lips congested, the vessels of the broad ligament were injected, and both ovaries were cystic.

The other cases I have noted under this category are the following:—



Author.	Menstruation began at Age of	External Appearances of Puberty.
Astley Cooper in <i>Med. and Chir. Trans.</i> 1813.	3 years.	In breasts, axillæ and on pubes.
Thomas Embling in <i>Lancet</i> , 1848. Aveling in <i>Lancet</i> , 1866, gives a reference list of sixteen cases by different observers.	2 years.	Mammæ and pubes.
Prochownik in <i>Arch. für Gynaek.</i> 1881.	1 year.	In breasts, axillæ and on pubes. Internal organs not enlarged.
Berry in <i>Medical Press</i> for 1882.	5 years and 4 months.	Breasts and genitals.
A. van Denver in <i>Am. Journal of Obstet.</i> 1883.	4 months.	Mammæ greatly enlarged.
Four of the following cases are cited by Pozzi in his <i>Gynécologie</i> :—		
Cabade in <i>Gaz. méd. de Paris</i> , 1883.	8 months.	Rapid development.
Wallent in <i>Dissert. Inaug.</i> Breslau, 1886.	1 year 3 months.	
Casati in <i>Il. Raccogliatore</i> , 1886.	6 years.	Rectal examination, "uterus pubère."
Diamant in <i>Intern. klin. Rundschau</i> , 1888.	6 years.	Extl. genitals.
Jagoe in <i>New York Med. Journ.</i> 1889.	2 years.	Extl. genitals.

2. The indication of a sexual precocity, manifested by the outward signs on the breasts and pudenda, but unaccompanied by a menstrual discharge, is unusual. Few instances of this character have been noted, but that described by William Cook is distinctive enough.

3. Menstruation occurring without any change in the genitals is not so unusual as the preceding, but it is rare for a child to have the catamenia established for a period of years without other associated phenomena presenting themselves.

Pozzi cited Bernard's case of a girl who menstruated regularly from birth up to the age of twelve years without any development of her genital organs.

In the same class may be included the cases noted by the following authors :—

Allbutt reports a case where the menstrual discharge occurred periodically until the youthful patient died of exhaustion.

Clarence Harding reports that in a family of two daughters both suffered for a time from a periodic discharge, hæmorrhagic in character, in the elder of whom the discharge vanished until puberty was established, when it recurred.

4. Many remarkable instances of early pregnancy have been put on record by trustworthy authorities; the majority of those in this country have occurred after the age of twelve. There is, however, in continental literature no great scarcity of reports of pregnancies at a much earlier age.

The following table of cases which I have collected from various sources has been arranged in order of age. The majority of the records bear evidence of being trustworthy : —

Author.	Reference.	Develop-ment.	Menstrua-tion.	Impregna-tion.	Delivery.	State of Child.
Müller . .	<i>Cyclop. of Obst. and Gyneec.</i>	Excessively at birth.	2nd year.	8 years.	Instrumental, 8-9 months.	Dead.
Schmidt . .	<i>Essais Historiques, 1779.</i>	Sexual organs developed.	2nd year.	..	8 years 10 months.	Full term, dead.
Bodd . . .	..	..	1 year irregular, 7 years regular.	..	8 years 10½ months.	..
Molitor . .	..	Hair on pubis at birth.	4th year.	8 years and 3 months.	Premature, 5th month.	Fœtus—a 3 months'.
Dodd . . .	<i>Lancet, 1881.</i>	Pubes and axilla covered with hair.	12 months.	8 years and 10 months.	..	Weighed 7 lbs.
Rowlett . .	<i>Trans. Med. Jour. 1846.</i>	A few weeks after birth.	12 months.	9 years and 3 months.	10 years.	7½ lbs.
Bayllis . .	<i>Brit. Med. and Surg. Jour. 1846.</i>	..	9 years and 10 months.	..	10 years and 8 months.	Alive, weighed 8 lbs.
Robertson .	<i>Midwifery.</i>	..	..	12th year.	12 years and a few months.	..
Smith . . .	<i>Lond. Med. Gazette, 1845.</i>	No history.	10 years.	11 years.	12½ years.	Fully developed.
May . . . .	<i>Lancet, 1880.</i>	..	Once before conception.	..	13 years.	Well developed.
Heywood .	<i>Brit. Med. Jour. 1881.</i>	..	12 years and 6 months.	12 years and 8 months.	13 years and 4 months.	..
Wilson . .	<i>Edin. Med. Jour. 1861.</i>	No precocity.	..	12 years and 9 months.	13 years and 6 months.	Full grown.
Chapman .	<i>Assoc. Med. Jour. 1856.</i>	..	..	13 years and 1 month.	13 years and 10 months.	Full grown.

5. It has been asserted that among the causes tending to produce changes in the sexual apparatus peculiar to puberty we should include neoplasms affecting or related to the internal generative organs. This would appear, however, to be far from the usual rule, and to be rather the exception. In order to ascertain the frequency of this occurrence, I have examined the records of twenty-six laparotomies performed on children under puberty; and in one case only did there seem to have been signs so marked as to arrest the attention of the operator so strongly as to induce him to give a description of the child's appearance. On this one occasion the narrator and operator was Mr. R. Clement Lucas.

The child was aged seven, and had had a hæmorrhagic discharge from the vagina, which occurred whilst she remained in hospital. The mammæ were firm, and about the size of oranges; the mons veneris was of unusual elevation, and covered with hair about one inch in length. There was a tumour of the right ovary, which was removed, and the child made a good recovery. The vaginal discharge disappeared, and the mammary prominence subsided before she left the hospital.

Premature menstruation is in a large measure hereditary; but a more important factor seems to be immoral associations. Neglected children by coming in contact with vicious girls older than themselves frequently have their attention prematurely directed to the sexual organs. Bad habits, too, the result of irritation produced by ascarides in the rectum, want of cleanliness, or caseous secretions about the clitoris, may lead to a precocious development. Over-excitability of the brain has also been considered by some authors as a factor in the production of a too early puberty.

The management of such cases consists in removing the cause as far as possible. Masturbation should be prevented by careful supervision of the child and by the relief of local irritations. General rest and tonic treatment with removal from nervous excitement should be advised.

**Protracted Menstruation.** — A history of this condition is to be received with caution. Women past the menopause are apt to consider any intermittent or irregular discharge as a continuation of the menses. Such a hæmorrhagic discharge is, however, in most cases due to the existence of some distinct pathological lesion; such as senile uterine catarrh, polypus, fibroma, and especially cancer: it is sometimes associated with a gouty diathesis. Nevertheless, some authentic cases have been recorded in which normal menstruation continued even till the fifty-seventh year. But it may be taken as an ascertained fact that, so far as normal menstruation with accompanying ovulation is concerned, authentic cases of pregnancy are not recorded after the age of fifty-two, or of fifty-four at the outside. It is safe, therefore, to presume that these ages indicate the extreme limit of normal menstruation accompanied by fertility.

AMENORRHŒA, or absence of the menstrual discharge, is primary when the patient has never menstruated at all; secondary when menstruation has previously taken place. It exists as the normal condition during pregnancy and lactation.

**Primary Amenorrhœa.** — (a) *Primary permanent amenorrhœa.* — The most marked cases are those in which the ovaries, or uterus, or both, continue in a rudimentary condition, or are altogether absent, while the external genitals are normally formed. The girl's sexual development ceases, and her characteristics, physically and mentally, tend to the masculine, or at least to a mixed type. The cause is absolutely unknown. Heredity, or interruption of normal embryonic development, or interference with it, cannot be accepted as satisfactory explanations. Nothing can be done to relieve the condition.

Cases of this kind may be grouped in two classes: one is characterised by complete absence of sexual development. The mammæ are undeveloped, the pubes bare (which is specially characteristic), and the uterus and ovaries are found on vaginal examination to be rudimentary, if not altogether absent. The second class consists of cases of women

usually of "masculine" habits—acrobats, for example; in them the mammæ are well developed, the upper lip is hirsute, there is a copious development of hair over the pubes, and on vaginal examination the uterus and ovaries are found, if not normal in size, very nearly approximating to the normal. Such cases seem to be accounted for by the fact that the muscular development of the woman has been pressed from early girlhood to such an extent as to interfere with the usual function of the reproductive organs.

(b) *Primary temporary amenorrhœa* may be due to chlorosis occurring in girls under the age of puberty. In this condition the vascular system is at fault; not only are the walls of the vessels themselves imperfect, but the blood contains rather fewer red corpuscles than is normal, and they are especially deficient in hæmoglobin. In such cases, however, there is a tendency to plumpness from undue development of adipose and cellular tissue. The general appearances and symptoms of such patients are well known. Menstruation occurs later than normal, and when it does set in the flow is scanty and of short duration; the intermenstrual periods also are longer.

The treatment is the ordinary treatment of chlorosis: it consists in the administration of arsenic and iron; rest at first and exercise later; careful non-fattening diet and saline purgatives. In many cases the digestion is also at fault, and has to be rectified by the usual stomachic remedies. If circumstances permit, much advantage may be derived from a course of the waters at such places as Tarasp and Schwalbach.

(c) *Delayed puberty*.—Here the general and sexual development are complete, and yet the girl fails to menstruate. These cases are sometimes accounted for by the fact that the "nutritive forces have been directed towards the general organisation." Some such girls have often too much physical labour. Thus among the poor, who do a great deal of manual outdoor work at an early age, menstruation is often delayed. On the other hand, brain workers often exhibit the same symptom; by overwork of the higher functions the nutritive and reproductive systems are thrown out of balance.

The management of such cases is easy and attended as a rule by satisfactory results. Change of occupation, rest for the body if the physical strength has been overtaxed, and rest for the mind when its faculties have been strained, will generally effect a cure.

**Secondary Amenorrhœa.**—This may be the result of various pathological conditions. Thus it may be due to such constitutional derangement as results from anæmia, chlorosis, diabetes, Bright's disease, malaria, cancerous cachexia, tuberculosis, acute illnesses, and fever. In the same way acute or chronic surgical affections may be potent in producing amenorrhœa. Some authors lay much stress upon the amenorrhœa which is the occasional result of syphilis. This symptom, however, is no doubt due simply to the anæmic condition which is associated with the disease.



The suppression of the menses that occurs in young obese women is to be accounted for in the same way.

The influence of the nervous system is distinctly a factor in the production of amenorrhœa. Thus a sudden fright has not infrequently been known to cause a temporary suppression of the menstrual flow — as when an unmarried woman supposes herself to be pregnant; on the other hand, it must not be forgotten that in a few cases a stimulating rather than an inhibitory action has been known to follow a sudden emotion, and menstruation has set in. Again, amenorrhœa due to the influence of the nervous system is shown in the insane, and in prisoners, a change which is due no doubt to the mental depression consequent upon seclusion. Chills are very commonly responsible for the cessation of the menstrual flow, and in such cases the influence may be conducted through the vasomotor tract.

The amenorrhœa of pseudo-pregnancy occurring in the newly married, in those who have been leading irregular lives, and in those who are reaching the menopause, is well known, and is to be accounted for by an influence acting through the nervous system. Pozzi defines it by attributing it to “auto-suggestion.”

Amenorrhœa often occurs in young girls who are sent to Germany or France to school; when the change of climate and diet appears to lead to this symptom. Similarly, a long sea-voyage may produce such a condition.

The local diseases which cause suppression are many. Atrophy of the uterus commonly leads to it, and this may be the result of superinvolution from repeated pregnancies, prolonged lactation, or tuberculosis. So, too, many cases are recorded in which an early menopause has occurred without apparent reason: menstruation gradually or suddenly ceases, and on examination the internal generative organs are found in the atrophic state of a normal climacteric.

Tumour of the ovary may not interfere with menstruation in any way; but occasionally, when both ovaries are completely destroyed by cystic or other degeneration, menstruation ceases. If but one ovary be affected menstruation may go on fairly regularly, as it may when the ovaries are the seat of inflammatory changes. In the early stage of inflammation the tendency is rather to menorrhagia; but in the later sclerotic stage amenorrhœa does occasionally though rarely occur.

Amenorrhœa due to atresia of the cervix or vagina or hymen is a condition which demands special attention. This is not the place in which to discuss the deformities producing hæmatometra and hæmatokolpos, in each of which menstruation is prevented by the occlusion of the genital canal. In most cases the condition can be distinguished perfectly well from amenorrhœa due to non-development or to constitutional causes; whereas in the latter there are none of the local or constitutional disturbances which accompany menstruation, in the former pain and discomfort are manifested with regularity every month, and a well-marked bulging may be discovered at the vulva; or a tumour may present itself

suprapubically. This tumour may sometimes be so high as to be mistaken for one of the abdominal organs; this was notably the case in a young girl under my own care, where a round tumour presented itself well up in the ilio-lumbar region which was mistaken for an enlarged kidney. The misleading point was that the girl had constant pain in this region. As, though eighteen years old, she had never menstruated, an examination was made of her vulva, and the tense, bulging, imperforate hymen was discovered. This was treated in the usual way with a thermo-cautery; slow removal of the contained fluid was accomplished with complete antiseptic precautions, the whole ilio-lumbar swelling disappeared, and regular menstruation was established.

*Removal of the Ovaries.*—Whether removal of both ovaries causes cessation of menstruation or not, there are two classes of cases to be considered: firstly, those in which an excised ovary was the seat of tumours, cystic, papillary, or solid; and, secondly, those in which the ovaries on removal were either healthy, or were removed on account of some inflammatory or slightly cystic condition, or on account of dysmenorrhœa. As regards the first class, it is often difficult to state for certain that the whole of the ovary has been removed; a small portion may be left in the pedicle, and this may be quite sufficient to account for the continuance of menstruation. As regards the second class, it has been affirmed by Lusk that in the great majority of cases (86 per cent) menstruation ceases, if not at once, at least within a year of the removal of the ovaries. In these cases some authors have supposed the existence of a supplementary ovary; but surely the “law of persistence of habit” is sufficient to account for the phenomenon. It is an automatic ebb and flow produced through the influence of the nervous system.

Another factor in the production of this continuation of menstruation after oophorectomy is the condition of the uterine mucosa. This is frequently in a congested, if not in an inflammatory condition, and for this reason some operators advise that, in all cases, curettage of the uterus should be performed after the removal of the appendages. Czempin considers it possible that the cicatrisation following the operation may compress the veins, and so keep up a passive congestion and a continuance of the monthly flow. Oophorectomy not only leads to local disturbances,—chiefly to amenorrhœa,—but it is apt to lead to general physical changes. There is an increase of plumpness of the person, although the mammae generally atrophy; and there is frequently a change of disposition, which often becomes more placid.

If the Fallopian tubes alone are removed, the ovaries being healthy, these local and general changes do not occur.

My own experience in cases of removal of the ovaries for inflammatory conditions, tubal enlargements, and minor ovarian disorders, does not coincide with that of Lusk; I have found that a much larger proportion of women continue to menstruate regularly for years after the ovaries have been removed, and that the only difference in these patients is that the

menopause is antedated by some years, and that, in most of them, though by no means in all, menstruation, if it continue, is without pain.

In a few cases of this kind, especially those in which the operation was undertaken for the cure of fibroids, I have found that the hæmorrhage has sometimes been increased.

Though it is obviously impossible to follow every case to a definite issue, the following is my experience in the matter:—

#### Removal of the Ovaries and Tubes for Minor Affections.

100 Cases.	In 40	menstruation	ceased.
	In 30	„	continued irregularly for years.
	In 20	„	„ regularly.
	In 10	„	recurred at long intervals.

*Symptoms of Amenorrhœa.*— Besides the absence of the periodic flow, which is, of course, the chief symptom, numerous constitutional symptoms are observed as the accompaniments of amenorrhœa. Thus hysteria is frequently an important and serious complication; while minor sensory disturbances, such as amblyopia and tinnitus, may be reflex or the result of anæmia. Paresis has also been known to occur, due no doubt to the accompanying hysterical condition.

There is no question that many forms of skin eruption, such as acne, pemphigus, erysipelas, herpes, eczema, and urticaria, may accompany the suppression of menstruation. Hyperidrosis, too, has been known to follow a sudden cessation of the monthly flow.

*Vicarious Menstruation.*— Many cases are recorded in which the function of menstruation has been taken up by other organs of the body, the condition being known as vicarious menstruation. Jones reports a most remarkable case in which, when menstruation was suddenly suppressed by a chill, the woman for five months thereafter had amenorrhœa, but regularly in each of these months she had for thirty six hours an abundant flow of milk from the breasts. In another case the catamenia were replaced by a profuse diarrhœa which lasted for three days every month; and in yet another a periodic leucorrhœa was the only indication of the menstrual function.

Besides these extraordinary cases, many are recorded of hæmorrhages from the respiratory or alimentary tracts, of epistaxis, hæmoptysis, or hæmatemesis replacing the normal uterine discharge. More rarely bleeding from the ear has occurred, and in one or two cases subcutaneous hæmorrhages have been observed, or a bleeding from a raw surface, such as an ulcer, has taken place regularly every month.

Perhaps a cerebral apoplexy, which occasionally has been known to follow the sudden cessation of menstruation at the menopause, or the cure of a long-continued hæmorrhoidal discharge is to be regarded as an event of a like kind.

*Treatment of Amenorrhœa.*— This naturally varies very much according to the cause. In many cases it is quite useless to administer drugs

that are supposed to act directly upon the function of menstruation, without first carefully considering whether some general constitutional condition may not account for the suppression. No doubt, in some cases, such drugs as rue, savin, or saffron, have succeeded in restoring the function; but this result has occurred in cases in which the amenorrhœa was simply due to a chill or violent emotion. When it is the result of anæmia, chlorosis, syphilis, or tuberculosis, these diseases rather call for treatment, and the pelvic organs require no special attention. In amenorrhœa from chlorosis — so common in young girls — treatment by iron and arsenic, baths and saline purgatives, is followed by excellent results; but perhaps the most useful way of combating these cases is by the persistent use of arsenic, followed by a short course of aloes and iron in pills. Many other remedies are attended with equally good results. Manganese is considered by some physicians to be as useful as iron in the treatment of anæmia; it is also supposed to have a special emmenagogue action: I have not found it nearly so satisfactory as some forms of iron. Judicious physical exercise and change of air are also important in the treatment of amenorrhœa.

As regards local treatment, this in many cases is of no avail. When the organs have become atrophied from any cause no local treatment seems to have much effect in ameliorating the condition. Electricity has been advocated by many physicians, and in the hands of some I have no doubt it has been occasionally successful; but my own experience of it has not been very encouraging.

In those instances in which the suppression of menses is due to the patient's rapidly growing obesity the indication is clear; and careful dieting, with baths and exercise, will generally effect a cure. Stimulation of the uterine mucosa by gentle curettage may sometimes be useful in securing a return of the menstrual flow.

In the amenorrhœa which results from a premature menopause due to the removal of the ovaries, the ordinary symptoms of the climacteric period — lumbar pains, flushings, giddiness, and irritability — usually appear. In such cases, besides the general treatment by bromides and tonics, the patient occasionally derives benefit from scarification of the cervix every month so as to obtain a slight local bleeding and relief of congestion.

The intra-uterine zinc and copper stem pessaries, so much advocated long ago by Sir James Simpson, are, I think, devoid of any important galvanic action, yet they evidently do good in some cases, as does scarification of the cervix, by permitting a temporary flow and giving a temporary relief.

**Scanty Menstruation.** — This condition is due to causes very similar to those of amenorrhœa. It may be either primary or acquired. If primary it remains constitutional through life; if acquired it is as the result of some intercurrent pathological condition, such as those referred to in the description of amenorrhœa proper.

Here, however, it must not be forgotten that scanty menstruation, like menorrhagia, is merely a relative term; menstruation is abnormal



when it extends beyond six days in the one direction, or is reduced to two in the other. It must also be borne in mind that, before any opinion can be given, the menstrual habit of the individual must be accurately determined.

The treatment is to be on lines similar to those laid down under the head of amenorrhœa.

In a certain class of cases inflammation which, in the first stage, tends to cause menorrhagia, at a later stage induces amenorrhœa. Such cases are best illustrated by endometritis. As is well known, the symptom of acute and subacute endometritis is menorrhagia; but when the condition has become extremely chronic, when the mucous membrane has become thin, the vessels shrunk, and the fibrous tissue greatly increased, scanty menstruation is a well-marked symptom. This condition has also been frequently observed in what is known as parametritis atrophicans, in which, owing to the contraction of an inflammatory deposit in the broad ligament, the arterial supply to the uterus has been so curtailed that scanty menstruation or even amenorrhœa has been the natural result.

**Menorrhagia and Metrorrhagia.** — By the term menorrhagia is meant an excess of discharge occurring at the time of the usual menstrual period; by metrorrhagia, hæmorrhage from the uterus not coincident with a menstrual epoch. In considering these two symptoms it is necessary, in the first place, to deal with the difficulty of deciding what amount of hæmorrhage at the monthly period is to be considered as excessive; and in the second place, as all bleeding from the vulva, apart from the menstrual flow, might at first be considered as metrorrhagia, the causes of bleedings which might wrongly be confused with metrorrhagia must be enumerated, in order that we may eliminate them, and find ourselves free to deal with the subject systematically.

Menorrhagia may occur as an excessive flow of blood during the normal number of days which constitute a period, or as an ordinary flow extending over an excessive number of days. Our only means of comparison is to ascertain if the function differs from the patient's usual habit, and, moreover, if it is affecting her general health.

In the case of delicate anæmic girls, ill enough able to sustain the nutrition of their own bodies, even an entire absence of menstrual discharge is not necessarily to be looked upon as an evil; we may find that on the restoration of health by tonic and restorative treatment the periodic discharge of blood will take place without reducing the bodily powers: on the other hand, there are women who normally menstruate for eight or ten days at each period without suffering any inconvenience or derangement of the general health. Thus, in a woman who has menstruated before, it is only by a consideration of her menstrual habit, and by making due allowance for climatic and other influences, that we can determine the standard by which her menstruation is to be judged.

At the same time it is well, for general purposes, to have an arbitrary

limit; and this we can roughly assign by observing the average time occupied by the period in a considerable number of women — a matter already discussed under amenorrhœa: we should thus be led to consider the function to be excessive if it lasted longer than six days; and the actual amount of blood lost may be estimated in terms of the diapers employed — ten to fifteen being looked upon as a fair average number for each period.

The term metrorrhagia is held to imply only bleedings from the uterus and cervix uteri: on the one hand, it is obviously impossible in a gynæcological treatise to consider at length hæmorrhages occurring in connection with pregnancy; and, on the other hand, the discussion of bleedings from the vagina and vulva belong to other chapters. It is only necessary in this place, in order to facilitate reference, that these various sources of hæmorrhage should be mentioned.

Bleeding associated with abortion, myxomatous degeneration of the chorion, placenta prævia, separation of the placenta ("Accidental Hæmorrhage"), retained placenta or membranes, inertia of the uterus, and inversion of the uterus, is fully described in works on Obstetrics.

Of sources of hæmorrhage which may be mistaken for menorrhagia we may simply mention vaginitis, with ulcerations or other lesions of the vagina; injuries of the hymen and vulva; and the rare occurrence of rupture of varicose veins in the pudenda, associated especially with pregnancy.

We have next to consider a class of causes which are independent of the special function of the uterus, but may produce bleeding from it as from any other mucous membrane of the body. These causes depend for the most part on alteration in the condition of the blood. For example, a woman of the hæmorrhagic diathesis will bleed much more profusely at her menstrual epoch than other women, as would be the case with her in epistaxis, or on the breach of any other surface. Besides hæmophilia, scorbutus and purpura act in this way; and although chlorosis, as we have found above, tends rather to produce a condition of amenorrhœa with leucorrhœa, yet in some cases it leads to menorrhagia and metrorrhagia. It may be that in these cases the condition of the blood and the state of the vessels is sufficient to account for the hæmorrhage; but some local condition is often found along with these, such as a small fibroid tumour, or a congested condition of the uterine mucosa due to displacements, which as well as the general condition require treatment. These cases are amongst the most difficult to treat, because they interact in such a way as to produce a "vicious pathological circle" — the drain on the system by the hæmorrhage tending to aggravate the very systemic condition which in its turn leads to the menorrhagia.

Many other general conditions dispose to menorrhagia and metrorrhagia. Of these are long-continued mental depression, hysteria, and other nervous disturbances; deranged states of the system due to too luxurious and too sedentary habits of life; residence in tropical climates, or in damp, unhealthy situations; malaria; tubercle; the acute exanthsms

("uterine epistaxis" associated with typhoid fever); lead and phosphorus poisoning, and Bright's disease.

Hæmorrhage, again, may be associated with disorders of the circulation. Backward pressure, especially as the result of mitral incompetence or stenosis, or a congested condition of the vessels of the pelvis, the result of pressure exerted on the veins of the portal system by new growths, is apt to produce bleeding, which like the epistaxis that sometimes appears to save a patient from a cerebral hæmorrhage, may be looked upon as a relief of congestion. In most cases of the kind, however, we may suspect the presence of a predisposing local condition in a diseased state of the uterine mucous membrane.

Cirrhosis of the liver and kidneys is a cause belonging to the same class; and when the cirrhosis itself is due to alcoholism we may find a threefold cause in hepatic cirrhosis, in a hypertrophied and dilated state of the heart, and in a diminished activity of inhibitory nervous centres or tracts.

Such are the chief general conditions which may dispose to or produce the disorder; in discussing the local causes it will be convenient to associate these with the three most important epochs in the sexual history of woman, which are (i.) puberty, and the early years of menstrual life; (ii.) the period of fertility; and (iii.) the menopause.

(i.) **Menorrhagia during Puberty and the early years of Menstrual Life.**—From what has already been said it may be gathered that in young girls the causes of menorrhagia are for the most part of a general kind. In such cases local examination, except under the most urgent circumstances, is to be avoided; and treatment ought to be directed to the improvement of the general health, and especially to the nervous and hæmopoietic systems. If in such cases local examination is indispensable it should be made by the rectum, unless vaginal examination be absolutely imperative. In either case the patient should be anaesthetised.

On the occurrence of every menstrual period, a condition of *pelvic hyperæmia*, short of actual inflammation, with its various stages of congestion, exudation, and resolution or suppuration, is established. In some cases this hyperæmia is so much exaggerated as to give rise to distressing symptoms—especially to menorrhagia—resembling those of acute inflammation of the uterine appendages. This event is not an uncommon result of the reflex irritation which accompanies the occurrence of the first menstrual period, especially in the case of girls who are brought up in refinement, and who are overtaxed at school. The fact that local irritation may dangerously increase this condition of hyperæmia must not be overlooked.

(ii.) **Menorrhagia during the period of Fertility.**—In cases of this class a local cause is more commonly to be found, even if some co-existing general condition accentuate the symptoms. In these subjects local examination must be promptly considered and unhesitatingly urged: hæmorrhage is too dangerous a symptom to admit of delay.

As in the former class of cases *pelvic hyperæmia* is the immediate cause of hæmorrhage. Local irritation may be found in the first sexual act or in excessive indulgence. Too prolonged a lactation acts in the same way, and also by lowering the general tone of the system. In these cases, unless the cause be removed, the line between mere congestion and active inflammatory changes is readily overstepped.

*Fibroid tumours*, which are a very common cause of excessive flow, probably act likewise — by an increased vascular supply to the uterus, and also by the production of an enlarged and inflamed secreting surface: thus we find excessive bleeding as a result of all enlargements of the uterus from neoplasms and from subinvolution; and of all inflammatory conditions of the peritoneal, muscular, or mucous coats. Uterine displacements, such as prolapse and flexions, are amongst the commonest causes of menorrhagia.

The excessive hæmorrhage in flexions is caused, according to some observers, by a temporary accumulation of blood in the cavity of the uterus, which causes distension and an increase of the secreting surface. As more fluid accumulates during the menstrual period, a gush occurs from time to time, so that the patient suffers from alternate retention and escape of menstrual blood. A continuously excessive flow of blood is rare in such cases: in the great majority menorrhagia occurs in gushes.

Other observers, however, believe that the menorrhagia in cases of flexion is simply the result of the endometritis, which they consider to be a constant accompaniment of displacements, an opinion with which I entirely concur. Those who support the “retention” theory apply it also to the causation of the menorrhagia of fibroids.

*Extra-uterine inflammations*, implicating the ovaries and tubes, all give rise — except in their final sclerotic stage — if not to metrorrhagia, at least to menorrhagia. *Ovarian tumours* may have the same effect, although not nearly so markedly as uterine tumours; in fact the growth of many ovarian tumours does not affect menstruation at all: yet disturbances of the circulation in the ovaries may tend to produce hæmorrhage from the uterus without apparently affecting the healthy state of this organ. *Tumours and cysts in the broad ligaments* find a place in the class of causes of congestive hæmorrhage, because they act by interference with the circulation and with the normal position of the uterus.

Another set of causes are those which directly alter the condition of the surface concerned. Endometritis has already been mentioned among the inflammations; but there is a special form of endometritis, known as *villous, or hæmorrhagic endometritis*, which gives rise to profuse hæmorrhage, and often simulates primary cancer of the fundus. Cancer both of cervix and fundus, polypi, tubercular and other ulcerations, produce hæmorrhage in great measure because of the changes they effect in the mucous membrane, such as erosion of it, and consequent implication of the superficial and sometimes even of the deep blood-vessels.

A small class of cases may be mentioned, mainly consisting, so far as my



experience is concerned, of soft, fat, flabby, anæmic women, whose menstruation, so far as sanguineous discharge is concerned, is entirely in abeyance, and is replaced by a profuse uterine leucorrhœa. This may be as exhausting as profuse hæmorrhage, and is often accompanied by colicky pains. I have never seen any local treatment to be of any benefit in such cases. Careful dieting, exercise, salines, and a course of Marienbad, constitute the most satisfactory treatment.

*Idiopathic Hæmorrhage.*—There is one form of hæmorrhage not yet mentioned which may occur during active menstrual life. It is referred to by several authors; but in these days one would almost hesitate to mention it were it not for the occurrence of cases which can be assigned to no other class, but must be collected under some such name as *Idiopathic Hæmorrhage*. I am strongly of opinion that it must be extremely rare for hæmorrhage to occur with no local or general lesion, and yet the following case, which came under my observation some years ago, is very difficult to interpret otherwise:—

The patient, a married woman with four children, whom I had known throughout my whole professional life, had menstruated regularly, but rather profusely. When thirty-eight years old, six years after the birth of her last child, she was seized, during the course of a menstrual period, with a uterine hæmorrhage so severe that, in the middle of the night, I was obliged to plug her vagina. On the occasion of her next menstruation the same method had again to be adopted to arrest hæmorrhage; and this had to be carried out time after time for five months, although the usual appropriate intermenstrual treatment by hot douching, ergot, etc., was strenuously persisted in; and on two occasions her uterus was curetted and styptics applied to the bleeding surface. Each successive menstrual period left her more and more exhausted. She was examined frequently, with the utmost care, under chloroform; but no local lesion whatever, nor any general condition could be found to account for this excessive flow. I am well aware that even the smallest polypi may cause profuse and even fatal hæmorrhage; but in this case, after dilatation of the cavity of the uterus and the most careful examination, I could find no trace of any such thing.

During the course of a menstrual period the patient died, apparently of syncope.

An autopsy was conducted by Dr. Sims Woodhead. The uterus was examined minutely, yet, except that it was slightly enlarged—to the extent of 3 inches—and contained a clot, no morbid condition was found at all. There was no neoplasm, nor any abnormality whatever in any of the coats of the uterus. In the left ovary there was a large corpus luteum. The thoracic and abdominal viscera were pronounced to be normal. The symptom in this case might have been attributed to hæmophilia; but, as the woman had presented no other indications of this condition either in her earlier or her later life, and as in her family history there was nothing to suggest such a diathesis, there was no course open but to suppose the case to be one of "*Idiopathic Menorrhagia*."

(iii.) **Menorrhagia at the time of the Menopause.**—The menopause is a period which is characterised by the occurrence of hæmorrhages.

The climacteric may manifest itself in three special ways: (*a*) the menses may cease gradually; (*b*) they may cease only after a long-continued series of hæmorrhages; (*c*) they may cease suddenly.

It is with the second of these varieties that we are more especially concerned at present. Whenever at the menopause hæmorrhages are profuse very careful local examination should be made, in order to ascertain whether the condition be due to the presence of a neoplasm, to some other local cause, or to general causes. A most important point to notice is that, after the menopause has once become established, post-climacteric hæmorrhages are almost invariably due to a local lesion, such as senile catarrh, cancer, or the presence of mucous or fibrous polypi; though cases are recorded in which this symptom has been due to sexual excitement. But it must always be kept in mind that women of a gouty diathesis not only often menstruate very late in life, but have recurrent post-climacteric discharge due to this dyscrasia.

This is not the place in which to discuss the differential diagnosis of cancer from senile uterine catarrh or fungous granulations on the uterine mucosa; but the importance of establishing a certain diagnosis, and of not postponing a local examination till it is too late, cannot be too strongly urged.

The above discussion of uterine hæmorrhage shows, at least, the importance of regarding it rather as a sign than as a disease. While on the one hand the cause of the bleeding in each case must be carefully sought out, we shall remember on the other hand that in young unmarried women the most common causes of menorrhagia and metrorrhagia are constitutional; in fertile women, subinvolution, fibroids, and displacements of the uterus; in single middle-aged women, fibroids; and in women between forty and fifty, either the usual climacteric hæmorrhages or cancer or fibroids.

**The symptoms of menorrhagia** are, of course, the symptoms and signs of loss of blood from any part. It may occur suddenly and compromise the patient's health rapidly; or it may occur gradually in increasing quantity month by month, and thus induce anæmia with its consequent results.

The hæmorrhage of a so-called hæmatocele might, no doubt, be described with some truth as an internal menorrhagia. More commonly, however, there is an external as well as an internal hæmorrhage; and as hæmatocele is now regarded as being, in the great majority of cases, due to an early ruptured extra-uterine gestation, it is not necessary to discuss the subject here.

**Treatment.**—It will be evident from the great diversity of causes that the treatment of the symptoms under consideration must have a direct reference to the cause, and cannot be indicated on general lines to suit all cases.

As we have to decide in amenorrhœa whether it be advisable or not

to bring about the hæmorrhage which is in abeyance, so in menorrhagia it is frequently not without benefit to the patient that she should lose more blood than usual, or even that blood should flow at an abnormal time, so long as the loss of blood does not markedly depress her general health. Where salpingitis or ovaritis or other inflammatory condition exists which produces congestion in the structures about the uterus, the local loss of blood may often relieve the pain and reduce the congestive condition. So, as mentioned above, in cases of backward pressure producing congestion, bleeding from the uterus may prevent congestion or bleeding at parts where it would be much more dangerous.

The treatment of the *general systemic conditions* which were first discussed obviously consists in measures tending to the improvement of the general tone. Rest in bed at the time of the flow is frequently advisable; because, apart from the fact that less blood is likely to be lost by a patient lying on her back with the hips raised than if moving about in the ordinary way, it is also the case that a patient lying still, with the head low, can lose more blood with less bodily harm accruing from the loss.

It is by such a plan as this that the menorrhagia of young girls must be treated before we resort to such means as the hot douche, or indeed to any local treatment. Mental and bodily rest, with careful feeding, are essential; and so is the administration of salines and tonic medicines. The following prescription is so commonly used in my ward that it goes by the name of "The Ward Mixture"—℞ Magnes. sulph. ℥ss.-℥j., Quininae sulph. gr. iss., Ferri sulphat. gr. v., Acid sulphuric dil. ℥x., Aq. menth. pip. ad ℥j.

But it must be further remembered that very often in cases where the condition may seem to be due to general causes, there exists also a local lesion in the mucosa, which may be the subject of fungoid granulations. In such cases curetting is often of great avail. This operation, one of no great difficulty, is described at length in another part of this work (*vide p. 292, et seq.*).

*Curetting* will be found of great service in most cases of menorrhagia and metrorrhagia. Some authors, indeed, recommend its employment even in cases where in the actual state of the mucosa it does not appear to be required; in cases, for instance, where the hæmorrhage is apparently due to nothing more than an inflamed condition of the ovaries.

With regard to general means of checking hæmorrhage it has been found that not much is to be gained by the internal administration of drugs. Out of a very large number of drugs which have the reputation of hæmostatics but very few can be relied upon: of these the foremost is undoubtedly *ergot*. It acts by causing contraction of non-striped muscle, and thus diminishing the calibre of blood-vessels: in the uterus, moreover, it causes contraction of the network of muscular fibres which form the middle coat, and constricts the vessels which pass through that network; but, so far as my experience goes, ergot acts very inefficiently on the uterus except when the muscular tissue is hypertrophied, as after

labour or abortion; or in cases of fibroid. Ergotine, especially in conjunction with strychnine or nux vomica, is perhaps the most efficient preparation. Hydrastis alone or with ergot is often of service.

Apart from its use in abortion or parturition, the administration of the drug must be long continued in order to be of any benefit. Sulphuric acid and cannabis indica are undoubtedly useful also in certain cases.

The investigations of Dr. Wright of Netley give promise of a new remedy applicable in certain cases of menorrhagia and metrorrhagia, namely, calcium chloride. The chloride is a convenient salt of calcium, because it is readily soluble in water; and calcium acts by increasing the coagulability of the blood. In cases, therefore, where the coagulability of the blood is less than normal (and Dr. Wright describes a clinical method of estimating this), the internal administration of the chloride of calcium in doses of gr. xv. would act beneficially by bringing the coagulability up to the normal point. It has been tried in cases of uterine hæmorrhage, and certainly has produced good results in some of them, both as a draught and as a local application.

Of *local applications* none can bear comparison with the use of hot water applied in the form of vaginal douches at a temperature of 120° F. Indeed, there is no better method of checking a long-continued menstruation than to douche the patient regularly with hot water. Many women object to the practice; but it is, nevertheless, a perfectly safe and satisfactory way of stopping a long-continued menstrual discharge. Experiments on the uterus in some of the lower animals have proved that hot water as a muscular stimulant is much more beneficial than cold. The contraction produced by hot water is more rapid, and, what is more important, it is continued for a longer time than that produced by cold. Moreover, it must be obvious that the effect of a hot application on the system must be much better than that of one which removes a considerable amount of heat from a body already reduced by loss of blood.

The local application of styptics, especially by means of Playfair's probe covered with cotton wool and dipped in some astringent solution, is often of the utmost value, even without any previous curettage.

Plugging of the vagina with damp antiseptic wool is often most serviceable; in exceptional cases the uterus may be packed with antiseptic gauze. It has been said that this packing may result in a dangerous regurgitation of fluid through the Fallopian tubes; but this event, so far as I know, is extremely rare, and, if it does occur, is not associated with any serious symptoms. Plugging is a good temporary method of checking hæmorrhage, and gives time for the application of measures to restore the patient's strength, and for the adoption of more permanent remedial means.

*Electricity.* — The constant current in the treatment of menorrhagia seems to me to have a specially beneficial effect in those hæmorrhages which occur at or near the menopause, when the uterus is undergoing atrophic changes. It is also useful in the subinvolutions of actively



fertile women — although I am obliged to add that in two cases thus treated subinvolution fell into superinvolution, with subsequent permanent sterility. In these cases, therefore, this method of treatment must be carried out with special precautions. It is not part of my duty in this article to pronounce upon the effects of the continuous current in the treatment of fibroids, but I may say that in specially selected cases of small fibroids, and of hæmorrhagic endometritis, this method of treatment, if carried out with care and by competent hands, frequently effects a temporary and occasionally a permanent cure [*vide art. "Electricity in Gynæcology"*].

*Removal of the Ovaries.* — As regards the treatment of menorrhagia, apart from any uterine neoplasm or general condition, by removal of the ovaries, I will give here the reports of two cases: —

1. A girl, twenty years of age, unmarried, suffered for three years from hæmorrhage to such an extent as to render her a complete invalid. When she came under my observation her menstrual flow lasted for fourteen days. At the end of her period she was bloodless, and subject to frequent faints. The uterus was curetted, and she was put under long courses of styptics and douching, with little if any benefit. As a last resource removal of the ovaries was considered and ultimately carried out. She has never menstruated since, and is now a staff nurse in a hospital in the enjoyment of perfect health.

In this case the ovaries, although somewhat enlarged and heavy, were not the subjects of any cystic or other degeneration, and the cause of her uterine hæmorrhage was not otherwise apparent.

2. Another case occurred of a somewhat similar character. A young lady of twenty-five had been married for four years, and was sterile. She bled so profusely at her periods, and occasionally intermenstrually, that she was practically bedridden. The uterus was apparently normal. She had no general disorder, and after the usual treatment by curetting, styptics, and hot douching for a long time, no improvement resulted. After careful consultation, and with the concurrence, of course, of her friends, the ovaries were removed. Since that time, ten years ago, menstruation has not returned, and she has been in the enjoyment of excellent health. The ovaries, as in the former case, were simply enlarged and heavy.

In neither of these cases was there any reason to suppose that any sexual irritation existed. Now, although I am very far from recommending such a course for frequent adoption, I mention these cases as extreme ones, needing extreme measures. No operation in gynæcology requires to be more safeguarded than that for removal of the ovaries. It is, unfortunately, an easy operation, and one far too frequently performed. I mention the above cases only as exceptional ones.

The treatment of uterine displacements, cancer, fibroids, and all other local conditions which give rise to hæmorrhage, must be sought for in other parts of the System.

**DYSMENORRŒA.** — All women, even while enjoying good health, feel “unwell,” as they themselves call it, at the menstrual period. They experience some pelvic discomfort or inconvenience associated with a general malaise, a few indefinite pains in the back and loins, and a certain irritability of temper; that a woman should not be thus affected would be almost an abnormality. However, I do not for a moment deny that some women menstruate with no trace of suffering whatever, the presence of the discharge being only an inconvenience. It is easy to understand the “normal” discomfort if the nature of the function of menstruation is considered. It is impossible to suppose that the various changes, especially the congestion, which occur during the different stages of the process of normal menstruation should take place without giving rise to a certain amount of pelvic and general discomfort. But the difficulty lies in fairly estimating the suffering of the individual, and in determining when the disorder has ceased to be physiological and has become pathological. The sensitiveness of the nervous system in women varies so much that what is described by some as an “inconvenience” by others is called “discomfort”; what is to some “discomfort” to others is “pain”; and yet others, again, who call their suffering “a little pain” endure as much as many who describe their sufferings as “agonising” or “excruciating.” One must, therefore, draw a line of demarcation between the mere discomfort of menstruation — no matter how it is described by the sufferer — and genuine dysmenorrhœa, which is graver pain occurring at or about the menstrual epoch; pain so severe as to interfere with health, with work, or with pleasure. It is not easy to lay down a hard and fast rule in the estimation of pain, which, after all, is a symptom which does not directly appeal to any of the senses of the physician. With limitations, however, it may be concluded, in the case of a poor woman who has to work for her daily bread, that if her dysmenorrhœa is not sufficient to lay her up and so to withdraw her from her duties, then her suffering requires no special local treatment; in the well to do, if the pain does not deprive the sufferer of her social enjoyments and amusements, it likewise calls for no special local treatment. In these cases even a vaginal examination, at any rate in the unmarried, should not be undertaken, or at all events not without a prolonged trial of general remedies and management. But there is no doubt a very large number of women who constantly demand and deserve our attention on account of menstrual suffering. Their pain is not the mere discomfort of all women, nor the temporary severe pain of many, but a prolonged agony; in some cases so extreme as to render life a burden for years. No sooner has the pain of one epoch passed than they begin to dread with horror the next; and so life is rendered miserable. The disease, or rather the symptom, seldom leads directly to death; but it does interfere to a very large extent with fertility, health, and happiness. With such a state of things one has frequently to deal in practice, perhaps more frequently than with any other disorder of menstruation; and, further, the reflex and sympathetic disorders associated with dysmenorrhœa — the mental and nervous

derangements — are many. These neuroses, due mainly to changes in the ovaries, are well recognised, and must be carefully considered in dealing with dysmenorrhœa.

There is no very definite relation between the amount of flow and the degree of dysmenorrhœa: although in many of the spasmodic and membranous forms, as we shall see further on, the discharge is often scanty, yet it is often profuse in the ovarian and tubal forms, in both of which the pain is equally well marked. Perhaps, on the whole, uterine dysmenorrhœa is more marked when the menstruation is scanty than when it is profuse.

In some women the dysmenorrhœa begins with puberty and, unless active treatment is adopted or pregnancy occurs, it continues all through adult life: in others it arises only after some distinct exciting cause, such as a chill, or under conditions which give rise to inflammatory or other changes in the uterus or its appendages. No doubt dysmenorrhœa is commoner among unmarried women, but sometimes it sets in only after marriage. When met with in married women it is frequently associated with sterility; and it is certainly less frequent among parous women than in the nulliparous.

**Dysmenorrhœa and Sterility.**—Some relation between dysmenorrhœa and sterility has been observed frequently enough. In many cases the association is accidental. So far, indeed, as I am able to judge, the association of dysmenorrhœa with sterility is not so close as is generally supposed.

Kehrer, who has gone into this matter at some length, has shown that a history of painful menstruation before marriage is only slightly more common in sterile than in fertile women. Kammerer gives a table of 408 cases of sterility, in 67 of which dysmenorrhœa was a prominent symptom; Jackson gives a table of 72 cases of sterility, in 16 of which dysmenorrhœa was a prominent symptom. Certainly, on reflecting upon my own experience, I should not be inclined to give dysmenorrhœa a prominent place in relation to sterility. Obstructive dysmenorrhœa, putting the term conversely, and regarding various conditions of the uterus as obstacles to conception, scarcely appears to me to have any foundation: in fact, as Jackson says, "The obstacles which are overcome by spermatozoa in their progress towards the uterine cavity are, to say the least, remarkable."

The view which commends itself to me is that, in cases of dysmenorrhœa associated with sterility, the explanation of both conditions is to be sought for rather in general congestion of the pelvic organs, more especially of the endometrium, than in any mechanical cause. The dysmenorrhœa is accounted for by a hyperæmia; and the sterility, not by any mechanical interference with conception, but rather by some condition of the endometrium which interferes with the continuance of gestation. In other words, the dysmenorrhœa is due to congestion of the uterus associated at times with spasm of the os uteri internum; and the sterility to a hyperæmic and hyperæsthetic state of the endometrium.

Such a view as this explains how it is that, after treating various conditions of apparent mechanical obstruction—such as ante-flexion, stenosis, and so on—the sterility continues. A very large number of the processes concerned in generation are, no doubt, wholly mechanical; and it is not surprising, therefore, that in cases of sterility which present some apparent obstacle of a mechanical character, this obstacle should be promptly accepted as the efficient cause, and mechanical means adopted for its relief. It is certain that the cure of an ante-flexion or a retro-flexion, or in other words the removal of causes apparently mechanical, has resulted in the cure of dysmenorrhœa; and we have learned clinically that it has sometimes been followed by a pregnancy. Far oftener, however, these mechanical means, while relieving the dysmenorrhœa, have failed entirely to remove the sterility,—failed, no doubt, because they did not remove some condition other than the mere narrowing of the cervical canal; such a condition seems to me to be a morbidly hyperæmic state of the endometrium, which renders the grafting of the ovule an impossibility.

*The Varieties of Dysmenorrhœa.*—The classifications given by different authors are endless, but many of them have been framed upon erroneous notions of the nature, firstly, of menstruation, and, secondly, of dysmenorrhœa. For example, many arrangements have been suggested on a purely mechanical or obstructive view of the causation—as if due to displacements, stenosis of the cervix, and so on; and while these are, no doubt, elements in the causation, yet some deeper cause underlying it all, underlying all the varieties and forms, must be looked for. The initial difficulty in discussing dysmenorrhœa lies in our ignorance of the ordinary physiology of menstruation. I cannot here discuss the various theories of menstruation, they must be sought elsewhere; but I may say briefly that in all varieties, no matter where the exact origin of the pain may be, the essence of dysmenorrhœa is *congestion*.

It is easy to make a primary classification of the varieties of dysmenorrhœa—one which probably no one will dispute—namely, to divide the various forms, clinically, into (I.) Uterine; (II.) Extra-uterine. This classification is based upon a clinical consideration of the nature of the pain, and of the organs primarily affected.

Others have classified the varieties as *primary* and *acquired*; and this arrangement no doubt is occasionally useful. Primary dysmenorrhœa is that form which sets in at early puberty and continues into adult life. It is found associated with defective development, and leads subsequently to the spasmodic form of dysmenorrhœa. Acquired dysmenorrhœa is found in young women after attacks of the exanthemata, or after chills; in parous women it follows sepsis after an abortion or a full term labour, and so on.

It is not now matter for dispute that a uterine and an extra-uterine form of dysmenorrhœa exist; but difficulties arise as we recognise that the varieties are very often mixed; and still greater difficulties are met with when we attempt to arrange the different causes, especially of uterine dysmenorrhœa. The difficulty, however, does not lie in the clinical



distinction of the forms, but rather in the proper naming of each kind. Different minds are apt to associate different meanings with the same word, and hence confusion arises.

Four factors, roughly speaking, are concerned in the production of dysmenorrhœa: 1st, Some morbid condition in the shedding off of the mucous membrane in whole or in part, seen in its most pronounced form in membranous dysmenorrhœa. In a state of health the process of disintegration, I apprehend, takes place with little trouble; but if, on the other hand, from some such cause as the changes produced in the mucous membrane by long-standing inflammation, the process be retarded, centres may be furnished for the formation of clots; and these increasing in size and becoming foreign bodies, lead to violent intermittent contractions. 2nd, The consequent difficulty and pain of the uterine contraction; which are still more marked if the uterine muscle be the seat of any inflammatory change. 3rd, Some obstruction to the outflow of the uterine discharge, leading subsequently to retention and congestion. 4th, and lastly, these local conditions, themselves a source of local pain and discomfort, may be aggravated in each individual case, according to the nervous constitution of the sufferer. In other words, the whole condition is one of hyperæmia and hyperæsthesia.

**I. Uterine Dysmenorrhœa.** — A. *From defective development and obstruction.* — The first class of cases of uterine dysmenorrhœa to which I would refer is that associated with defective development. The uterus after puberty in such cases continues in a more or less infantile condition: such a uterus is frequently found in young chlorotic girls, and it is associated with a marked form of dysmenorrhœa. An undeveloped organ performs its function badly, and the uterus is no exception to the rule. Ill development has been specially studied by Sir John Williams, and the connection between this condition and dysmenorrhœa has been particularly emphasised. It has further been pointed out that the younger the sufferer from painful menstruation the more defective the development of the pelvic organs.

Into this class of cases we may fairly admit the dysmenorrhœa of young women who suffer from a displacement, especially from anteflexion of the uterus. The position is, however, nothing more than the persistence of the normal condition of the child; in short, it is a defect of development. This unripeness of the uterus may show itself in other ways than in a flexion of the body of the cervix. Frequently stenosis of the os is an indication of ill development; and when either a flexion or a stenosis, or both exist, dysmenorrhœa, frequently called obstructive or mechanical, is the most prominent symptom of the existing condition. But while not denying the possibility of a purely obstructive dysmenorrhœa from narrowing of either os, or of the whole cervical canal, I venture to say that uncomplicated cases are very rare. Mechanical obstruction causing pain is possible at the beginning of menstrual life; but ere long a secondary congestion, and even actual inflammatory changes from retention of menstrual flow, are an inevitable result.

There are many objections to the "mechanical theory" of dysmenorrhœa. It has been urged that if blood can flow through a capillary tube no os or cervical canal, however narrowly contracted, can offer a positive obstruction; and it is further pointed out that many women with most marked flexion and a pin hole os menstruate with no abnormal discomfort. These and other objections are no doubt potent in many cases, and I believe that, in a case of any standing, an inflammatory condition must be superadded to the obstruction; so that most of these cases would be grouped in the second class of uterine dysmenorrhœa to be mentioned later. I do not wish it to be supposed that cases are frequent in which the only signs to account for the dysmenorrhœa are a flexion or a stenosis without any indication of excessive congestion or inflammation to account for the symptom. The chief symptom of congenital ante flexion is undoubtedly dysmenorrhœa characterised by violent pains in the loins while the blood distends the body of the uterus — the part, that is, above the point of flexion; suddenly the obstacle is overcome and the collected menses, partly fluid and partly in clots, are expelled. The purely mechanical theory of dysmenorrhœa, since it was made known by Simpson and Sims, has been accepted by most authors. It is rejected, however, by Champneys and by Fritsch; the latter explains the pain as due to irritation from congestion; the abnormal vascular tension, the result of the interference with the circulation in the vessels at the point of flexion, irritates the nerves of the uterus and so causes the pain. However, the paroxysmal and alternating character, both of the pains and of the discharge, almost compel one to consider the obstruction to an easy flow as of vital importance.

It has even been suggested that, as the result of ante flexion and consequent obstruction, a few drops of blood are every month forced along the Fallopian tubes into the peritoneal cavity, and give rise to a periodic and miniature hæmatocele. These small internal hæmorrhages are considered by some observers to be the cause of the posterior perimetritis which sometimes accompanies ante flexions; and this inflammatory condition would account for the acute febrile phenomena with which the dysmenorrhœa of ante flexion is sometimes associated.

*B. Spasmodic and Inflammatory.* — Cases in the previous group, as age advances, frequently merge into a second class of uterine dysmenorrhœa, namely, the spasmodic and inflammatory.

The continuance of the mechanical form leads, sooner or later, to hyperæmia and thence to subacute inflammation; thus the so-called "spasmodic dysmenorrhœa" is established. This very well recognised form of dysmenorrhœa is the result of spasm, not only of the uterus, but of the os internum, occurring in an organ subacutely inflamed. Whether the subacute inflammation be due to the retention of clots in a displaced uterus, which act as foreign bodies and cause congestion and spasm; or whether it be due to an alteration in the circulation of the uterus caused by the flexion, is a matter which scarcely admits of definite settlement. Though this form may sometimes be primary, due to any cause which

may lead to accidental congestion or inflammation of the uterus, it is, as we have seen, usually secondary to a dysmenorrhœa, arising from defective development or simple obstruction.

The dysmenorrhœa associated with fibroid tumours of the uterus may also be included in this class. No doubt many of these cases may be attributed to the obstruction which the tumour offers to the easy escape of blood; but in most of them the inflamed condition of the uterine mucosa which invariably accompanies the neoplasm is the cause of the suffering.

Many describe as "constitutional" a gouty, a rheumatic, and a neuralgic form of menstrual pain. But all these, I believe, are associated at least with congestion of the uterus, and many with a marked sub-acute form of inflammation; they are therefore included in the present class. The dysmenorrhœa in such cases is simply the evidence of an inflammation similar to that which occurs in other organs of those who are the subjects of such diatheses. That this kind of dysmenorrhœa is common there can be no reasonable doubt. How else are we to account for the persistence of dysmenorrhœa in members of the same family? How else are we to account for the persistence of sterility associated with dysmenorrhœa in members of the same family? I have frequently seen families in which the daughters were all dysmenorrhœic and all sterile. Now in such families I believe that the dysmenorrhœa is due to gouty or rheumatic inflammation of the endometrium, with a resulting spasm of the os uteri internum; and that the sterility is due, not to interference with conception, but rather to the congestion of the mucous membrane which thus forms a bad nidus for gestation.

*Symptoms.*—The situation of the pain is usually in the neighbourhood of the pubes. The pain is described by the sufferer as "bearing down," and comes on in spasms, intermittently. It resembles colic of a severe type. The pain lasts for the first day, and, indeed, until the discharge is distinctly established, when relief is obtained. The actual flow may be scanty, but it is generally accompanied by clots. The severity of the pain varies; it is sometimes so severe as to be associated with nausea, vomiting, and utter prostration. Occasionally the suffering recurs on the second or third day, owing no doubt to the attempts of the uterus to expel accumulated clots.

Spasmodic dysmenorrhœa has no tendency to spontaneous cure, but, unless the patient be subjected to appropriate treatment or become pregnant, it becomes more and more aggravated as time goes on. When pregnancy does occur, and goes on to full term, the patient is usually cured.

The *diagnosis* of these cases must be accurately made, because upon accurate diagnosis depends efficient treatment.

Of course it occasionally happens that a spasmodic dysmenorrhœa is associated with other kinds; but when the condition is simple it is to be recognised: 1st, By the fact that the pain occurs in the first twenty-four or forty-eight hours of the menstrual period; 2nd, that there is no

appreciable change in the uterine appendages; and, 3rd, that the uterus is freely movable, and usually flexed either anteriorly or posteriorly. When such a state of things is ascertained, treatment is satisfactory.

*Treatment.* — This resolves itself into — 1. Palliative, which applies to all forms of dysmenorrhœa; 2. Radical.

1. Palliative Treatment. — This consists, first of all, in dealing with any general condition, such as anæmia, gout, or rheumatism, — maladies to be treated by iron and arsenic, colchicum, and the salicylates respectively. In the second place, the treatment of the actual pain is to be conducted first of all, and mainly, by pelvic depletion. Anything that depletes the pelvis proportionately diminishes the hyperæmia upon which the pain depends; and, therefore, the free use of salines before the periods is of the utmost value. Very often, in anæmic women, a continued use of chlorate of potash, iron, and *actæa racemosa*, used in combination for a week before and during the period, will give much relief.

For the actual suffering, antipyrin, phenacetin, and the other coal tar derivatives of this group, will be of service; *pulsatilla*, also, either as the tincture in five minim doses every hour, or combined with *caulophyllin*, is most useful; in my experience it has been eminently satisfactory. When the pain is excessive nitrite of amyl or nitro-glycerine may be administered with advantage.

Such peripheral sedatives as *cicuta verrosa* and castor are useful. Undoubtedly opium and alcohol give the most prompt and efficient relief; but their temporary employment may become a permanent habit, and therefore they are to be employed with the utmost caution. Diaphoretics, warm hip baths, sinapisms, and hot drinks will all relieve the distress to a certain extent.

2. Radical Treatment. — In cases of defective development in young girls nothing beyond palliative treatment is to be attempted. But when the case is obstructive, or primarily or secondarily spasmodic, then the local treatment is clear and definite; and, as a rule, if undertaken carefully, is entirely satisfactory. If the manipulations to be described are carried out with careful and antiseptic precautions, and there be no peri-uterine disturbance, an absolute cure can in most cases be anticipated.

In dealing with a case of spasmodic dysmenorrhœa which resists the ordinary palliative treatment, and where the symptoms are sufficiently severe, a vaginal examination ought to be made under chloroform; if the uterus be found freely movable — anteflexed or retroflexed as the case may be — and the uterine appendages healthy, the indications for treatment are obvious. There are several alternative means: the first and best is as follows. Under anæsthesia the cervix, fixed by a volsella, should be gradually dilated by a series of bougies, either metallic ones or those of Hegar; in a few cases the mere passage of the uterine sound immediately before a period is sufficient to relieve the pain. Secondly, as an alternative, the cervix may be rapidly dilated by Sims' or Ellinger's dilators. Either of these methods will in most cases be found satisfactory.



The operation, however, has to be repeated frequently. Thirdly, if the flexion backwards or forwards be very acute, a stem pessary may be found useful. I am well aware of the risk of using these instruments, but, with due care and precaution, excellent results may be obtained, even in some persistent cases.

It is essential that immediately after the introduction of the intra-uterine pessary the patient should be kept in bed and carefully observed for some days. As a rule the introduction is speedily followed by spasmodic pains in the uterus, but these soon subside. Occasionally, however, a more serious pain results, that of pelvic peritonitis; and should there be the slightest indication of this the stem should be removed instantly. It is almost impossible to determine beforehand whether a uterus will tolerate the introduction of a foreign body. Some wombs are extremely tolerant, others will not endure the slightest mechanical interference without inflammatory reaction. Before one ventures to use a stem pessary it should be determined that the uterine appendages are perfectly healthy; the personal equation of the uterus also should be estimated, so far as possible, by the frequent passage of the sound. If the stem pessary can be worn without discomfort, the patient may get up after a few days, and after a week or two a larger stem may be substituted. The cases which, as a rule, are most satisfactorily treated by this method are those of aggravated congenital flexion. The patient should not be subjected to the risk of a stem pessary until all other means have failed, and then only with the utmost caution.

One other method of treatment of this form of dysmenorrhœa remains; but it may be dealt with shortly, as within recent years it has fallen into desuetude, at any rate in this country.

Sir James Simpson was the first to advocate the *division of the cervix*; and he was led to adopt this method by the common observation that dysmenorrhœa is much less frequent in parous women than in the nulliparous. Acting on the supposition that the shape of the cervical canal is important in the causation of the menstrual pain, he so divided the lips of the cervix that its condition in a non-parous woman approximated to that of one who had borne children. The operation is performed with the metrotome or with Küchenmeister's scissors.

Sometimes the operation, instead of being a bilateral one as advocated by Simpson, is single; and either posterior or anterior according to the flexion: the object in view being to straighten the canal distorted by the displacement. But the operation of division of the cervix is by no means a safe one. Putting aside the risk of sepsis, the hæmorrhage is frequently most alarming, so much so that if it is to be performed, previous ligation of uterine arteries, or at least of the lower branches, is now considered necessary. Very few operators, however, now employ the method.

For the treatment of uterine dysmenorrhœa *by electricity*, the reader is referred to the article by Dr. Milne Murray in another part of this work. The third form of uterine dysmenorrhœa is that known as —

C. *Membranous Dysmenorrhœa*. — Morgagni (23) first noticed a kind of dysmenorrhœa in which at each menstrual period, or at every second, third, or fourth period, a distinct membrane is shed from the uterus during the flow which is accompanied by severe dysmenorrhœa. If one accepts the desquamation theory of Sir John Williams, membranous dysmenorrhœa is easily explained; and, similarly, if the hypothesis of Englemann be correct — that during menstruation a proliferated mucous membrane is shed — then we can say that membranous dysmenorrhœa is merely an exaggeration of a normal process, and that the membrane is discharged in mass instead of in minute particles.

This curious affection was formerly supposed to be inflammatory; and the shed membrane was compared to the inflammatory exudation cast off from the respiratory passages during an attack of eroup. But for many years it has been known that we have to deal not with an inflammatory exudation, but with an exfoliation of the mucous membrane of the uterus. This resembles the early decidua in every respect and, like it, is a triangular-shaped sac with three openings, rough and irregular on the outer surface, smooth on the interior. Examined microscopically, the membrane possesses the complex structure of an hypertrophied endometrium, and contains follicles, nucleated cells, and blood-vessels. Sometimes the membranous sac is cast off entire, but more commonly it is shed in pieces. Occasionally only the superficial layers of the mucous membrane are cast off; much more commonly the membrane is thick, and represents the whole thickness of the hypertrophied and swollen endometrium.

Virchow says that, on examining the uterus after death in women who have died while suffering from dysmenorrhœa, he has found the mucous membrane in process of separation. Wylie says that if it be accepted that a cellular disintegration takes place during normal menstruation, it is possible to imagine that if this degeneration take place in the deeper layers of the mucous membrane, before the breaking down of the more superficial layers, these latter might be thrown off as a membrane.

It would appear that the membrane expelled belongs to, or is the product of the former menstrual period. If normally the mucous membrane is thrown off during the latter days of the flow, it would seem that in these cases of membranous dysmenorrhœa the exfoliation is postponed; and the membrane continues to grow during the intermenstrual period.

Hausmann adopted the view that these membranes are early abortions; but, although the membrane is not distinguishable from decidua, the repeated occurrence and the absence of the villi of the chorion make a distinction between them, as a rule, comparatively sure.

*Symptoms*. — The condition is peculiar to married women, although minute shreds are observed in single women. The membrane is cast off on the second or third day of the flow, as a whole, or at any rate in tangible pieces, every month, or every second, third, or fourth month. The discharge is accompanied by severe colicky pains which are sometimes of a most violent nature. The flow may be excessive or normal in quantity;

but it frequently presents an intermittence, due probably to the plugging of the os internum by the membrane. The patients are sterile, and this state is due to the mucous membrane being so altered pathologically that it does not form a suitable nidus for the ovum. Membranous dysmenorrhœa is frequently associated with other uterine disease, such as uterine catarrh or displacements; but these alone do not account for its existence.

The prognosis is uniformly unfavourable, as in most well-marked cases it continues during the menstrual life of the patient.

*Treatment.* — Any existing complication should, of course, be removed: and thereafter the dysmenorrhœa is best treated by free dilatation of the cervical canal, curettage of the uterus, and the application of strong escharotics to its interior. Intra-uterine drainage, too, has sometimes been followed by fairly satisfactory results. If these means fail, and the patient's suffering continue, the alternative of removal of the appendages, so as to induce premature menopause, would have to be considered.

Internally no medicines have a better effect than the continued use of arsenic, iodide of potassium, and mercury.

**II. Extra-uterine Dysmenorrhœa.** — The extra-uterine variety of dysmenorrhœa is that which has its origin in some abnormal condition of the uterine appendages. It is commonly called "ovarian," but in many cases the cause of the pain lies in the Fallopian tubes, or in the pelvic peritoneum in the neighbourhood of the ovary.

This form of dysmenorrhœa is associated with a very definite set of *symptoms*, and it may occur either in the single or married woman: it is found, however, more frequently in married or parous women than in the single, for reasons we shall presently see. The ovaries and tubes in young women may become the seat of inflammatory changes, as the sequela of any of the exanthemata, or as an after result of influenza, or, at times, as the consequence of a direct chill. At other times, again, they may become thus affected in young women by an inflammatory process spreading from neighbouring organs. In married or parous women, while these influences may be at work in producing a salpingitis or ovaritis, or a combined salpingo-ovaritis, yet in these there are other factors more prominently at work; the first of them is the spreading of sepsis into the uterine appendages as the result of abortion or parturition.

In these cases, if the inflammatory process be at all well marked, and more especially if, as is generally the case, it affects both sides, the usual results are acquired dysmenorrhœa and sterility. Now such a condition can be quite well recognised clinically, though it may present different features in various cases. For example, one or other ovary may be simply enlarged, tender, and prolapsed low down into the pouch of Douglas; of the two ovaries the left suffers most. Again, the tube may be enlarged and thickened, or may be the seat of one of the grosser lesions, such as hydro-, pyo-, or hæmatosalpinx; or the appendages on one or both sides may be matted together by perimetritic effusion and deposit. Further, there is a cause, but too frequent, both in single

and married women, of inflammatory disease of the uterine appendages; namely, the infection from gonorrhœa. Yet another source of infection is, unfortunately, well enough known; a salpingo-ovaritis may very easily be set up as a result of ill-managed operative interference on the uterus itself, by the improper or injudicious use of instruments, and by the disregard of antiseptic precautions.

It must be obvious that no such condition of salpingo-ovaritis can be present to any extent without implication of the uterus in the inflammatory change; hence it comes that under these conditions a mixed form of dysmenorrhœa is met with: the symptoms are sufficiently definite, however, to indicate the tubal and ovarian origin of the pain. It is no part of my present duty to describe the symptoms in general to which tubo-ovarian inflammation gives rise, among which are constant pelvic pain, menorrhagia, pain during defæcation, dyspareunia, and, especially dysmenorrhœa. Now this dysmenorrhœa manifests itself in a characteristic way. It is essentially premenstrual, that is to say, the constant pelvic uneasiness of which the patient complains passes into definite suffering and pain from three to six days before the external manifestation of menstruation. If the uterus be but slightly implicated the patient sometimes gets relief on the onset of the hæmorrhage; but, on the other hand, if the endometritis be marked, or the salpingo-ovaritis of a high degree, the pain will probably continue all through the period. This pain is mainly confined to the region of one or other ovary, and is often so severe as to keep the patient in a state of unrest for days before menstruation sets in.

The reason of this premenstrual pain is that the tubes and ovaries, already in a chronically inflamed state, become gradually more and more congested as the day of menstruation approaches; thus when the flow is established in many cases, and the congestion reduced, a corresponding relief is obtained; and the patient, although never absolutely free from pain, remains comparatively well for ten days or a fortnight after her period.

The *prognosis* is essentially bad. Perhaps, next to membranous dysmenorrhœa, this variety is the most difficult to cure. In the form affecting young girls the results are decidedly more satisfactory than in those women in whom the disease is directly the result of abortion, parturition, or gonorrhœa. Further, one main element in the prognosis is the ability of the patient to obtain the advantages of long rest and prolonged treatment. Yet in any case, so far as the cure of the dysmenorrhœa is concerned, the prognosis must always be very guarded.

In this, as in all other varieties of dysmenorrhœa, there are *two methods of treatment* — the *medical and the surgical*. With regard to the medical treatment; as the constant cycle of changes, through which the uterus and its appendages are month by month passing, is one of the most important factors in the delay of cure, it is clear that the patient must be withdrawn from any conditions which might accentuate these changes. Hence the first provision is complete rest — mental,



physical, and sexual. This must be associated with those remedies which reduce hyperæmia and discuss deposits. First and foremost comes systematic hot douching, accompanied by the introduction of ichthyol, either as a pessary or as a dressing, into the vagina. I know of no drug which has a more powerful local effect, and I am confident that its persistent use has saved many an ovary from the surgeon's knife, but its use must be persistent. To paint the roof of the vagina with iodine (half-and-half tincture and liniment) twice a week, and to place an occasional blister over the brim of the pelvis, will facilitate the cure. Internally liquor hydrargyri perchloridi, with iodide of potassium and saline purgatives, will be found beneficial.

It is obvious that such treatment will in any case be tedious, and more or less so according to the severity of the inflammation: thus it must be evident that such treatment is obtainable only by the comparatively well to do; and even in them, when the condition has become chronic, a complete cure is by no means frequently met with. In these patients, after the treatment has been carried out at home for some months, a course of baths at Woodhall Spa or Ems will be of much value. For the palliative treatment of the dysmenorrhœa proper most of the drugs to which I have already referred will give temporary relief. Yet it comes about that under three possible circumstances, surgical treatment has in many cases to be taken into consideration: these circumstances are — (a) longstanding and intractable dysmenorrhœa; (b) various mental and nervous phenomena, said to be associated with dysmenorrhœa; and (c) inflammatory or grosser lesions in the uterine appendages associated with dysmenorrhœa and other symptoms.

I think there are few cases, if any, in the first set in which the procedure can be recommended, as most kinds of uterine and extra-uterine dysmenorrhœa can be palliated without recourse to oophorectomy. It is only justifiable when the dysmenorrhœa is associated with the other well-marked symptoms to which tubal and ovarian disease gives rise. The operation, as a rule, is an easy one, and is undertaken too often on insufficient grounds. Further, even after oophorectomy a cure is by no means uniformly obtained, because, as I have already said, the menopause is not invariably induced; the patient often menstruates regularly, and sometimes even with pain: moreover, though menstruation may cease, periodic monthly pain may recur for a year or two at least. In all cases removal of the ovaries should not be adopted until all other means of treatment have failed; and then only as a last resource.

INTERMENSTRUAL PAIN. — There is a form of dysmenorrhœa, if so it may be called, which occurs, not at the time of the external manifestation of menstruation, but at mid-term; to this condition the Germans have given the more appropriate name of "Mittelschmerz"; the French, less felicitously, the name of "Dysmenorrhée intermenstruelle." Whatever name may be applied to it — and certainly intermenstrual dysmen-

orrhœa is not a suitable one — the condition in which an attack of dysmenorrhœa proper is simulated, without, necessarily, any external hæmorrhage, is well ascertained. It does not at all resemble the premenstrual pain, or the continued pain associated with inflamed or diseased ovaries; but it is a condition which occurs definitely each month, at a definite period, and for a definite number of days.

So far as I am aware, the condition was first of all described by Sir William Priestley many years ago; it has been also discussed by Fasbender and Sorel.

The four cases recorded by Priestley had the following as their prominent features: pain, paroxysmal, in the region of the ovary, occurring during the intermenstrual period; in some cases continuing up to the commencement of the flow, in others stopping before it; the ordinary flow is usually scanty, but regular, and with no pain. In two cases a tumour was felt, on bimanual examination, in the region of the broad ligament, adherent to the uterus, elastic to touch. In the other two cases only thickening in the region of the broad ligament was found.

Sorel records a case presenting symptoms similar to those mentioned above, in which the condition had existed for a great number of years; indeed, it had been observed during a period in which 147 menstrual epochs had occurred. The chief conclusion arrived at by this author was that the occurrence of the intermenstrual pain bore a more definite relation to the commencement of the period which followed it than to the period which went before; as fourteen days always elapsed between the occurrence of the pain and the commencement of the menstrual period.

One of the most important contributions to the very scanty literature of this subject is an article by Heinrich Fasbender, in which he expresses his view of the etiology of *Mittelschmerz* as follows:—Accepting Pfüger's theory of menstruation, we have in some cases a premature summation of nervous stimuli in the ovary, with the occurrence of ovulation, caused either by a delicately organised and excitable state of the whole nervous system, or of the nerves of the ovary; the latter state produced by a pathological condition of the ovary. This abnormal irritability, leading to dehiscence of a follicle some fourteen days before the proper menstrual period, produces the congestive condition of the pelvic organs found in cases examined at such a time.

"*Mittelschmerz*," with a slight flow of blood, is also described by Herr Benicke as occurring in a case where there existed a conical cervix with pin hole os, anteflexion of the uterus, and retraction of the utero-sacral ligament.

From the above notes along with my own recorded cases (8), the condition, it seems to me, can be well considered under three different manifestations: (a) A group of cases in which there is no external discharge at all. (b) Those cases where the pain is associated with an escape of blood. (c) Those in which, as in two of my cases and some of the others, the intermenstrual pain is associated with a clear discharge.

It would be absurd to dogmatise upon the causes of this condition; or to lay down any hard and fast rules as to the pathological conditions necessary to its production: but it seems to me that the above classification gives a fair insight into the different states that may lead to the production of this somewhat unusual symptom. (a) Of those cases where no external manifestation accompanies the occurrence of "Mittelschmerz," the explanation is probably to be found in the fact that ovulation and menstruation do not in these cases occur simultaneously; and that, in addition, owing to thickening of the capsule of the ovary or some such cause, dehiscence of the follicle is attended with pain. (b) Those associated with escape of blood. In all of these it will be observed that more or less endometritis, antelexion, and enlargement of the uterus were present; and, so far as I am able to judge, these were simply cases in which a slight intermenstrual flow, due to endometritis, was accompanied by well-marked pain during the passage of clots. Such a condition is well recognised and common, and scarcely, I think, should come under the category of "Mittelschmerz" at all. Still, it adequately enough describes a set of cases to which the Germans especially have drawn attention. (c) Lastly, in those cases in which a leucorrhœal discharge occurs with the "Mittelschmerz," and in which, just before the usual date of the occurrence of the pain, a swollen and fluctuating condition of the tubes was in some cases made out, I think there can be no question that the cause of the intermenstrual pain was to be found in hydrops Fallopii, reaching its full development at mid-term.

I am well aware that much doubt is now thrown upon the possibility of what is called "intermitting hydrosalpinx," or "hydrops tubæ profluens" — the occasional sudden escape of fluid through a temporarily patent uterine end, with disappearance or diminution in size of the tubal dilatation. According to some authors, it is much more likely that these discharges pass away, not by the cervix, but by a vaginal fistula communicating with the cyst. Either explanation is compatible with this view of mine.

In the cases I have recorded (8), in which a removal of the tubes and ovaries brought about a cessation of the "Mittelschmerz," it may be urged that the pain had been ovarian, and that its cessation was due not to the removal of the hydrosalpinx, but to the removal of the ovary. Here I would remark that colicky pain in the tubes does occur in such a condition, contractions of the sac forcing the fluid through a uterine orifice only partially closed; and also that pain may be due to discharge of uterine contents, the result of reflex contraction of a necessarily congested uterus. Thus it is more than likely that the pain is really tubal.

## REFERENCES

1. ALLBUTT, T. CLIFFORD. *Med.-Chir. Trans.* 1865-6, xlix. 161-164.—2. BEAU, DE. *Amer. Med. Journ.* vol. xi.—3. BENICKE. See Fasbender, No. 29.—4. BOUCHART. *Gazette des Hôpitaux*, November 1876.—5. CAMPBELL. *Northern Journal of Medicine*, 1845.—6. CHAMPNEYS. "On Painful Menstruation," Harveian Lectures, 1890.—7. COOK, W. *Med.-Chir. Trans.* 1813.—8. CROOM, H. *Edin. Med. Journ.* 1896, vol. i.—9. CZEMPIN. *Zeits. f. Geb. und Gyn.* Bd. xiii. Heft 2.—10. ENGLEMAN. *Amer. Journ. Obstet.* vol. viii. 1875-6, p. 30.—11. FASBENDER. *Zeits. für Geburtshülfe u. Frauenkrankheiten*, 1876.—12. FRITSCH. *Die Lageveränderungen und die Entzündungen der Gebärmutter*. Stuttgart, 1885.—13. HARDING, C. *Lancet*, 1879.—14. HARLE, C. E. *Brit. Med. Journ.* June 1880.—15. HARRIS, *Amer. Journ. of Obstetrics*, vol. iii. p. 616.—16. HAUSMANN. *Berlin Beit. zur Geb. u. Gyn.* 1872, S. 155.—17. KAMMERER. *Trans. New York Acad. of Medicine*, 1866-9, iii. pt. 7, pp. 1-10.—18. KEHRER. *Zur Sterilitätslehre Beitr. z. klin. Geburtsch.* 1879-80, ii. 76-139.—19. JACKSON. "On some Points connected with the Treatment of Sterility," *Tr. Amer. Gyn. Soc.* iii. 347-362, 1879.—20. JONES. *Amer. Journ. Obstet.* 1887, vol. xx. p. 92.—21. LUCAS, C. *Clin. Soc. Trans.* 1888.—22. LUSK. *Amer. Journ. Obstet.* 1891.—23. MORGAGNI. *De Sedibus et Causis Morborum*, 2 vols. Venet. 1762.—24. POZZI. *Traité de gynécologie clinique et opératoire*.—25. PRIESTLEY, Sir W. *Brit. Med. Journ.* 1872, ii. p. 431.—26. SIMPSON, Sir J. *Med. Times and Gazette*, 1859, i. p. 179.—27. SIMS. *The Lancet*, 1865, vol. ii. p. 42.—28. SMART, R. B. *Med.-Chir. Trans.* 1858.—29. SOREL. *Archives de Tociologie des Maladies des Femmes*, 1887.—30. VIRCHOW. *Gesam. Abhandlungen*, 1855, S. 774.—31. WILLIAMS, Sir J. *Obstet. Journ. of Great Britain and Ireland*, 1875, vols. ii. and iii. 1877.—32. WRIGHT. *Brit. Med. Journ.* 1893.—33. WYLIE. *A System of Gynæcology by American Authors*, 1887.

J. H. C.

---

## DISEASES OF THE EXTERNAL GENITAL ORGANS

**HYPERÆMIA.** — **Active or arterial hyperæmia** is usually the first stage of inflammation. It occurs in infants from want of cleanliness, and in older children and adults from mechanical or chemical irritation; such as masturbation, scalds, and strong chemical applications. An important cause, from a medico-legal point of view, is the rape of young children, which is usually followed by much congestion and swelling, but seldom goes on to inflammation.

**Passive congestion or venous hyperæmia** results from obstruction to the venous circulation in liver, heart, or lungs; also in pregnancy. Prolonged venous congestion may lead to permanent varicosity of the veins. Passive congestion may cause œdema of the labia majora, both labia becoming swollen, white, shining, and translucent. In inflammatory œdema the swelling is usually unilateral, and involves the lesser, as well as the greater labium.

**Treatment.** — The treatment of passive congestion should be directed to the cause of it. In pregnancy it may often be relieved by a suitable abdominal belt, and by the recumbent posture. Should the skin break special care is necessary to prevent septic infection; such cases are especially liable to erysipelatous inflammation.



**INFLAMMATIONS.** — The characteristics of inflammation of the vulva vary, not only with the irritant which causes it and the condition of the affected parts, but also with their anatomical structure; so that inflammatory affections can be divided into those which affect the mucous membrane, the skin, and the glandular structures respectively. In practice, however, it will be found that all these structures are affected simultaneously in varying degree. For clinical purposes we may divide vulvitis into the following varieties: i. Traumatic; ii. Catarrhal; iii. Dermal (dermatitis, eczematous, herpetic, pruriginous); iv. Ulcerative; v. Septic; vi. Diphtheritic; and vii. Erysipelatous.

i. **Traumatic vulvitis** resulting from burns, scalds, powerful caustics, or injuries, usually heals spontaneously.

ii. **Catarrhal vulvitis** may be acute or chronic. It is common at all periods of life, and is generally due to some constant source of irritation, or to the introduction of septic material from without; by want of cleanliness, contact of dirty fingers as in scratching, coitus, masturbation, gynæcological manipulations, dirty sponges, soiled linen, septic vaginal discharges such as putrid lochia and menstrual flow, and those resulting from neglected tampons, sloughing cancer or myoma; or by contact with ammoniacal or saccharine urine and fæces in cases of vesico-vaginal and recto-vaginal fistula. In infants the causes are want of cleanliness and constant contact with decomposing urine and fæces; in older children, oxyurides wandering into the vagina from the rectum lead to scratching and rubbing; and the wounds thus caused become infected and inflamed. At all ages gonorrhœa is a frequent and important cause, and the epidemics of vulvo-vaginitis which occur in schools are probably attributable to it.

*Purulent vulvitis* is generally gonorrhœal both in children and adults. The importance of gonorrhœa in women was pointed out nearly a quarter of a century ago by Nöggerath, but has only recently received the attention which it deserves. According to Sânger, 12 per cent of all the women who consult a gynæcologist suffer from gonorrhœa, and considerably more than one-third of sterile marriages are due to this disease. Acquired sterility after the birth of one child Sânger believes to be due, as a rule, to gonorrhœa. But there may be purulent vulvitis which is not gonorrhœal; it is met with most frequently in poorly nourished lymphatic children, and in obese women.

*Signs and Symptoms.* — In acute vulvitis there is sharp local pain, increased by movement and micturition; the inflamed structures become red and swollen, and there is a mucous, muco-purulent, or purulent discharge. The glands of Bartholin may be involved, leading to abscess. In gonorrhœal vulvitis the symptoms are especially acute. In chronic vulvitis the signs are less pronounced; there is less swelling and redness, often excoriation with hypertrophied papillæ. The glandular structures about the vulva sometimes participate in the inflammation and form small projections, pustules, or boils; to these the term follicular vulvitis has been applied. The glands of Bartholin may also

be implicated; in which case they are indurated, and exude a little milky or greenish pus. Sir Wm. Priestley described a form of vulvitis under the name of chronic papillary inflammation of the vulva; and Matthews Duncan a somewhat similar condition, of a very obstinate nature, which he considered to be closely allied to lupus. Trachoma pudendorum is a name applied by Tarnowsky to a condition found in prostitutes as a result of gonorrhœa; it is characterised by grayish or yellowish nodules about the size of a pin's head.

*Diagnosis.* — The signs and symptoms are usually clear enough to render the diagnosis of vulvitis easy; but it is often difficult to distinguish one variety from the other. It is especially important, but often impossible to determine whether the inflammation present be of a gonorrhœal nature or not. The history of the case is generally wanting or misleading; but the following features may be looked upon as important: — a purulent discharge in the absence of ulceration, erosion, or malignant disease associated with inflammation of the urethra and glands of Bartholin; a well-defined reddish margin around the urethral orifice, and two bright red spots marking the orifices of the ducts of Bartholin's glands (macula gonorrhœica, considered by Sânger as especially important); warty condylomata complicated with granular vaginitis; salpingo-perimetritis; sudden development of inflammatory disease of the genital organs in a newly married woman, which injures her health to a degree out of all proportion to the local condition; habitual abortion; sterility acquired after the birth of one child; ophthalmia neonatorum, and especially the detection of the gonococcus.

*Prognosis.* — In simple vulvitis, provided the cause can be removed, the prognosis is good. Gonorrhœa in women is always a serious disease, much more so than in men; but Veit believes that the inflammation resulting from a single inoculation will always heal spontaneously, an opinion he has founded upon clinical observations and experiment. He has never met with a case of inflammation of the uterine appendages resulting from a single infection; but repeated inoculations render the prognosis a much more serious matter. In general terms it may be said that so long as the disease has not advanced above the os internum the prognosis is relatively good, but once the tubes and peritoneum become inflamed a cure is very improbable. Even when the disease is limited to the vulva and vagina, especially if it involve the glands of Bartholin, it may run a chronic course; it often remains latent for years, and suddenly recurs without fresh infection. An ingenious theory to account for this phenomenon has been suggested by Luther of Magdeburg. It is well known that the disease usually spreads by the gonococci invading and destroying the cells, and the microbes thus set free invade other cells. According to Luther's theory, the gonococci in the course of time become attenuated, and failing to destroy the cells, remain latent in them; but should a tissue thus invaded become subject to traumatic or other injury, the microbes again become virulent and, invading other cells, rekindle the original disease. He thinks variation in virulence would be a better term than latency.

*Treatment.*—The prophylaxis of vulvitis consists in scrupulous cleanliness. In schools and institutions it is of great importance that each person should have her own basin and towel. Sponges should as far as possible be avoided, and certainly they should not be used in common. A man suffering from gonorrhœa should be cautioned as to the dangers likely to follow a marriage contracted before the disease is cured.

In acute vulvitis the patient should be confined to bed; her diet should be of a light, unstimulating character; her bowels should be relieved by a mild aperient, and she should sit from half to one hour in a warm hip bath to which has been added carbonate of soda, permanganate of potash or bran; after this a compress wet with liquor plumbi subacetatis dilutus (Goulard's lotion), solution of boric acid ( $\frac{1}{2}$  to 2 per cent), or salicylic acid (1 in 6000) should be applied and frequently renewed. The compress may be either cold or hot as the patient may prefer. A similar line of treatment is applicable in some chronic cases, but astringent and antiseptic applications will also be required. Solutions containing acetate of lead and opium, tannin, carbolic acid (1 in 40), sulphate of copper (1 per cent), corrosive sublimate (1 in 3000), answer this purpose. In chronic cases, and particularly in the intertrigo of fat women, dusting powders will be found of advantage, as for example: *Acidi borici, Zinci oxidi, āā ʒij.; Pulv. amyli, ʒiv.; Pulv. rad. iridis florentinæ, ʒj.*

Ointments are less popular now than they were formerly; still they are indispensable in some cases, especially where the surface has to be protected from irritating discharges, as in cancer, fistula, and the like. A very valuable ointment in such cases is the oxide of zinc ointment of the Pharmacopœia to which 5 per cent of carbolic acid has been added; or, if there be much local irritation, thymol (2 per cent), or cocaine (10 per cent).

In follicular vulvitis the pustules should be opened, and the parts fomented with an antiseptic compress.

In acute inflammation of Bartholin's glands a warm sublimate compress should be constantly applied; and as soon as the abscess shows any tendency to point, it should be freely opened, well washed out with an antiseptic solution (lysol or creolin), and the cavity packed with moist iodoform gauze. In chronic cases a similar course may be followed; but total extirpation of the gland is the most satisfactory means of cure. In gonorrhœal vulvitis nitrate of silver has a great reputation; but it is probably inferior to some antiseptics already mentioned, and according to Schaeffer it is decomposed and rendered useless by albumin and chloride of sodium; he proposes as a substitute for it argentamin (diamine-silver-phosphate). In the hope of aborting the disease very strong caustic solutions have been recommended by some authorities, but this hope is illusory owing to the anatomical conditions of the parts and the biological peculiarities of the gonococci. A milder and more prolonged course of treatment is more satisfactory; and it must not be forgotten

that vulvitis is frequently associated with vaginitis, the treatment of which should not be overlooked. After bathing or douching, the labia should be kept apart by a tampon soaked in iodine and glycerine. In very chronic cases benefit has resulted from the use of chloride of zinc, ichthyol, and galvanism.

**iii. Dermal Vulvitis.**— Simple dermatitis or intertrigo is generally met with in fat women, and begins in the groove between the labia majora and the thighs. The sweat and sebaceous matter collected in this groove, submitted to heat and moisture, decompose, become exceedingly irritating, and cause inflammation or scalding.

The inflamed parts should be thoroughly cleansed with warm water and some non-irritating soap, or with a soda solution, and then powdered with boric acid or iodoform. Or the following lotion may be dabbed on: Calaminæ prep. ℥ ss., Zinci oxidi, ℥ ij., Glycerini, ℥ j., Aq. rosæ, ad ℥ viij.

*Eczematous Vulvitis.*— Eczema may be acute or chronic, but the latter is more common. In acute eczema the patient experiences a burning sensation in the labia majora; this is followed by redness, swelling, and the eruption of little vesicles about as large as a pin's head. These are often overlooked, and are best seen by a side light. When they burst they leave a moist, excoriated surface which rapidly becomes covered with crusts. The eruption is attended with a certain amount of fever and gastric disturbance.

The chronic form generally appears as eczema rubrum; it is seldom limited to the labia majora, but rapidly involves the neighbouring skin and the mucous membrane of the vagina. It frequently occurs in gouty and lymphatic patients, and in association with diabetes. The prognosis is usually good, but in some cases the disease is exceedingly chronic.

In the acute stage cold or warm compresses and subacetate of lead lotion are generally all that is needed. Where crusts have formed oily applications are necessary, and are generally used in the form of ointments.

When the discharge is profuse and watery the surface should be powdered. In more chronic cases Hebra's unguentum diachylum, white precipitate ointment, or—℞ Acidi borici ℥ j., Plumbi acet. gr. x., Bismuthi subnitr. ℥ ij., Vaselini ad ℥ j.; M. ft.; Ung. Or again—Pulv. amyli, Bismuthi carb. āā ℥ j., Cremoris alb. ad ℥ j.; M. ft.; Ung. In very chronic cases sapoviridis and tarry preparations may be used; the last-mentioned, however, with caution.

*Herpes vulvæ* is characterised by the appearance of little vesicles in groups. It occurs most frequently in fat women at the commencement of menstruation; pregnancy also disposes to it. The eruption is generally preceded by a burning sensation, the vesicles disappearing in from seven to eight days. These two affections are very liable to be confounded with one another: eczema, however, has a tendency to spread at the edges; herpes appears in successive crops. In eczema, too, the skin is more or less involved and swollen; this is not the case in herpes.



Great care must be taken, however, not to confound either with syphilitic eruptions.

*Prurigo*. — This affection, which causes very distressing itching, is characterised by the appearance of a papular eruption. The little papules are of the same colour as the skin, and, according to Klebs, are due to dilatation of the lymphatics in the hypertrophied papillæ, causing irritation of the terminal filaments of the nerves of the skin.

The diagnosis is more easily made by the touch than by sight, — a rough, goose-skin sensation is conveyed to the examining finger. The disease, which is of a very obstinate and intractable nature, is happily rare in these countries.

The following formulæ are useful: — ℞ Menthol, ʒ ij., Ol. olivæ ʒ iv., Chlorof. ʒ j., Lanolini ʒ ij.; M. ft.; Ung. A cone of ol. theobromæ impregnated with cocaine, 2 per cent (Porritt). ℞ Ac. salicyl. ʒ ss., Creasoti ℥ xl., Glycerini amyli ʒ iij., Lanolini, ʒ j.; M. ft.; Ung.

iv. **Ulcerative vulvitis**, or aphthous vulvitis, occurs in young children from two to five years of age, generally after the exanthemata. Little circumscribed spots appear upon the mucous membrane, sometimes ulcerate, and occasionally become gangrenous. This affection has been confounded with noma pudendi; but in this latter disease gangrene is an essential characteristic, not an accidental sequela. The child's general health should be attended to, and the spots dusted with some mild antiseptic powder.

v. **Septic vulvitis** is most frequently met with in child-bed in the form of a puerperal ulcer; the symptoms which accompany this ulcer are fever and smarting on passing water. One labium is usually œdematous, and when examined upon the inner surface, a fissure or ulcer can be discovered having a white base, a red and inflamed margin, and a thin, irritating discharge which excoriates the surface of the skin over which it flows. Formerly these ulcers were treated very actively, and cauterised with strong acids or the actual cautery; but such violent measures are unnecessary: healing usually goes on rapidly when the affected part is kept clean and powdered with iodoform. If the poison be of a more virulent nature gangrene may extend more widely, and leave deep ulcers which, if the patient recover, may lead to stenosis of the vulva.

*Noma pudendi* is a name applied to gangrene of the vulva occurring in young children, especially after the exanthemata, and resembling noma of the face which occurs under similar circumstances. This disease is due to septic inflammation. It commences with burning local pain and fever; the tissues swell, becoming dusky red, brown, gray, or black; bullæ form upon the surface and burst, discharging a thin, ichorous serum, and a dark slough is exposed. The disease is generally fatal; but should the patient recover, there will be marked deformity from cicatricial contraction.

The treatment must be general as well as local. Alcohol should be given in large quantities, together with easily assimilable nourish-

ment. Locally the diseased tissues are to be destroyed with the actual cautery or fuming nitric acid; the former is preferable. Some prefer excision with careful disinfection of the raw surfaces, the wound being closed by suture.

vi. Diphtheritic and dysenteric vulvitis are complications of the two diseases respectively concerned.

vii. *Erysipelas vulvæ* occurs in young and neglected children. In adults it assumes a more chronic form, and has a tendency to recur at each menstrual period, disappearing in the intervals. There is redness of the skin attended by a burning sensation, pain in the parts, and fever. The disease often remains latent during the intervals between the attacks, and its recurrence is due to an alteration in the nutrition of the parts at the menstrual periods.

The treatment consists in dusting with powders containing boric or salicylic acid, painting with nitrate of silver, the application of compresses of carbolic acid or corrosive sublimate. Hypodermic injection of a two per cent solution of carbolic acid, first recommended by Huter, has been used with benefit. Benefit has also been derived from rubbing turpentine into the skin.

viii. *Pruritus vulvæ* is the term applied to a chronic and very distressing condition which results from a variety of causes. It is doubtful whether the affection is ever the result of a pure neurosis, though it is often impossible to determine its exact pathological nature. Diabetes is frequently a cause of pruritis, and it is sometimes due to vegetable parasites, such as the *leptothrix vaginalis* or the *oidium albicans*. In some cases of chronic vulvitis pathological changes occur in the papillæ of the skin; especially in the fossa navicularis, on the hymen, and in the neighbourhood of the urethral orifice. The altered condition of the papillæ persists and is a constant source of irritation.

There are cases, however, in which no pathological cause is discoverable, and which, in the present state of our knowledge, must be regarded as primary neuroses. This primary pruritis is most frequently found in women about the menopause; very rarely in young women. The chief symptoms are itching and burning in and about the labia, especially in the clitoris and its immediate neighbourhood; but sometimes it spreads over the mons veneris, thighs, and anal region. The itchiness is seldom constant, but mostly occurs in paroxysms. It is aggravated by warmth or motion, and is most marked at night. It attains its greatest intensity during sexual intercourse. So intolerable does this itchiness become at times that women affected with it can hardly refrain from scratching even in public, and occasionally their condition becomes such a miserable one that in order to escape from it some have committed suicide.

The first and most important step in treatment is to try to discover the cause. But even where no cause is discoverable local treatment may give relief. Bathing with carbolic lotion, corrosive sublimate ( $\frac{1}{1000}$ ), boric acid lotion, or lotion of subacetate of lead, has been found useful. Painting with a strong solution of carbolic acid, or

nitrate of silver, or with tincture of iodine; or powdering the parts with iodoform and tannic acid, have been known to give relief. Scanzoni recommended painting with chloroform liniment—two parts of chloroform to sixty of oleum amygdalæ. Equal parts of powdered alum and sugar mixed and dusted over the parts is another method of treatment. Baths do good. All rubbing and scratching should, as far as possible, be avoided. Relief from the itching may be given by the application of an ointment of cocaine. Internally bromide of potassium, and occasionally sulphonal and morphia, have been of service. In some cases arsenic has done good. In a few cases, where the itchiness was limited to portions of the mucous membrane, benefit has followed extirpation. Fehling removed both labia majora and the clitoris in an obstinate case of pruritis with permanent benefit. A weak galvanic current deserves a trial, the anode being placed on the vulvæ, and the kathode applied to the various affected parts; good results from this method of treatment have been recorded. The general health should be attended to.

**VENEREAL DISEASES.**—Soft chancre generally appears shortly after infection, usually within twenty-four hours. It is a small vesicle or pustule, often overlooked, which leaves a rapidly spreading ulcer with a yellowish base, bright red, sharply defined, or undermined edge, and a thick purulent discharge. Soft chancre may be single, but it is generally multiple. With appropriate treatment it heals in a few days; though in tuberculous and alcoholic patients it has a tendency to slough or to assume a phagedænic form. The microscope reveals enlarged vessels and hypertrophied papillæ in the neighbourhood of the ulcer, whilst those on the surface are undergoing a process of necrosis. These chancres may occur in any part of the vulva. One inguinal gland is usually inflamed and generally suppurates.

Syphilis manifests itself in a hard chancre and the eruptions of secondary and tertiary syphilis. The hard chancre usually appears after a period of incubation of about one month from the time of infection as a little indolent red spot, the base of which becomes indurated, feeling like cartilage. It rarely assumes a papular form, but more frequently that of an ulcer. As a rule the surface of the chancre is on a level with that of the neighbouring tissue. It is usually single, but occasionally multiple.

Secondary syphilis occurs as superficial erosions, from the size of a millet seed to that of a sixpence (*plaques muqueuses*), and papular syphilides. Tertiary syphilis occurs in the form of gummata. These tumours appear at first as nodules which soften and ulcerate.

For the constitutional treatment of syphilis I must refer the reader to works on that subject. Locally these affections may be dusted with antiseptic powder, or cauterised with nitrate of silver.

**TUMOURS OF THE VULVA.**—**Inguinal hernia**, though less common in women than femoral, is not very rare. The bowel may descend into the

greater labium through the canal of Nuck, when it is called *hernia labii majoris anterioris*, in contradistinction to the second form, which descends through the pelvic diaphragm and is termed *hernia labii majoris posterioris*.



FIG. 117. — Descent of perineal hernia in front of the broad ligament.

This latter form is exceedingly rare. It may occur in two ways:— Firstly, the hernia may descend in front of the ligamentum latum, distending the vesico-uterine fold of peritoneum, and passing down between the bladder and uterus along the vagina into the labium (vagino-labial hernia); or it may descend behind the ligamentum latum between the rectum and



vagina either into the labium or into the perineum. The hernia may contain the uterus and ovaries as well as intestine and omentum. The diagnosis is of great importance, posterior labial hernia being especially liable to be mistaken for cysts of Bartholin's glands. The annexed photograph, taken from a patient in the Rotunda Hospital, shows a large perineal hernia which had descended in front of the broad ligament. About half the contents could be reduced into the abdominal cavity, and as they again descended into the sac could be felt through the vaginal wall.

**Varicocele** is a very common result of pregnancy, tumours, and constipation. This condition seldom gives rise to much disturbance. The patient complains of a feeling of weight and distension often attended by itching. The chief danger is rupture of a vein, cases of fatal result having been recorded as following this accident.

Compression of the veins, so useful in varicose condition of the lower extremities, is difficult to carry out in this situation. A T bandage and compress is so inconvenient that it can only be adopted in the worst cases. We are obliged to restrict our measures to rest in bed and the use of astringent washes. In case of rupture hæmorrhage should be controlled at once by the application of a compress and, as soon as the necessary preparations can be carried out, by ligature.

**Hæmatoma, or thrombus vulvæ**, generally occurs during labour from the rupture of varicose veins, blows, or wounds. An elastic globular tumour of a deep purple colour forms in the labium which is neither hot nor tender. This is accompanied by a feeling of tension and a desire to urinate. The tumour may burst, or there may be internal hæmorrhage without rupture of the tumour. In either case the patient frequently bleeds to death. Should she survive, putrefaction of the effused blood may occur with symptoms of sapræmic infection or acute pyæmia.

In small effusions an ice-bag may be applied; but in more severe cases it is better to lay open the cyst by a free incision and control the hæmorrhage by suture, or by firmly packing the cavity with gauze. Should symptoms of putrefaction or suppuration occur the cyst should be thoroughly evacuated, disinfected, and treated in a similar manner.

**Warty condylomata** are generally the result of venereal infection, but may occur independently of this cause, especially in infants and pregnant women. They usually commence in the folds between the labia majora and minora. They sometimes occur singly, but are often agglomerated so as to form very large tumours. There is hypertrophy of the papillary layer of the skin. They may spread over the hymen, the perineum, and around the urethra and anus. The symptoms are not very pronounced, and are chiefly due to the irritating discharge. Large tumours cause a feeling of weight; but as a rule patients only complain of burning and smarting. These growths may be dusted with an astringent antiseptic powder, but the most satisfactory method is their total removal with scissors or knife.

**Elephantiasis** is a disease seldom met with in these countries. It is characterised by a local hyperplasia of the skin, and by an increase of subcutaneous connective tissue. The surface is sometimes smooth and shining — elephantiasis glabra; sometimes warty — elephantiasis verrucosa; sometimes covered with projections — elephantiasis papillomatosa: sometimes the swelling feels hard, at other times soft. The lymphatics are enlarged, and there is a small-celled infiltration around the blood-vessels, especially round the veins, with an increase of connective tissue. It is not certain whether the lymphatic dilatation is a primary or secondary affection.

*Etiology.* — Very little is known of the causation of this disease, but the fact that it is endemic in certain countries points to infection. It usually begins between the ages of 15 and 40, but has been known to begin in infancy. Various causes have been assigned, such as syphilis, soft chancre, scrofula, masturbation, and various inflammations, especially erysipelas. None of them, however, occurs with sufficient constancy to be accepted as an undoubted cause.

*Symptoms.* — In hot climates the disease often commences as an acute affection, but not so with us. The hypertrophy is attended by itching, smarting, and some discharge; but the patients chiefly complain of a feeling of weight due to the size of the tumour, which also causes difficulty in walking, cohabitation, micturition, and defæcation.

*Diagnosis.* — This disease is liable to be confounded with other hypertrophic skin diseases associated with ulceration, especially with lupus and cancer. In both these affections the ulceration is more extensive, and in the latter case it runs a much more rapid course.

*Treatment.* — Elephantiasis is essentially a chronic disease, and, excepting from some complication, does not endanger life. It does not, however, yield to treatment; and strapping, which Hebra found so beneficial when the disease involved the lower extremities, can seldom be employed where it attacks the vulva. The only treatment likely to give relief is total removal. This is best accomplished by the procedure introduced by Schroeder, namely, to begin at the posterior limit of the disease and remove it bit by bit, closing each portion of the bleeding wound by suture.

**Lupus.** — If we limit the name lupus to disease undoubtedly tubercular, then lupus of the vulva is almost wholly unknown. In one case only were tubercle bacilli demonstrated, namely, by Viatte in 1891. In another case giant cells and caseous degeneration were observed by Birch-Hirschfeld; but in the great majority of cases commonly called lupus no tubercular disease is demonstrable. Such cases are characterised by infiltration of the mucous membrane, which soon ulcerates, and the ulceration spreads superficially, often healing in one place while it extends in another. The disease usually commences in the labia minora, spreading gradually to the clitoris and vagina. The ulcers are often excavated with jagged edges. The base is sometimes red, sometimes yellowish, and covered with small nodules or polypoid outgrowths. The vesico-vaginal and recto-vaginal

walls are often the seat of infiltration leading to ulceration, which frequently causes fistula.

*Symptoms.*—At first the symptoms are not well marked. When ulceration occurs there are irregular hæmorrhages and leucorrhœa, but rarely pain. The progress is slow ulceration, healing in one direction, whilst it extends in another.

*Diagnosis.*—Syphilis is distinguished by the general symptoms and history, and, in doubtful cases, by a course of special treatment. Cancer is distinguished by its more rapid growth, its general appearance, glandular implications, and deeper ulceration. In elephantiasis hypertrophy rather than ulceration is the chief feature, and it most frequently involves the labia majora; whereas lupus is characterised more by ulceration than hypertrophy, and the lesser labium is primarily affected.

*Treatment.*—The only successful treatment consists in the removal of the disease either by the knife, by curettage, or by the actual or potential cautery; but where the disease involves the vesico-vaginal or recto-vaginal septum the greatest possible care must be taken not to open either the bladder or the rectum, as the diseased structures will not readily unite; indeed, it would probably be found impossible to repair such an injury.

**Malignant disease** occurs in the form of epithelioma, medullary cancer, scirrhus, and sarcoma. Primary cancer of the vulva is comparatively rare; but of the forms mentioned epithelioma is much the most frequent. It begins generally in the larger labium, or in the cleft between the labia majora and minora, where the cutaneous and mucous structures become continuous. It first appears in the form of little nodules in the skin which become warty, shed their epithelium, and discharge a watery fluid tinged with blood. An ulcer forms which spreads superficially at first, but later extends more deeply, and involves the neighbouring structures. The inguinal glands in the early stage of the disease become sympathetically enlarged; subsequently the enlargement is due to infiltration. At first the disease is confined to one side, but the opposite labium becomes involved in many cases, probably through inoculation.

*Symptoms.*—The earliest symptom is pruritus, more particularly when the clitoris is involved. The ulceration and discharge cause discomfort; but pain is seldom complained of until the disease is far advanced. Hæmorrhage is a late symptom and one that rarely proves fatal. Death occurs in the majority of cases from marasmus attributable to chronic septic infection, and metastasis.

*Prognosis.*—The prognosis is bad; however, a few permanent cures after operation have been recorded.

*Treatment.*—Total removal of the disease is the only method of treatment which holds out a prospect of cure. Birschhoff has recorded good results from the galvano-cautery. Most operators prefer the knife; but if cancer be inoculable, then the destruction of the disease with the

actual cauterly affords a better prospect of radical cure than any cutting operation.

In cases where operation is undesirable, the putrid and irritating discharge can be controlled for a time by scraping and the cauterly. Where the disease is too far advanced for this treatment, the ulcers may be sprinkled with equal parts of iodoform and charcoal, and dressed with absorbent gauze.

**Fibroids** occur most frequently in the larger labia, but are sometimes found upon the perineum and the nymphæ. These tumours are encapsuled, and consist of muscular and connective tissue; sometimes they attain large dimensions and become pedunculated. Although these tumours are not in themselves dangerous to life, yet sometimes the inconvenience due to their weight and position render their removal advisable.

**Lipoma.** — The favourite site of these tumours is the neighbourhood of the mons veneris and larger labia. In appearance they resemble elephantiasis, but on extirpation they are found to consist of fatty tissue.

**Enchondroma.** — Enchondroma of the clitoris. One case has been recorded by Schneevogt. Ossification of the clitoris mentioned by Beidel is probably of this nature.

**Neuroma.** — Simpson has described one case and Kennedy another.

**Angioma.** — This variety of tumour is exceedingly rare.

**Cysts.** — Apart from the cysts of Bartholin's glands, other cysts occur in the labia and neighbouring region; however, they are comparatively rare, and are due to obstructed glands, hæmorrhage, or dilated lymphatics.

**Kraurosis Vulvæ.** — Our knowledge of this affection is due to the late Professor Breisky of Prague, Dr. Martin of Berlin, and his assistant Dr. Orthman. It is characterised by a peculiar atrophic shrinking of the integuments of the external genitals and perineum, resulting in obliteration of the normal folds.

The tissues affected become dry, shrink, lose their normal elasticity, and become so brittle that the most careful examination may cause deep fissures. The surface assumes a whitish macerated shining appearance.

The microscopic examination reveals atrophy of the corium, especially of its upper layer. The papillæ are ill-developed, and the rete layer so thin that the epidermis lies directly upon the papillæ. The sebaceous glands are absent, and only a few remnants of sweat glands remain. There is found a small celled infiltration of the papillæ in the deeper layer of the corium. At the margin of the disease Orthman found the tissues hypertrophied, a small celled infiltration of the corium, and a flattening out of the papillæ.

**Symptoms.** — In some cases symptoms are slight or absent; but generally there is a most unpleasant itching and burning sensation, especially during micturition, and occasionally an irritating discharge. Owing to the narrowing of the vulva, and the tenderness, rigidity, and brittleness



of the tissues, the disease may render coitus excessively painful or impossible. The cause of this condition is unknown.

*Treatment.* — This disease does not yield to any remedy, but removal of the tissues involved has been followed by complete relief without any subsequent recurrence.

**VAGINITIS, COLPITIS, OR ELYTRITIS. — The Normal Vaginal Discharge.** — In its healthy state the vagina contains a discharge, to the character and nature of which Döderlein has given special attention. He restricts the term normal to a discharge having the following main features: — It is a whitish gray material, of the consistency of clotted milk, of intensely acid reaction, and containing an almost pure culture of the vaginal bacillus; of other micro-organisms, the odium albicans and the yeast fungus can occasionally be detected. Saprophytes are rapidly destroyed in this material, probably owing to its acidity. It never yields pathological germs by culture; and its injection into animals is followed by equally negative results. In describing this discharge I have purposely avoided the term secretion, for, in connection with a membrane practically destitute of glands, it seems to me incorrect to adopt that term; it is more proper to consider it as an exudation from the general vaginal surface. Be this as it may, its exact source remains a question of uncertainty. It has been asserted by some authors that it comes from the cervix and from the vulvo-vaginal glands; but the absence of mucus from its component elements negatives such a hypothesis.

The pathological discharge, which is an important symptom of vaginitis, but is found independently of that affection, is of a yellow or greenish yellow colour, of creamy consistency, sometimes frothy, or mixed with viscid mucus, feebly acid or even alkaline in reaction, and contains various micro-organisms. The essential distinction between the normal and the abnormal discharge is, that whereas saprophytes perish rapidly in the former material, the latter constitutes an environment peculiarly favourable to their growth. It is, therefore, evident that the vaginal discharge must be modified before it can become a soil suitable to the life and development of saprophytes and other germs. Such a modification is effected by the copious alkaline efflux which descends from the uterine cavity during menstruation, child-bed, uterine catarrh, and cancer; or from the cervix when that part is in a state of catarrhal inflammation. In the diseases last mentioned the germs for the most part reach the seat of pathological change through the vagina; but so long as the vaginal discharge is normal that structure maintains its integrity. Sexual intercourse often conveys noxious matter into the vagina — saprophytes, tubercle bacilli, and other germs; but, contrary to what might have been expected, even in gonorrhœa the vagina is seldom primarily affected, but becomes so secondarily from the uterus, the vulva, or the urethra. No doubt the anatomical structure of the membrane helps to preserve it from invasion; which is much more

likely to occur when it is altered by constant contact with copious irritating discharges such as flow from the uterus in cancer, sloughing myoma, and septic puerperal affections, or by irritating alkaline urine and fæces in urinary and fæcal fistulæ. Similarly foul, ill-fitting, or neglected pessaries — especially those made of soft rubber or wood — neglected tampons and other foreign substances, the actual or potential cautery, vaginal douches when used too hot or with foul vaginal tubes, gynæcological manipulation with septic hands and instruments, not only remove or destroy the normal vaginal discharge, but macerate and irritate the mucous covering, and lead to exfoliation of the epithelium and other anatomical changes which render the part liable to the invasion of disease. Certain constitutional diseases, such as tuberculosis, dispose to leucorrhœa; and the exanthemata, as well as erysipelas, diphtheria, and dysentery, must be included amongst the causes of vaginitis.

**Simple Catarrh.** — In this disease, when acute, the mucous membrane is uniformly swollen, and of a bright red colour; the rugæ are exaggerated; there is a small celled infiltration of the epithelial structures, and a shedding of epithelial cells. The discharge is feebly acid or alkaline. It contains leucocytes and other micro-organisms, besides desquamated epithelium. When chronic it appears to have a selective affinity for the anterior vaginal wall, and the signs and symptoms are less marked. Granular vaginitis is often gonorrhœal, and is most marked in pregnant women. The papillæ are hypertrophied, infiltrated with small cells, and fused together so as to form the so-called granulations, the epithelial covering of which is shed so that they assume a dark red colour.

**Gonorrhœal Vaginitis.** — The mucous membrane is red, hot, and swollen; the discharge, which is profuse, is at first creamy, but becomes purulent with the progress of the disease. The papillæ are evident to the sight and touch. Gonococci are found in the discharge, and in the epithelial cells and leucocytes. In the chronic form the disease is generally confined to the fornices and vulvo-vaginal glands.

**Vaginitis vetularum vel adhesiva** is, as its name implies, peculiar to women who have passed the menopause. The membrane is smooth, reddish, and atrophied in patches which are denuded of epithelium. These denuded surfaces are due to defective nutrition rather than to the action of micro-organisms; and they tend to grow together, forming firm adhesions. In some cases the fornices become entirely obliterated by their surfaces growing together, or by their adhesion to the cervix; in other cases the adhesion occurs so low in the vagina that the cervix can be neither felt nor seen. When recent the adhesions may be broken down and the natural shape of the vagina restored; but, as a rule, this will be found impossible. This form of vaginitis is so common that few women over sixty years of age will be found without some adhesions.

**Symptoms of Vaginal Catarrh.** — In the acute form the patient complains of hot and burning feelings, accompanied with a bearing-down sensation with increased secretion, at first serous, then mucous, muco-

purulent, and often purulent. The vulva is generally involved, and sometimes the urethra, in which case the patient complains of frequent and painful micturition. In chronic vaginitis the profuse discharge is what the patients chiefly complain of. In adhesive vaginitis there are no symptoms except occasionally a thin discharge.

*Physical Signs.* — The finger feels the soft and swollen membrane and consequent narrowing of the canal. In the granular form the hypertrophied papillæ feel like granules upon the surface. When the speculum is passed, the membrane is observed to be red and swollen, and the foldings exaggerated. In some cases bright red papillæ protrude above the surface, and a fair estimate can be formed of the amount and character of the discharge. In the senile form the adhesions can be detected by the finger.

*Prognosis.* — Vaginitis may be regarded as a curable disease in every case in which the cause of it is remediable. The prognosis is doubtful in cases of gonorrhœal vaginitis, because the disease in the cervix, in the vulvo-vaginal glands, and in the husband, may not be curable; and it is absolutely bad when the affection is due to persistent irritating discharges, as in incurable fistula and cancer.

*Prophylaxis.* — Amongst prophylactic measures the most important are, firstly, to prohibit marriage to men suffering from gonorrhœa for at least two years from the time of infection; and if Veit's observations be correct, it is almost as important that a woman who has been infected with gonorrhœa should cease to cohabit with her husband until both have been cured. The third point is the importance of asepsis in minor practice; the avoidance of routine douching, and care in the use of pessaries, plugs, specula, and other instruments.

*Local Treatment.* — In treating a patient who has actually acquired vaginitis, the method to be pursued will vary not only with the kind of inflammation, but also with the condition in which it may present itself — whether acute or chronic, a fresh inflammation or one of long standing. The first duty of the practitioner will be to remove the cause of the inflammation provided that it can be discovered. He should remove pessaries and plugs, cure fistulæ, and treat cervical and other diseases which may be the causes of the vaginitis.

In acute vaginitis the vagina may be irrigated with mild antiseptic douches, either hot or cold. The most frequently used are corrosive sublimate (1 in 2000), carbolic acid (2 per cent), creoline or lysol (1 per cent), salicylic acid ( $\frac{1}{2}$  per cent), boric acid (3 per cent); should these be too irritating, lead lotion or permanganate of potash may be substituted. In many cases no antiseptic at all can be tolerated; in these the vagina is irrigated with plain water, gruel, or linseed tea. As acute vaginitis is always accompanied by vulvitis, sitz baths, rest in bed, and other treatment adapted to this condition must be used at the same time.

Subacute or chronic vaginitis is best treated by local applications applied through a speculum, the patient lying upon her back. A cylindrical speculum does very well; but a modification of Sims' speculum,

lined with platinum or made of vulcanite, is better: by means of this instrument the perineum is drawn backwards, and the vagina then filled with the solution. The best applications for this purpose are crude pyroligneous acid of commerce, or solution of sulphate of copper (2 to 5 per cent). In gonorrhœal cases nitrate of silver (5 per cent) is appropriate. In some cases benefit results from painting the surface of the vagina with tincture of iodine, or dusting it with iodoform or other antiseptic powders. In very chronic cases astringents will be found more useful than antiseptics; amongst these may be mentioned dermatol, tannin, or alum and sugar in equal parts. These are best applied in powder. Astringent injections may be employed by the patient herself; amongst the most useful of these are douches containing alum, sulphate of zinc, borax, and oak bark. In other cases we may use pessaries, made of cocoa butter or glycerine and gelatine, containing the antiseptic or astringent application desired. This method is more popular than it otherwise would be, as the patient herself can readily introduce the remedy; but oily substances are bad vehicles for antiseptic remedies. If made with glycerine and gelatine, which is the form I prefer, they require considerable skill in manufacture; or they may either melt between the fingers before they can be introduced into the vagina, or they may not melt at all, and be voided unchanged.

**Colpitis Mycotica.** — Vaginitis is sometimes due to micro-organisms, of a higher order than bacteria, which flourish in the acid vaginal discharge: such are the monilia (oidium) albicans, monilia candida, and leptothrix vaginalis.

This form of vaginitis is found most frequently in pregnant women with gaping vulvæ, torn perineums, and vaginal prolapse. It occurs more often in summer than in winter, and has been attributed to damp dwellings. The parasites are generally conveyed to the patient by the air or by the fingers, especially when the latter are soiled with meal or flour. Similarly a woman whose infant is suffering from thrush may infect herself; or again, the disease may be communicated during coitus, especially if the husband be diabetic.

*Symptoms.* — The patients complain of intense burning, smarting, and itching. In the majority of cases there is little or no discharge; but where discharge is present it is of an irritating, excoriating character. The mucous membrane is bright red, swollen, and covered with little white patches of varying size, but seldom larger than a pin's head, and excessively tender to touch.

*Treatment* must be actively antiseptic. Douches will afford little or no relief; it is better to introduce a speculum and fill it with solution of corrosive sublimate, sulphate of copper, or nitrate of silver, so that as it is slowly withdrawn the parts are bathed with the fluid. By this means a cure is usually effected in a few days.

**Emphysematous vaginitis** occurs as little cysts containing gas. Winckle, who first described the disease, gave to it the name of colpoplasia cystica.



In the vagina of pregnant women, sometimes in child-bed, or even in women who are not pregnant, hemispherical protuberances with a smooth soft surface, which occasionally give to the finger the emphysematous crepitation, are met with in regular groups from time to time, especially on the anterior wall, in the upper third of the vagina, and on the mucous membrane of the portio vaginalis. They stand upon a swollen bright red base, and are often surrounded by a narrow red margin. If one of these little vesicles be punctured it immediately collapses without any escape of fluid, but occasionally with the sound of escaping gas. This condition is classed amongst inflammations because of the attendant swelling and hypersecretion.

**Exfoliative vaginitis** is characterised by periodical exfoliation of the epithelium of the membrane, and is usually associated with dysmenorrhœa. It was first described by Dr. Farre in 1858; it is generally associated with and probably dependent upon hysteria.

**Diphtheritic and dysenteric vaginitis** occur rarely as complications of these diseases. The term diphtheritic is often erroneously applied to a white membrane which forms in the vagina in some cases of puerperal infection; in sloughing cancer and myoma; and in some of the fevers, especially measles, small-pox, and typhus. Erysipelas may also attack the vagina.

**Phlegmonous Peri-Vaginitis.**—Here the peri-vaginal cellular tissue is the chief seat of the disease, and as the vaginal tube is deprived of its nourishment through this tissue, it necroses and is thrown off as a slough. This rare affection was first described by Marconnat, but its etiology is yet obscure. It has been seen to follow the exanthemata and venereal affections.

*Symptoms.*—Fever, slight hæmorrhages, or putrid discharge. Pain is always present, and was in one case very severe. The labia are swollen and superficially ulcerated. The vaginal mucous membrane is swollen and pale, discoloured and necrosed. Most reported cases recovered, and were not followed by as much contraction as might have been expected.

The *treatment* is limited, in the early stage, to disinfection; in the later to the prevention of contraction of the cicatrices. There is a much more chronic form of peri-vaginitis, associated with chronic syphilis, which sometimes leads to fistulous communications between the vagina and rectum.

**Vaginismus** is a term applied to an abnormal hyperæsthesia of the external genital organs, causing muscular spasm. It occurs chiefly in young, nervous, and hysterical women. It is sometimes associated with irritable urethra, or with a rigid hymen which has become irritated and inflamed. If the hymen is already ruptured the carunculæ myrtiformes are excessively sensitive. This condition has been attributed to fissure of the anus; and to incomplete coitus, resulting from imperfect erection and premature ejaculation. Sometimes the symptoms are due to spasm

of the perineal and levator ani muscles on attempted copulation. At other times there is a feeling of weight in the perineum; hypochondriacal symptoms are also present as a rule. A form of vaginismus, attended with spasm of the levator ani muscles, has been described as superior vaginismus; it causes the very unpleasant complication of penis captivus.

*Treatment.* — Where a local cause is discoverable efforts should be made to remove it; hydropathy, potassium bromide, cocaine, opium, and belladonna in suppository, have been found of benefit in removing the spasm: excision of the carunculæ myrtiformes and gradual dilatation of the vulva may be practised; or the patient may be placed under an anæsthetic and the vulva forcibly dilated with the fingers. Marion Sims used to treat these cases by a V-shaped incision of the posterior wall of the vagina, and I have certainly seen benefit follow this procedure or some modification of it. Electricity has also been tried with some apparent benefit.

**TUMOURS OF THE VAGINA.** — Tumours of the vagina are of the following kinds — cystoma, fibromyoma, carcinoma, sarcoma, tuberculosis.

**Simple cysts** occur in the majority of cases as small tumours, from the size of a cherry stone to that of a walnut; they are seldom so large as the fist or fœtal head. Their position is as variable as their size. They are generally found in the lower half of the vagina, but may occur in any part. The origin of these cysts is not clear: in some cases they originate in a remnant of Müller's ducts; in other cases they may be connected with the Wolffian or Gärtner's ducts. They may arise as retention cysts connected with certain glands discovered by v. Preuschen. Others must be regarded as dilated lymphatics, or extravasations of blood.

Cysts, excepting in cystic vaginitis, are generally single; but sometimes they are multiple. They are covered by ordinary mucous membrane, which may be so thinned by expansion that the contents shine through; they contain mucus either clear or milky from admixture of epithelium, or black or dark from admixture with blood; in multilocular cysts the contents are often various.

*Treatment.* — Small cysts should be extirpated; larger ones should have their surface removed to the level of the vagina, and the cyst wall stitched to the vaginal mucous membrane.

**Fibroids.** — In comparison with uterine myoma these tumours are rare. They most frequently occur in the anterior wall; at first they are broad-based and sessile, but later become pedunculated. They vary in size from a pea to that of a fœtal head or more.

*Symptoms.* — Small tumours cause no symptoms; larger ones cause inconvenience through their weight and pressure on surrounding structures: they may cause a feeling of dragging, difficulty in walking and sitting, irritability of the bladder or difficulty in emptying it. Obstruction arises to coitus and to child-birth.

*Treatment* consists in operative removal. Polypi are removed by cutting through the pedicle with scissors or ecraseur. Sessile tumours should be enucleated. The cavity left may be closed by suture after all bleeding vessels have been ligatured; or, if this be impracticable, it should be plugged with iodoform gauze.

**Carcinoma.** — Primary cancer of the vagina is rare; secondary cancer is very common. The former occurs as a papillomatous growth upon a broad, infiltrated base upon the posterior wall, or as a firm, annular constriction or uniform infiltration of the entire vaginal tube.

*The etiology* is unknown, but it usually occurs between the ages of 30 and 60. Child-bearing has not any influence in its causation.

*The symptoms* are the same as those attending cancer elsewhere. The patients complain of pain; watery discharge often offensive and irritating; hæmorrhage, especially after coitus; and, later, implication of glands and the cancerous cachexia.

*The prognosis* is bad. Patients rarely seek advice until too late for successful extirpation; and even when removal of the growth has been effected, return is almost certain. Probably the best method of operation in these cases is to incise the perineum transversely, to separate the vagina from the rectum from below, to a point above the upper margin of the disease, to excise the detached vaginal wall, and, finally, to close the wound by suture. In cases too far advanced for extirpation, the disease should be scraped away as far as possible with a sharp spoon and cauterised with the actual cautery. Great care must be taken not to injure the bladder or rectum, as a fistula could scarcely be closed again. In many cases our treatment is limited to antiseptic douching or dry dressing.

**Sarcoma** is even rarer than primary cancer, and is remarkable for its occurrence in early childhood; it has even been supposed to be congenital. It may, however, occur at any age. It generally attacks the anterior wall in children, though in adults it occurs as often on the posterior wall. It occurs as a circumscribed tumor, a fibrosarcoma, or as a diffuse infiltration. The disease rapidly spreads to the bladder, rectum, perineum, and external genitals.

*Pathology.* — Microscopically both round and spindle cells occur with an increase of connective tissue. The disease usually originates in the papillæ of the vaginal mucous membrane.

The *symptoms* are irregular hæmorrhages; mucous discharge, often putrid; pain; disturbance of the bladder; a sense of bearing down and wasting.

For *diagnosis* a piece of the diseased structure should be excised and examined with the microscope.

The *prognosis* is exceedingly bad; the disease returns in spite of operation. Schuchhardt gives one case in which the patient remained free from its return for two years.

The *treatment* consists in the earliest possible removal of the disease.

**Foreign Bodies in the Vagina.** — A great number of foreign bodies

have been found in the vagina—glasses, cups, candles, reels, and the like, which have been introduced for sexual gratification; also hair-pins, sponges, tampons, and pessaries which have been worn by patients for ten years and upwards, and have been completely forgotten. Entozoa may be introduced from the bowel; the *ascaris lumbricoides*, the *oxyuris vermicularis*, and the *pulex irritans* have been found, and in one case a grasshopper. Large foreign bodies compel the patients at once to seek medical aid; smaller ones remain to produce vaginitis with purulent offensive discharge mixed with blood, saprophytes, and other pathological micro-organisms, which cause a fœtid irritating discharge resembling that of cancer. Not infrequently stenosis occurs in the vagina, just below the foreign body, with almost complete occlusion of the vagina; the diagnosis can then be made by rectal examination only. The removal of the body is not always a simple matter; but it is an absolute necessity, since its retention might cause death from putrid peritonitis. The first step is the antiseptic douche; the second is to dilate the stricture; the third is to remove the foreign body. Occasionally it is necessary to divide the recto-vaginal septum, which, after the removal of the foreign body, should be followed by immediate reunion. The cavity left should be thoroughly disinfected and plugged with gauze.

W. SMYLY.

#### REFERENCES

- Diseases of the External Genital Organs—Vulvitis:—1. J. M. DUNCAN. *Lancet*, 1877. March 3.—2. *Med. Times and Gaz.* Feb. 3, 1880, p. 199.—3. C. v. BRAUN. *Wien. med. Wochens.* 1878.—4. KINDER WOOD. *Med.-Chir. Trans.* vol. vii.—5. PARROT. *Rev. de méd.* p. 177, 1881.—6. HERMAN. *Obstet. Trans.* 1883.—7. PRIESTLEY. *Obstet. Trans.* 1884.—8. TARNOWSKY. *Ctbl. f. Chir.* p. 354, 1887.—9. E. LUTHER. *Vol. klin. Vort.* N. F. 82, 83, 1893.—10. WERTHEIM. *Verh. der Dtsch. Ges. f. Gyn.* § 346, 1891.—11. SÄNGER. *Verh. d. Dtsch. Ges. f. Gyn.* § 361, 1892.—12. SCHÄFFER. *Verh. d. Schles. Ges. f. Vaterlandkult.* Feb. 1894.—13. J. VEIT. *Zeit. f. Gebh. u. Gyn.* Bd. xxviii. 1894.—14. G. KLEIN. *Monats. f. Geb. u. Gyn.* Jan. 1895. Tumours:—(Elephantiasis): 15. M'CLINTOCK. *Dub. Journ.* xxiii. 1862.—16. PLAYFAIR. *Trans. Obstet. Soc.* xix. p. 184.—17. PETERS and KLEBS. *Prag. Viertelj.*, 124, § 69, 1874. (Lupus): 18 WEST. *Dis. of Wom.* p. 822, 1870.—19. J. M. DUNCAN. *Edin. Med. Journ.* Dec. 1862.—20. HÜTER. *Dtsch. Zeitsch. f. Chir.* iv. p. 508, 1874.—21. THOMPSON. *Lancet*, 1892.—22. HEGAR. *Gen. tuberculosa des Weibes*, 1887. (Malignant): 23. EBERHARDT. *Dis. Würzburg*, 1885.—24. KÜSTNER. *Zeit. f. Gebh. u. Gyn.* vii. § 70, 1881.—25. SCHROEDER. *Zeit. f. Geb. u. Gyn.* iii. 423, 1878.—26. PRESCOTT HEWITT. *Lancet*, March 16, 1861.—27. ROBB. *Johns Hopkins Hosp. Rep.* ii. 227, 1890.—28. THOMAS. *N. Y. Jour.* xxxi. 490, 1880. (Fibromyoma): 29. KLOB. *Path. Anat. d. weibl. Sexualorgane*, p. 459, 1864.—30. M'CLINTOCK. *Dub. Jour.* vol. iv. 1862.—31. A. R. SIMPSON. *Ed. Med. Jour.* 1878.—32. J. M. DUNCAN. *Med. Times and Gaz.* Jan. 24, 1880. (Lipoma): 33. STIEGELE. *Zeit. f. Chir. u. Geb.* Bd. ix. p. 243, 1856.—34. BRUNTZEL. *Ctbl. f. Gyn.* p. 626, 1882. (Enchondroma): 35. SCHNEEVOGT. *Ver. van het Genootschap ter Beoordening d. Geneesen Heelkunde te Amsterdam*, ii. 1, p. 67, 1885.—36. BRIGEL. *Der Krank. des weibl. Gesch.* Bd. ii. p. 728. (Neuroma): 37. SIMPSON. *Med. Times*, Oct. 1859.—38. KENNEDY. *Med. Press. and Cir.* June 7, 1874. (Angioma): 39. SÄNGER. *Ctbl. f. Gyn.* p. 125, 1882. (Cystoma): 40. WERTH. *Ctbl. f. Gyn.* p. 512, 1878.—41. GALABIN. *Obstet. Trans.* p. 54, 1884.—42. *Wiltshire Obstet. Trans.* Lond. 1881. Pruritus Vulvæ:—43. L. MAYER. *Mon. f. Geb.* July 1862.—44. EDIS. *B. M. J. Jan.*



11, 1868.—45. SCHROEDER. *Ctbl. f. Gyn.* p. 805, 1884. Kraurosis Vulvæ:—46. BREISKY. *Zeit. f. Heilk.* vi. 69, 1885.—47. ORTHMANN. *Zeit. f. Geb. u. Gyn.* xix. § 283, 1890. Vaginitis:—48. DODERLEIN. *Das Scheidensekret.* Leipzig, 1892.—49. C. RUGE. *Zeit. f. Gebur. u. Gyn.* Bd. iv. 1879.—50. EPPINGER. *Prag. Zeit. f. Hlk.* iii. 153.—51. E. FRÄNKEL. *Virch. Arch.* xcix. p. 251, 1883.—52. CHIARI. *Prag. Zeit. f. Hlk.* vi. § 81, 1885.—53. BIRCH. *Hirsch. Lehrbuch*, ii. p. 794, 1887.—54. KUMMEL. *Virch. Arch.* cxiv. p. 429, 1888.—55. V. HERFF. *Volk. Sam.* cxxxvii. 1895.—56. WINKEL. *Arch. f. Gyn.* Bd. ii. p. 383, 1871. Vaginismus:—57. J. M. DUNCAN. *Clin. Lect. on Dis. of W.* p. 142, 1883.—58. M. SIMS. *Obstet. Trans.* vol. iii. p. 356. 1862.—59. J. Y. SIMPSON. *Dis. of Wom.* p. 284, 1872.—60. BUDIN. *Progres Med.* Paris, ix. 1887. Vaginal New Growths:—61. O. HEMMING. *Edin. Med. and Surg. Journ.*—62. G. VEIT. *Krankh. des weibl. Gesch.* 1867.—63. WINKEL. *Lehrb. Frauenk.* § 112, 1890.—64. KLEBS. *Path. Anat.* 1876.—65. HALL DAVIS. *Trans. Obstet. Soc.* 1867.—66. v. PREUSCHEN. *Virch. Arch.* Bd. lxx. 1877.—67. CULLINGWORTH. *Obstet. Journ. of Gt. Britain and Ireland*, Oct. 1879.—68. J. M. DUNCAN. *Med. Times and Gaz.* 1880.—69. M'CLINTOCK. *Clin. Memoirs of Dis. of Wom.*—70. PAGET. *Lect. on Surg. Path.*—71. BARNES. *Obstet. Trans.* vol. xiv. p. 309.—72. HEGAR. *Genital-tuberculosis des Weib.* 1887.—73. STRASSMAN. *Ctbl. f. Gyn.* § 825, 1891.—74. BADLY. *Med. and Surg. Reporter*, xlii. p. 199.—75. KLEIN. *Zeit. f. Geb. u. Gyn.* xviii. § 82, 1890. Foreign Bodies:—76. DIEFENBACH. "Fremdkörper in d. weibl. Gen. u. Harnblase," *Dis.* Berlin, 1890.—77. KLEBS. *Handb. d. path. Anat.* Bd. i. p. 976.—78. PEARSE. *Brit. Med. Journ.* 28th June 1873.—79. CARTER. *Obstet. Trans.* p. 34, 1880.

W. S.

## DISPLACEMENTS OF THE UTERUS

EVEN in perfectly normal conditions the uterus is liable to vary greatly in its relations to the pelvic cavity in which it lies. These relations are modified by its own functional activities, as well as by the distension and evacuation of the adjacent viscera. We may consider it as placed in the pelvis: (A) as regards its Level, so that the fundus corresponds more or less to the plane of the brim, and the os externum points to the coccyx in the plane of the ischial spines; (B) as regards its Position, so that it lies nearly midway between the symphysis pubis and sacrum, and between the two sides of the pelvis; and (C) as regards its Direction, so that its axis corresponds more or less to the axis of the pelvis. So we may find it in moderate degrees of distension of the bladder and rectum. Let these organs, however, be fully distended, and the uterus will be raised above the level which we have assigned to it. Let the bladder alone be distended, and the uterus will be carried back beyond the middle line of the pelvis. Let the bladder be emptied, and the uterus will fall forward so that its fundus comes close to the symphysis pubis. It is in this position that it is most frequently found on bimanual examination.

With this wide range of physiological mobility it keeps its place by virtue of: (i.) the insertion of the supravaginal portion of the cervix in the upper end of the vagina, where it rests upon the tip of the sacrum and coccyx in the pelvic floor; (ii.) the action of the utero-sacral ligaments, which keep the isthmus in its proper relation to the upper part of

the hollow of the sacrum; (iii.) the utero-vesicle ligaments, which maintain its relation to the bladder and symphysis pubis; (iv.) the broad ligaments on each side, which especially regulate its lateral movements; and (v.) the round ligaments, which keep the fundus directed upward and forward towards the inguinal canals. When it fails to retain its equilibrium, either in the way of excess of movement beyond its normal range, or of losing the power to recover its normal relations, its displacements become pathological, and give rise to troubles that lead the patient to seek for medical advice.

In a large proportion of cases the displacement will be found to be not simple, but compound. Thus, where there is a downward deviation from the ordinary level, and the uterus is prolapsed, there is usually also a loss of its normal direction, and the uterus is retroverted. But it is the downward displacement that is the most important element in the case, and which most urgently calls for rectification. Again, in many cases an anteflexed uterus may be found lying close to the hollow of the sacrum in a state of retroposition; and it may require careful analysis of the conditions before the practitioner can decide which of the two deviations—the deviation in direction or in position—is the more chargeable with the patient's sufferings. We will study, however, the different displacements in succession and consider:—

#### A. DEVIATIONS FROM THE NORMAL LEVEL

The uterus may be found moved beyond the planes of the pelvis within which it normally ranges either Upwards or Downwards.

I. ASCENT OF THE UTERUS. — In the elevations or upward displacements of the uterus, the organ is lifted off the pelvic floor, and the fundus rises above the pelvic brim so as to be accommodated to a greater or less extent in the abdominal cavity. The gravid uterus, say from the third month onwards, grows gradually and at a steady rate higher and higher in the abdomen. So when the unimpregnated uterus becomes the seat of a large myoma, it may have become largely an abdominal organ before it comes under observation. When a tubal gestation goes on developing beyond the early months; when an ovarian or parovarian tumour grows down into the broad ligament or becomes fixed behind the uterus; when an effusion or extravasation is encapsuled in the pouch of Douglas; or a tumour grows in the rectal wall;— in all these and similar cases the uterus may be lifted or pushed upwards: and even in some peritonitic cases the fundus may have acquired adhesions which drag it towards the abdomen. The ascent of the uterus under such circumstances, however, is only a bye-phenomenon. It may be of vital importance to recognise the abnormal position, and our successful treatment of the patient may depend on its detection; but elevation of the uterus does not present itself to us as an isolated occurrence, and the symptoms associated with it are subsidiary to those of the condition which brought it about. It

is quite otherwise with the downward displacements, which we now proceed to consider.

II. DESCENT OF THE UTERUS. — Prolapsus or procidentia uteri — falling down or protrusion of the womb — are names that have been used to express the downward displacement of the uterus, which leads to its escape from the pelvic cavity till it comes to lie externally to the pudenda. It must be recognised at once that here the dislocation of the uterus is not an isolated phenomenon. As the organ sinks in the pelvis it drags with it its adnexa, the Fallopian tubes and ovaries: its depression is followed by depression of the superincumbent coils of the intestines; and, even if in the early stage of the process the vaginal walls with the bladder and rectum may have retained somewhat of their normal position, in the more advanced stages these have all moved downwards to such an extent that the vagina has become completely inverted: so that we have to do with a hernial process, the pelvic contents escaping through the oblique fissure in the pelvic floor, which we think of as the vaginal canal, until we have a sac, the covering of which is formed by the inverted vaginal walls, and the contents of which consist of the body of the uterus and the adjacent viscera. The displacement may begin at the upper, uterine extremity of the fissure, or at the lower, pudendal extremity; or the favouring conditions may operate simultaneously throughout the whole pelvic floor. But in any case the displacement of the uterus is the central element in the disturbance; its functional troubles are prominent among the attendant symptoms; and the treatment must have regard to its reposition and its retention in its proper place.

The displacement may be met with at different stages, so that a distinction has been drawn between the different degrees of descent.

**Degrees of Descent.** — i. In the simplest cases the uterus has only sunk downwards to a slight degree from its ordinary level, the fundus lying distinctly below the brim of the pelvis, and the os low on the pelvic floor; but it retains its ordinary position in the middle of the pelvis, and the fundus has its ordinary anterior inclination. ii. In a second group of cases, where the prolapse is still incomplete, the uterus has sunk still lower, with the os resting on the anterior margin of the perineum, or appearing at the pudendal fissure, and the fundus is found at a varying height according to the size of the organ. In this variety the uterus has undergone a change in the direction of its axis, and has fallen backwards towards the hollow of the sacrum, so that it is not only in a state of prolapse, but at the same time of retroversion or retroflexion. iii. In cases of complete descent the whole organ has sunk so low that it projects within the inverted vagina completely beyond the pudendal orifice; and in this situation the body is usually found retroverted, though in rare cases the fundus may be directed upwards or forwards. It has sometimes been proposed to distinguish the varying degrees of descent by speaking of the incomplete varieties as cases of prolapsus, and the complete variety as procidentia uteri. The names, however, are not distinctive; and whether we call the descent prolapse or procidence, we

must distinguish between the cases where the uterus is still within the vaginal cavity, and those where it is entirely extruded, by speaking of the former as incomplete and the latter as complete prolapse. In the case of incomplete prolapse, we have the two sub-varieties: (*a*) incomplete prolapse of normally inclined uterus; and (*b*) incomplete prolapse of retroverted uterus. In the case of complete prolapse the direction of the uterus is of minor moment.

**Pathological Anatomy.** — If we look more carefully at the structures protruding through the vulva, we shall find we have to do with different elements of the pelvic contents in different cases. In all the cases the vaginal walls have become dislocated, but as regards other viscera we find in some —

i. *Chiefly displacement of uterus.* — The tumour projecting through the vulva is covered completely with the inverted walls of the vagina, which have lost their rugosities and present a smooth appearance. The os uteri may be seen at the lower anterior part, where the cervix barely projects beyond the general surface of the tumour; and through the walls, the body of the uterus with its adnexa, and occasionally some intestinal coils, can be felt occupying the hernial sac.

ii. *Chiefly displacement of bladder.* — Sometimes the projecting structure is constituted mainly by the descent of the anterior wall of the vagina, carrying with it the back wall of the bladder. The case is one of cystocele. In this condition the uterus may be only in the first stage of incomplete descent, and remain functionally active. If the uterus become gravid the cystocele may become aggravated, and be a source of trouble during pregnancy and labour, whilst the uterine displacement is for the time undone. This prolapse of the anterior vaginal wall, however, is more apt to become associated with hypertrophic changes in the cervix uteri which lead to more complete prolapse of the whole organ.

iii. *Chiefly displacement of rectum.* — In rarer instances it is the back wall of the vagina that projects through the vulva. The case is one of rectocele, so-called, or proctocele.

iv. *Cystocele with hypertrophy of intermediate portion of cervix uteri.* — The circumstance that the vaginal mucosa lays hold of the cervix low down in front at about one-third of an inch from the anterior lip, whilst behind it passes up to within about one-third of an inch from the isthmus, has led to the convenient distinction of the cervix into the three segments. Below we have the vaginal or infravaginal portion, lying entirely free in the vaginal cavity below the level of the anterior fornix; above we have the supravaginal portion embraced by parametrium and lying entirely above the level of the posterior fornix; between these is the intermediate portion lying above the level of the anterior, and below the level of the posterior fornix. On its posterior aspect this intermediate portion lies free in the vagina; its anterior surface lies above the vaginal reflection, and is in contact with the areolar tissue which separates it from the bladder wall. This intermediate portion undergoes a remarkable degree of hypertrophy and elongation in



cases where the anterior wall of the vagina has been displaced. The vesico-vaginal septum that has been exposed through the vulva becomes congested and thickened, and is the seat of a hyperplasia that extends to the portion of the cervix with which it is in intimate vascular relations.

v. *Cystocele and Proctocele, with hypertrophy of the whole supra-vaginal portion.* — In many cases where the cystocele alone exists in a marked degree, the hypertrophy may affect the whole supravaginal portion of the cervix. Such a hypertrophy is more certain to be produced when the posterior as well as the anterior vaginal wall has escaped through the vulva. In such a case the protruded mass has a large segment of the bladder in front and a rectal pouch behind; and is felt to contain only the elongated cervix and isthmus of the uterus, whilst the fundus and its adnexa are still within the pelvic cavity.

**Causes of Prolapsus Uteri.** — We have seen that the uterus maintains its normal level by virtue of a balance between the structures that sustain it and the forces that tend to depress it. We must look, therefore, for the causes of its permanent descent either, on the one hand, to conditions that weaken its supports, or on the other to conditions that increase the strain upon them. These conditions are (a) Passive, and (b) Active. Frequently enough these conditions are simultaneously operative in both directions.

(a) *Passive causes.* — These are to be found in loss of retentive power of the uterine supports, and foremost among the defects that lead to descent of the uterus we must place: —

i. *Faults in the perineum.* — The integrity of the perineum may be seriously impaired, and yet the uterus maintain its normal place. The whole of the structures between the lower third of the vagina and the rectum may be found lacerated to such an extent that the patient is unable to control the action of the bowels, and comes to seek relief because of this trouble. In such a case the uterus may be found at its normal level, the other sustaining structures being of sufficient strength and tonicity to maintain it in place; or inflammatory or cicatricial changes may have impaired its mobility. As a rule, however, damage of the perineum or perineal body is a prime element in the weakening of the pelvic floor that eventuates in herniation of the pelvic contents. This damage is usually inflicted during labour, and may take the form either (a) of laceration beginning at the fourchette, or on the mucous surface, or even on the cutaneous surface, and running more or less deeply through all the tissues to or into the anal and rectal canal; or (β) of diastasis of the muscular and fascial tissues that meet in the perineal body, and lie between the mucous membrane and the skin. In the latter case no cicatrix is to be seen behind the vaginal orifice. The mucous lining and the skin covering of the perineum have been dilated without being fissured, and the structures seem to be entire; but when the perineum is grasped between the finger and thumb, or is stretched on two fingers introduced into the vagina, it is felt to be thin and relaxed, and incapable of offering any effective resistance to the pressure brought to bear on it

from above. Where the perineum has been thus torn or strained, so that it ceases to afford adequate support to the superjacent structures, the first stage of a displacement is seen in the projection of the anterior vaginal wall through the patulous orifice; and where other causes are in operation tending to a descent of the uterus, the displacement comes about the more easily and rapidly from the absence of the resistance offered to it by the healthy perineum.

ii. Faults in the vaginal walls. — We have seen that it is through the vaginal canal that the uterus becomes herniated. It is obvious that the varying condition of the vaginal walls will modify the proclivity to the uterine descent. In the cases where the uterus keeps its place, notwithstanding that the perineum is deeply fissured, the anterior vaginal wall and the posterior wall above the seat of laceration are usually found to be healthy. The rugæ are well preserved; the submucous muscular and areolar tissues have retained their tonicity; and freedom from all the leucorrhœal discharges associated with colpitis allows the walls to retain their normal degree of apposition. Where, on the other hand, the vaginal walls have become so distended as to have lost something of their tonicity, and where, in addition, the surfaces are bathed with a discharge due to inflammatory and congestive processes, the walls readily become separated, and the inversion of the canal is facilitated either from below or above. That it more frequently begins from below is due to the frequent initiation of the mischief by the perineal defect which leads to exposure of the lower part of the anterior wall. Every mucous membrane subjected to unusual exposure is apt to become the seat of inflammatory changes, as may be seen in ectropion of the palpebral conjunctiva, or of the cervical endometrium; hence the perineal laceration leading to exposure of the anterior vaginal wall, is usually attended with chronic inflammatory changes, that lead to general colpitis with free discharge and thickening of the tissues that favour the production, first of cystocele and then of a more complete prolapse.

iii. Faults in uterine ligaments. — In some instances we trace the descent of the uterus, not so much to loss of power in the structures that support it from below, as to inefficiency of the structures that should retain it above. It is the relaxation of all its ligaments, utero-sacral and utero-vesical, broad and round, subsisting for some time after parturition, that facilitates the sinking down of the uterus which is so apt to be initiated during the puerperium. When these ligaments remain permanently relaxed and strained a more decided and permanent descent of the uterus ensues.

iv. Faults in the cellular tissues. — In the areolar tissues surrounding the pelvic organs, and filling in the interspaces between the layers of fascia in the different muscular planes, there is found in healthy women a considerable amount of fat. When absorption of this adipose deposit takes place, as in patients who are the subjects of wasting disease, and in some women at the climacteric period, a tendency to downward displacement of the uterus and vaginal walls is distinctly traceable. This

prolapse may be partly due to weakening of the ligaments, which is not unlikely to be present under such circumstances, but the absence of the normal fatty padding of the pelvis contributes in a notable degree to the result.

v. Faults in the pelvis. — We can understand that the contraction of the brim and expansion of the outlet, characteristic of the rickety pelvis, should favour the descent of the uterus; so that we sometimes find prolapsus uteri in virgins associated with this form of pelvis. In a secondary sense this, and other varieties of malformation, become causes of prolapsus in the damage that may be done during labour by the operative procedures which they render necessary. Besides, these changes in configuration are occasionally associated with changes in the inclination of the pelvis; and whenever the inclination of the pelvis is continuously disturbed, and the plane of the brim, instead of meeting the horizon at an angle of about  $55^{\circ}$ , becomes more or less parallel to it, downward displacements of the uterus are favoured. Such change from the normal inclination occurs in elderly women in whom the anterior curve of the lumbar vertebræ is lost, and in others whose avocations keep them for long periods of time in such attitudes that the promontory of the sacrum, instead of being four inches above the level of the upper margin of the pubic symphysis, is nearly in the same horizontal plane.

(b) *Active causes.* — Among the conditions that operate more directly in producing prolapsus uteri we note: —

i. Enlargements of the uterus itself. — In the early weeks of pregnancy, when the uterus begins to grow, it sinks slightly, so that the os is found at a somewhat lower level than in the case of the non-gravid organ. During the puerperium the descent of the uterus, which is rendered possible by the relaxation of its ligaments, is promoted by the increase in its own weight, which persists until its involution is complete. When the involution is interrupted, and the uterus remains enlarged in consequence of the subinvolution, or when it is hypertrophied as a result of chronic metritis, or from the development of neoplasms in its walls, the increase in weight of the organ is among the factors that tend to its depression. For though the hypertrophies of the uterus may sometimes be a result of congestive processes due to its displacement, in many cases the hypertrophy initiates the descent, and in any case it favours it.

ii. Distension of neighbouring organs. — Habitual over-distension of the bladder necessarily causes undue pressure on the pelvic floor and undue strain on the ligaments of the uterus with which the bladder is in such intimate relation; it must be regarded, therefore, as among the causes of uterine displacement. In a less degree habitual constipation has a similar effect.

iii. Increase of supra-pelvic pressure. — Of the causes that work actively towards the production of prolapsus uteri, however, the greatest importance is to be attached to those which produce their effect by increasing the pressure that is more or less continuously exerted on the pelvic contents. This supra-pelvic pressure is increased in cases of (a)

Relaxation of the abdominal walls. Such relaxation is especially apt to occur in multiparous women, especially where the walls have been over-stretched from the presence of unusually large children, or twins, or hydramnios. It may also be found in women who have been subjected to laparotomy for a large ovarian tumour. The abdominal walls are soft and thin, the muscular layers have lost their tonicity, and the so-called "retentive power" of the abdomen is impaired. The abdominal viscera, instead of being retained in their normal relations, tend to sink downwards; and so there comes about a continuous pressure on the pelvic viscera, which promotes herniation through the pelvic floor. ( $\beta$ ) In some cases the supra-pelvic pressure is increased from the presence of tumours in the abdominal cavity, or of ascitic accumulation in the peritoneal sac. More frequently it results from ( $\gamma$ ) Improper kinds of dress; as for example, where the waist is kept constricted by corsets too tightly laced, or heavy clothing is supported on bands round the abdomen. ( $\delta$ ) When a woman is under the necessity of making strong or long-continued muscular exertions, the pressure tells upon the pelvic contents; and in cases where prolapsus uteri is said to have occurred suddenly the displacement is usually attributed to some severe voluntary effort, or to an accident attended with strong muscular effort.

In considering the causes of prolapsus uteri we have to remember that the process of descent is a gradual one. Cases are met with from time to time where the patient has become suddenly aware of the mischief, and she may tell us that the protrusion was the result of an injury or strain. But when we inquire more carefully into the history, we recognise that, though the last stage of the displacement came on thus rapidly, there had been previous indications of disturbance; and when we make our physical investigation we find traces of long-standing change in the pelvic structures.

We have to keep in view, further, that we have to do, not with the effect of one of the above-named causes alone and independently, or even of one of the groups of causes, but with the combined influence of several of them acting continuously and for long periods. The women who are most subject to this displacement belong to the working classes; and in any individual sufferer the mischief is likely to have begun after a confinement attended by damage to the perineum. The patient, it may be, got up on the second or third day, and had to attend to her child and do her household work; or she may even have been obliged to follow some bread-winning avocation, whilst the womb was still large and its ligaments still relaxed. The passive conditions and the active causes conjoin in such a case to cause the displacement; if they operate month after month, and year after year, perhaps with aggravations from succeeding pregnancies, they inevitably produce a complete prolapse. The influence of any one of the factors may be slight; but it is associated with others which may have arisen independently; and their conjoint influence continues throughout long periods. Hence we cannot learn much of the production of prolapsus uteri by experiment



on the amount of force required to pull the os down to the vulva, and to bring it outside the orifice.

**Complications.** — Before proceeding to consider the symptoms and diagnosis of prolapsus, we must note that the displacement is constantly complicated with morbid changes in the displaced structures.

i. *In the uterus.* — Not only is the uterus, that has descended from its normal level, apt to be displaced backwards, it is commonly also the subject of a marked degree of hypertrophy. The hypertrophy may chiefly affect the body of the uterus. The organ may have been from the first in the state of subinvolution that so frequently gives a proclivity to displacement; or a chronic congestive metritis may have taken place during the course of its descent. All the walls are thickened and indurated, and the endometrium is expanded and vascular; until the menopause sets in, a patient with a prolapsed uterus is thus the subject of constant endometritis. In other cases, and more frequently, the inflammatory process is not confined to the body of the uterus; the cervix also is hypertrophied. The resulting elongation of the cervix may be found affecting the supravaginal and intermediate portions, so that the canal is more than double its ordinary length; whilst the anterior lip barely projects beyond the level of the anterior fornix. This state of matters obtains where the mischief has begun with exposure of the anterior vaginal wall from incompetence of the perineum. In other instances we have to do with a hypertrophy of the infravaginal portion of the cervix. The two lips of the os are usually found distinctly separated as a result of fissuring during labour, and both lips may be found thickened and elongated. If one lip be predominantly affected it is likely to be the anterior. This hypertrophy of the cervix is carefully to be distinguished from another variety of elongation of the infravaginal portion of the cervix uteri, which may be congenital in its origin, and in which such an elongation of the infravaginal portion exists, that the external orifice may appear at the vulva or even project beyond it, whilst yet the fundus of the unaltered body of the uterus retains its normal place at the pelvic brim. In the different forms of cervical hypertrophy the lining membrane shares in the growth and vascularity, so that we constantly find a catarrhal endometritis, both cervical and corporeal. The endocervical catarrh is likely to extend through the ectropic orifice, so that we frequently see catarrhal patches on the external surface of the lips; and when the prolapse has existed for some time in a complete form, the eroded surfaces are usually covered with a diphtheroid pellicle. It is noteworthy that the lids of the prolapsed uterus, so subject to simple inflammatory changes, very rarely become the seat of cancerous disease. Now and again an epithelioma is found in the protruded cervix, usually in women well past the menopause; but procidence of the ragged os of a multipara seems to confer on it a certain immunity from malignant degeneration.

ii. *In the vagina.* — Whilst the herniation is still in progress, the vaginal walls are in a catarrhal condition and covered with moisture.

When it is complete the surfaces that have become smoothed and deprived of their rugosities become perfectly dry; and in cases of long-standing eversion, the investing epithelium takes on in places the appearance of the epidermis of the skin. Eroded surfaces are not infrequently found in the neighbourhood of the cervix uteri covered, like those on the cervix, with a grayish shining pellicle. Very rarely ulcerative processes affect it more deeply, or an epitheliomatous degeneration may occur; but these are more likely to result from the action of ill-adjusted pessaries than from the long-continued displacement.

iii. *In the bladder.* — Imperfect evacuations of the distorted bladder are apt to lead eventually to cystitis; and in the diverticulum that pouches through the vaginal orifice below the level of the meatus urinarius concretions occasionally form. I have removed three vesical calculi from such a displaced bladder, complicating prolapsus uteri, which had formed in a woman from a district where stone in the bladder is almost unknown.

iv. *In the rectum.* — The rectum may be the seat of irritation and of undue lodgment of fæcal matter where the pouch of the rectocele projects distinctly below the anal aperture. Sometimes prolapsus recti is found in a patient with prolapsus uteri.

v. *In the pelvic peritoneum.* — As the appendages of the uterus follow it in its displacement, so they are likely to share in its inflammatory changes. The most important of the intrapelvic inflammations, however, to be noted in connection with descent of the uterus, is that which affects the pelvic peritoneum. When pelvic peritonitis is set up in this hernial sac it is apt to lead to adhesions of the apposed surfaces of the viscera in their distorted relations, and any attempt at reposition in such circumstances may be attended not only with suffering, but with danger to the patient.

**Symptoms.** — The symptoms that arise are due partly to the displacement, and partly to the attendant changes in the uterus and adjacent organs.

i. *Disturbance of uterine functions.* — The patient may have menorrhagia due to the endometritis. She has commonly leucorrhœa whilst the descent is in progress, and this discharge lessens or disappears when the prolapsus is complete. Conception may occur, and the displacements may prove troublesome during pregnancy or labour. As a rule the patient's reproductive power is lessened, and she has acquired sterility.

ii. *Disturbance of vesical or rectal functions.* — The patient may have frequent desire for micturition or difficulty in securing complete evacuation of the bladder or the rectum.

iii. *General pelvic disturbance.* — She may have difficulty in walking or in working with a mass protruded between the thighs. Even in the incomplete stages she may have a sense of weight and dragging in the loins or groins. In many cases all that the patient complains of is the presence of the uterus at the vulva or outside of it.

**Physical Diagnosis.** — When a patient comes to us complaining of a

falling of the womb, we may find her diagnosis of her own malady to be correct. Sometimes, instead of prolapsus uteri, we may find another displacement, such as retroversion or even inversion; or we may find that an intra-uterine fibroid has become pediculated, and is in course of extrusion through the canals. The body that has appeared at the vulva may be a mucous polypus from the cervix; or indeed it may be the cervix itself in a condition of hypertrophic elongation. There may be only cystocele or rectocele, without uterine dislocation; or a tumour growing from the vaginal wall may project through the vulva. The supposed fallen womb may even prove to be a swelling in some part of the external pudenda, such as a neoplasm or cystic accumulation, or simple hypertrophy; such was the case of a young lady, in whom the nymphæ were unusually long and dependent, whose mother thought her to be the subject of prolapsus uteri.

Complete prolapse of the uterus is usually very easily recognised on inspection. Hanging from the vulva between the patient's thighs is seen a mass, the size of a fist, pink in hue, or more purple if the tumour be congested, with a smooth surface except when erosive patches are present, and presenting at its lower anterior aspect the external orifice of the uterus. Around the os the labia sometimes form a projection; often it is difficult to trace the line of demarcation between the cervix and the vaginal wall. When the herniated mass is grasped between the fingers and thumb the outline of the entire uterus may sometimes be felt within. In other cases one feels only the elongated supravaginal portion of the cervix, round and hard; and the bimanual examination has to be made to ascertain the position and direction of the body of the uterus. The sound will at once distinguish the os uteri from a fissure in a fibroid tumour that might have descended to the vulva; and carried up through the canal the sound will give fuller information as to the length and direction of the uterus and the condition of its parietes. The sound (or a catheter) should further be used to determine the direction of the urethra and the exact relations of the bladder cavity; and a finger in the rectum adds to our knowledge of the size and place of the uterus, and demonstrates the degree of pouching that has affected the bowel itself.

In cases of incomplete prolapse, when we make inspection and tell the patient to bear down, we can see the unusual mobility of the anterior vaginal wall, and recognise the os as it becomes depressed towards the vulva; and the bimanual examination reveals to us the relations which the uterus has assumed in the lower part of the pelvis. In some cases the displacement, which is complete when the patient is in the upright posture, disappears when she lies on her back. Then the patient can be made to expel the womb by a downbearing effort; or it can readily be brought down by traction on the anterior lip of the os. We can thus demonstrate, as it were, the mechanism of the herniation. In our examination we have to keep in view not merely the displacement, but also the complications that may attend it; and we may see occurring rapidly the displacement which came about gradually under the com-

bined and protracted action of the various factors. Through the patulous vulva the anterior vaginal wall is exposed; as the patient bears down, or as we make supra-pubic pressure through the abdominal walls, the vesico-vaginal septum is seen to descend until the anterior fornix vaginae comes through the pudendal aperture, bringing with it the cervix uteri. First the anterior and then the posterior lip of the os externum appears; and, after the uterus has escaped, the posterior wall of the vagina becomes inverted, and the prolapsus is complete.

**Prognosis.** — When the uterus has sunk definitely and for some time from its normal level, it has no natural tendency to recover its proper place. Two physiological conditions may modify the course of the mischief.

i. *Influence of pregnancy.* — If the patient become pregnant, and due care be taken to prevent abortion or aggravation of the trouble during the first three months, she is likely to be freed from all the discomforts of prolapse; as the uterus from this time onwards rises out of the pelvis and becomes an abdominal organ. Sometimes by good management of the labour and the puerperium, the involution of the uterus may be so perfectly secured, and the tonicity of its ligaments so far restored, that at least a partial cure may be attained. On the other hand it more frequently happens that the displacement recurs after the patient gets up; it may be, in an aggravated degree.

ii. *Influence of the menopause.* — At the menopause the herniated organs usually undergo the ordinary process of senile atrophy that will lead to a diminution in the size of the swelling and relief from some of the attendant symptoms. The relaxation of the ligaments and loss of the fatty padding of the pelvis incidental to this period of life sometimes, however, allows of further descent of the uterus; so that now the patient applies for relief for the first time: and it must never be forgotten, in the cases where pessaries have been long worn in the vagina, that the shrinkage and loss of vitality in the walls may lead to ulcerative processes to which the tissues had shown no previous tendency.

**Treatment.** — A prudent practitioner in his midwifery practice will keep in mind the risks to which a woman is subject who comes out of her confinement with a damaged perineum, relaxed uterine ligaments, and subinvolution of the uterus. He will note during labour the conditions that endanger the perineum and seek to avert its laceration. Where laceration has occurred he will see to its immediate repair, bringing together the raw surfaces with sutures at the close of the third stage, or within twelve hours thereafter. He will guide the convalescence, and see that no undue exertions are allowed until the ligaments have recovered their tone, and the uterus is restored to its non-gravid dimensions. By such prophylactic measures he saves his patient from the beginnings of a displacement which may cause little disturbance at first, but which will go on to increased distress, and may be a source of trouble for a lifetime.

Where the prolapsus uteri is complete the indication for treatment is twofold: to reduce; and to retain the displaced organ.



i. *Reduction of the uterus.* — The uterus, which is completely prolapsed when the patient is in the upright position, is often reduced of itself when she lies down; so far, at any rate, as to disappear within the vaginal orifice; or when not spontaneously replaced it may be made to return with the gentlest amount of pressure. Occasionally some degree of force must be exerted; and in performing taxis in such cases the practitioner has to keep in mind the manner in which the herniation occurred, and to seek to replace the structures in the reverse order to that in which they descended. He begins with the posterior wall of the vagina, which was the last to escape, and presses it past the perineum. The uterus follows, first the posterior and then the anterior lip of the cervix. Last of all the anterior vaginal wall is replaced. It is especially in such cases that the anterior wall is found to have become greatly thickened, widened, and indurated in its texture. In some instances the prolapsed mass is so swollen and congested that the patient must be kept at rest for some days before the reduction can be safely effected; and during that time she may use a hot sitz bath, or have a stream of hot water made to play over the tissues two or three times a day, so as to reduce the hyperæmia. It may even be necessary, for this purpose, to make some scarifications on the surface to relieve the vascular tension. Where an active peritonitis is present, or peritonitic adhesions have formed among the displaced viscera, rude or rapid manipulation would be attended with danger; and prolonged antiphlogistic measures should be employed before the attempt is made to replace the organs. In all cases the reposition should not only be preceded, but also followed by the adoption of an antiphlogistic treatment calculated to lessen the uterine hypertrophy, and of measures calculated to restore the tonicity of the pelvic tissues. With this view it may be necessary to curette the uterus, and to apply iodine and carbolic acid to the interior; to administer ergot and quinine, or such deobstruents as the iodide and bromide of potassium; to use such waters as those of Kreuznach, Krankenheil, Ems, or Kissingen, and to enjoin the use of hot and astringent douches.

Massage has been employed for the relief of this as of other pelvic mischiefs; and Thure Brandt, who by his successful treatment of various uterine disorders has induced some members of the profession to adopt the practice in recent years, has suggested a mode of reduction of the prolapsed uterus which has been followed by various gynæcologists in different countries with encouraging results. The patient under treatment is placed on her back with her knees bent up; and, while an assistant pushes up the pelvic organs through the vagina, the operator lays hold of the body of the uterus with the finger-tips of his two hands pressed through the abdominal walls at the pelvic brim. When he feels that he has the uterus between his hands, with a kind of wriggling movement he pulls it upwards as far as possible into the abdominal cavity. This uplifting of the organ has to be repeated daily, or at short intervals; and the congestive processes are at the same time relieved by friction applied to the uterus and its adnexa through the uterine parietes. But, besides

acting thus on the uterus and appendages, the operator, placing himself at the foot of the couch, tells the patient to keep her knees as tight together as possible, whilst he forcibly abducts the thighs; and again he tells her to try to keep the knees apart whilst he forcibly brings them together. The effect of this alternate action of her adductor and abductor muscles is to increase the vigour of the muscular structures within the pelvis. This is further favoured by stimulation of the lumbar muscles, and gymnastic exercises calculated to develop the patient's muscularity, but these are not essential to the cure of the prolapsus. Those who have succeeded in this "kinesitherapeutic practice," as it has been called, have expressed the conviction that it will lessen the frequency of surgical operations; but it is admitted that the method is not quickly learnt, and that its application requires long fingers, a supple hand, muscular activity and dexterity, and inexhaustible patience.

ii. *Retention after replacement.* — The reduction of the prolapsed uterus is usually easy of accomplishment. It is far otherwise with its retention in place. The attempt to fulfil this indication may be made either by the application of some kind of support; or by the employment of some operative procedure. The former line of treatment is for the most part merely palliative; the latter aims at a more radical cure.

(a) *Palliative measures.* — Among the means we have been employing to reduce the inflammatory conditions in the pelvis an important place will have been given to the use of pledgets of cotton soaked in glycerine. For deobstruent purposes the glycerine will have been medicated with ichthyol; where a more astringent action is desired an astringent like tannin will have taken the place of the ichthyol. These pledgets of cotton may so fill up the vaginal cavity as to have at the same time the effect of supports to keep the uterus in place. Or the vagina may be packed tensely with iodoform gauze or salicylated cotton wool; when the packing has again the double function of keeping up the uterus and promoting absorption of inflammatory deposits. Such vaginal tampons require to be changed every two, three, or four days. Patients can wear a tampon of marine lint for a week without any discomfort; but a woman cannot be expected to go on for any length of time using vaginal tampons that may require the assistance of the medical attendant for their proper application. Accordingly, when these have fulfilled their function in lessening the pelvic congestion, and have demonstrated that a foreign body can be retained in the vagina which prevents the recurrence of the prolapse, the practitioner has to consider what kind of vaginal pessary will be likely to keep the patient comfortable. Now the variety of vaginal pessaries is endless. There are differences in —

(a) The material of vaginal pessaries. — They are sometimes made of metal. Of these the most practical are the rings made of some flexible material that allows of changes in their form to suit individual cases. Pessaries of wood were at one time in frequent use; and they have been made also of ivory, bone, and of soft materials covered with some impervious substance. These have now been almost entirely replaced by

india-rubber, either in its soft state or in the hard state of vulcanite. The soft rubber pessaries have the advantage of easy application to a wide range of cases: the drawback to their continuous employment is their tendency to lose elasticity when they lie for a length of time in the vagina; at the same time they absorb secretions and become the source of disagreeable discharges. The pessaries of vulcanite can be worn for long periods, without undergoing any change or becoming the source of any trouble, if care be taken to see that they are properly adapted. They can be modified in form by being placed for a minute in boiling water; but they are apt to break when attempts are made thus to change their curves: hence it is necessary for the gynaecologist to have a set of vulcanite pessaries of different size and outline always at hand. If he can procure pure gutta-percha he has at his command a material out of which he can fashion a pessary for any given case. In boiling water gutta-percha becomes so soft that a piece of the proper size can be rolled between the palms of the hands till it has the form of a smooth round ball; and further manipulation can then mould it into the form of a disc and stem, of a hollow perforated disc, or of a simple ring or horse-collar, according to the requirements of the case. Patients have sometimes worn gutta-percha pessaries for years with comfort. But, as the material is somewhat porous, it is better for the practitioner, when he has found the form and size that suits his patient, to send the gutta-percha instrument to the manufacturer in order to have one of the same pattern modelled in vulcanite. The only material that can compete with vulcanite in lightness, smoothness, and freedom from irritation in the vagina is celluloid.

( $\beta$ ) The shape of vaginal pessaries.—Globular or egg-shaped pessaries, hollow and made of vulcanite, are very serviceable where the perineum has still some retentive power, and the patient suffers from a tendency to descent of the vaginal walls and the uterus; especially in elderly women. In many cases the ring pessary gives satisfactory results. The soft india-rubber ring is easily introduced and adapted to the vaginal cavity. It should be carried up so as to lie in the vaginal roof, the posterior being higher than the anterior border, and should find its support on the upper surface of the plane of the levator ani. Where there is a marked degree of cystocele the ring should be filled with a perforated diaphragm which serves to retain the anterior vaginal wall better in position. The soft pessary, however, should not be left for prolonged wear; but if the ring give comfort it should be replaced by one of vulcanite or celluloid. Instead of a simple ring, a pessary that is discoid or saucer-shaped will often retain the structures better in position. Such a pessary holds all the better if the posterior border be made thicker than the anterior; and it may be worn for many months without any discomfort. A series of perforations allows of the free escape of the menstrual discharge, and allows of the washing out of the vaginal cavity with the douche. Where the ring or the saucer-shaped pessary fails to keep in place, the herniation can sometimes be prevented by making the patient wear a disc and stem



pessary; the stem projecting from the lower surface of the disc lies between the labia. The disc may be circular, but is better elongated from side to side so as to keep the walls of the vagina extended transversely. The patient learns easily to introduce such a pessary as she lies on her back, by passing in first the one side through the vaginal orifice and then the other, as a button is passed edgewise through a buttonhole. She removes it from time to time when going to bed by laying hold of the stem with the finger and thumb of one hand, while the forefinger of the other hand lays hold of one edge of the disc and presses it out. She can thus secure the cleanliness of the instrument and, if need be, she can douche the vaginal cavity in the interval of removal. The Zwanck and other pessaries with hinges and screws are all unsatisfactory.

When the ball, the ring, or the discoid pessary fail in consequence of extensive lacerations of the perineum, or relaxation in the muscular planes of the pelvis, the patient may still obtain some relief from her displacement by wearing an abdominal bandage in addition to the pessary. A perineal strap passing between the patient's thighs will keep the pessary in place; or the pessary may be fixed to the bandage by a curved metallic rod, or by elastic bands. But as in the case of patients with an inguinal hernia where a truss does not give relief, the surgeon proposes to the patient an operation for the radical cure, so here, when there is a multiplicity of arrangements required for the relief of the pelvic hernia, the gynæcologist will suggest that it is better to have recourse to some operative procedure likely to effect a cure of her condition.

(b) *Operative measures.* — There are four different directions in which he may proceed to effect his purpose of securing the uterus in its proper place, and he is guided in his choice partly by the primary fault which initiated the displacement, and partly by the changes which have ensued in the dislocated structures. He may seek ( $\alpha$ ), to lessen the pudendal aperture; ( $\beta$ ), to narrow the vaginal canal; ( $\gamma$ ), to diminish the size of the uterus; ( $\delta$ ), to tighten the uterine ligaments. In some cases a single operation suffices to remedy the mischief; in others two or more of the operations must be carried out in the same individual, and usually he finds it best to perform them all at once rather than at intervals.

(a) *Operations on the pudendal aperture.* — The frequency with which the dislocatory process follows relaxation or rupture of the perineum warns us that in a large proportion of cases an essential element in the radical cure will consist in the tightening of the pelvic floor and narrowing of the pudendal aperture. Where the orifice has become preternaturally wide without laceration of the perineum, the operation that constricts it is designated *episiorrhaphy*; where a damaged perineum must be repaired the operation is a *perineorrhaphy*. Various methods have been followed in the attempt to narrow the aperture and to strengthen the pelvic floor in one operation, by making a raw surface extending round the posterior half or two-thirds of the vulva, and bringing it together from the two sides with a series of sutures. The best results are obtained, without removal of any of



the mucous membrane, by splitting off the vulvo-vaginal mucous membrane from the subjacent tissue either with a knife or, more rapidly, with a pair of scissors. The anterior extremity of the incision on each side comes at least as far forward as the base of the nymphæ, and the dissection of the mucous membrane proceeds through the whole extent of the perineum until the point is reached that corresponds to the junction of the middle and lower third of the vaginal canal; there some areolar tissue only intervenes between the vagina and the rectum. Where the perineal damage has invaded the anal canal the recto-vaginal septum has to be split higher up; and while the dissection is carried forward to the usual extent in the direction of the nymphæ, in this case it must also be carried backwards around the anal gap beyond a dimple or depression which can usually be seen in the cicatricial tissue on each side, indicating the point of insertion of the ends of the sphincter ani which is torn across. Such dissection produces a raw surface of large extent, in the sides and depth of which the torn or relaxed musculo-fascial tissues are freely exposed. These may now be brought together by means of a continuous catgut suture, which is introduced at first in the centre of the vaginal flap and is carried backwards towards the anal margin from side to side in the depth of the wound. It then runs forward, laying hold of the sides of the wound in the middle of the raw surface; and the next stage, which again runs backwards, brings the edge of the wound into close apposition.

( $\beta$ ) Operations on the vaginal walls. — When pessaries have been left so long unattended to in the vagina that they have produced ulcerative processes in the vaginal walls, their removal is sometimes followed by a cicatricial contraction of the canal which makes the patient independent of further aid. In such patients, however, the non-recurrence of the prolapse is not due simply to the narrowing of the hernial canal, but to the changes that have taken place also in the uterus and its ligaments; for they are usually women who have passed the climacteric period with its atrophic processes, and the uterus has long been kept up in its normal place. The attempt to prevent prolapse by producing a cicatricial ring in women at an earlier age, and whilst the uterus is still subject to its menstrual changes, is not encouraging in its results. A circular ulcer has been made by means of the actual cautery high up in the vagina; or a tape has been passed round underneath the mucous membrane and tied so tightly as to ulcerate its way out. The circular scar, however, that results is continuously strained by the heavy uterus, and, receiving no support from the relaxed tissues below, becomes distended in no long time; the uterus thus sinks through, and the whole prolapse is reproduced.

The most satisfactory results are obtained by the procedures that narrow the vagina, not in a circular, but in a longitudinal direction. Raw surfaces two inches in length and nearly as broad, made on corresponding portions in the middle of the anterior and posterior walls, have been brought together so as to produce a strong bridge which prevents prolapse; or the anterior and posterior walls have been sewn together after

the mucous membrane has been dissected off the sides of the canal. The procedure that is usually indicated has been called anterior or posterior *colporrathy* or *elytrorrathy*, which signify a narrowing of the anterior or posterior wall of the vagina throughout their length. In some cases the posterior colporrathy constitutes part of the operation for perineal repair, some portion of the redundant mucous membrane on the back wall of the vagina being dissected off, and the wound closed by sutures running from side to side so as to narrow the cavity just above the perineum. Most frequently the indication is for an anterior colporrathy. The anterior vaginal wall was the first part to undergo displacement; it gradually becomes distended, thickened, and indurated; and whilst these changes may be modified by keeping the patient at rest, by the wearing of pessaries, or by narrowing of the vulvar orifice, they can only be effectually removed by a surgical operation. A circular portion of the mucous membrane may be dissected off the most prominent part of the wall, and the wound closed like the mouth of a purse by a suture that runs round the margin. Raw surfaces about half an inch in breadth may be made towards the side of the wall, and brought together in the centre of the canal by means of silver sutures kept in place for three weeks. These raw surfaces are wider apart in the fornix and converge toward the urethra. Better still it is to make an elongated elliptical wound surface, the upper end of which begins close to the cervix uterus, widening as it goes down till in the middle the entire breadth of the wall is denuded of its mucosa, and narrowing again as it comes down toward the urethral orifice. A continuous catgut suture closes the wound in stages. Introduced at the urethral end, it narrows the raw surface as it is carried from side to side till it reaches the cervical end; as it is carried down again towards the lower extremity it brings the sides of the wound together near the mucous membrane at the widest part; and in its third stage, as it is again passed upward, it will bring together the mucous membrane at the margins. This operation narrows the anterior wall, constricts the vaginal canal throughout its length, and, when conjoined with the perineal repair which is likely to be required, gives the surest hope of a radical cure in the great run of cases of prolapsus uteri.

( $\gamma$ ) *Operations on the uterus.*—When the uterus itself is enlarged, whether primarily or secondarily, it becomes necessary to secure its diminution by other than the ordinary antiphlogistic measures. This often occurs spontaneously to a remarkable degree during the time when the patient has to keep at rest after a perineorrhaphy or colporrathy; and will all the more certainly and completely take place if these operations have been preceded by a curetting of the uterine cavity. If cervical hypertrophy be present, amputation of the cervix, or of some portion of it, may form the leading indication. It may be that one or both of the lips or the entire infravaginal portion has to be removed, and when the patient has recovered from the effects of the operation the uterus will retain its place. In other instances the amputation must go further; the intermediate portion must be dissected from the bladder so as to allow of its

removal. Extirpation of the entire uterus has sometimes been carried out. In most of these cases of prolapse vaginal hysterectomy will be easy of accomplishment; but this operation should be reserved for patients in whom there is some tendency to malignant degeneration.

(δ) *Modifying the supports of the uterus.* — Two different procedures that were proposed in the first instance for the cure of backward displacements of the uterus, have been found serviceable in some cases of descent. These are the shortening of the round ligaments, suggested independently by Dr. Alexander of Liverpool and Dr. Adams of Glasgow, and usually named, after them, the Alexander-Adams operation; and the fixation of the uterus to the abdominal parietes; the so-called *ventro-fixation* or *hysteropectia*. Various gynæcologists, both British and foreign, have reported favourable results from the employment of these procedures; but the range of their applicability has not been clearly defined, and where they are undertaken the patient should be made aware of the attendant risks.

### B. DEVIATIONS IN POSITION

The uterus may be placed unusually far (i.) backwards, in a state of retro-position; (ii.) forwards, in a state of antero-position; or (iii.) to one or other side — right or left — lateri-position. These displacements of the uterus may be due, on the one hand, to tumours, inflammatory effusions, or hæmorrhagic extravasations pushing the organ out of its place; or, on the other, to peritonitic adhesions or cellulitic contractions pulling it in another direction. For example, a cellulitic swelling in the left broad ligament in its early acute stage will thrust the uterus towards the right side of the pelvis; and if the inflammatory process end, as it sometimes does, in producing an atrophy of the ligament, the uterus will eventually be dragged towards the left side. So a peritonitic effusion in the pouch of Douglas, in the acute stage, will press forward the uterus which, at a later period, if the parts become fixed by inflammatory adhesions, will be retro-posed. It is obvious that these malpositions of the uterus do not constitute the central phenomenon in any individual case; still it is important to keep them in mind, because they are often found complicating some of the other displacements, and obscuring the diagnosis.

They can usually be recognised by means of the bimanual examination supplemented, if need be, by the use of the sound or volsella: their treatment falls under the treatment either of the causes that produce them, or of the displacements with which they co-exist.

### C. DEVIATIONS IN DIRECTION

The uterus is subject to changes in the direction of the fundus, which may be displaced backwards, forwards, or to one or the other side. In either case there are two different conditions of the uterus itself to be observed: in one, the whole uterus is more or less rotated on its axis, the

body and the neck of the uterus form a straight line, the uterus is in a state of version, and we have retroversion, anteversion, or lateriversion. In the other case the body has mainly or alone undergone the change; the body is bent on the neck, the uterus is in a state of flexion, and we have to do with retroflexion, anteflexion, or lateriflexion. The most important, from the practitioner's point of view, are the —

I. **POSTERIOR DEVIATIONS.** — These have sometimes been described under the convenient designation of retrorsions — a term which includes the cases where the entire uterus is displaced, the retroversions, and those where the body chiefly is displaced and bent on the cervix — the retroflexions. In a simple retroversion the uterus has lost its tendency to fall forward towards the symphysis pubis; the organ is to some degree stiffened so that the cavity of the body and canal of the cervix form a continuous line; and it has become rotated on its axis so that the fundus remains permanently directed towards the sacrum, and the os, instead of looking backwards, is directed downwards or forwards according to the degree of version that has been established. The varying degrees of retroversion in individual cases should be estimated by noting whether the fundus is directed towards the promontory of the sacrum, or towards the first or a lower sacral vertebra. In a case of retroflexion the uterus has not only lost the normal anterior inclination, the body has also become permanently bent backwards. The os may still look backwards; but, as in most cases of retroflexion there is some degree of retroversion present, the os will come to change its direction also: thus in well-marked cases the fundus is found lying in the lowest part of the pouch of Douglas, and the os looking towards the lower margin of the pubic symphysis.

**Causes of Retrorsions.** — Before studying causes on the part of the uterus itself, on the part of its ligaments, or on the part of the influences that tend to bring about these changes in the direction of the uterus, we may note that some cases are: —

i. *Congenital.* — On post-mortem examination of infants and young children the uterus is sometimes found retroverted or retroflexed to a degree not to be accounted for by the dorsal decubitus of the body. In young married women the displacement may be present when there is no antecedent history to lead us to suppose that ordinary operative causes have been at work. I have seen two sisters, one married and the other single, suffering from retroflexion; and the displacement reappearing in the two daughters of the married one. This congenital displacement is sometimes associated with elongation of the cervix or with shortening of the vagina, notably of the anterior wall; but it may also occur without any concomitant deformity.

ii. *Changes in the uterus.* — Whatever causes tend to produce (*a*) induration of the uterine tissues, and so to destroy its normal flexibility, tend to bring about a version of the organ. Subinvolution, chronic metritis, and tumours in the walls, which make the organ rigid and unable readily to accommodate itself to the distensions and evacuations of the neighbouring organs, especially of the bladder, render it liable to be



affected by the influences that press the fundus backwards, and so to suffer retroversion. Hence the frequency of this displacement in women who have given birth to one or more children, and have subsequently remained sterile; for these chronic inflammatory changes in the uterus are very apt to arise in connection with puerperal processes, whether they begin in the placental site, as suggested by the elder Martin, or in other parts of the uterine parietes. When the anterior wall is chiefly affected a retroversion will result; and this the more certainly the lower down in the wall the thickening is situated. (b) Of relaxation of uterine structure retroflexion is more likely to be the consequence. In cases of persistent retroflexion a notable atrophy of the posterior wall is usually found at the point of flexure which corresponds to the isthmus. In some instances this may be a consequence and not a cause of the flexion; but in others loss of substance as well as loss of tone precede the displacement and favour its occurrence; and in some patients, where both anterior and posterior walls are found thus thinned and relaxed at the isthmus, the uterus is liable at one time to be retroflexed and at another in a state of exaggerated ante flexion.

iii. *Changes in the ligaments.* — It is in the loss of retentive power of some of its ligaments that we most frequently find the explanation of a retroversion. When (a) the utero-sacral ligaments are relaxed the cervix is liable to be carried too far forward, and then the fundus is likely to fall backwards; (b) the retroversion is favoured when the round ligaments are relaxed, and fail in their function of keeping the fundus directed towards the abdominal wall: but whilst loss of tone in the utero-sacral and round ligaments is the most important element in the production of retroversion, we note (c) that the changes in these ligaments are frequently conjoined with relaxation of the broad ligaments and of the structures in the floor of the pelvis. We have seen, in dealing with prolapsus uteri, how influential are these conditions in leading to descents of the organ; and we then note that descent is apt to be attended with retroversion and retroflexion. There is, however, another ligamentous change which may be chargeable with the production of a backward deviation of the uterus. This occurs when (d) the utero-vesical ligaments are shortened as a result of chronic inflammation. The tense structures dragging the isthmus forwards, or keeping it somewhat immobile, prevent the uterus as a whole from making the excursions in various directions demanded by its relations to the neighbouring organs. The body remaining more mobile than the cervix, and retaining its normal flexibility, is apt to be turned back into the hollow of the sacrum, and a retroflexion is thus established.

iv. *Directly displacing influences.* — Of the influences that tend immediately to produce retro-deviations of the uterus, we may note — (a) A strain or fall or other jar to the body which has sometimes preceded the appearance of symptoms associated with a retroversion or retroflexion of the uterus. In some such cases the pre-existing displacement may not have been recognised; in others it is easily conceivable that a displace-

ment could be thus brought about, especially if at the time of the accident the fundus were lifted backwards by a distended bladder. (b) Habitual over-distension of the bladder, which will keep the fundus uteri directed to the promontory of the sacrum or beyond it: and a patient in whom the uterus is frequently in this situation will readily acquire a permanent retroflexion; and this all the more if the bowels have a tendency to constipation and require straining efforts for their evacuation. (c) A permanent backward fixation of the uterus which, in some cases, is a result of peritonitis leading to adhesions that bind the posterior surface of the uterus to the rectum and back wall of the pelvis.

**Complications.** — When tumours of the uterus itself or of the neighbouring organs are associated with retroversion the displacement is of minor moment, and it usually disappears on removal of the growth. The most important complications depend on the tendency to inflammatory changes in the uterus. These inflammations are sometimes the cause, sometimes the consequence of the displacement; in either case the displacement and inflammation tend to perpetuate and to aggravate each other. The inflammatory mischief may be found in the perimetrium, leading to fixation of the uterus in the pouch of Douglas; or it may affect the mesometrium, producing a rigidity that especially perpetuates the retroversions. Most frequently the endometrium is affected; and there is a chronic catarrhal process in the cavity of the uterus, which is likely to spread along the cervical canal and to pass out on the posterior lip in the form of an extensive granulating catarrhal patch. Among the most troublesome cases are those in which the retroversion is complicated with prolapse of the ovaries, because these glands are usually congested and tender when they become thus displaced, and may cause trouble in the adjustment of pessaries which, in other cases, would serve to retain the uterus in position and relieve the patient of her suffering. Moreover, it has often been found on section that retroversions of the uterus have so far interfered with the function of the ureters as to have produced some degree of hydronephrosis. This rarely attracts attention during life; but it is noteworthy that a considerable proportion of women, who are the subjects of movable kidney, have at the same time some uterine displacement, most frequently in the form of retroversion or retroflexion.

The **symptoms** of retrorsions of the uterus are due partly to the displacement, and partly to the inflammatory changes that so frequently accompany or flow from it. They consist of —

i. *Disturbance of uterine functions.* — This disturbance may affect either the menstrual or reproductive functions, and in many cases both of these functions are disordered.

(a) *Menstrual disorders.* — While an amenorrhœic patient may have a retroflexed uterus, as in some cases of superinvolution or in some cases of hydrometra or hæmatometra, patients who are the subjects of retroversion or retroflexion usually suffer from increase of the menstrual flow; in many instances, indeed, it is because of the menorrhagia that they seek

advice. The excessive flow, however, is symptomatic of the attendant endometritis rather than of the mere displacement. Sometimes dysmenorrhœa running throughout each menstrual period is a leading symptom; and whilst in some cases this also finds its explanation in the inflammatory condition of the uterus, in others it is associated with the displacement; especially in cases where the uterus is so retroflexed as to have lost its erectile power, and where mechanical straightening of the organ relieves the menstrual pain. Intermenstrual discharges, again, presenting any of the characters of leucorrhœa, are most frequently due to catarrhal processes in the cervix or body of the uterus.

(b) Reproductive disorders. — If retroflexion be found in a patient who complains of dyspareunia, the explanation of the suffering will usually be found in some of the complications that are present — such as vaginismus or oophoritis — unless the displaced organ be itself the seat of an active inflammation. Sterility, on the other hand, is often the result of retroflexion, and thus a leading symptom of it. This may be the case in women who have never conceived. I have treated, for instance, two sisters in each of whom, after two or three years of childless marriage, the uterus was found retroflexed; in both of them conception occurred after the uterus had been replaced with the sound and kept in place with a vaginal pessary. Still more constantly one finds the uterus turned back in the case of women who have given birth to one or more children and then cease to conceive. There are others, again, in whom conception occurs from time to time, but who bear no more children because, with a retroverted uterus, they become the subjects of habitual abortion.

ii. *Disturbance of neighbouring organs.* — We have seen how much the positions of the uterus are modified by the changing relations of the adjacent viscera. When it loses its power of adaptation to these organs, and is persistently displaced, it may prove a source of irritation to them. Hence we have —

(a) Interference with the rectum. — The patient sometimes suffers from mucous dejections and frequent desire for defæcation; more frequently there is obstruction to the easy escape of the intestinal contents, and the bowels are emptied with severe straining efforts.

(b) Interference with the bladder. — The bladder may be unaffected; but the patient who has a retroverted uterus is liable to suffer from frequent calls to micturition, or difficulty in evacuation of the bladder, especially if the uterus be at the same time enlarged. A patient who has not menstruated for two or three months and suffers from retention of urine is almost sure to have retroversion of the gravid uterus.

(c) Interference with pelvic muscles and nerves. — Patients with retroversion or retroflexion of the uterus sometimes seek advice because of pain referred to the pelvic cavity, to the sacrum, or to the lower extremities. In some the suffering is aggravated by any kind of exertion; in others, where there is no pain, there is loss of power in the lower extremities, so that the patient appears paraplegic, and is only able to walk when the uterus has been righted and retained in its proper place.



(d) General constitutional disturbance. — Besides the more localised symptoms we may find the patients complaining of derangements of more distant organs, such as the reflex neuralgias, gastric distress, mammary irritation, and general depression that are so often associated with other forms of uterine trouble.

The **diagnosis**, however, of a retroversion or retroflexion of the uterus cannot be founded merely on these functional symptoms. It can only be made out by direct physical examination.

i. *Abdominal palpation* gives negative results.

ii. *Vaginal exploration*. — The finger introduced into the vagina finds the os looking downwards or even directly forward; the anterior fornix empty; and the posterior fornix occupied by a rounded resistant body, which, if a second finger be introduced, is felt to be continuous with the cervix and to move in concert with it. To acquire certainty as to the condition our great reliance is placed on —

iii. *Bimanual examination*. — The fingers of the left hand applied to the hypogastric region press down the uterus and its adnexa so deeply into the pelvis that the index and medius of the right hand, by which the vaginal exploration is made, get more fully into contact with all the pelvic viscera. The forefinger being placed on the cervix uteri and the middle finger in the posterior fornix vaginae, the exact relations of the uterus can in most instances be distinctly defined. If it be retroverted the body is found running directly backwards whilst the os looks forward; and if there be retroflexion the angle at which the body is bent on the cervix can be felt. In this manner, after a little experience, the practitioner succeeds in diagnosing the condition with the greatest certainty. Occasionally greater certainty is attained by introducing the medius into the rectum whilst the index explores by the vagina.

iv. *Use of the sound*. — As gynæcologists first learned to appreciate the frequency of retroflexions of the uterus by the use of the sound before the bimanual method had been fully developed, so the young practitioner will often find it useful to satisfy himself of the direction of the body of the uterus by passing the sound in a case where his bimanual exploration still leaves him in doubt. There are even cases where the most experienced gynæcologist is glad to avail himself of its services; especially if the displacement be associated with tumours or with hæmorrhagic or inflammatory effusions. There are cases where the bimanual examination is impeded by the thickness, or painful because of the tenderness of the abdominal walls; the passage of the sound then speedily and painlessly clears up the diagnosis.

v. *Other aids to diagnosis*. — The volsella may sometimes be used to pull upon the cervix, or the speculum may be introduced to determine the condition of the lips of the os uteri. For determination of the displacement in itself they are unnecessary. But to get the full benefit of bimanual examination it is often necessary to bring the patient under an anæsthetic. This becomes the more necessary where any tumours or adhesions are likely to interfere with the easy reposition of the organ;



indeed, it may be dangerous to the patient to undertake the treatment of a case when these are overlooked.

**Prognosis.** — “Ils ne tuent pas, mais ils ne guérissent pas,” said Velpeau in one of the discussions in the French Academy of Medicine, when some of his confrères who were averse to the employment of pessaries argued that displacements of the uterus were not dangerous to life. Retroversion or retroflexion of the uterus are assuredly not conditions likely to prove fatal, but they may be sources of life-long discomfort. The only conditions under which a patient with this displacement may get rid of her trouble would be (i) in the rare cases where, having escaped the danger of abortion, she has carried a child to the full term, and a normal involution of the uterus and its ligaments has been secured during the puerperium; or (ii) when the uterus undergoes such atrophy as sets in at the menopause.

**Treatment.** — When a retroversion or retroflexion of the uterus is found in a patient who comes complaining of the symptoms described in the preceding paragraphs, the practitioner, before proceeding to deal with the displacement, must make sure that it is an uncomplicated case. In a very great proportion of instances the first indication he has to fulfil is —

i. *To combat the complications.* — Among these the inflammations in and around the uterus hold a foremost place. It is sometimes difficult to determine whether the patient's distress be more due to the inflammation or to the displacement; and it often enough happens that under antiphlogistic measures the walls of a rigidly retroverted uterus become softened, or the flaccid walls of a retroflexed uterus recover their tonicity and the organ rights itself. So perimetritic adhesions may become relaxed, cicatricial indurations of the utero-vesical ligaments may disappear, or tension be restored to utero-sacral ligaments that had lost their contractility; spontaneous reposition of the displaced viscus may thus come about. When, after inflammatory conditions have been removed, the uterus retains its abnormal place, the inflammatory changes will all recur unless the uterus be replaced. There are many cases, moreover, where reposition of the uterus, without special antiphlogistic treatment, is followed by removal of the congestive and catarrhal symptoms. The next indication, accordingly, is to —

ii. *Replace the uterus.* — Various methods have been adopted for securing the reposition of the retrorse uterus.

(a) *Posturing the patient.* — When the patient is placed in the knee-elbow posture, and the perineum is pulled back, so as to allow the vagina to be filled with air, the vaginal roof, carrying with it the uterus, can be seen and felt to have fallen away downwards and forwards. This posturing of the patient and manipulation of the parts has sometimes been used for the purpose of replacing the retroverted uterus. The manœuvre has been specially commended under the idea that the patient by adopting it might succeed in freeing herself of the displacement. But whilst in a few cases of retroversion the uterus

might by this means fall into its normal relations, in the great majority it will fail to do so. In them, and in all cases of retroflexion, when the patient is put in the genu-pectoral position and the perineum held back, it becomes necessary to pull the cervix downwards and outwards with a volsella grasping the anterior lip of the os, while the fundus is pushed into its proper place either through the posterior fornix vaginae or through the rectum.

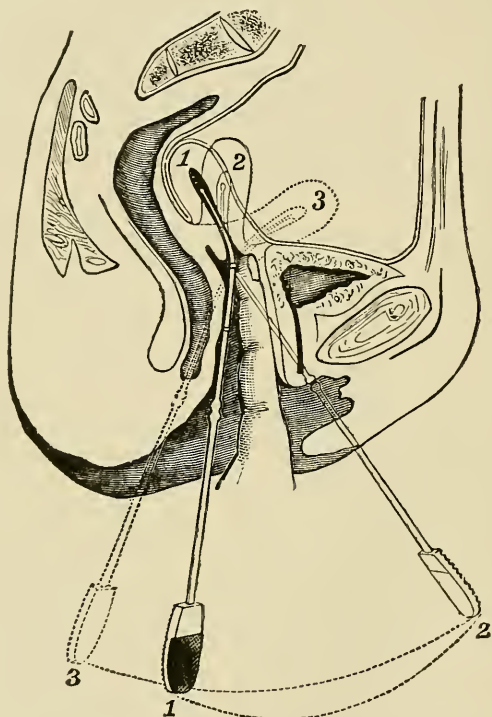

FIG. 118. — Reposition of the retroverted uterus with the sound.

(b) *Bimanual reposition.* — When a patient has been chloroformed for the purpose of careful diagnosis the best method of reposition is by the bimanual procedure. The fingers of the one hand are pressed through the abdominal walls towards the hollow of the sacrum; and, while the middle finger of the other hand pushes the fundus upwards to bring it within reach of the abdominal fingers, the forefinger is used to push the cervix backwards until, under the concerted action of the two hands, the fundus is carried right forward to the symphysis pubis. Occasionally the fundus can be pushed up better by the medius inserted into the rectum. Even when the patient is not anæsthetised this manipulation can in many cases be carried out without much difficulty, especially where the abdominal walls are thin and flaccid.

(c) Reposition with the sound. — When the practitioner is satisfied that he has to do with a uterus that is not bound down by adhesions, his simplest and speediest method of reposition is by means of the uterine sound. It can be effected with perfect safety if the operator be careful to move the handle through a wide area, as the point of the sound turns within the uterine cavity (see Fig. 118); and in this, as in other methods of reposition, it is necessary to carry the fundus uteri far forward till it comes to lie close to the symphysis.

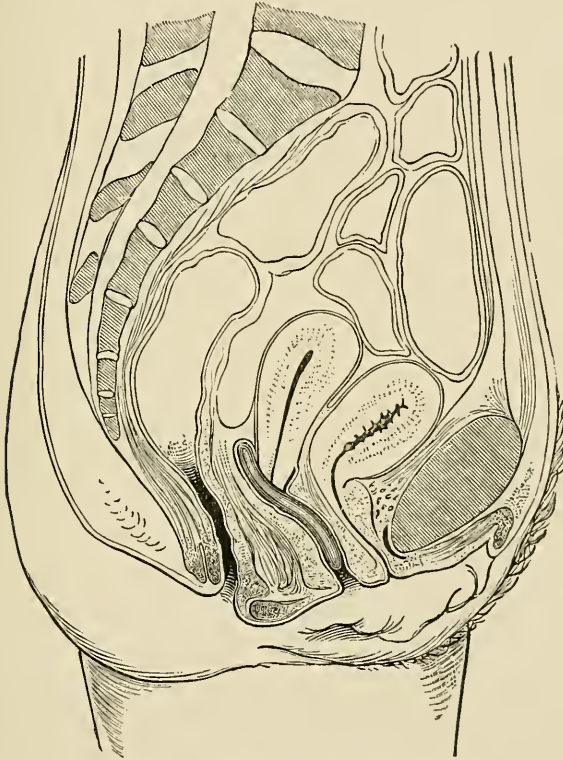

FIG. 119. — Hodge pessary in the vagina retaining the uterus *in situ*.

In a few cases it suffices thus to replace the uterus, and to place a pledget of cotton and glycerine in the anterior fornix, when the organ maintains its proper set. Usually, however, it returns sooner or later to its abnormal position; and in many cases the retrorsion is reproduced almost immediately on the withdrawal of the sound or of the replacing fingers. The next indication to be fulfilled, therefore, is the —

iii. *Maintenance in place.* — For this the application of a vaginal pessary in the form of a simple ring will sometimes suffice. Better still is the introduction of a Hodge pessary (Fig. 119), or Albert Smith's very

widely serviceable modification of the Hodge pessary. In some cases this pessary is borne with more comfort if the upper bar be thickened, as in the pessaries of Gaillard Thomas and Prochownik. Where the utero-sacral ligaments are greatly relaxed, Schultze's figure-of-eight pessary, or his sleigh pessary, may become necessary.

When we have to deal with retroflexions the vaginal pessary may be insufficient to retain the uterus in its place, and benefit is to be obtained by the cautious introduction of an intra-uterine stem. The Amann intra-uterine vulcanite stem, fixed on the edge of a disc, does good service in keeping the uterus straight; and when the anterior fornix is packed with iodoform gauze, or with pledgets of cotton or glycerine, the uterus is retained in position, and the walls recover their tone; when three or four periods have passed the organ may keep its place, or be kept in it, by the use of a vaginal pessary. Instead of a rigid stem of vulcanite a soft india-rubber stem pessary, which is more easily retained, may be passed into the uterus. The intra-uterine pessary sometimes has to be supported and supplemented by the use of the vaginal pessary; but care should be taken not to fix the two pessaries together in any such fashion as to interfere with the movements which the uterus must necessarily undergo in the changing relations of the pelvic viscera.

Where patients continue to suffer from the effects of retroversion or retroflexion of the uterus unrelieved by mechanical appliances and anti-phlogistic remedies, we must consider whether by some operative interference a cure may be effected. It has been proposed to fix the cervix uteri to the back wall of the vagina, but experiments made in this direction have not been encouraging. Better results have been obtained from shortening of the round ligaments. Where the uterus has acquired adhesions that cannot be relaxed or severed by bimanual manipulations the operation of laparotomy, which will allow of the freeing of the uterus and its subsequent ventro-fixation, becomes justifiable. Several operators have recently reported satisfactory results from a colpotomy which allows of the fundus uteri being reached through the anterior fornix and fixed anteriorly. The peritoneal cavity has even been opened into by the sacral method; and after the uterus has been freed from adhesions the fundus has been carried forwards, and the pouch of Douglas obliterated so as to prevent relapse of the displacement. Such procedures, however, should be reserved for cases where the retrorsion of the uterus is complicated with some other condition, such as displacement or disease of the ovaries, which aggravates the patient's distress, and forbids the relief that can ordinarily be afforded by properly adjusted pessaries. Some time must elapse before their ultimate results and their relative values can be ascertained, and no conscientious practitioner would subject a patient to an operation extending to the peritoneal cavity without explaining to her the dangers to which she will be exposed.

II. ANTERIOR DEVIATIONS. — At one time many of the cases of dysmenorrhœa and sterility that came under observation were supposed to



be cases of anteversion, or more frequently of anteflexion of the uterus; and were maltreated as such. But since gynæcologists have recognised that, with the bladder empty, the uterus is normally in a position of combined anteversion and anteflexion, they have been less disposed to look to these antrorsions for an explanation of the sufferings of their patients. Some would even eliminate the anterior displacements altogether from the category of uterine disorders, and only admit the existence of a pathological anteversion or anteflexion when they can lay their finger on the condition that causes or keeps up the dislocation. But, however freely we admit that the sufferings associated with these displacements are traceable to the causes that bring them about, or to the complications that attend them, there remains a residuum of cases in which the practitioner finds that he cannot effect a cure of his patient's condition without having regard to the displacement, and using means to correct it. As in the posterior deviations, so here the entire uterus may be rigid and rotated on its transverse axis, giving the condition of anteversion; or the body may be bent more or less acutely on the cervix in the state of anteflexion.

**Causes and Complications of Antrorsions.** — i. *Congenital.* — In early life the normal anteflexion of the uterus is very pronounced, and it is at the period of puberty that the body of the organ develops more decidedly, and tends to become more erect; then the congestion of each menstrual epoch is attended with a distinct straightening of the utero-cervical canal. In some patients, however, such erection of the organ fails to occur; and though for a time menstruation may go on painlessly, it is apt, in course of some months, to be attended with suffering. The uterus in such cases sometimes presents some other deformity, such as elongation of the cervix, or stenosis of the os; or it is attached to a vagina with unusually short walls.

ii. *Changes in the uterus.* — Inflammatory changes in the uterus may lead to an induration of the walls that gives a proclivity to anteversion, or to relaxation or atrophy of the tissues at the isthmus which will favour exaggeration of the normal anteflexion. But by far the greatest number of women who have pathological anteflexion of the uterus have also —

iii. *Changes in the ligaments.* — It is in inflammatory contractions of the utero-sacral ligaments that we so frequently find the explanation of this distortion of the uterus. As they lay hold of the isthmus these ligaments, when they become shortened, drag the cervix uteri towards the hollow of the sacrum; and, as the body of the uterus retains its mobility, it becomes bent in an exaggerated degree by the pressure of the superincumbent structures: the organ as a whole loses its power of adapting itself to the movements of the adjacent organs. The same effect is sometimes produced when adhesions have formed in the pouch of Douglas which fix the cervix to the rectum but leave the fundus free to become permanently anteflexed.

iv. *Directly displacing influences.* — Whilst increased weight or relaxation of texture of the uterus, and abnormal shortenings of its posterior ligaments, favour the occurrence of the anterior deviations, they are directly

produced by pressure bearing on the posterior surface of the organ. The ordinary intra-abdominal pressure may of itself produce the result under favourable conditions; but in some patients there is further pressure from the presence of tumours, or even from habitual constipation. In some very rare instances the uterus is fixed forward, as the result of inflammatory adhesions that have formed between the fundus and the bladder or anterior abdominal wall.

The causes that bring about the displacement very commonly remain, to some extent, as complications of the mischief; and they have to be carefully kept in view in the treatment of every case: moreover, as many of these patients become the subjects of salpingitis and oophoritis as well, the possibility of these complications being present must never be forgotten.

The **symptoms** that chiefly attract attention here are dysmenorrhœa and sterility. The patients may also have leucorrhœa, or trouble with the bladder or bowels, or be the subjects of pelvic and other pains; but, for the most part, they come under observation as young unmarried women suffering from dysmenorrhœa, or as young married women who have never conceived, and are perhaps also dysmenorrhœic. The menstrual pain is often due to the chronic utero-sacral cellulitis or other conditions causing the displacement; sometimes it is due to the stenosis that complicates it; sometimes it is to be referred to the endometritis that may in one patient be the cause of the ante flexion, and in another the consequence of it. There are yet others where the flexion leads to suffering because of the obstacle to the easy outflow of the menstrual fluid from a uterus that has lost its erectile property. As regards the sterility, we note that, whilst we find retroversion in a large proportion of the women who have given birth to one or more children, and then have acquired sterility, a greater number of those who are absolutely sterile, and have never conceived at all, are the subjects of ante flexion of the uterus. As with the dysmenorrhœa, so the sterility may sometimes find its explanation in the concomitant conditions; but, when these have all been combated, there remains a group of cases where the patient does not conceive until means are used to correct the displacement.

The **diagnosis** is made by bimanual exploration, which enables us to make out the size, direction, and relations of the uterus. The posterior parametritis or perimetritis that may have been the prime factor in bringing about the ante flexion is very likely to have produced at the same time some degree of retroposition of the organ, so that an imperfect exploration may lead to the diagnosis of a retroversion. Even with the greatest care it is in some patients difficult to make out the exact position of the fundus, unless the abdominal walls are thin, or the muscles are relaxed under chloroform. The sound is often helpful in determining the direction of the fundus. To facilitate its introduction it may have to be bent pretty sharply towards the point; but the most important matter to attend to in employing it in these cases is to avoid force in passing it onwards. When the point meets with resistance at the flexure, the

handle should simply be pressed backwards towards the perineum, when the finger in the anterior fornix will feel the body of the uterus settle down over the end of the instrument, and the diagnosis is made sure.

The **treatment** must have regard, in the first instance, to the various conditions that may be found causing or complicating the displacement. Until the hypertrophied uterus is reduced in size, its tense ligaments relaxed, and the inflammatory processes in and around it subdued by the use of douches, vaginal plugs, medicated pessaries and the like, it will be vain to attempt to relieve the patient's symptoms by mechanical measures calculated to correct the uterine displacement. For some gynaecologists the treatment of pathological antelexion would simply resolve itself into the treatment of uterine or pelvic inflammations. But it is to be remembered that the resorption of inflammatory deposits may sometimes be favoured by the appliances that have, at the same time, the effect of improving the position of the uterus; and if symptoms remain unrelieved by other measures, there is a clear indication for their employment. It has been found time after time that an intra-uterine stem pessary has promoted the disappearance of the endometritis which attends antelexion; dysmenorrhœic patients have menstruated without suffering; the uterus was thus kept straight, and women previously sterile have conceived with the stem in the uterus. It must be borne in mind that with any active inflammation in or around the uterus the employment of stem pessaries is a source of danger, whether in the posterior or in the anterior displacements. The instruments used should be carefully sterilised and applied with antiseptic precautions. When the intra-uterine stem is to be worn for some time it is usually necessary to introduce vaginal plugs below it, or to apply a vaginal pessary. In cases of anteversion a vaginal ring or a figure-of-eight pessary is often of use in relieving some of the pressure symptoms.

Operative measures of various kinds, such as the fixation of the cervix to the anterior wall of the vagina in cases of anteversion, and opening the pouch of Douglas to allow of removal of wedge-shaped pieces from the back of the uterus in cases of antelexion, have been proposed and carried out. But though the operators have given favourable reports of their cases, the operative treatment of the anterior displacements of the uterus does not offer much prospect of triumph for plastic surgery.

III. LATERAL DEVIATIONS. — Lateral deviations of the uterus are occasionally met with in practice; there may be dextroversion or dextroflexion when the uterus is turned or bent towards the right, or sinistroversion or sinistroflexion when the deviation is towards the left side of the pelvis. These variations are usually found, however, as subsidiary phenomena in association with inflammations, hæmatomas, or other tumours; or they may complicate the anterior or posterior displacements of the organ. Hence they are of relatively small clinical importance; they give rise to no distinctive symptoms; and their diagnosis and treatment are to be conducted according to the principles applicable to the detection and treatment of the more common deviations.



## REFERENCES

1. ALEXANDER. *The Treatment of Backward Displacements of the Uterus and of Prolapsus uteri.*—2. AMANN. "Ueber die mechanische Behandlung der Versionen und Flexionen des Uterus," *Archiv für Gynaekologie*, xii. 319. 1877.—3. ARAN. "Études anatomiques et anatomo-pathologiques sur la Statique de l'Utérus," *Archives générales de médecine*, i. 139 and 310. 1858.—4. ATTHILL. "On Retroflexion of the Uterus," *Dublin Quarterly Journal*, xlvii. 39. 1869.—5. BANDL. "Ueber die normale Lage und die normale Verhaltung des Uterus und die pathologisch-anatomischen Ursachen der Erscheinung Antelexion," *Archiv für Gynaekologie*, xxii. 6408. 1884.—6. BANTOCK. *On the Use and Abuse of Pessaries.* London, 1884.—7. BENNET. "On Antelexion of the Uterus considered as a normal anatomical Condition," *Dublin Quarterly Journal*, xxiv. 314. 1857.—8. BION. "Resultate der Ventrofixatio Uteri," *Inaugural Dissertation.* Bern, 1893.—9. BRAITHWAITE. "On a new Mode of treating certain Cases of Retroflexion of the Unimpregnated Uterus," *Transactions of the Obstetrical Society of London*, xix. 122. 1877.—10. MURDOCH CAMERON. "On Retroflexion of the Uterus," *Glasgow Medical Journal.* June 1877.—11. CAMPBELL. "Pneumatic Self-replacement in Dislocations of the Gravid and Non-gravid Uterus," *Transactions of the American Gynaecological Society*, i. 198. 1877.—12. DÜRRSEN. "Ueber Vaginofixatio Uteri," *Centralblatt für Gynaekologie*, xvii. 681. 1893.—13. EMMET. "A Study of the Causes and Treatment of Uterine Displacement," *American Journal of Obstetrics*, xx. 1040. 1857.—14. FEHLING. "Ueber die neueren operativen Bestrebungen zur Heilung schwerer Vorfällen," *Berliner klinische Wochenschrift*, No. 39. 1895.—15. FLAISCHLEN. "Zur Ventrofixatio Uteri," *Zeitschrift für Geburtshilfe und Gynaekologie*, xxx. 525. 1894.—16. GRAEFE, M. "Ueber die Behandlung (ins besondere die operative) der Rückwärtslagerung der Gebärmutter," *Volkmann's Sammlung*, No. 125. 1895.—17. GRAILY-HEWITT. *The Mechanical System of Uterine Pathology.* London, 1878.—18. HART, BERRY. *The Structural Anatomy of the Female Pelvic Floor.* Edinburgh, 1881.—19. HERMANN. "Contribution to the Anatomy of the Pelvic Floor," *Transactions of the Obstetrical Society of London*, xxxi. 263. 1889.—20. HILDEBRANDT. "Ueber Retroflexion des Uterus," *Volkmann's Sammlung*, No. 5. 1870.—21. HUGUIER. *Mémoire sur les Allongements Hypertrophiques du Col de l'Utérus.* Paris, 1860.—22. KÜSTNER. "Die Behandlung complicirter Retroflexionen und Prolapse besonders durch ventrale Operationen," *Volkmann's Sammlung*, No. 9; 1890: and "Eine einfache Methode, unter schwierigen Verhältnissen, den retroflectirten Uterus zu reponiren," *Centralblatt für Gynaekologie*, vi. 433. 1882.—23. LEOPOLD. "Ueber die Annäherung der retroflectirten aufgerichteten Uterus an der vorderen Bauchwand," *Volkmann's Sammlung*, No. 333. 1889.—24. MACKENRODT. "Die operative Behandlung der Retroflexio Uteri," *Deutsche medicinische Wochenschrift*, xviii. 491; 1892: and "Zur Technik der Vaginofixation," *Centralblatt für Gynaekologie*, xvii. 665. 1893.—25. MARTIN, A. "Ueber den Scheiden- und Gebärmutter-Vorfall," *Volkmann's Sammlung*, Nos. 183, 184; 1889: and "Die Colpotomie anterior," *Monatsschrift für Geburtshilfe und Gynaekologie*, ii. 109; 1895: and "Ueber die Combination der Exstirpation Uteri Vaginalis mit plastischen Operationen im Becken," *Berliner klinische Wochenschrift*, xxviii. 1085. 1891.—26. MARTIN, E. *Die Neigungen und Beugungen der Gebärmutter nach vorn und hinten.* Berlin, 1866.—27. MAYER, C. "Ueber Anteversio Uteri und ihre Behandlung mit Hilfe von Gummiringen," *Monatsschrift für Geburtshilfe*, xxi. 416. 1863.—28. NAPIER, LEITH. "On the Treatment of Uterine Prolapse," *Transactions of the Obstetrical Society of Edinburgh*, xii. 87. 1887.—29. NEUGEBAUER. "Zur Warnung beim Gebrauche von Scheidenpessarien," *Archiv für Gynaekologie*, xliii. 373. 1893.—30. OLSHAUSEN. "Ueber Ventrale Operation bei Prolapsus und Retroversio Uteri," *Centralblatt für Gynaekologie*, x. 698. 1886.—31. PANAS. "Recherches cliniques sur la Direction de l'Utérus chez la femme adulte," *Archives générales de médecine*, i. 274. 1869.—32. PROCHOWNICK. "Ueber Pessarien," *Volkmann's Sammlung*, No. 225. 1883.—33. ROUTH. "On the Use of Intra-Uterine Stems in Uterine Disease," *Transactions of the Obstetrical Society of London*, xv. 252. 1873.—34. SÄNGER. "Ueber Perineorrhaphie durch Spaltung des Septum Recto-vaginale und Lappenbildung," *Volkmann's Sammlung*, No. 301. 1888.—35. VON SCANZONI. "Ueber die Abtragung der vaginalen portion als Mittel zur Heilung des Gebärmuttervorfalls," *Berträge zur Geburtshilfe und Gynaekologie*, iv. 329. 1860.—36. SCHROEDER. "Ueber die fortlaufende Catginnahme bei plastischen Operationen," *Zeitschrift für Geburtshilfe und Gynaekologie*,



xii. 213. 1886.—37. SCHÜCKING. "Eine neue Methode der Radicalheilung der Retroflexio Uteri," *Centralblatt für Gynaekologie*, x. 181; 1888: and "Bemerkungen ueber die Methode der Vaginalen Fixation bei Retroflexio und Prolapsus Uteri," *Ibid.* xiv. 123. 1890.—38. SCHULTZE. *Die Pathologie und Therapie der Lageveränderungen der Gebärmutter*, Berlin. *The Pathology and Treatment of Displacements of the Uterus*, translated by J. J. and edited by A. V. Macan. London, 1888.—39. SIMPSON, J. Y. "Proposals for the Improvement and Elucidation of Uterine Diagnosis by means of a Sound or Bougie passed into the Uterine Cavity," *London and Edinburgh Monthly Journal of Medical Science*, iii. 701; 1843: and "On the Frequency, Diagnosis, and Treatment of Retroflexion or Retroversion of the Unimpregnated Uterus," *Dublin Quarterly Journal*, v. 371. 1848.—40. SINCLAIR. "Ventrofixation of the Uterus," *Medical Chronicle*, April 1894.—41. SKENE. "Injuries to the Pelvic Floor," *New York Medical Journal*, xli. 289, 317, 403, 457. 1885.—42. SMITH. "Ventrofixation and Alexander's Operation compared," *American Journal of Obstetrics*, xxxii. 264. 1895.—43. VAN DE WARKER. "Normal Position and Movements of the Unimpregnated Uterus," *American Journal of Obstetrics*, xi. 314 and 528. 1878.—44. VARNIER. "Des Cystoécèles vaginales, avec ou sans chute de l'Utérus, compliquées de Calculs," *Annales de Gynécologie*, xxiv. 201, 289, 366. 1885.—45. VEIT. "Klinische Untersuchungen ueber den Vorfall der Scheide und der Gebärmutter," *Zeitschrift für Geburtshilfe und Gynaekologie*, ii. 144. 1887.—46. WERTH. "Ueber die Anzeigen zur operativen Behandlung der Retroflexio uteri." *Separatdruck aus der Festschrift zur Feier des fünfzigjährigen Stiftungsfestes der Gesellschaft für Geburtshilfe und Gynaekologie zu Berlin*. 1894.—47. VON WINCKEL. *Die Behandlung der Flexionen des Uterus mit intra-uterinen Elevatoren*. Berlin, 1872.—48. WINTER. "Zur Technik der Ventrofixatio Uteri," *Centralblatt für Gynaekologie*, xvii. 625. 1893.—49. ZIEGENSPECK. "Ueber Thüre Braudt's Verfahren der Behandlung von Frauenleiden," *Volkmann's Sammlung*, Nos. 353, 354. 1890.

A. R. S.

## THE MORBID CONDITIONS OF THE FEMALE GENITAL ORGANS RESULTING FROM PARTURITION

### (LACERATIONS, FISTULAS, MORBID INVOLUTION)

#### THE TWO KINDS OF INJURY IN CHILD-BIRTH

MANY of the diseases to which women are liable arise from injury received in child-birth.

Two kinds of injury may occur: (1) The tissues may be mechanically damaged; (2) micro-organisms and poisons produced by them may get into the tissues. Either kind of injury may result in much after suffering; often both injuries are combined.

In the pages which follow I shall describe the mechanical injuries which may occur in child-birth, and the effects of them which may persist after child-birth is over. The diseases to which these injuries, by permitting the access of micro-organisms, may indirectly give rise, are described in other sections of this *System*.

The mechanical injuries are of two kinds: (A) tearing, and (B)

crushing. I shall first describe tearing; and I shall take first the part which is the first to be torn.

**MECHANICAL INJURIES — A. TEARING. — I. The Cervix Uteri.** — In some few labours the os uteri, solely by stretching, expands to a size large enough to let the child pass. But in most cases, as the force which is dilating the os increases as the size of the os increases, this force shortly before delivery becomes very great, and the enlargement of the os is finished, not by stretching, but by tearing. If the accoucheur add to the force by pulling with forceps before dilatation is complete, the tearing is generally greater than in deliveries left to nature. The tears, whether produced by unaided nature or by the forceps, are generally lateral. They may involve only the vaginal portion, or they may extend up to the os internum (see Fig. 122), down into the vagina, and outwards into the cellular tissue. They are often multiple, running in a stellate fashion from the os uteri; but if so, the lateral tears are usually the deepest. Big rents are said to be most frequent on the left side; but the preponderance is not great. Rents, great or small, are so frequent that their presence is a valuable presumptive evidence of antecedent child-birth.

As some persons think that these tears entail very important after-effects, the first practical question is whether anything can be done to prevent such effects?

*Should tears of the cervix be sewn up at once?*—Some writers have advised accoucheurs to sew up all tears of the cervix at once. This is difficult and troublesome. Moreover, as Freund has pointed out, these tears are irregular, and in the condition of parts after delivery it is difficult to follow them up. The accoucheur may think he has sewn up the whole of a tear when there remains a gap above or outside his line of suture which he has not perceived; and his stitches, by preventing free exit of discharge from such a spot, may favour retention and decomposition of discharge, and thus produce blood poisoning. In sewing up a deep rent it is possible to include the ureter in the stitches. During the involution of the uterus these tears heal to a large extent; I therefore agree with Freund, that the suture of lacerations of the cervix immediately after delivery is only desirable when required to stop bleeding.

*The results of cervical lacerations.* — Each tear of the cervix is an open wound. If during lying-in the genital organs are kept clean, and the lochia flow away properly, the wounds heal. The opposite surfaces of the tear may unite, and then no trace of it remains: but they seldom do, and the wound usually heals by granulation. Epithelium on one side develops from the mucous membrane of the vaginal surface of the cervix, on the other side from that of the cervical canal, and a fibrous scar is formed where they meet.

When the cervix surrounding the os externum has thus been made into two lips, with a gap between them, and the patient gets up, the intra-abdominal pressure drives the cervix uteri against the posterior

vaginal wall. This pressure forces the lips of the cervix asunder, and eversion of the lower part of the cervical canal is the result. By this eversion mucous membrane, which should not be exposed to any friction or pressure, is exposed to friction and pressure against the vagina. The effects of such friction and pressure are not the same in every case. In some, the part of the cervical canal exposed by eversion undergoes changes which make it like that of the vaginal portion; its columnar epithelium becomes changed into squamous, its rugæ become less prominent and may be effaced, and its colour becomes the same pale bluish pink as that of the vaginal portion. There is no inflammation of the cervix; its lips, although everted, are not thickened, and no symptoms arise. This change is more likely to happen if the involution of the uterus has gone on well.

In other cases, and especially in those in which there is subinvolution, the friction and pressure produce and keep up chronic inflammation of the cervix. Its lips become not only everted, but swollen; instead of their profile (on section) being conical, as in Fig. 120, it becomes club-shaped, as in Fig. 121. Its surface often becomes the seat of the adenomatous growth known as "erosion"—which name was

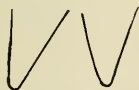

Fig. 120.—Profile on section of lacerated, but healthy, cervix uteri (diagrammatic).



Fig. 121.—Profile on section of lacerated and inflamed cervix uteri (diagrammatic).

applied to it before its histological structure was known. The growth, as its name implies, is one of gland tissue. The orifices of these newly formed glands often become blocked, the secretion is retained, and the gland becomes converted into a cyst containing a clear viscid fluid, a muco-purulent fluid, or pus. These cysts may remain after all other signs of adenomatous growth have disappeared.

The symptoms and treatment of the inflammation of the cervix thus produced or kept up by the eversion resulting from laceration are described in the section on Inflammatory Diseases of the Uterus.

**II. The Vagina.**—Considerable injuries to the vagina seldom occur during the spontaneous birth of a living child, or even when the delivery of such a child is skilfully helped with forceps; slight abrasions and shallow fissures, however, can be found after most first labours, if looked for, in the lower third of the vagina.

*Conditions favouring injuries to the vagina.*—But laceration of the vagina sometimes takes place even when the child is born without assistance. There are four conditions which make the vagina more than usually liable to be torn. These are (1) contraction of the vagina by fibrous tissue: either parametritic exudation which has become organised



into fibrous tissue, or scar tissue left after operations for vaginal fistulæ, rupture of the perineum, or the removal of vaginal cysts. (2) In the

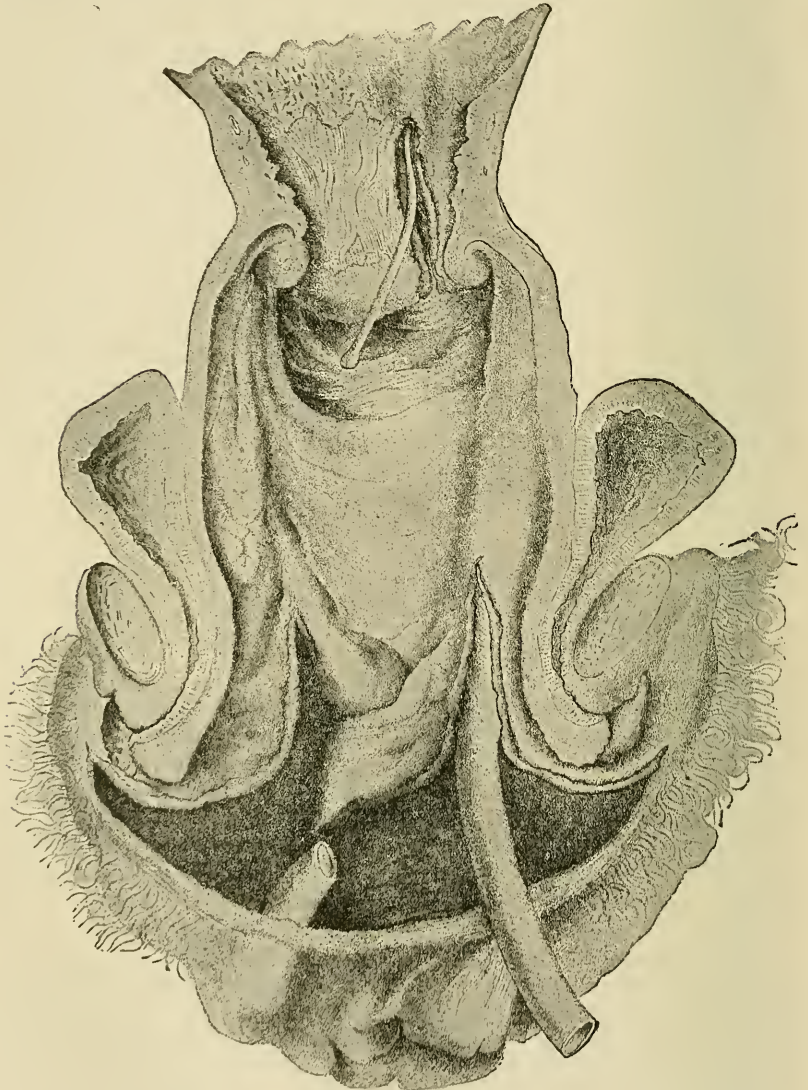

FIG. 122. — (After Freund.) Lacerations of cervix uteri and vagina. From nature. (The anterior part of the vagina, part of the bladder and pubic bones, have been removed, and a probe and drainage tubes inserted in the lacerations.)

older primiparæ the tissues stretch badly, and are therefore more likely to be torn. (3) Laceration of the vagina has been observed in cases of



difficult labour with small pelves, and it has been inferred that the tearing has happened because the vagina was small as well as the pelvis; but in such cases there is more than usual compression of the vagina between the head and the pelvis; moreover instrumental delivery is more often needed: these circumstances are to my mind a better explanation of the frequency of laceration of the vagina than a hypothetical smallness of the canal. (4) In some pelves the normal bony prominences are more pronounced than usual; among them the ischial spines. If this be the case, the vagina is especially liable to laceration where it is compressed between the foetal head and these bony points. Tearing of the vagina in natural labour is apt to occur when the pains are very strong and the head very large, so that the stretching of the vagina is great and comparatively sudden.

*Situation of vaginal tears.* — The vagina is narrowest at its lower part, but it is here thicker and stronger on account of the muscles and fasciæ inserted into it. The median raphe of the vagina is its thickest part. The posterior wall of the vagina is longer than the anterior, and is more stretched during labour; for it forms the outside of the curve along which the foetal head has to pass. Hence those tears that depend on rigidity of the tissues, or on large size and sudden expulsion of the head, are most often on the posterior wall and on one side, the side being that to which the face was turned during its passage through the pelvis (Fig. 122). The position of lacerations due to scar tissue, or to pressure upon prominent bony points, depends upon the situation of those structural peculiarities.

*Effects of displacement of the vagina.* — When the os uteri is fully dilated, and is drawn up over the head, the upper part of the vagina is pulled up. As the head is driven down, it presses the mucous membrane down before it. In these two ways the mucous membrane may be moved on the submucous tissue; it may either be pulled up or pushed down.

By such displacement of the vagina before the advancing head, the vagina is stretched from above downwards; and as tears by stretching are transverse to the line of greatest tension, tears running transversely to the long axis of the vagina and parallel to its orifice are thus produced. Tears of this kind are generally near the orifice: Duncan estimated their frequency in first labours at about 12 per cent. From this movement it follows that injuries of the vagina caused by pressure on bony points are not always exactly over these bony points, but sometimes above them, forming a sinus or pocket running downwards (Fig. 123). Another consequence is that in the displacement of the mucous membrane on the submucous tissue, vessels may be torn and blood effused in quantity varying from a few ecchymoses up to a quantity sufficient to form the swelling of the labium known as *thrombus*, or *haematoma* of the vulva.

*Effects of instrumental delivery.* — In the ways above described the vagina may be torn during natural delivery. But lacerations are more often produced directly, either by instruments, or by sharp edges or points of bone. Such tears may be deep, and extend into the bladder, ureter, rectum, or peritoneum. As a rule they imply unskilful mid-

wifery; either badly applied instruments, or pulling wrongly directed. But as the vagina is sometimes torn in natural delivery, it is clear that in the cases in which this is likely to happen, delivery in the most skilful manner with the most perfect instruments, cannot prevent the accident. A medical man is not, therefore, necessarily deserving of censure because the vagina was torn during instrumental delivery. Injury to the vagina is not an inevitable accompaniment of forceps delivery, but it is more likely to happen, and to be extensive, if delivery is hastened by forceps than if it is left to nature.



FIG. 123. — (After Freund.) Laceration of vagina forming a "pocket." A drainage tube has been placed in the "pocket." From nature.

*How forceps delivery produces lacerations.* — Forceps delivery adds to the risk of vaginal laceration in five ways. 1. The blades of the forceps increase by their thickness the measurement of the mass traversing the vagina; the vagina, therefore, is a little more stretched, though not much. 2. The forceps is used to hasten delivery; its use, therefore, generally implies that the vagina is less gradually stretched than when dilatation of the soft parts is left to the comparatively slow action of the natural forces. The rate of progress is an important factor in the production of vaginal lacerations. 3. Unless the forceps exactly follows every movement of the foetal head, its blades cannot always lie flat to the head; if they do not, then one edge of each blade will be raised off the foetal head. Although this projecting edge is not sharp, yet the vagina, where it is

pressed against this edge, is very tense, and may be cut; this is the main factor in the production of forceps lacerations. 4. The curve of the forceps is of greater radius than that of the head; hence the vaginal stretching is not only increased at the poles of the diameter of the foetal head at which the forceps blades lie, but is enforced over a larger surface. Moreover, as I have said, the head in forceps delivery is made to move on more quickly, and as the dilating agent advances down the vagina, that canal must either dilate or move on in front of it. From the increased volume and increased speed of the dilating body, it results that the displacement of the vaginal mucous membrane over the submucous tissues before the advancing mass, composed of the head in the grasp of the forceps, is more than that which is produced by the head alone. The bulging down of the vagina before the advancing forceps can be seen in any high forceps delivery. 5. When the head is delivered by artificial pulling the normal mechanism is interfered with; for the accoucheur cannot so exactly acquaint himself with the relations of the head and the pelvis as to pull in the precise direction and at the precise moment which will adapt the head to the pelvis in the most advantageous manner. There is often, therefore, a greater diameter of distension at a given place than in the normal process, and in this way the probability of vaginal laceration is increased. The advocates of the axis traction forceps claim that it lessens the risk of laceration of the vagina. With this instrument the lifting of the edge of the forceps blade off the head, and the interference with the natural mechanisms, are lessened; but I doubt if they are done away with. The other modes in which forceps delivery favours laceration of the vagina remain the same whatever the instrument used.

*Results of vaginal laceration.*—Tears of the vagina are important; firstly, because they may cause hæmorrhage after delivery. The treatment of such bleeding is a part of practical midwifery, and does not come within the scope of this article. Secondly, they make the patient more liable to puerperal illness; for every wound opens a gate for the direct entry of septic organisms. The presence of suppurating wounds in the vagina increases the amount of the lochial discharge, and as wounds of the vagina may form pockets (3), in which lochial discharge may be retained and decompose, any active microbes present in the passages will multiply in them. These microbes may so change the retained discharge that it becomes a chemical poison which produces fever (sapræmia); or in successive generations they may acquire fresh power, and produce septicæmia, phlebitis, and pyæmia; or again pelvic cellulitis.

Tears of the vagina may extend beyond the mucous membrane, and injure the fasciæ and muscles which form the pelvic floor. These structures may indeed be injured without laceration of the mucous membrane; or tears of the mucous membrane may heal, but the injury to the surrounding parts be imperfectly repaired. These injuries to the muscles and fasciæ will be next described.



**III. Injuries to the Muscles and Fasciæ of the Pelvic Floor.**— The fact that prolapse of the uterus is commoner in women who have had children than in virgins shows that this condition is favoured by child-bearing. It is certainly not due to lacerations of the vaginal mucous membrane, or of the perineum; for complete rupture of the perineum may exist unrepaired for years without prolapse. It is therefore a reasonable inference that child-bearing favours prolapse by causing injury to those structures in the pelvic floor which are the main supports of the uterus, namely, the pelvic fasciæ and the levator ani muscle. But our knowledge of these injuries has not advanced beyond opinion. I know of no dissection made to show the existence of the precise extent of such tears.

Schatz has described subcutaneous or rather submucous laceration of the muscles forming the pelvic floor (chiefly the levator ani) as occurring during labour. He inferred it by feeling, through the vagina, gaps between the muscular bundles, gaps which he assumed to be produced by the tearing through of other bundles which ought to have filled these spaces; but he has not verified this opinion by dissection. I have felt gaps between the muscular bundles such as Schatz describes, but I have failed to trace a subsequent tendency to prolapse in the patients in whom I detected them. Skene has also described subcutaneous or submucous laceration of the pelvic floor during delivery (presumably independently, for he does not refer to Schatz's paper, which was published about a year previously). He describes not only rupture, but fatty degeneration, atrophy, and paralysis of the torn muscular fibres; but he does not say that he has verified either the ruptures or the degeneration by dissection. He also describes a change in the position of the anus as a result of injury to the pelvic floor; but it does not appear from his paper that he has compared the state of the parts before child-bearing, in any particular case, with the state after it: without such a comparison it is not possible to be certain that what are described as changes due to injury in child-birth are changes at all. Kelly has described "relaxation" as "the most important of all injuries of the perineum and pelvic floor." His description of the injuries is based upon that of Schatz, but contains nothing to indicate that he has verified them by dissection. He says that as a result of these injuries the anal cleft is no longer a sharp, deep furrow, but is flat and shallow; and the anus is set farther back and more exposed. But without knowing in the individual cases what was the condition of the parts before child-birth, it is not possible to be sure that the peculiarities mentioned are really the result of injury. The depth of the anal cleft depends principally on the fatness of the buttocks, and the distance of the anus from the coccyx and pubes respectively is different in different women.

For the reasons given, I believe that the fasciæ and muscles of the pelvic floor are often injured in child-birth; and that such injury is the main cause of uterine displacements, notwithstanding that the fact has not yet been demonstrated by the exhibition of specimens. These displacements are described elsewhere in this *System*.



**IV. Rupture of the Perineum.** — Lacerations of the vagina are found out only by those who look for them. Injuries to the pelvic floor are a matter of inference, although their existence is almost certain. Rupture of the perineum has been known as long as midwifery has been practised.

*Tears of the vaginal orifice.*—As the fetal head emerges, its stress falls first upon the vaginal, and then upon the vulvar orifice; the vaginal orifice is marked by the hymen; the posterior part of the vulvar orifice, which is the part made tense, is the fourchette. The vaginal orifice is in the nullipara its narrowest part; consequently if any part of the vagina be torn, it is this. The vaginal orifice is always torn in first labours. Such tears are often multiple and stellate, radiating from the vaginal orifice; but whatever other lacerations may take place there is always one in the mesial line. Tears are more numerous on the left than on the right side. If the child is small the tear may be limited to the vaginal orifice, and not involve the fourchette.

*Tears of the perineum.*—Cases such as those just mentioned are the exception. In many first labours (according to Duncan in 60 per cent) the tear extends upwards through the mucous membrane of the vagina, backwards through the skin of the perineum, and through the tissues between them. This is rupture of the perineum. If the tear does not extend through the sphincter ani it is called “incomplete rupture.” During delivery the perineum is stretched both from side to side and from above downwards. The tension of its anterior edge is from side to side, and therefore rupture here occurs in a line perpendicular to that of greatest tension; that is, from before backwards. When the anterior edge is stretched till it can stretch no more it gives way, and the tear extends until by it the opening has been made large enough for the head to pass. The extent of the tear depends upon four factors; these are, (i.) the elasticity of the tissues; that is, the power of the tissue elements so rearrange themselves so that the part may elongate. Tears of the perineum are especially met with in elderly primiparæ, whose tissues are less elastic than those of the young: the difference dependent upon age is not great, but it exists. We know not what the structural peculiarities are which make one perineum more capable of stretching than another. (ii.) The length and situation of the perineum. The length of the perineum (5) in the nullipara varies from five-eighths of an inch to two inches. The situation of the fourchette varies from as much as two inches behind the lower border of the symphysis pubis, to close up to the symphysis. It is obvious that if the perineum be short and its anterior edge far back, less stretching will be required to let the child pass, than if the perineum be long and its anterior edge far forward. (iii.) The amount of stretching required, or in other words the size of the child. The birth of large children is oftener accompanied with rupture of the perineum than the birth of small children. Of children of average size the head is the largest part, and therefore that which tears the perineum. But in children of excessive size the trunk is larger in proportion to the head than in those of average size; therefore with very large children the

perineum is liable to be torn, or a small tear to be enlarged, during the passage of the shoulders. (iv.) The suddenness of the stretching. The more gradual the stretching of the perineum the less likely is rupture to occur. Rupture of the perineum is especially apt to happen in labours completed by very strong uterine action (such, for instance, as is provoked by ergot), in which case the child is propelled quickly through the genital canal; the same occurs in labours assisted with forceps if the child be too rapidly pulled through the vulvar orifice. It is not, however, a necessary consequence of forceps delivery; for this can be so managed as to give the perineum time to stretch. In labour protracted by weak pains, but ended naturally, rupture of the perineum seldom occurs.

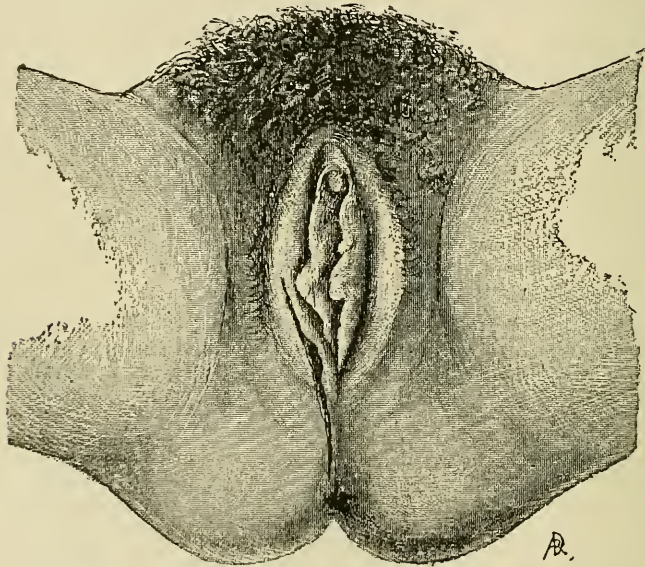

FIG. 124. — (After Ribemont-Dessaignes and Lepage.) Central rupture of perineum. From nature.

*Central rupture of the perineum.* — The common kind of rupture of the perineum is that which has been described above — a tear beginning at the tense anterior edge, and extending backwards. The tear generally begins in the middle line, but, owing to the vagina being thicker in the median raphe, an extensive tear seldom keeps the middle line.

There are less common ways in which rupture occurs. One way is called central rupture (Fig. 124): in this form the tear begins in the posterior wall of the vagina, above the orifice; then as the head is forced on, it presses into the tear in the vagina, widens it, presses asunder the muscular and fibrous structures of the perineal body, bulges down the skin in the middle of the perineum, and finally tears it. The tear, thus begun in the middle of the perineum, may extend forwards to the fourchette and

backwards to the anus — central rupture thus becoming complete rupture. Such I believe to be the common mode of production of central rupture of the perineum. But a tear of the vagina and cellular tissue of the perineum may not involve the skin of the perineum; the skin of the perineum may be centrally split without injury to the mucous membrane of the vagina; and the cellular tissue of the perineum may be torn without tear of either vaginal mucous membrane or perineal skin. The formation of a central perforation may begin in any one of these ways, the order of tearing being not always the same. Children have been born through central rupture of the perineum without injury to either anus or fourchette (10); although I think (with Madame Lachapelle and Matthews Duncan) that it is more common for delivery to take place through the vaginal orifice even in the presence of a central rupture.

*Rupture from above downwards.* — There is a still rarer mode of rupture of the perineum which I have once seen. The recto-vaginal septum was first torn through, and then this tear extended downwards through the perineum. After the head had been delivered the hand protruded through the anus, and then the shoulder came down, tearing the perineum from above downwards. Such a rupture must, of course, always be complete. This mode of rupture has also been reported by Baudry.

*Healing of perineal rupture.* — If left untreated, incomplete rupture of the perineum usually unites through part only of its extent, by the union of granulations on opposite sides; so that the perineum remains shorter than it was before. Complete rupture of the perineum occasionally heals without treatment; but this is an exceptional event.

*Results of rupture of perineum.* — Complete rupture of the perineum deprives the patient of the power of retaining fæces in the rectum. If a few fibres of the sphincter ani remain intact, so that its power is not destroyed, but only weakened, the patient may be able to retain scybala, but unable to retain fluid fæces.

Incomplete rupture of the perineum enlarges the vaginal orifice. The consciousness of being “more open” is sometimes disagreeable to the patient. If the patient suffer from descent of the uterus or vagina, for which the support of a pessary is desirable, the shortening of the perineum may make it difficult or impossible to get a vaginal pessary retained.

Neither complete nor incomplete rupture of perineum can cause prolapse of the uterus. I have seen a patient whose perineum had been ruptured twenty years before, in her first and only confinement, who had suffered since from inability to retain her fæces, yet she had not the slightest prolapse. But in the way above described rupture of the perineum much affects the success of the mechanical treatment of the prolapse. Central rupture of the perineum may heal incompletely, leaving a fistulous channel between the vagina and the perineum. Madame Lachapelle thought such fistula to be its usual consequence. That such fistulae are seldom now seen is a gratifying illustration of the progress of obstetric surgery.

*Treatment.* — There is only one treatment of rupture of the perineum,



and that is a plastic operation. The description of the operation is not within the scope of this article.

I come now to describe the injuries produced by crushing.

**MECHANICAL INJURIES — B. CRUSHING. — Vaginal Fistulas.** — Vaginal fistulas are among the most distressing consequences of mis-managed labour. There are three ways in which such fistulæ may be formed: (1) By tearing. The tears in the vagina which have been described in the foregoing pages may be so deep and extensive as to open the bladder or the rectum, and then, if healing be imperfect, a fistula is left. This is the usual way in which recto-vaginal fistula is formed, but it is a rare mode of production of vesical fistulæ. (2) By perforation, that is, by a sharp instrument or point of bone being thrust through the vagina into the bladder or rectum. This is a rare mode of origin of fistulas of any kind. Fistulas formed either by tearing or perforation have this feature in common, that the symptoms they cause appear immediately after delivery. (3) By sloughing. Nineteen out of twenty vesical fistulas are produced in this way. When so produced, symptoms do not appear immediately after delivery, but are postponed till after the separation of the slough. The sloughing comes of continuous compression of soft tissues between the fœtal head and the pelvic bones: such compression takes place when the membranes have ruptured, the amniotic fluid has drained away, the uterus has passed into a state of tonic contraction, and there is such a disproportion between the fœtal head and the pelvic brim or cavity that the head cannot enter the one or pass through the other. If the head cannot enter the brim, the uterine force is exerted in compressing the soft parts nipped between the head and the most prominent points of the pelvic brim. In the ordinary form of contracted pelvis the most prominent points are the sacral promontory and the pubic symphysis; the pressure effects are therefore greatest opposite those points. If the pressure be so great as to kill the nipped tissues, they slough. This sloughing is produced not by the magnitude of the pressure, but by its long continuance without intermission. The after-effects of the sloughing depend upon the situation of the damage.

*Crushing of tissues opposite sacral promontory.* — The vaginal wall, or the cervix uteri, may slough where there has been compression between the head and the sacral promontory, and such sloughing may open the pouch of Douglas. If the parts are preserved from septic infection the slough is separated, and Douglas' pouch is closed by adhesive inflammation. Such adhesions may alter the position of the uterus, and some physicians think that such changes in the position of the uterus produce anterior harmful effects. Information upon this point will be found in the article upon "Displacements of the Uterus."

*Crushing of tissues opposite the symphysis pubis.* — Sloughing in this situation is more important than in any other, because here it destroys the integrity of the urinary passages. The tissues which suffer most



are those nearest the head, that is, the posterior wall of the urinary canal; and therefore the result of such sloughing is incontinence of urine.

*Situations of urinary fistulas.* — The place at which the sloughing takes place depends upon the extent to which the os uteri had been dilated and pulled up over the head at the time pressure became continuous (Fig. 125). Sometimes, although very rarely, the membranes rupture early, and the os uteri dilates slowly, so that the amniotic fluid has drained off, and pressure has become continuous before the bladder has been pulled up out of the pelvis. In this case the slough may involve the cervix uteri and the ureter, a uretero-cervical fistula being formed. (These are often spoken of as “uretero-uterine fistulas,” but the sloughing affects the cervix, not

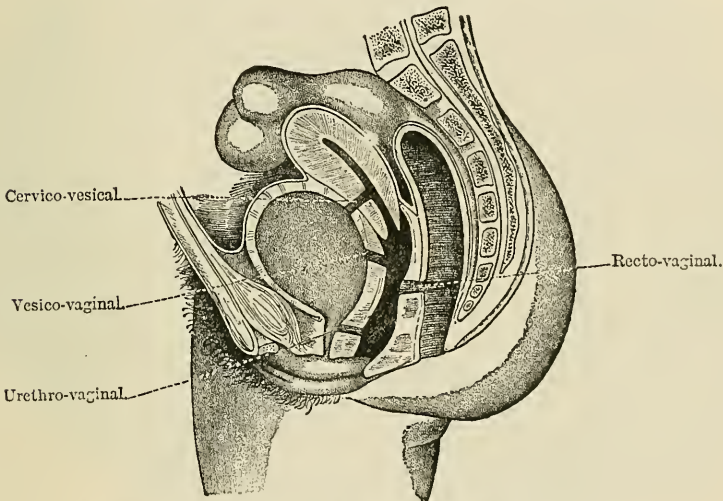

FIG. 125. — (After de Sinéty.) Diagram showing different kinds of fistula.

the body of the uterus.) One or both ureters may, in consequence of sloughing, come to open into the fistula. It must be admitted as possible that the tissues killed by pressure may comprise the ureters, and not the bladder; but the most probable explanation of such cases is that the slough involved cervix, ureters, and bladder wall; and that, while the urine was flowing away through the cervix, the gap in the bladder healed by granulation. No uretero-cervical fistula has yet been dissected after death. If there is a persistent hole in the bladder as well as the destruction of part of the ureters and cervix, the condition is called vesico-cervical (or incorrectly vesico-uterine) fistula. The destruction of tissue may involve a large part of the cervix uteri and the vagina; and this state is called vesico-cervico-vaginal (or vesico-utero-vaginal) fistula. Fistulas involving the cervix uteri are rare; according to Neugebauer they form about 8 per cent of the vesical fistulae which follow delivery:

fistulas involving the ureter are still rarer; they are rare, because pressure during delivery seldom becomes continuous until after the cervix uteri has been pulled up out of the pelvic cavity. When at this latter stage of the labour pressure becomes continuous, the bladder wall is killed at the part where it is in relation with the vagina, and a vesico-vaginal fistula is the injury which results.



FIG. 126. — (After Martin.) Annular sloughing of cervix uteri. From nature. Upper surface.

It is possible that during labour the relation of parts may alter, or be interfered with, so that after part of the cervix, ureters, and bladder have been so compressed as to kill the tissues, the cervix may be pulled up, and continuous pressure come to be exerted on the bladder; thus two fistulas, a vesico-cervical and a vesico-vaginal, are formed. The more probable explanation of the co-existence of two fistulas is that the sloughing at first produced one large gap, but that across this gap a bridge of tissue has subsequently united. Cervical fistulas according to Neugebauer are more common in multiparæ than in primiparæ.

*Annular sloughing.* — In cases in which the pelvis is contracted in all

its dimensions, or, being normal in shape and size, the child's head is too large, the head may enter the pelvic cavity and become impacted there; that is to say, stuck fast, unable either to advance or to recede. If this happen, a ring of soft tissue where the head is in contact with the pelvis will be crushed all round. If the impaction take place before the dilatation of the os uteri is complete, the cervix uteri may have its vascular supply cut off by the crushing of a ring of tissue above it, and may consequently slough. This sloughing may affect only a ring of cervical tissue, and, if

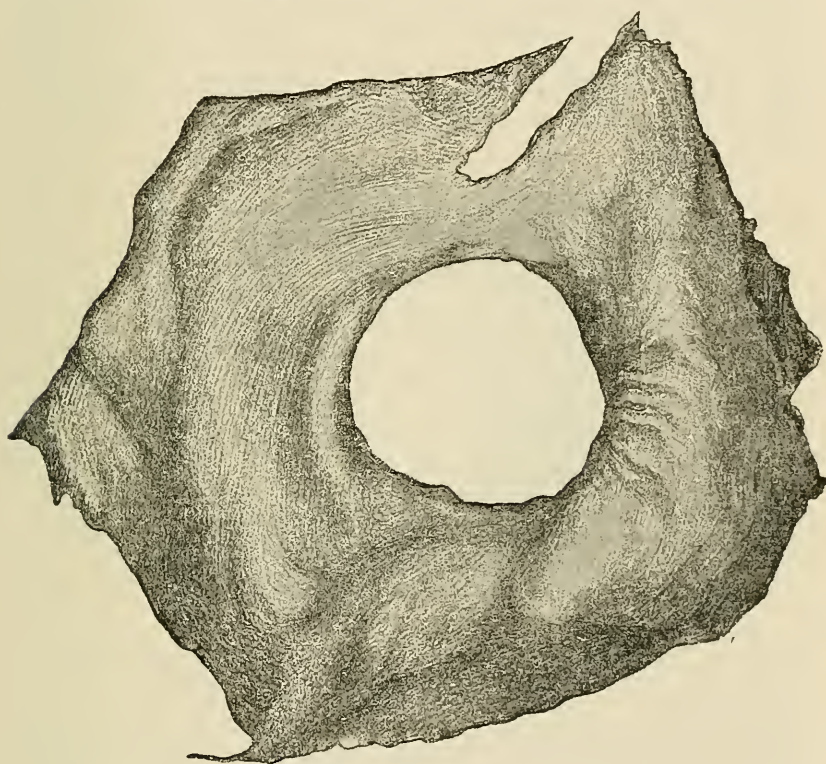

FIG. 127. — (After Martin.) Annular sloughing of cervix uteri. From nature. Lower surface.

so limited, the ill effects do not outlast the puerperium (Figs. 126 and 127). But the killing of tissue by pressure may affect more than the cervix: it may involve also the upper part of the vagina and the base of the bladder. When healing has taken place, so far as it may after separation of such a slough, the vagina is found converted into a short funnel ending in scar tissue bounding a hole not large enough to admit the finger. I have recorded a case in which such sloughing (5) took place in a woman who was not pregnant: in that case I was not able to find out its cause. The slough is preserved in the London Hospital Museum (Fig. 128)



(2123). I have seen a case in which sloughing took place after delivery, and the resulting condition was exactly the same as in the case above referred to; therefore, although the slough was not preserved, I do not doubt that the same parts were involved.

*Symptoms.* — The symptom of a vesical fistula, wherever situated and of whatever size, is incontinence of urine; that is, the patient's urine continually runs away through the vagina. The only exception to this is that when the fistula is small the pressure of the vaginal wall against it will sometimes temporarily close it while there is not much urine in the bladder, and the patient is recumbent. Hence these patients sometimes say that they can retain the urine for a time while lying down. The presence of a fistula is suggested, and may almost be affirmed by the urinous smell of the patient's clothing, before its discovery on

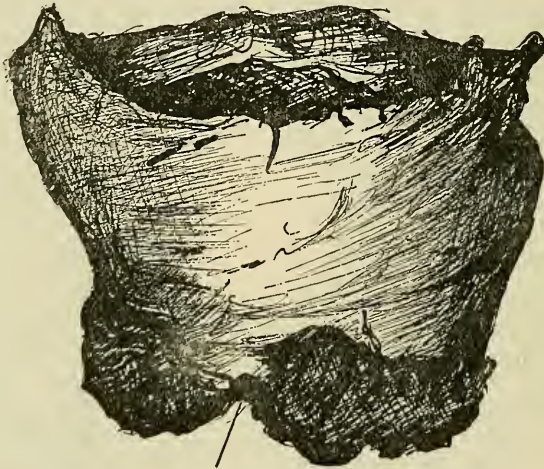

Os uteri externum.

FIG. 125. — Slough in one mass of cervix uteri, upper part of vagina, and base of bladder. From a specimen in the London Hospital Museum. No. 2123. Natural size. (Drawn by Dr. J. H. Sequeira.)

examination. Incontinence of urine is not the same thing as irritation of the bladder, that is, frequent micturition; although in both the patient may describe her trouble as inability to retain urine. When there is merely irritation the patient can generally empty the bladder often enough to prevent her clothing from being more than occasionally wetted; but when there is incontinence this is impossible, and unless special provision be made the clothes become saturated.

*History.* — When a fistula has been formed in the usual way — that is, by sloughing of the parts from pressure — there is no incontinence until the slough has at some part separated. Hence the history will be that the patient had a long labour, but no incontinence of urine till from five to ten days afterwards (which is the usual time for the separation of the slough), or even later; and that then the urine began to run away in-



voluntarily. If the fistula was produced by tearing or by perforation the incontinence of urine will date from delivery.

*Diagnosis.* — This can only be finally made by physical examination. Put the patient on her side, and expose the cervix and vagina with a duck-bill speculum; if there be a vaginal fistula the opening will be seen. Vaginal fistulas are often large; and then the mucous membrane of the opposite vesical wall often bulges through the fistula, forming a rugous swelling of deeper red and more velvety feel than the vaginal wall. Cervical fistulas are generally small; a cervical fistula big enough to admit the finger is exceptional.

If when the cervix and vagina are exposed a fistula cannot be seen, and yet there is no doubt that urine continually escapes by the vagina, put a catheter in the urethra and inject milk into the bladder. If there be a very small vaginal fistula the white, conspicuous jet of milk escaping through it will mark its place. If the fistula be cervical the milk will come back through the cervix uteri. If the fistula be uretero-cervical on one side, the history will be that the urine flows continually away by the vagina, while yet some urine is passed naturally; and when milk is injected into the bladder none will flow into the vagina. A cervical fistula involving both ureters is characterised by the flow of all the urine through a vagina which, on examination by injection of milk, shows no passage from the bladder to the vagina.

*Usual concomitants.* — With a fistulous opening into the bladder there is generally more or less severe cystitis, so that the urine is ammoniacal andropy. Injury, severe enough to cause sloughing of the bladder wall, often leads to sloughing at other parts of the genital canal, and to pelvic inflammation; hence there is often fixation of the parts by parametric exudation and by contraction of the vagina by scar tissue at other places. The irritation of the urine causes inflammation of the skin of the labia and thighs; and the mucous membrane and skin are often encrusted with earthy salts.

*Relation to operative delivery.* — When inquiry is made as to the labour after which a fistula has formed, it is found in most cases that some abnormal condition was present; and in many that operative delivery was required. Complications are frequent in such labours, because the disproportion which leads to continuous pressure also leads to disturbance of the mechanism of labour. There is no special complication other than disproportion, which produces sloughing and fistula as its consequence. The public are apt to think that the fistula was produced by the operative delivery, and it is true that in a few cases fistula is thus produced. In the great majority of cases, however, — those in which the fistula is produced by sloughing, — the fault lay not in the interference with natural delivery, but in the undue postponement of operative delivery. It is hardly necessary to point out, however, that delay in giving aid is not always the fault of the medical attendant.

*Treatment.* — The curative treatment of a urinary fistula is its closure by a plastic operation. The description of these operations is beyond

the scope of this article. [*Vide* art. "Plastic Gynæcological Operations."]

The palliative treatment consists in the constant use of some appliance to receive the urine. While the patient is about the choice lies between a urinal, and absorbent pads frequently changed. The latter is the least disagreeable. Wood wool is the best absorbent material. The pads must be thicker than is required for the menstrual discharge, and must be changed often. If the patient be so situated that she must go for hours without the opportunity of changing the pads, she must wear a urinal — an appliance which consists essentially of a trough to receive the urine, whence it is conducted by a narrow tube to a bag. There are practically only two kinds: one in which the trough is made rigid, so that it keeps its shape, though its pressure may be irksome; the other (known as the French model) in which the trough is made of thin flexible india-rubber: the latter is the less uncomfortable. At night discomfort is reduced to a minimum if the patient sleep on what is known as a "fracture bed" (that is, one with an opening in the middle for a pan), and is provided with plenty of absorbent material.

It is best to postpone operation until at least two months after delivery, and this for two reasons: firstly, the parts become less vascular and the tissues firmer after involution is complete, both of which changes are conducive to success in the operation; secondly, a vesical fistula, either cervical or vaginal, may spontaneously close. This is more likely to happen in the case of a cervical fistula, because such fistulas are small; but I have known a vaginal fistula, big enough to admit several fingers, to close completely without operation.

*Recto-vaginal fistula*, that is, an opening between the rectum and the vagina, is seldom produced by sloughing; because at the pelvic brim, the place where the tissues are most often nipped and made to slough, the rectum is at the side of the sacral promontory, and therefore out of the way of pressure. Such a fistula is generally the result of incomplete union of a bad rupture of the perineum, — the lower part of the rent heals, the upper does not. These fistulas are seldom large.

A recto-vaginal fistula permits the involuntary escape of fæces and flatus from the rectum into the vagina. They are curable by a plastic operation, and in no other way.

### MORBID INVOLUTION

**Subinvolution** means that the involution of the uterus after delivery has not been complete. To give a proper account of this, it is necessary first to describe briefly the normal process of involution.

*The involution of the uterus.* — On the day after delivery the uterus weighs from a pound and a half to two pounds and a half; and its fundus reaches as high as the umbilicus. Its return during the lying-in period nearly to the dimensions it had before pregnancy, is called "the involution of the uterus." Generally by the twelfth day after delivery the

fundus uteri is no longer above the pelvic brim. Two weeks after delivery the uterus weighs about half a pound; and three weeks after delivery from four to six ounces. Involution is in most cases complete at the end of two months, sometimes at the end of a month; but sometimes it takes as long as three months.

*How involution is effected.*—We have no exact knowledge of the changes which take place in the peritoneal covering of the uterus. It becomes smaller, and the wrinkles present in it after delivery are smoothed away; this is all we know. It is stated in most text-books that the muscular fibres of the pregnant uterus undergo fatty degeneration during the lying-in period and are thus removed, new ones being formed in their stead. The alleged fatty degeneration rests upon observations by Kölliker, supported by those of Luschka, Säger, and Mayor; but it has been denied by Robin. The opinion that the old muscular fibres are destroyed and new ones developed, was originated by Kilian in 1849. His statements were based on very few observations: most of them were on the uteri of women who had died from disease, and were made after decomposition had begun; moreover, at the time they were made histology was in its infancy. The subject has been more recently studied by Dr. T. A. Helme, with the advantage of modern histological methods. He observed the process in the rabbit, and examined many specimens immediately after death, and at all stages of the process of involution. His results far outweigh the few and imperfect observations quoted in support of the text-book account. Helme finds no fatty degeneration. There is atrophy, that is, diminution in volume of the muscular fibres. There is not, as in a pathological atrophy, degeneration of the muscular fibres and increase of connective tissue, but a shrinking of muscle and connective tissue alike—a physiological retrogression. The change is probably chemical, a sort of peptonisation which makes the contents of the muscle cells more soluble, so that they can pass into the lymph stream; but there is no fatty change. The atrophy goes on simultaneously and equally at all parts of the uterus alike; no groups of degenerated cells are found amidst healthy tissues. Helme has noticed two stages in the process: during the first thirty-six hours the muscular fibres, which at the end of pregnancy are remarkably translucent, become cloudy and rapidly diminish in volume; then a more gradual shrinking follows. Helme finds no evidence of a destruction of old fibres, or of a formation of new ones. The only change seems to be that large fibres become small. Broers has investigated the subject in the same way as Helme, and finds fatty degeneration. Helme tells me he thinks that the granules which Broers takes for fat globules are not such: in support of his opinion he points out that Broers found them in blood corpuscles, a place where fat globules would hardly be expected, and in the uterus during labour.

Observations are also discrepant as regards the changes in the connective tissue. Fatty degeneration, atrophy, development of new connective tissue, have each been described. Helme finds that the con-

nective tissue at first becomes granular, and then gradually diminishes and disappears.

During the last few days of pregnancy and the first few days of involution giant cells with many nuclei are to be seen: they are formed by the coalescence of single cells which are probably leucocytes. These giant cells are not seen after the sixth day of involution. Their function is probably to eat up the waste material lying about them — granules from connective tissue or matter in solution from muscle cells.

Structural changes take place also in the vessels. At the beginning of involution the veins are compressed by the contraction of the muscular bundles between which they lie: some of them become pervious again; in others, their endothelium comes to present a hyaline and granular appearance, and the vessel is gradually obliterated and disappears. In some of the veins there is a proliferation of the intima, so that the vessel wall becomes permanently thickened. In some of the arteries there is a hyaline and granular appearance of the coats: some become obliterated, but in the larger ones there is a true proliferative endarteritis, growth taking place both from the endothelium and from the sub-endothelial connective tissue. At the end of involution the connective tissue around the arteries is increased in quantity, the arterial muscular wall is greatly hypertrophied, and the inner wall considerably thickened. On section the arteries project beyond the surrounding surface, and present thick, yellowish white walls, more opaque than the tissues around. This state of the arteries was described by Sir J. Williams in 1882 (15). He holds that it affords "the strongest presumptive evidence of parity" that we possess.

In an ideal case involution should go on till the uterus is reduced to the same size as it was before pregnancy; this, however, seldom occurs. It is so common for involution to be not quite complete that in text-books of anatomy it is stated that the parous uterus is normally larger than the virgin uterus. When involution is thus incomplete the condition of the uterus is called "subinvolution." In a few cases the involution goes on to such a degree that the uterus becomes smaller than it was before pregnancy. This is called "superinvolution" or "puerperal atrophy of the uterus."

*The morbid anatomy of subinvolution.* — We know of no constant difference, except in size, between uteri which a few months after delivery still remain large, and those which have returned to the ordinary size of the unimpregnated uterus. General enlargement of the uterus with pelvic pain and other symptoms is known as "chronic metritis," and some writers have described subinvolution and chronic metritis as identical. General enlargement of the uterus persisting long after delivery was described by Klebs under the name of "diffuse hyperplasia of the uterine parenchyma." He says that in some cases hypertrophy of the muscular fibres is present; in others, hypertrophy of the connective tissue bundles. The more the latter are developed the firmer the tissue. He says that this hypertrophy has been regarded as a result of chronic



inflammation, and that in many cases inflammatory changes in the mucous membrane are unquestionably present; in many others, however, there is no clinical proof of inflammation having been present, the condition having developed itself without any symptoms [*vid. sect. on Fibrous Hyperplasia in Prof. Adami's art. on "Inflammation" in the System of Medicine, vol. i., and also Dr. Mott's art. in same volume*]. Both inflammatory and non-inflammatory forms have in common the enlargement of the uterus and increase in its blood-supply. Klob described chronic enlargement of the uterus as being due to a diffuse growth of connective tissue. He said that the uterus is at first congested and turgid, the connective tissue being immature; but that the longer the disease lasts the denser the fibrous tissue becomes, compressing and perhaps obliterating the vessels, and making the uterine tissue paler and harder. At the beginning of the process, according to Klob, the muscular fibres are hypertrophied; but later they are lost in the hypertrophy of the connective tissue. The uterus when so enlarged has all its diameters increased, but especially the antero-posterior measurement of the uterine body. The cervix is thickened. The uterine cavity is longer and broader, but its anterior and posterior walls are still almost in contact. Klob holds that the pathological change is not a result of inflammation, but a growth of connective tissue. Klob does not say how far his conclusions are based on the writings of others, and how far on specimens examined by himself; nor does he say how many specimens he has examined, or from what women obtained. Without some knowledge of the age, the time intervening since the last pregnancy, the cause of death, and the associated morbid conditions in the pelvis, it is impossible to decide how far the changes described by Klob are such as naturally occur in healthy women as they grow older, or how far they are morbid.

*The causes of subinvolution.*<sup>1</sup>—For perfect involution of the uterus to take place, it is necessary that during the lying-in period the patient should be healthy and the uterus contracted. The contractions of the uterus, by intermittently compressing the vessels, mechanically help the circulation both of blood and lymph through the organ. When the uterine contractions are imperfect, the more languid movement of the blood helps to make involution slow and incomplete. Therefore, after post-partum hæmorrhage—an accident which implies imperfect uterine contraction—subinvolution is apt to appear. Uterine contraction is especially imperfect when a bit of placenta or membrane is retained. The presence of what (in the lying-in period) is a foreign body in the uterus, not only interferes with uterine contractility, but mechanically prevents the shrinking of the organ. When fever arises all the bodily functions are badly performed, and the natural metabolism is altered; the uterus, like other tissues, then suffers, and its involution is retarded. This effect is especially marked when the cause of the fever is inflammation in the pelvis; for then the uterus not only suffers, in common with the rest of the

<sup>1</sup> For an analysis of what has been done on this subject and original observations, see References (16) and (11).

body, from the febrile disturbance of nutrition, but the local inflammatory disturbance affects its own circulation. Hence the most marked cases of subinvolution are those associated with pelvic inflammation. Again, when women have many children involution does not go on so fast, or take place so perfectly, as after their earlier labours.

Subinvolution has been attributed to certain other causes which must therefore be mentioned:—(a) “General debility”: this is so vague a term that it may include almost anything, and its effects can neither be proved nor disproved. (b) Parturition late in life: the effect of multiparity has been mentioned, and women who have had many children are generally elderly; but apart from multiparity, there is no evidence that the completeness of involution at all depends upon the patient’s age. (c) Premature delivery: there is no evidence that after premature labours free from complication subinvolution is more frequent than after labour at term. Premature labour, however, is often induced for or by conditions—such as placenta prævia or constitutional disease—which lead to fever, or to imperfect contraction of the uterus; for these reasons, and not because delivery was premature, subinvolution may be more frequent after premature deliveries. (d) Laceration of the perineum: when there is a large wound of the genital passage the patient is more likely to become febrile than when the mucous membrane is intact; for this reason subinvolution is more frequent when the perineum is badly torn than when it is not torn; but the event is due to the fever, not to the rent in the perineum. (e) Lactation: some authors have stated that nursing favours involution, others that it hinders it; no facts have been brought forward in support of either assertion; nor do we know the effect of lactation on involution. (f) Lacerations of the cervix uteri: these have no influence on involution. They are so high up that in a well-managed confinement pathogenetic microbes do not get access to them, and thus do not get the opportunity of causing fever. (g) Plural pregnancy: as the uterus is here bigger than usual, involution may be slower; but I know of no proof that it is so. (h) *Other alleged causes*: phthisis, diabetes, Bright’s disease, syphilis, chronic suppuration, pneumonia, bronchitis, emphysema, heart disease, rheumatism, mental disturbance, chorea, eclampsia, bad sanitation, retroversion of the uterus, have all been said to hinder involution; but I have not found a particle of evidence to prove this effect of any one of them. They may or they may not cause subinvolution; we have no knowledge on the subject.

*Effects of subinvolution.*—Subinvolution in itself produces no disturbance of health. The uterus is often found large, but otherwise normal, in women who have had many children, and are quite well, but in whom examination was made because some disease was suspected.

A tissue that is in any way degenerated is more vulnerable under adverse influences than one which is healthy. Emphysematous lungs are more liable to bronchitis than healthy ones. A woman who has often suffered from the œdema common in pregnancy, is more likely to get her feet swollen from fatigue than one whose feet have never been

oedematous. A uterus not well involuted is more liable to disturbances of its circulation, and to the morbid changes resulting therefrom, than a healthy uterus. The diseases to which subinvolution makes the patient more liable than she was before are described in other parts of this *System*.

*Subinvolution of the vagina.* — During pregnancy the vagina develops as well as the uterus; its vessels increase in number and size, it becomes larger, and its wall is thicker and softer. These changes obviously fit it for dilatation during child-birth. After delivery it undergoes involution; it becomes less vascular, its capacity less, its mucous membrane firmer and thinner. So far as I know the minute anatomy of these changes has not yet been studied. In women who have had many children the involution of the vagina is often incomplete; the canal remains larger, its mucous membrane thicker, its rugæ larger. This subinvolution renders it more liable to catarrh, and women who have had children, especially those in whom the vagina is large and relaxed, are, therefore, more subject to leucorrhœa than virgins.

*Treatment of subinvolution.* A. *Preventive.* — In the management of child-birth subinvolution is to be prevented (*a*) by taking care that no part of the placenta or the membranes is left behind in the uterus; (*b*) by the daily administration of ergot for three or four weeks after delivery. This drug has no effect upon normal involution; if, therefore, it is certain that everything is taking a normal course, the drug is unnecessary. But when any adverse condition prevents proper contraction of the uterus, ergot will hasten involution by making the uterus contract.<sup>1</sup> (*c*) By not allowing the patient to get about too soon. (*d*) I think, though I cannot adduce evidence in support of my opinion, that the use of astringent antiseptic douches during the lying-in period promotes involution of the vagina.

B. *Curative.* — When the puerperal state is over, and involution still incomplete, no treatment will make the uterus get smaller. One event, and one only, will alter the state of the uterus; that is, another pregnancy. If the patient become pregnant, the uterus in the succeeding puerperium, if no contrary cause again hinder involution, may fall quite to its natural size, or even below it.

**Superinvolution of the Uterus.** — What is superinvolution? The word means that the uterine involution does not stop at the restoration of the uterus to its former size, but goes beyond this point, and leads to permanent diminution of the size of the organ and arrest of its functional activity. The ill-formed word "superinvolution" was introduced by Sir James Simpson; but the disease had been previously described under the

<sup>1</sup> In a paper by Dr. C. Owen Fowler and the author (*Obst. Trans.*, vol. xxx.), evidence is published that in a series of unselected cases in which ergot was given, involution was less often delayed than in a series in which ergot was not given. The late Dr. Blanc, of Lyons, about the same time published a paper (see *Lancet*, 1892 v. 2. p. 1160), in which he compared two sets of cases, one with and one without ergot, and found that there was no difference in the rate of involution. But Dr. Blanc excluded all abnormal cases from his observations: his results are therefore in harmony with the view stated in the text.



better name by which it is still known in Germany, namely, "puerperal atrophy of the uterus." This term at once denotes its nature and its pathological alliance with atrophy of the uterus occurring in other circumstances.

*Morbid anatomy.* — German writers speak of "excentric" and "concentric" atrophy. Excentric atrophy means that the cavity of the uterus retains its natural dimensions, but that the wall of the organ is thinned, so that its external measurements are smaller. Concentric atrophy means that besides the wasting of its wall, the uterine cavity is diminished in length and breadth. It is reasonably believed that excentric atrophy is an early stage of concentric atrophy. It is easy to recognize concentric atrophy; but in the case of excentric atrophy it is difficult to say what degree of thinning of the uterine wall should be regarded as pathological, and very difficult to be certain of the existence of slight thinning. Hence statements about uterine atrophy, based on the supposition of excentric atrophy, are to receive only a provisional acceptance. It is said by German authors that some excentric atrophy takes place naturally during lactation; and that after weaning the uterus returns to its normal thickness. It is difficult to be sure of this, for we have no means, in the living subject, of measuring the thickness of the uterine wall; the fact of thinning rests only upon the impression of slightly diminished size gained by bimanual examination. Judging as well as I can in this imperfect way, I am disposed to think that the German observers are correct. In superinvolution this normal atrophy of lactation goes on to a higher degree, and is permanent.

When atrophy has advanced to the degree denoted by the word "superinvolution," the uterus is smaller in all its dimensions, and its wall is thinner; its mucous membrane is either absent or very thin; its muscular tissue is thinned, the fibres are closely packed, and among its fibres thrombosed and obliterated vessels are to be seen.

*Etiology.* — Certain puerperal diseases are followed by atrophy of the uterus. These are (*a*) any puerperal illness leading to cachexia, that is, to wasting and anæmia; (*b*) suppuration of the ovaries leading to their destruction; (*c*) pelvic cellulitis leading to a fibrous induration which, constricting the vessels, cuts off part of the uterine blood-supply; (*d*) inflammation of such severity as to lead to sloughing of the inner part of the uterine wall — the so-called "endometritis disseicans." These diseases are rare, and recovery from them is rarer still. Puerperal atrophy of the uterus is also an unusual disease. Hence the relation between these rare conditions is supported by a very few observations. We know not what are the morbid changes in the ovaries, if any, upon which superinvolution depends.

There are also diseases which may lead to amenorrhœa and atrophy of the uterus, apart from the puerperal state; it seems a reasonable inference, therefore, that if they occurred in pregnancy they would lead to atrophy of the uterus during the puerperium: but their influence in this way is but a probability, not a fact verified by observation. Among



them are phthisis, diabetes, Addison's disease, Graves' disease, myxœdema, insanity, emotional shock, paraplegia.

The foregoing are possible causes. The disease is so rare that no series of cases large enough to place the ordinary causation of superinvolution beyond dispute has yet been published. It is certain that superinvolution sometimes occurs in women in whom not one of the causes assigned for it (and enumerated above) has been present, and in whom examination reveals no other departure from the normal than that the uterus has undergone atrophy.

*Symptoms.*—The only invariable symptom is amenorrhœa. Sterility is probably a consequence, but as the essential condition for fertility in the female is not the state of the uterus, but the production of healthy ova (as shown by the occurrence of pregnancy in a rudimentary uterine cornu), it cannot be asserted that superinvolution directly or necessarily causes sterility. Superinvolution probably, indeed, depends on ovarian atrophy; but, as I have stated above, no morbid changes in the ovaries associated with superinvolution have yet been demonstrated.

As the climacteric is really produced by superinvolution, the changes and symptoms usual at the climacteric gradually supervene. The breasts waste, and the patients complain of the chills, flushes, and sweats which usually trouble women at the menopause. The only other symptoms that I have seen associated with superinvolution are frequent headaches and leucorrhœa. Sir James Simpson says that superinvolution is associated with "constitutional ill health," "general debility," "depression and impaired activity of mind." This is no doubt true, but it is difficult to disentangle cause and effect, and to be sure whether superinvolution is the cause of ill health, or the ill health the cause of the superinvolution. In my judgment the latter view is the true one; I do not think that any symptoms belong to superinvolution except amenorrhœa, sterility, and the usual climacteric disturbances.

*Diagnosis of superinvolution of the uterus.*—The diagnosis is suggested by the history, which is that of amenorrhœa dating from the birth of a child and continuing, although the patient has long ceased to suckle. It is made certain by finding out by physical examination the smallness of the uterus. This is done in three ways:—(a) By passing the sound. In this way the length of the uterine cavity can be accurately measured. A fallacy attends it, namely, that the sound may not have passed the whole length of the canal: therefore it needs to be supplemented by methods of determining the size as well as the length of the uterus. Of these the best is (b) bimanual examination, which means grasping the uterus between a finger in the vagina and a hand on the abdomen. Thus its size can be well estimated. If this cannot be done—either because from nervousness the patient keeps the abdominal walls very hard, or because she is very fat—then use method (c). Seize the cervix with a hook or volsella (the volsella gives the securer hold, but hurts the patient more), and pull it down towards the vulva. Then insert a finger into the rectum, and you will feel the whole length and breadth of the

posterior surface of the uterus. The smallness of the uterus thus ascertained establishes the diagnosis of puerperal atrophy.

*Treatment of superinvolution.*—The only method of treatment which is unquestionably beneficial is the cure, if possible, of any condition of ill health which may be the cause of the uterine atrophy. The modes of treating the different causes of anæmia and wasting are described in the medical sections of this system.

If the patient be florid, and the time at which menstruation should occur is marked by uncomfortable sensations, these symptoms may be relieved, and the uterus stimulated by the application of leeches to the cervix uteri. Cases of this kind are rare.

Electricity has been recommended. The only kind of electricity likely to be effective is the passage of a current through the organ between an electrode applied to the uterus, and one on the abdominal wall; I know of no evidence, however, that such treatment has proved useful.

Stem pessaries, whether of glass, metal, or vulcanite, have been used. Sir James Simpson recommended a "galvanic stem," that is, an intra-uterine pessary made half of zinc and half of copper, the two halves lying side by side. When this is put into the uterus, the secretions of the part set up galvanic action between the zinc and the copper, and chloride of zinc is formed, which, being a caustic, inflames the mucous membrane with which it comes in contact. This is an injurious action. I know of no evidence that the galvanic stem does any good. But any intra-uterine stem, however unirritating the material, may produce peritonitis; and I know of no evidence that such stems will make a uterus which has undergone superinvolution again develop itself. If intra-uterine stems of any kind are to be employed it should only be after explanation to the patient that the instrument is not likely to do good, and involves some risk to life. If the patient be rightly informed of the small prospect of benefit from local treatment, the dangers involved in it, and the unimportance of the effect of superinvolution upon health and duration of life, she will generally prefer to let it alone.

It is to my mind very doubtful whether any treatment will make a uterus, which has fallen into atrophy, again develop itself. In most cases in which the uterus is small because it never has developed treatment is a failure; and the prospect when the uterus has normally developed, has been functionally active, and then has wasted prematurely, is far less hopeful.

G. ERNEST HERMAN.

#### REFERENCES

1. BAUDRY. *Annales de Gynecologie*, Juillet 1894.
2. BROERS. *Virchow's Archiv*, Bd. cxli. July 1895.
3. DUNCAN, MATTHEWS. *Obstet. Trans.* vol. xxxi.
4. HELME, T. A. *Trans. Royal Society Ed.* vol. xxxv. Part 11, No. 8.
5. HERMAN, G. ERNEST. *Obstet. Trans.* vols. xxix. xxxi.
6. KELLY. *American System of Gynecology and Obstetrics*, art. "Injuries and Lacerations of the Perineum and Pelvic Floor."
7. KLEES. *Handbuch der pathologische Anatomie*, p. 879.
8. KLOB. *Pathological*

*Anatomy of the Female Sexual Organs*, translated by Kammerer and Dawson, 1868, p. 127.—9. NEUGEBAUER. *Arch. für Gyn.* Bd. xxxiv.—10. RAMSBOTHAM, F. H. *Obstet. Med. and Surgery*.—11. RIES. *Zeit. für Geb. und Gyn.* Bd. xxiv.—12. SCHATZ. *Arch. für Gyn.* Bd. xxii. 1884, S. 298.—13. SIMPSON, Sir JAMES. *Works*, vol. iii. p. 602.—14. SKENE. *New York Med. Journal*, March 14, 1885.—15. WILLIAMS, Sir J. *Obstet. Trans.* vol. xx.—16. WILLIAMS, Sir J. *Brit. Med. Jour.* 1882, vol. ii. See also, on Rupture of Perineum, DUNCAN, MATTHEWS. Papers on the Female Perineum, and on Methods Proposed to Prevent it, MERKERTTSCHIANTZ, *Arch. für Gyn.* Bd. xxvi., and LEISHMAN, *Glasgow Medical Journal*, 1860. On Lacerations of Vagina, FREUND, *Gynäkolog. Klinik*. On Puerperal Atrophy of Uterus, THORN, *Zeit. für Geb. und Gyn.* Bd. xvi.; FROMMEL, *Zeit. für Geb. und Gyn.* Bd. vii.; RIES, *Zeit. für Geb. und Gyn.* Bd. xxvii.; GOTTSCHALK, Volkmann's *Vortrage*, N. F. 49.

G. E. H.

---

## EXTRA-UTERINE GESTATION

NORMAL pregnancy, or the state of "being with young," is the outcome of two factors—i. Impregnation. ii. The retention of an oosperm in the cavity of the uterus.

In order to reach the uterine cavity the ovum must traverse the Fallopian tube. When an oosperm (fertilised ovum) is retained in the tube it continues to develop, and gives rise to the condition known as tubal pregnancy.

The causes of tubal pregnancy are unknown; and our ignorance will continue until we have some trustworthy information concerning the situation in the genital passages where ovum and spermatozoon normally meet. It is probable that fertilisation normally happens in the uterus, and that when it occurs in the tube it is accidental, and tubal gestation the consequence.

Obstruction to the transit of ova will not explain matters, for an oosperm is more often retained in the wide ampullary section of the tube than in its uterine segment. My own observations teach me that tubal pregnancy is the result of active rather than of obstructive causes. The union of a spermatozoon with the nucleus of an ovum not merely initiates, in the previously passive cell, most marvellous and rapid changes ending, under favourable conditions, in the production of a new individual; but in some unknown way exerts also an extraordinary influence on the reproductive organs. Hence it is probable that when an ovum is fertilised, the resulting oosperm engrafts itself at once on the adjacent mucous membrane, whether tubal or uterine.

Tubal pregnancy may happen as a first pregnancy in women who have been married eight, ten, or even twenty years. A woman, thirty-seven years of age, from whom I removed a gravid tube five weeks after primary rupture, had been twice married, and her matrimonial life had extended over seventeen years; yet her first pregnancy was tubal. Tubal

pregnancy may follow normal gestation, or an abortion, within a few months; or it may occur as a first pregnancy in a woman of twenty or forty years. A Fallopian tube may become gravid in the newly married, or in the mother of a large family. *Both tubes may*, in very exceptional instances, *be gravid concurrently*; or one tube may become pregnant years after its fellow. In very rare cases two oosperms are retained in the same Fallopian tube—*twin tubal pregnancy*; or again, *tubal may complicate uterine pregnancy*. An analysis of a large number of cases establishes the fact that the occurrence of tubal pregnancy is often preceded by a long interval of sterility. As this last statement is often used in an uncertain manner, it will be useful to attach some definite meaning to it.

Matthews Duncan, from a careful consideration of 3722 cases of delivery, came to the conclusion, "that there is no good presumption of sterility until the fourth year of married life has been entered upon," and the accompanying table shows the intervals between marriage and the birth of the first child in his collected cases:—

Less than } one year }	608	9 years	5
1 "	2390	10 "	1
2 "	437	11 "	3
3 "	133	12 "	4
4 "	61	13 "	2
5 "	32	14 "	0
6 "	27	15 "	1
7 "	12	16 "	0
8 "	5	17 "	0
		18 "	1

Taking these facts as a basis it will be convenient, in considering tubal pregnancy, to regard an unfruitful interval of four years after cohabitation as a "period of sterility"; eight years would be a long, and sixteen years a very long period of sterility.

In order to obtain further evidence in relation to this matter, I collected 100 cases of tubal pregnancy reported in American, British, French, and German literature, in order to determine as nearly as possible the most common period of life for this accident. The cases were distributed thus:—

Between the ages of 20 and 25,	10 cases.
" " 25 and 40,	86 "
" " 40 and 45,	4 "
	<u>100</u> "

The number of cases within each lustrum, 25–30, 30–35, 35–40, were almost equally distributed: I have further tested the conclusion by reference to my own cases, and those I have witnessed in the practice of my colleagues, and the results are very constant.

In regard to uterine gestation, Matthews Duncan points out that the interval 25–35 may be regarded as the great child-bearing period of life,



and that the average duration of the child-bearing period is twelve years. I may add that in some cases in the lustrum 35-40 the foetus had been sequestered in the mesometrium (broad ligament) for several years, so that the period of functional activity of the uterus represents also the period of liability of the tubes to become gravid.

Clinical experience has taught me that these facts in regard to age, child-birth, and a preceding "period of sterility," are points to be considered in dealing with suspected cases of tubal pregnancy.

The occurrence of pregnancy in the Fallopian tubes after a long period of sterility in women who have borne children, has led some writers to believe that these patients had suffered from desquamative salpingitis, and that the destruction of the tubal epithelium had hindered the ovum in its passage to the uterus.

I have devoted much labour to the investigation of the minute changes in the mucous membrane of gravid tubes. In some specimens there is evidence of old inflammation; but it must be pointed out that salpingitis, so severe as to produce destruction of the tubal epithelium, causes profound changes in the tubes, and leads to stricture and complete occlusion of their abdominal ostia; when the tubes are denuded of their epithelium it is exceedingly rare to find the abdominal ostia patent. It is, however, well to bear in mind that salpingitis, even of a mild type, may so affect the tubal mucous membrane as to retard or altogether hinder the transit of ova; and an examination of pregnant tubes shows that salpingitis of a mild type, and without even partial destruction of the epithelium, will lead to the detention of ova and expose them to spermatozoa, which may wander into the tubes. On the other hand, in many specimens of very early tubal pregnancy I have failed, even after the most careful microscopic examination, to find any evidence of old salpingitis or loss of epithelium.

It is probable that in a small proportion of cases chronic salpingitis of a mild type may account for the sterility and the subsequent tubal pregnancy; but it fails to account for a very large number of instances. Indeed the evidence now indicates that a healthy Fallopian tube is more liable to become gravid than one which has been inflamed. Chronic salpingitis becomes even less satisfactory as an explanation of tubal pregnancy, when we reflect that, in some of the specimens, the inflammatory changes are the consequence rather than the cause of tubal pregnancy. Although changes of this character, or mechanical conditions induced by the presence of ovarian, parovarian, or uterine tumours, may explain a few cases, the causes of tubal pregnancy in most cases remain undetected.

Our knowledge of the events consequent on the retention of an oosperm in the tube is fairly complete; and, as they vary according to its position, gestation in the ampulla and the isthmus is called *tubal*, and in the portion which traverses the uterine wall *tubo-uterine* pregnancy. This latter variety will require separate consideration.

The stages of tubal pregnancy will be discussed in sections thus:—

i. Changes in the tube. ii. The tubal mole. iii. Tubal abortion. iv. Tubal rupture. v. The decidua and the placenta.

i. *The Changes in the Tube.* — During the first month or six weeks that portion of the tube in which the oosperm is lodged becomes very vascular and turgid. Occasionally the walls of the tube, at the site where the villi are implanted on the mucous membrane, stretch and grow thin from the beginning of the gestation. The rapidity of the thinning varies in different tubes; this is due to the fact that under normal conditions the Fallopian tubes vary not only in length but in thickness. In some individuals they scarcely exceed in thickness the vasa deferentia of the male, and resemble rather the narrow tubes of the mare or cow. As the tube expands from the growth of the foetus and its membranes, the mucous membrane is stretched and its folds effaced. Occasionally a few of the plicae will project within the tube as long straggling processes.

Whilst these changes are in progress curious alterations are taking place at the abdominal ostium, which, in many cases, gradually bring about its occlusion; an event usually completed by the eighth week. During the first four weeks the congestion of the parts causes turgescence of the fimbriae, as well as of the muscular and serous tissues adjacent to them. When the parts are thus swollen the margin of peritoneum adjacent to the ostium is very conspicuous, and forms an irregular ring around the fimbriae. In another fourteen days this ring projects beyond the fimbriae; lastly, it contracts and hermetically closes the ostium.

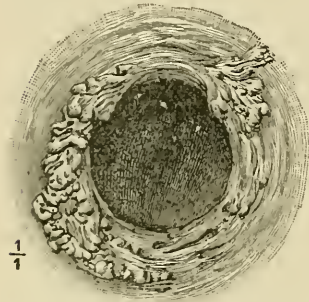

FIG. 129. — Dilated abdominal ostium; from a gravid mole-containing tube. (*Nat. size.*)

Careful observations of gravid tubes serve to show that occlusion of the abdominal ostium is by no means a constant sequel of tubal gestation; indeed, in some instances, as the tube is distended by the growing embryo, the ostium dilates: I have examined specimens in which the abdominal ostium appeared as a circular opening 4 cm. in diameter (Fig. 129). It would appear that, when the oosperm is retained near the abdominal ostium, this aperture is more likely to become occluded than when it is lodged near the middle of the tube. When the oosperm is detained in the inner third of the tube the ostium is unaffected (Fig. 130).

The condition of the mouth of the tube in some measure influences the subsequent course of the pregnancy, inasmuch as a widely expanded ostium disposes to tubal abortion; but a gravid tube with a patent abdominal ostium is also liable to rupture. A gravid tube with an occluded ostium almost invariably bursts.

Our knowledge of the condition of the uterine segment of the tube in cases of tubal pregnancy is less precise than that of the abdominal ostium, because mere examination with the naked eye, or such rough

methods as the introduction of a probe, or a bristle, are not satisfactory tests. The best means of investigation consist in the microscopical examination of thin sections of the uterine segment of the tube. This has been carried out in a few instances, and the lumen of the tube found to be uninterrupted.

The condition of the uterine segment of the tube is of some importance in connection with the clinical features of tubal gestation. It was assumed, by some of the older writers on extra-uterine gestation, that obstruction in this part of the tube would help to explain retention of the ovum in the tube. This is of course untenable, because it would likewise prevent the entrance of spermatozoa into the tube. In many cases of tubal

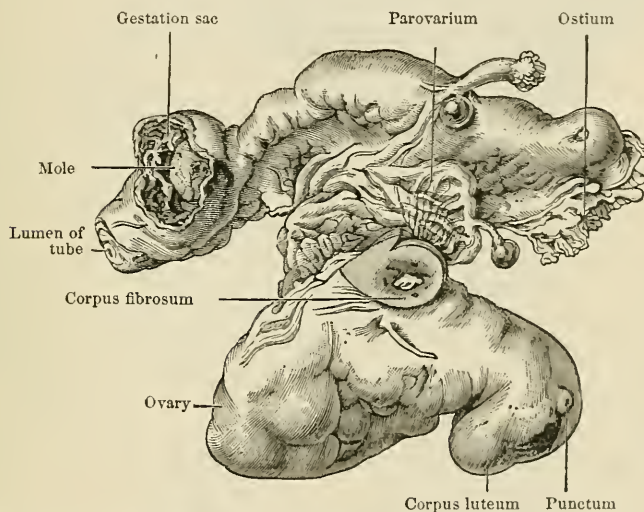

FIG. 130. — Gravid tube; the gestation sac occupied the uterine segment of the tube. The mole was equal to a green pea in size. The abdominal ostium was patent. (Nat. size.)

gestation the patient complains of irregular discharges of blood from the vagina; this seems to be observed more especially in cases of tubal abortion. It is probable that some of this blood is effused into the tube and trickles through the uterine orifice into the cavity of the uterus.

**Tubal Moles.** — The changes which occur in the oosperm subsequent to impregnation are identical, whether it be retained in the tube or the uterine cavity. In either situation it is liable to a curious change whereby it is converted into what is known as a mole.

Practitioners are familiar with uterine moles: they are so common that most pathological museums contain several specimens, and few matrons terminate the reproductive period of life without having produced one or more examples of the fleshy mole. The clinical name for the event is "abortion." When a mole is examined soon after its



discharge it resembles a firm blood-clot in colour and consistence. On dividing it, a cavity is found containing fluid, which is sometimes straw-coloured, sometimes stained red from admixture with blood. The walls of this cavity are smooth and lined with amnion, and often a misshapen

fœtus is contained within, or the stump of an umbilical cord; frequently, however, there is no trace of an embryo.

In 1889 I was able to demonstrate that moles occur in connection with tubal pregnancy; and since that date such a large number of examples have been described that the tubal mole has become a familiar object.

The characters of tu-

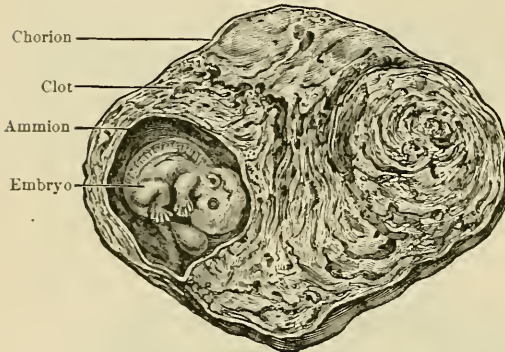

FIG. 131. — Tubal mole in section. (Nat. size.)

tubal moles may be summarised thus:—

Tubal moles vary greatly in size; some have a diameter of 1 cm., others of 5 or even 8 cm. Small moles are globular, but after attaining a diameter of 3 cm. they assume an ovoid shape.

The amniotic cavity usually occupies an excentric position (Fig. 131). Occasionally an embryo is present; often it is misshapen and ill-developed.

In a great many specimens, owing to the excentric position of the amniotic cavity, its walls are ruptured and the embryo is lost.

The outer investing membrane — the chorion — is usually shaggy with villi, which become more obvious if the mole be exposed to a gentle stream of water.

In some specimens the amniotic cavity is effaced; if such moles be sectioned and examined microscopically, the chorionic villi will be found cut transversely or obliquely.

Recent moles resemble a piece of blood coagulum and are dark red. When they have been free in the peritoneal cavity (œlom) or lodged between the layers of the mesometrium (broad ligament) for days or weeks they are sometimes yellow externally, and often firm and hard.

The majority of tubal moles are easily recognised; but a doubt may arise when the amniotic cavity is obliterated. In a doubtful case of this kind the presence of chorionic villi determines its nature. The villi usually appear as clusters of circular bodies; ten or more may, in fortunate sections, be counted together: more frequently they occur in groups of three or four, and often a wide section of clot may be examined without finding more than two or three. Under a low power they present an external layer of epithelium, the central space being occupied by irregular-shaped cells (Fig. 132). When examined under high powers a limiting layer of cubical epithelium, forming a perfectly regular row, is often to be



seen. Sometimes the interior of a villus resembles the stratum intermedium of an enamel organ. In larger villi there is often a double row of epithelium.

The structure and mode of formation of these moles are of great interest. In the early stages of development the relations of the membranes are somewhat different to those which obtain at a later period, and it is a significant fact that moles only arise in the first few weeks following

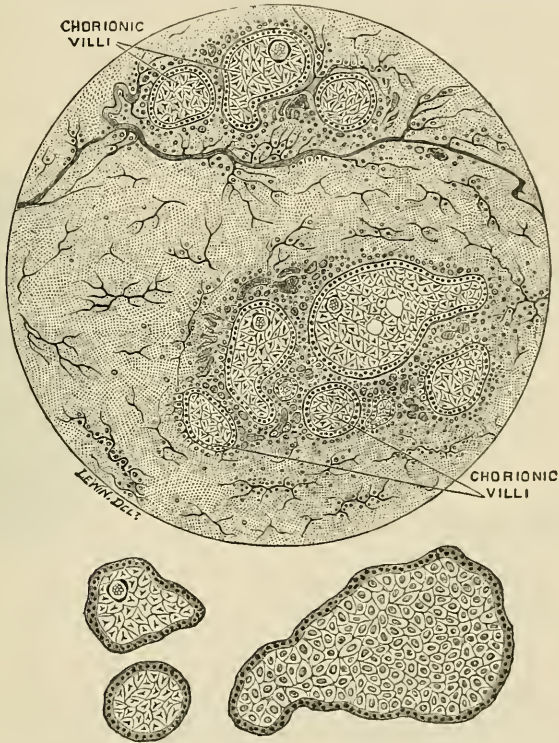

FIG. 132. — Microscopical characters of chorionic villi in section, in blood-clot.

fertilisation. Soon after the chorion is shaggy with villi the embryo will be found in the amnion; between the amnion and the chorion a space exists (which may be called the subchorionic chamber) filled with albuminous fluid (Fig. 133). As the embryo increases in size the amnion gradually encroaches on this space and eventually obliterates it; but for a time a potential space exists between the two membranes (Fig. 134) exactly resembling that between the visceral and parietal pleuræ.

The most cursory examination of a typical tubal mole will convince the observer that the blood is limited externally by the chorion and internally by the amnion (Fig. 131). It is obvious that *this blood occupies*

the subchorionic chamber. This at once explains the elliptical shape of large tubal moles.

We have now to determine the source of the blood. Many observers have hitherto been content to believe that a mole is formed by an irruption of maternal blood into the embryonic membranes. In the face of the observed facts mentioned above this loose opinion falls to the ground. The blood is furnished by the circulation of the embryo. This view is further supported by the character of the blood: the blood of the embryo differs from that of the adult by the fact that the red corpuscles are nucleated; now actual observations on blood from fresh tubal moles show that the red corpuscles are nucleated.

It is clear that a tubal mole is due to blood extravasated from the circulation of the embryo into the subchorionic chamber.

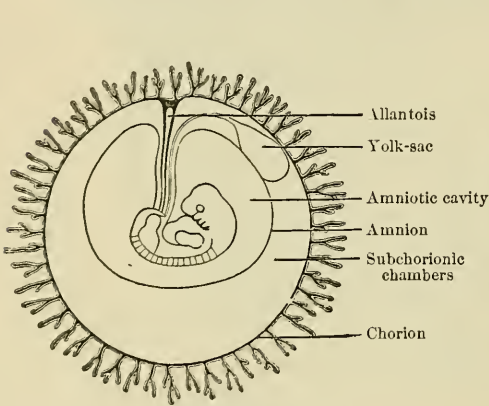

FIG. 133.—Diagram to show the early relations of the amnion and chorion and the subchorionic chamber.

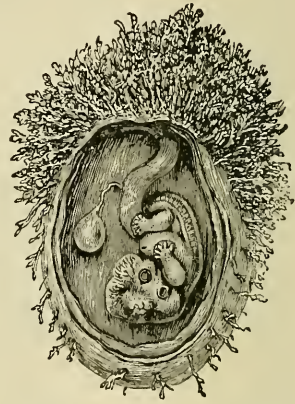

FIG. 134.—An early tubal embryo, showing the polar disposition of the villi, etc. (Nat. size.)

It must be distinctly understood that these observations only apply to blood within the chorion. It does not follow that the blood found within the subchorionic chamber is the result of a single hæmorrhage; careful examination of tubal moles demonstrates that the blood is often disposed in laminae like that found in a sacculated aneurysm. This is sufficient to prove that in some instances, at least, the formation of a tubal mole is a gradual process.

In many cases tubal moles are found immersed in blood extravasated from the maternal vessels. Occasionally mole-containing tubes come to hand in which no blood is effused between the chorion and the tube. In such cases evidence that the blood comes from some source within the chorion is irrefragable.

**Tubal Abortion.**—It has been pointed out already that the presence of an oosperm in the outer third of a Fallopian tube usually leads to occlusion of the abdominal ostium: this event is commonly complete by

the end of the sixth week; sometimes it is delayed to the eighth week; it is therefore a comparatively slow process.

So long as this orifice remains open the oosperm is in constant jeopardy of extrusion through it into the peritoneal cavity (cœlom), especially when it lies in the ampulla of the tube; the nearer it is situated to the ostium the greater the chance of this extrusion. To this accident the term "tubal abortion" is applied, for it is exactly parallel to those early abortions occurring in uterine gestation before the end of the second month; and it further resembles them in the fact that the oosperm is nearly always converted into a mole.

The term tubal abortion is applicable to cases in which hæmorrhage takes place from a gravid tube, the blood entering the cœlom through an unclosed ostium.

Many of these cases resemble early uterine abortions in which a mole is expelled, accompanied by a free discharge of blood from the uterus. In tubal abortion the same thing happens. The mole is discharged with a copious hæmorrhage into the peritoneal cavity through the ostium; the patient presents the usual signs of internal bleeding, and rapid death may occur from the consequent anæmia, or from shock. In such instances the mole, being very small, often escapes recognition when the clot is examined, whether after an operation or after death. Tubal abortion can only occur during the first two months; for when the ostium is occluded the blood cannot escape without rupture of the sac. The quantity of blood which flows from the tube into the peritoneal cavity sometimes amounts to two, three, or even four litres. Tubal abortion is a subject of much interest, inasmuch as it furnishes many of the cases of pelvic hæmatocele which are ascribed to metrorrhagia, reflux of menstrual blood from the uterus, or hæmorrhage from the mucous membrane of the Fallopian tube. The reason for associating the hæmorrhage with metrorrhagia and menstruation is due to the fact that, whilst the embryo is growing in the tube a decidua is forming in the uterus. When tubal abortion occurs hæmorrhage takes place from the uterus, consequent on the separation and expulsion of the decidua. Should this accident happen near the time the patient expects to menstruate, the case would be regarded as reflux of menstrual fluid into the peritoneum. In some cases the blood discharged from the uterus is derived from the gravid tube; this especially happens in cases of protracted tubal abortion. If it do not coincide with a menstrual period it is then usually considered to be of uterine origin. It will therefore be well, in searching blood removed in abdominal operations, to examine carefully any apparently organised ovoid clot, in order to ascertain whether it contain an amniotic cavity with or without an embryo, and also to ascertain the existence or otherwise of chorionic villi.

It is necessary to bear in mind that in early uterine abortion the mole often fails to become completely detached from the uterine wall; bleeding recurs so long as the mole is retained. In tubal pregnancy the same thing happens; the mole, so long as it is not ejected from the tube, gives



rise to recurrent hæmorrhage (Fig. 135). This may be described as *incomplete tubal abortion*, and is more common than the complete form.

Doubts have been expressed in regard to the occurrence of complete tubal abortion. In 1892 I reported the details of such a case to the Medical Society of London. At the operation I found the mole lying among the fimbriæ of the tube. There was a small rent in the tube wall. The tube, ovary, and mole are shown of natural size in Fig. 136.

A few writers are disposed to quibble over the term tubal abortion.



FIG. 135.—A gravid tube with patent ostium; the mole is shown in section. From a case of incomplete tubal abortion. (Nat. size.)

There can be little doubt that it will be possible in the future to distinguish clinically between rupture of a gravid tube and incomplete tubal abortion; the latter condition certainly gives rise to repeated bleeding. Besides this, the full recognition of the fact that a mole may be discharged through an unclosed ostium into the peritoneal cavity has helped to complete the chain of evidence that pelvic hæmatoceles have their source in hæmorrhages from gravid Fallopian tubes.

In tubal abortion the great danger lies in the fact that the bleeding is apt to be recurrent so long as the mole is retained in the tube. Noble has recorded briefly the details of a case of tubal abortion in which the blood-clots found in the pelvis were "coiled up much as though they had been ground through a sausage machine"; the blood clotted in the tube, and the clot was then forced out as a sausage-shaped mass by the continuance of the bleeding.

It is a noteworthy feature in many instances of incomplete tubal abortion that the mole very firmly retains its attachment to the tube wall (Fig. 135); the area of fixation corresponding to the placental site. In my early investigations into the nature of tubal moles I found that villi occurred abundantly in sections taken from one part, and yet were absent in those taken from other parts of the same mole. Since I detected the striking polar congregation of villi displayed in Fig. 134, I have always taken my sections from the adherent pole, and have so far never failed to find the villi in great force.

**Rupture of the Gestation Sac.**—Abortion of a gravid tube, as described in the foregoing section, is a very common termination of tubal pregnancy. Failing this the gestation sac almost invariably bursts, the only exception being the very rare event of a mole lying quiescent in the tube.

Rupture of the tube will be discussed in the sections indicated in the subjoined table:—

1. Primary rupture — (a) Intraperitoneal; (b) extraperitoneal.
2. Secondary rupture — (a) Intraperitoneal; (b) extraperitoneal.



*Primary Rupture.* — This term refers to the rupture of the tube which, in the majority of cases, occurs at some period between the third and tenth week after impregnation, and is rarely deferred beyond the twelfth week.

The predisposing causes of rupture are the gradual thinning of the

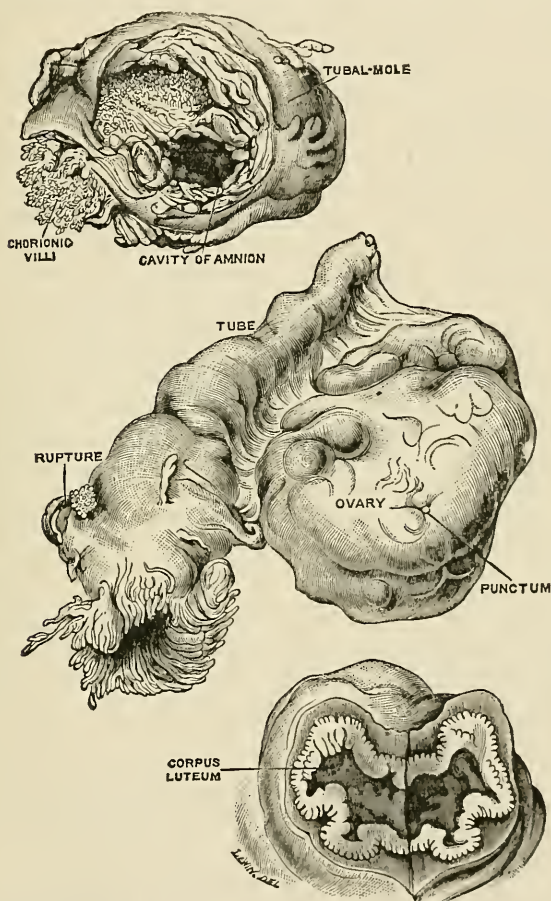

FIG. 136. — Fallopian tube and ovary, mole and corpus luteum from a case of complete tubal abortion. (Nat. size.)

walls of the gestation sac as the embryo grows, and the undue distension of the membranes by hæmorrhage. Muret has pointed out, in a very careful study of specimens, that the thinning is especially marked at the seat of implantation of the chorionic villi. Rupture is sometimes produced by violence, such as jumping from a train, stool, or carriage; straining during vomiting or defæcation, or sexual congress.

Before considering this event in detail, we may for a moment study the relation of the Fallopian tube to the mesometrium (broad ligament). The healthy tubes in the human female occupy the free borders of this structure, and, on two-thirds of their circumference, are invested by it; indeed the tube is held in position by a peritoneal investment resembling the mesentery. The portion of the mesometrium adjacent to the tube is appropriately termed the mesosalpinx.

When the tube becomes enlarged in consequence of inflammation, or dilated by an embryo growing within its lumen, the layers of the mesosalpinx are separated by the enlarging tube.

This separation of the layers of the mesosalpinx, however, does not occur along the whole extent of the tube, but is restricted mainly to its middle third. It is important to realise this, because it explains the frequency of *intraperitoneal rupture*, when the embryo is situated in the *outer third of the tube*. The anatomical evidence alone leads us to expect that when a pregnant tube bursts, the chances of this accident including the serous covering would be greatly in excess when the rupture takes place in the uncovered portion; and, as a matter of fact, intraperitoneal is to extraperitoneal rupture in the proportion of three to one.

*In primary intraperitoneal rupture* the embryo and its membranes, or a mole accompanied by a variable amount of blood, may be discharged directly into the cœlom. The quantity of blood extravasated depends upon the date of rupture. When this occurs early, the blood extravasated may amount to a few ounces; but after the first month it is usually very copious, and frequently causes death in a few hours. When rupture is deferred until the seventh week the embryo (or the mole) is not constantly discharged through the rent; and as the walls of the gestation sac are prevented from contracting, the amount of blood which escapes is often very large. When the hæmorrhage is moderate in amount, and the patient escapes the immediate dangers incidental to the accident, especially shock, the effused blood may undergo partial absorption and recovery ensue. When the bleeding is not excessive, the blood collects in the recto-vaginal fossa and floats up the coils of intestines. These, with the omentum, gradually form a covering to the fossa by adhering together; so that the blood in the pelvis is isolated from the general peritoneal cavity (cœlom). Unless hæmorrhage recur the fluid portion of the blood is slowly absorbed, and the patient recovers; but convalescence is very tardy.

Taylor has reported some valuable cases in which he demonstrates clearly enough that in some instances the blood undergoes coagulation in layers and forms a sort of spurious cyst. In my experience the walls of these spurious cavities resemble the laminated arrangement familiar to surgeons in the parietes of a hæmatocele of the tunica vaginalis testis.

The dangers of primary intraperitoneal rupture are: — i. Rapid death from hæmorrhage. ii. A fatal result from repeated hæmorrhage.

*Primary Extraperitoneal Rupture.* — In a certain proportion of cases the tube ruptures through that portion of its circumference which lies

between the separated layers of the mesosalpinx. When this happens the mole and a varying amount of blood are forced into the connective tissue between the layers of the mesometrium (broad ligament). In most cases this is fortunate for the patient, as the bleeding is checked by the pressure exerted by the resistance which occurs as the mesometric tissue becomes distended, and is arrested before it assumes dangerous proportions. Thus the blood and mole are entombed, as it were, in the mesometrium, and rarely cause subsequent trouble.

Rupture may take place and the embryo with its membranes remain uninjured and the pregnancy continue; for, no longer confined within the narrow limits of the tube, it begins to avail itself of the additional space thus offered, and burrows, as it grows, between the layers of the mesometrium.

From the manner in which this mode of rupture is sometimes described it might be imagined that the tube splits, and that the products of gestation are suddenly discharged from the tube into the mesometrium. This is not the case, or the pregnancy would in every instance come to an end from the dissociation of the foetal from the maternal structures. So far as I have been able to study the morbid anatomy of the accident, the slow and gradual distension of the tube causes it to thin and gradually yield in the part of its circumference uncovered by peritoneum until an opening forms, accompanied by sudden hæmorrhage; this produces collapse, the profundity and duration of which depend upon the amount of blood that escapes. This artificial opening gradually extends until the growing embryo and placenta make their way into the new area of connective tissue thus opened up, and by degrees occupy it, unless the life of the embryo be terminated by renewed hæmorrhage.

When pregnancy continues in this way it is spoken of as a "mesometric gestation," because the sac is formed in part by the expanded Fallopian tube and the layers of peritoneum forming the mesometrium.

Dezimeris described the development of an extra-uterine fœtus in this situation as far back as 1836, and Parry draws attention to it thus:—

"By subperitoneo-pelvic (*sous-péritoné-pelvienn*e) pregnancy Dezimeris intended to designate a variety in which the ovum, after quitting the ovarian vesicle, did not enter the Fallopian tube nor fall into the peritoneal cavity, but, on the contrary, passed between the two folds of the broad ligament, and there developed. According to this view the product of conception is situated outside the cavity of the peritoneum. That the ovum has been found in this locality cannot be doubted, but when such is the case there is every reason to believe that it reaches this peculiar situation through rupture of a tubal cyst, in which the integrity of the peritoneum was not destroyed, so that the ovum escaped between the two layers of the broad ligament, where it continued to develop. It is therefore one of the terminations of an ordinary tubal gestation."

Subsequent observation on this head has not only justified Parry's

opinion, but demonstrated the fact that in all tubal pregnancies which survive the primary rupture and continue their development, the gestation sac is formed in part by the expanded tube, but mainly by the layers of the mesometrium. The proper appreciation of this fact has done much to simplify our knowledge of tubal pregnancy; and no one has more strongly insisted upon its correctness than Lawson Tait.

It is clear from a study of Dezeimeris' paper that his observation was of a very casual sort, and he certainly failed to appreciate its importance.

*The Placenta and Decidua.* — In tubal gestation the placenta is liable to many vicissitudes which very materially influence the life of the foetus, as well as that of the mother; and as in many cases it is a source of anxiety to the surgeon, it is imperative upon those who may be called upon to deal clinically with tubal gestation to consider the subject with more than ordinary care.

The placenta formed in tubal gestation differs in several particulars from one developed in the uterus. In normal gestation the uterine mucous membrane is supposed to take a large and important share in forming the placenta; but, so far as I can judge from my own observations, the tubal mucous membrane plays a very insignificant part when pregnancy occurs in the tube.

The fully developed uterine placenta is composed of parts derived from the maternal and foetal tissues in nearly equal parts; a tubal placenta is mainly if not entirely derived from the foetal tissues.

Clarence Webster has endeavoured to show that certain changes which he describes in the deep layers of the mucosa of gravid tubes represent a decidual formation. From a thorough, careful, and repeated microscopical examination of gravid tubes in exceptionally early stages of pregnancy I have failed to find anything that can be regarded as a tubal decidua, certainly nothing that is cast off in the form of a membrane, and this is an essential qualification for a decidua.

*The Uterine Decidua.* — It is a curious circumstance in tubal pregnancy that, though no decidua forms in the tube, a decidua forms in the uterus. Few facts have been so much disputed as this, and the discussions will be found in Parry's classical work. The conclusions of Parry have been confirmed by those who have studied the subject in recent years.

My own observations are so thoroughly consonant with those of Parry that his views will be given in his own words: —

“1. In all varieties of extra-uterine pregnancy a decidua forms in the uterine cavity, as in normal gestation, but none is found in the tube.

“2. The decidua is rarely retained until the completion of gestation, and thrown off during false labour. More frequently, if the patient goes to term, it is discharged during the early periods of pregnancy in small fragments and without producing pain; or else it is expelled *en masse* with symptoms of miscarriage.

“3. The absence of a uterine decidua when death has occurred from rupture of the cyst, even in the early stages of pregnancy, is not proof



that the membrane has not been formed, but simply that it has been expelled before the death of the fœtus."

It is an interesting and curious fact that when pregnancy occurs in one-half of a bicorned uterus, a decidua forms in the unimpregnated cornu. I have myself observed that a similar condition holds good in animals normally possessed of bicorned uteri (for example, in ungulates and lemurs). In normal pregnancy no decidua forms in the Fallopian tubes or in the cervical canal. It is now well established that the destructive changes which occur in the mucous membrane of the genital tract in association with menstruation are limited to the lining of the cavity of the uterus; and that the formation of a true decidua is limited to that part of the genital tract which undergoes the destructive changes associated with menstruation and rut.

It is important not to confound a decidua of pregnancy with a decidua occurring in what is called membranous dysmenorrhœa. *Menstrual deciduæ* rarely exceed 2 or 3 cm. in length, and are scarcely 2 mm. in thickness. As a rule they are translucent, and rarely passed entire. The *deciduæ of pregnancy* are larger, and vary in thickness 6 to 8 mm. They may be described as bags resembling in outline an isosceles triangle. The base corresponds to the fundus of the uterus, and the apex to the internal opening of the cervical canal. At each angle of the triangle there is an opening. Those at the basal angles correspond to the Fallopian tubes, and the apical orifice to the cervical canal. The outer aspect is shaggy, and the inner surface is dotted with the orifices of uterine glands. The angle corresponding to the internal orifice of the cervical canal is often represented by a large opening (Fig. 137).

Up to the period of primary rupture the formation of the placenta has been proceeding in relation with the mucous membrane of the Fallopian tube; but after this event, if the disturbance of the parts be not so great as to terminate the pregnancy, the course of events is modified in a remarkable manner. We are indebted largely to the admirable investigations of Drs. Berry Hart and Carter for the facts upon which this account is based. After primary rupture of the tube the embryo and placenta (when the development is sufficiently advanced) gradually occupy a sac formed by the expanded tube and separated layers of the mesometrium, the floor of this space being formed by connective tissue and the levator ani muscle.

The ultimate effects of this gradual dislocation of the embryo and placenta depend mainly upon the original position of the placenta. Dr. Hart points out that if the embryo lie above the placenta, the latter becomes depressed between the layers of the mesometrium until it is arrested by the pelvic floor. If, on the contrary, the embryo lies

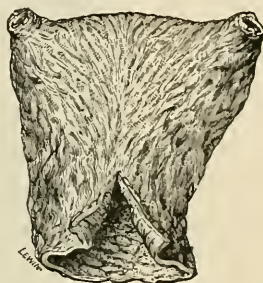

FIG. 137.—Uterine decidua: from a case of tubal pregnancy. (Nat. size.)

below the placenta, the embryo in its membranes burrows between the layers of the mesometrium, and the placenta is pushed up by the growing embryo until it lies high in the abdomen (Figs. 138 and 139). He has had opportunities of investigating the structure of these extra-uterine placentaë, and points out that in tubal gestation the villi lie embedded in decidual cells, and no intervillous sinus system seems to exist. Large sinuses, however, form in the muscular wall. The villi are well formed, and are covered with perfect epithelium. The decidual cells are large, and have a large nucleus and nucleolus. When the placenta is displaced into the mesometric tissue — and we must bear in mind that this displacement occurs gradually — the placental structure becomes seriously

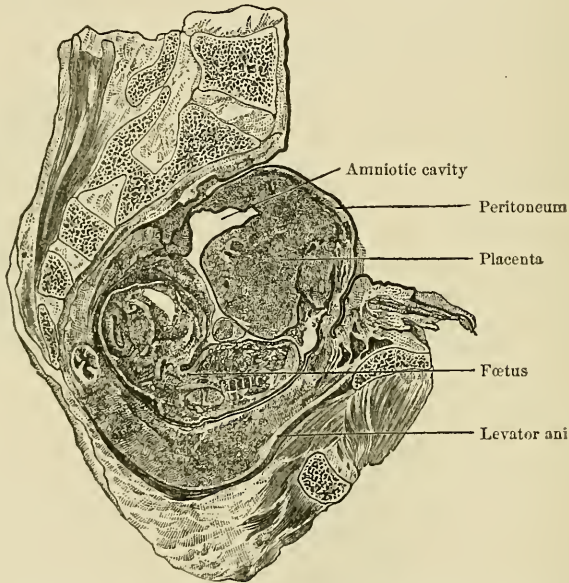

FIG. 133. — Transverse section of the pelvis of a woman with an embryo and placenta of the fourth month of gestation occupying the right mesometrium. (After Berry Hart.)

damaged. The villi are less perfect in contour, blood extravasation is present, blood crystals are abundant, and the decidual cells few and less perfect.

Dr. Hart's observations lead him to conclude, that on the displacement of the placenta from mucous membrane to connective tissue, the placenta is gradually reduced to a mass of compressed villi, the serotina is destroyed, and is replaced by blood crystals and organising blood-clot. The least damage is sustained by the placenta when the embryo is situated above it, because under such conditions it undergoes the minimum amount of displacement. The extreme disorganisation to which the placenta is liable when it forms the roof of the gestation sac may be studied even in the early stage of the pregnancy.

It must be obvious that a placenta when displaced in this way must have its function very seriously hampered in comparison with one firmly deposited on the floor of the pelvis. It has been demonstrated histologically that there is great damage produced by this slow migration.

It is of the utmost importance to appreciate correctly the structural alterations which occur in the placenta, consequent upon these remark-

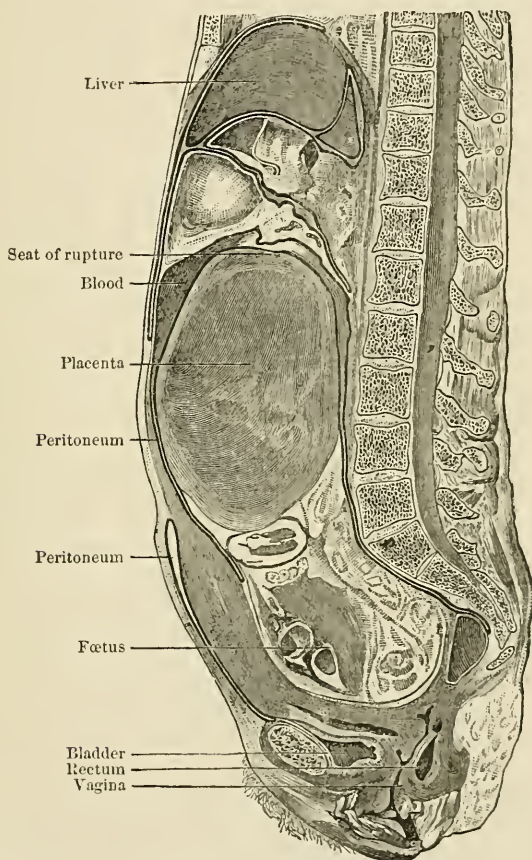

FIG. 139. — Sagittal section of a cadaver, with a mesometrium pregnancy at term; it indicates the extreme displacement of the placenta. (After Berry Hart.)

able displacements to which it is subject; they exert a great influence on the subsequent history of the pregnancy, greatly imperil the life of the mother, and in most cases are disastrous to the life of the fœtus.

The danger in which such displacements of the placenta place the mother is this:—The constant tension to which the peritoneum covering the gestation sac is subject may at any time cause it to yield, and lead to partial detachment of the placenta, and as a consequence to



severe hæmorrhage, which may take place into the gestation sac, or more probably into the cœlom. Such hæmorrhage in the late stages of these pregnancies is almost invariably fatal. Indeed, a woman with a mesometric pregnancy, with the placenta situated above the fœtus, runs a far greater risk of losing her life than when she is the victim of the dreaded condition termed *placenta prævia*.

*The Effects of Placental Migration on the Fœtus.*—We have seen already that tubal placentæ are less perfect organs than uterine placentæ. Even when a tubal placenta lies below the embryo after rupture, its structure is so damaged as to make it an inefficient respiratory organ; hence, when it is situated above the embryo, it must be much less adequate to the needs of the fœtus, and subject to the grievous vicissitudes which have been already mentioned.

The results on the embryo are very manifest. A fœtus the product of a tubal gestation is a very unsatisfactory individual. Even when rescued by the surgeon at or near time, it rarely survives longer than a few days or weeks. In many cases these infants are ill-formed, and present hydrocephalus, club-foot, spina bifida, ectopia of the viscera, or similar deformity; and, even when normal in shape, they are exceedingly defective in size. In one instance a tubal sac contained two embryos measuring 11 cm. in length, united by a band in the thoracic region (Thoracopagus).

*Secondary Rupture.*—When the pregnancy continues between the layers of the (mesometrium) broad ligament, the gestation sac may rupture at any moment; and the risk of this accident, so far as we can judge at present, is much greater when the placenta is situated above the fœtus. As the pregnancy progresses, the peritoneum forming the sac becomes stretched and stripped from adjacent parts and from the viscera. Sometimes, as the sac extends into the abdomen, it will strip the peritoneum from the anterior abdominal wall, as in the case of an over-distended bladder, only to a much greater extent. When the serous membrane is stripped from the posterior aspect of the pelvis, the rectum may be deprived of its serous investment, as well as the posterior surface of the uterus, the fœtus and placenta insinuating themselves between these parts beneath the peritoneum.

At any period between the twelfth week and term the gradually thinning gestation sac may rupture. The effects of this accident vary. When the rent involves the placenta, as it is almost certain to do when this organ is situated above the fœtus, and the gestation has advanced beyond the mid-period of pregnancy, terrible hæmorrhage and a speedy death are the usual consequence; before this date the hæmorrhage may not always be so severe, and opportunities for surgical intervention may be found. When the sac bursts into the peritoneum in this way, it is spoken of as *secondary intraperitoneal rupture*.

When the placenta occupies the pelvis, and the fœtus the abdominal portion of the sac, the latter may become so slowly thinned that at last it yields, and the fœtus disports itself among the intestines.



It must be remembered that secondary rupture may be indefinitely delayed, and in some cases never occurs. The patient goes to term, passes through a spurious labour, the liquor amnii is absorbed, the placenta disappears, and the existence of an extra-uterine pregnancy is never suspected until a mummified fœtus or a lithopædion is discovered at the autopsy (see p. 472).

Of the two forms of secondary rupture, the intraperitoneal variety may occur at any date between the twelfth week and term.

Secondary intraperitoneal rupture near or at term must be discussed more fully, because these are the cases which tend to perpetuate the belief that fertilised ova may tumble into the cœlom and engraft themselves upon the serous membrane and develop. A critical inquiry into this matter has convinced me that there is no case on record which can be cited as decisive proof of this occurrence. There is no such condition as a primary peritoneal pregnancy. *All forms of extra-uterine gestation pass their primary stages in the Fallopian tube.*

I am of opinion that the so-called primary abdominal pregnancies are primary tubal; gradually the tube opens out into the broad ligament, and as the pregnancy progresses to term the walls of the gestation sac rupture, and the fœtus escapes into the cœlom, as in the remarkable case recorded by Mr. Jessop:—

“A woman twenty-six years of age believed herself two months pregnant; she was suddenly seized with violent pain in the right side of the belly, which caused her to faint. From the effects of this trouble she kept her bed two months. Five months later, at a consultation, it was decided that she was a victim of extra-uterine gestation, and she was admitted into the Leeds Infirmary. As the woman was in a critical condition abdominal section was performed without delay. On cutting through the anterior wall of the belly, the breech and back of a child thickly coated with vernix caseosa came into view. The child had lodged in the midst of the bowels, free in the cavity of the abdomen. No trace of cyst or membrane could be discovered. The placenta was seen covering the inlet of the pelvis, like the lid of a pot, and extending some distance posteriorly above the brim, where it apparently had an attachment to the large bowel and posterior abdominal wall. The patient recovered from the operation, and the child lived for eleven months.”

From this case nothing positive can be inferred; fortunately the woman recovered, and the relation of the placenta to the gestation sac and the condition of the Fallopian tubes could not be ascertained.

Similar cases have been described by Champneys, Taylor, and others.

I have had one excellent opportunity of dissecting the pelvis of a woman who died after the removal of an extra-uterine fœtus which had escaped from the gestation sac among the intestines. I was able to isolate the displaced layers of the right broad ligament forming the gestation sac, in which a large piece of amnion was retained. The placenta had occupied the pelvis and part of the posterior wall of the uterus beneath the peritoneum. The corresponding tube and ovary were not detected.

**Tubo-uterine Gestation.** — When an oosperm lodges and develops in the section of the Fallopian tube which traverses the uterine wall, the gestation is termed tubo-uterine. This variety runs a somewhat different course from the purely tubal form.

Tubo-uterine gestation is somewhat rare; many specimens described as belonging to this class turn out on critical examination to be specimens of cornual pregnancy.

The occurrence of tubo-uterine gestation admits of no doubt whatever; and, fortunately, a few specimens exist of this accident which demonstrate its absolute independence of cornual pregnancy. Two

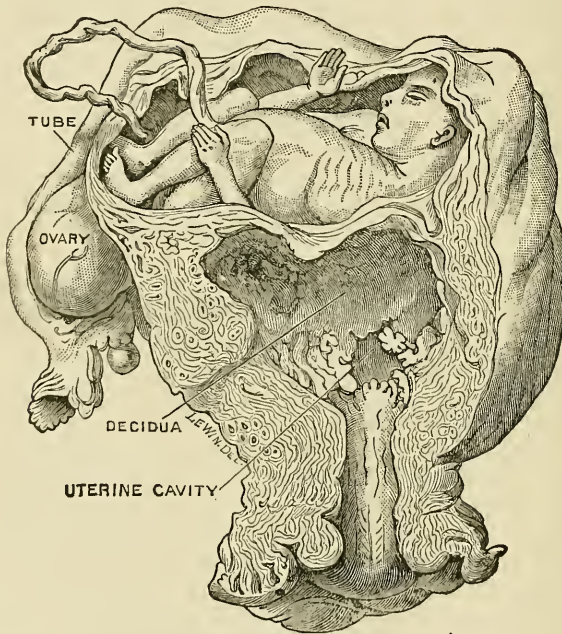

FIG. 140. — Tubo-uterine gestation. (Museum, Guy's Hospital.)

specimens — one preserved in the museum of Guy's Hospital, and the other in the museum of the Royal College of Surgeons, which has had the advantage of careful investigation by Mr. Doran — are the most satisfactory and easily accessible examples in London.

The specimen at Guy's is carefully described in the *Reports* of that hospital for 1860 by Dr. Braxton Hicks.

Doran has described in detail a uterus obtained from a woman aged thirty-two years, who died from hæmorrhage in about ten hours after rupture of the sac of a tubo-uterine gestation. An embryo enveloped in membranes, and corresponding to the second month of development, was found floating in blood in the abdominal cavity.

Tubo-uterine gestation differs in its course, anatomy, and modes of termination from the purely tubal form. In tubal gestation primary rupture usually occurs about the eighth, and is rarely deferred beyond the twelfth week; in the tubo-uterine variety it may be delayed much beyond this date.

The date of rupture in four cases is given in the subjoined table —

Braxton Hicks. — The development had probably proceeded to the end of the fourth month.

Lawson Tait. — The patient thought she had turned the fourth month.

Doran. — About the end of the second month.

Author. — About the fifth week.

The sac of a tubo-uterine gestation may rupture in two directions: It may burst into the *cœlom*, and be rapidly fatal; or into the uterine cavity, and be discharged like an ordinary uterine conception. It must be remembered that in this variety the sac does not rupture in such a way as to allow of the embryo being dislocated between the layers of the mesometrium.

An examination of the clinical details of cases of undoubted tubo-uterine gestation indicates that intraperitoneal rupture of the sac is more rapidly fatal than the tubal form; and that this is due to the greater amount of hæmorrhage, because not only are the walls of the gestation sac thicker, but the rent often extends to and involves the uterine wall.

As a means of ready reference the points in which the two varieties of tubal gestation differ from each other are arranged in tabular form: —

	Tubal.	Tubo-uterine.
Frequency.	Very common.	Very rare.
Gestation sac.	Walls are very thin.	Walls very thick.
Termination.	(a) Intraperitoneal rupture.	(a) Intraperitoneal rupture.
	(b) May rupture into the mesometric space.	(b) May rupture into uterine cavity, and be discharged through the vagina.
	(c) May abort.	
Date of primary rupture or abortion.	At any date from the 3rd to 12th week.	At any date from the 5th to the 20th week.

Although in many examples of tubo-uterine gestation primary rupture may be delayed longer than in the purely tubal form, nevertheless the sac sometimes bursts very early. In these cases death from hæmorrhage may follow within a few hours.

**Ovarian Pregnancy.** — In writings on extra-uterine gestation it has been for many years the custom to describe a variety known as “ovarian pregnancy,” an event believed to be due to the fertilisation of an ovum before its escape from the ovarian follicle.

It is extraordinary that belief in the occurrence of ovarian pregnancy should have obtained currency. Those who care to take the trouble to study the evidence in support of it, especially that collected by Campbell, will find that some of the supposed examples were as a matter of fact ovarian dermoids, and that the others were based on the most flimsy examination.

In the cases of supposed ovarian pregnancy published by observers of repute, like Martin and Leopold, the fœtus in each instance had been many years sequestered in the mesometrium; hence it is impossible to infer the relation of the gestation sac to the ovary with any certainty.

In some English cases reported as ovarian pregnancy the opinion as to their situation in the ovary was based on the circumstance that at the autopsy the ovary was not seen! Until some specimen is forthcoming in which an early embryo, in its membranes, can be demonstrated in a sac inside the ovary we need not trouble ourselves to discuss ovarian pregnancy.

**Retention of the Fœtus.** — In tubal pregnancy the life of the embryo, as has been shown in a preceding section, is very precarious. Yet in the face of all these possibilities the gestation may run on to term. Then symptoms of labour set in, and as delivery by the natural channels is impossible, the gestation sac may burst into the cœlom, with all the attendant evils of this event. If it escape this catastrophe the fœtus dies, and the body may either remain quiescent or may give rise to various forms of disturbance.

In the more fortunate cases the unavailing labour is (p. 475) followed by absorption of the liquor amnii, and the tissues of the fœtus may become mummified, or they may be partially calcified to form a lithopædion; the soft parts may be converted into adipocere, or the tissues may otherwise decompose. The placental tissues gradually and completely disappear.

**Mummification.** — To produce this state the fluid parts become absorbed, and the soft parts are converted into dry tissue, so that the fœtus resembles a mummy, or the dried cats so commonly found under the floors of old dwellings.

The length of time an extra-uterine fœtus may be retained is sometimes very great. In Cheston's celebrated case a lithopædion was retained fifty-two years. Dr. Barnes reported a case in which a lithopædion was retained forty-two years.

A retained fœtus may give trouble at any time. Pathogenetic microorganisms obtain entrance to the sac from some of the adjacent hollow viscera (rectum, intestines, bladder, etc.) and establish suppuration. The pus may find its way through the abdominal wall or penetrate into the vagina, uterus, rectum, or bladder. Through fistulæ thus formed fragments of fœtal tissues from time to time escape. It has been demonstrated that a woman may have a lithopædion or a macerated fœtal skeleton in her mesometrium and yet conceive in the uterus.

**The Diagnosis of Tubal Pregnancy.** — The symptoms of tubal gestation vary considerably according to the stage to which gestation has



advanced. It will be necessary, therefore, to deal with it in the following stages:—

i. Before primary rupture or abortion; ii. At the time of primary rupture or abortion; iii. From primary rupture to term; iv. After term.

Before proceeding to discuss the signs which occur during each of these stages, it is necessary to point out that the patient is sometimes aware that she is pregnant. In many cases, however, she is not aware of the fact, and the practitioner is often deceived by the absence of the usual signs of gestation, such as fulness of the breasts and amenorrhœa. The breast signs are very variable in tubal gestation. In many cases they are absent even when the pregnancy has gone on to the fifth month; in others the signs of pregnancy are as clear and as marked as in normal gestation. In one of my cases milk was present in one breast only, and that was on the same side as the gravid tube. Speaking generally, the absence of the usual signs of pregnancy do not negative the existence of tubal gestation; on the other hand their presence is valuable, and may lead to a correct diagnosis.

i. *Before Primary Rupture.*—Gravid tubes have in many instances been removed before primary rupture or abortion; but in nearly all the instances recorded before 1891 the operations were undertaken for the purpose of removing diseased tubes: on examination of the tubes after removal the fact that they were gravid was revealed. Since this date the pathology of the early stages of tubal pregnancy has been better understood, and a clear distinction recognised between a gravid tube and a hæmatosalpinx. Many cases have accordingly been published in which a correct diagnosis was made before the operation was undertaken. This is very gratifying, for it is a matter of the utmost importance to the patient, as it spares her the awful peril which attends the rupture of the tube. The chief points in this stage are that a woman previously regular gives a definite history of a missed menstrual period; soon afterwards she suffers from pelvic pain which induces her to seek advice; on examination an enlarged Fallopian tube is detected. If there be no history of old tubal disease, or any fact in the history of the patient suggesting septic endometritis or gonorrhœa, then the presumption is in favour of a gravid tube.

ii. *Primary Rupture.*—In tubal gestation the sac ruptures or abortion occurs at some time before the twelfth week. The effect upon the patient depends upon the seat of rupture. When the rupture takes place between the layers of the mesometrium the symptoms will, as a rule, be less severe than when the tube bursts into the peritoneum. The pressure exercised by the blood extravasated into the tissues of the mesometrium tends to check hæmorrhage, whereas the cœlom will hold all the blood the patient possesses, and yet produce no hæmostatic effect by pressure.

The signs of intraperitoneal rupture are those characteristic of internal hæmorrhage. The patient complains of a sudden feeling as if

"something had given way," and this is followed by general pallor and faintness; the voice is reduced to a faint whisper; the respiration is sighing; the temperature depressed; the pulse rapid and feeble; and vomiting usually sets in. In some cases death ensues in a few hours.

Should the patient recover from the shock, she will sometimes state that she suspected herself to be pregnant. The symptoms of rupture are often accompanied by hæmorrhage from the vagina; and shreds of decidua are passed, so that the case in many points resembles early uterine abortion, and is occasionally mistaken for it. Error in such circumstances may be avoided by examining the shreds discharged from the uterus; if they are found to be chorionic villi the pregnancy is clearly uterine. This simple test has been useful to me on several occasions.

The rapidity with which the rupture of a gravid tube will sometimes destroy life has caused more than one writer to describe this accident "as one of the most dreadful calamities to which women can be subjected." Indeed, it may be so rapidly fatal that in many recorded cases death was attributed to poisoning, until dissection, instituted in many instances by the coroner, revealed the true cause of death. In 1880 a well-known English actress was taking an ice at a café in the Bois de Boulogne when she suddenly died. Poisoning was suspected, and the corpse was sent to the morgue. At the autopsy the stomach and digestive organs were examined for poison. No traces of poison were found, but a gravid tube which had burst.

An analysis of many careful records, and the inspection of specimens of gravid tubes, demonstrate that the most dangerous cases are those in which the embryo or mole is lodged in the uterine or inner third of the tube. Death sometimes follows rupture in three or four hours.

In some of the recorded cases rupture occurred soon after the patient had retired to bed. On inquiry in one case I ascertained that sexual congress determined the rupture of the gestation sac.

It is important to bear in mind that the severe disturbance which is usually set up by primary intraperitoneal rupture of a gravid tube is simulated by lesions of other abdominal viscera; for example, by perforating ulcer of the stomach, duodenum, small intestine, or vermiform appendix; rupture of a pyosalpinx; acute axial rotation of an ovarian tumour; acute intestinal obstruction; renal colic, and biliary colic when unaccompanied by jaundice.

On the other hand, the profound shock which usually accompanies the bursting of a gravid tube has been confounded with each of the above-mentioned lesions. Malherbe reported the details of a case in which a woman thirty-four years of age was submitted to operation for supposed strangulated inguinal hernia. On opening the sac it was found filled with blood; the parietes were freely incised, and a gravid tube which had burst was found and removed.

iii. *From Primary Rupture to Term.* — From the third month onwards the *leading signs of tubal gestation* may be summarised thus: —

(a) Amenorrhœa is occasionally found; frequently there is hæmor-

rhage from the uterus, occurring at irregular intervals, accompanied by the escape of decidua: this is a valuable diagnostic sign when associated with the physical signs of a tumour outside the uterus. It is even more valuable if the patient have missed one or two periods.

(b) There may or may not be milk in the breasts. Its presence is a valuable indication. From its absence nothing to the point can be inferred.

(c) The uterus is slightly enlarged; the os is usually soft, as in normal pregnancy, and patulous.

(d) A large and gradually increasing swelling exists to one side and behind the uterus. Occasionally the foetal heart can be heard, and in advanced cases the outlines of the foetus may be distinguished.

(e) When a woman in whom the existence of tubal gestation is suspected is suddenly seized with collapse and all the signs of internal bleeding, it is indicative of rupture of the gestation sac.

(f) Tubal pregnancy is very apt to occur after long intervals of sterility.

iv. *After Term.*—In spite of all the risks that beset the life of a tubal foetus and that of its mother, the pregnancy may go to term. Then a remarkable series of events ensues.

(a) Paroxysmal abdominal pains come on, resembling those of natural labour, accompanied by a discharge of blood and mucus from the uterus resembling the “show,” and the os uteri dilates.

(b) This unavailing labour may last a few hours or days (it is stated to have lasted for weeks in some patients), and then subside.

(c) The mammae may continue to secrete milk for several weeks.

These signs sometimes pass away, the amniotic fluid is absorbed, the swelling diminishes in size, and the retained foetus causes no trouble. In the majority of cases suppuration takes place in the sac, the foetus decomposes, and the fragments of its tissues are discharged through sinuses in the groin, abdomen, vagina, rectum, or bladder. It should be remembered that the onset of labour may rupture the sac.

In *extraperitoneal rupture*—that is, when the tube bursts so that the blood is extravasated between the layers of the mesometrium—the symptoms resemble intraperitoneal rupture, but as a rule are not so severe, and the signs of shock pass off quicker. On examining by the vagina a rounded, ill-defined swelling will be found on one side of the uterus; when the effused blood is large in amount the uterus will be pushed to the opposite side. When the bleeding takes place into the left mesometrium it will sometimes extend backwards under the peritoneum, and invade the connective tissue around the rectum; so that when the exploring finger is introduced into the rectum, a semicircle, sometimes a ring, of swollen tissue will be felt encircling the gut.

The escape of decidua from the uterus, accompanied by blood, is also an important and fairly constant sign. Occasionally it will be necessary to pass a sound into the uterus; when the tube is gravid the cavity of this organ will be found slightly enlarged, and the os is

invariably patulous. The greatest difficulty in these cases is to be sure that the rupture is purely extraperitoneal. In a few cases the rupture may involve the peritoneal as well as the mesometric segment of the tube.

Not infrequently after primary extraperitoneal rupture the symptoms of shock pass off, and the embryo continues its development; in many instances in which the patients believe themselves pregnant, the hæmorrhages from which they suffer, and the signs indicative of the primary rupture, may cause but temporary inconvenience. As the embryo grows the abdomen increases in size, but the enlargement differs from ordinary uterine gestation in that it is lateral instead of median.

**The Differential Diagnosis of Tubal Pregnancy.**—The diagnosis of tubal pregnancy is nearly always beset with anxiety, which becomes intensified when complications exist. For instance:—

i. Uterine and tubal pregnancy are sometimes concurrent. ii. Uterine pregnancy sometimes follows the tubal variety. iii. Tubal pregnancy may be bilateral. iv. Tubal pregnancy may be repeated. v. Tubal pregnancy and ovarian or parovarian tumours may co-exist.

It is important to bear in mind that tubal pregnancy may be simulated by a variety of conditions:—

(a) Uterine pregnancy. (b) Pregnancy in a bicorned uterus. (c) Retroversion of a gravid uterus. (d) Spurious pregnancy. (e) Ovarian tumours. (f) Uterine tumours. (g) Mesometric tumours. (h) Fæces in the rectum.

*Concurrent Uterine and Tubal Pregnancy.*—Several examples of this combination have been recorded. In 1881 Dr. Galabin described an instance of it in a woman thirty-six years of age.

The history suggested ovarian cyst complicated with pregnancy, and that the cyst had ruptured. A combined intra-uterine and extra-uterine gestation was regarded as possible. Dr. Galabin performed abdominal section. On opening the peritoneum a foetus was discovered enclosed in its membrane lying to the right side of, above, and somewhat behind the uterus. The placenta appeared to be spread out very widely, and attached chiefly to the posterior surface of the right broad ligament and of the pregnant uterus. The placenta was not disturbed. Two days later labour pains came on, and the intra-uterine child was delivered; it was dead. The patient continued to lose blood from the extra-uterine sac, and died three days after the operation. No autopsy was allowed.

Franklin met with the same combination in a woman, mother of five children. The patient was in labour when difficulty was experienced; Cæsarean section was performed, and an adventitious mass was found in the pelvis: this was found to be an extra-uterine child. Death followed in half an hour. Similar cases have been reported by Cooke, Sale, and Wilson.

Other examples have been reported, but these illustrate the leading points in the clinical history of this accident. Its gravity is sufficiently obvious, for in all the reported cases the patients died within a few days



of the operation. The great difficulty in this, as in all other examples of advanced extra-uterine gestation, is the excessive risk of hæmorrhage which follows interference with the placenta.

*Uterine subsequent to Tubal Gestation.*—It has been mentioned that tubal gestation may go to term, spurious labour supervene, and the fœtus become sequestrated in the mesometrium: on this grave accident uterine pregnancy may supervene,—a combination, fortunately for mothers, very rare.

Stonham, whilst conducting an autopsy on a woman forty-three years of age, who died in the seventh month of her pregnancy from bronchitis and ulceration of the trachea, found a fœtus (enclosed in a thick membrane) in the right mesometrium. Some of the bones were completely macerated; the soft structures were soapy in consistence. There was a thin deposit of calcareous material on the inner wall of the cyst. The left mesometrium was normal. The uterus contained a seven months' fœtus, which was apparently living at the mother's death since it showed no signs of maceration. Worrall of Sydney published details of a case in which a woman with a fœtus in the mesometrium subsequently conceived in the uterus. The nature of the case was correctly diagnosed, and an operation for the relief of the condition was successfully carried out.

The patient was thirty years of age, and mother of five children. In April 1888, the menses having been absent six weeks, she was seized in the night with severe abdominal pains, faintness, and vomiting. She was confined to her bed six weeks. In October of the same year, at about the eighth month of gestation, a sudden flooding, unaccompanied by pain, came on, and lasted three days. A month later she was seized with severe abdominal pains, which lasted a fortnight; she then began to decrease in size, and menstruation reappeared. The tumour decreased to a certain point, and then remained stationary. After July 1889 she ceased to menstruate, and her abdomen gradually enlarged. A few months later Dr. Worrall was consulted, and he correctly diagnosed the existence of a living intra-uterine fœtus and an extra-uterine fœtus which had been dead about two years. Acting on this diagnosis, he removed the extra-uterine fœtus from the left mesometrium. It was not decomposed, but was very flaccid, and weighed  $4\frac{1}{2}$  lbs. The placenta was left, and the sac drained. Next day labour came on, and the intra-uterine child was born. It was a female, and cried feebly, "but, in spite of every care, died in a few hours." The patient made a good recovery.

Bozeman has recorded a case in which uterine supervened on extra-uterine gestation. After delivery of the intra-uterine fœtus an uneven and projecting mass presented in the recto-vaginal fossa. This proved to be the sac of an extra-uterine pregnancy. From the history of the case it had probably been dead between three and four years. The contents of the sac were evacuated through the vagina. The patient recovered.

*Bilateral (Concurrent) Tubal Pregnancy.*—Several suspected examples of this rare condition have been recorded, but in many the evidence was not absolute. In 1892 Dr. W. Walter sent me two Fallopian tubes

which he had removed from a woman twenty-nine years of age. The left contained an embryo and placenta; the walls of the gestation sac had burst and caused severe bleeding, which led to operation. The right tube contained a typical tubal mole. This, so far as I know, is the first indisputable example of pregnancy occurring concurrently in both Fallopian tubes of the same individual.

*Repeated Tubal Pregnancy.* — Under this heading it is usual to place those cases, fortunately rare, in which women have conceived in one tube and have been submitted to operation; and that subsequently the remaining tube became gravid.

Dr. Herman has recorded an example of this condition. In January 1887, he removed from a woman twenty-eight years of age a gravid right Fallopian tube which had burst into the peritoneal cavity. In May 1890 the patient again came under observation for pelvic trouble, and Herman came to the conclusion that the woman was again the victim of tubal pregnancy. Abdominal section was performed and the left Fallopian tube was removed. It contained a tubal mole.

Mr. Lawson Tait, in 1885, operated on a woman twenty-five years of age, and removed a gestation sac with the foetus and placenta from the right side of the pelvis. This woman recovered, and eighteen months later was confined of a child at term. Fifteen months after delivery she again became pregnant, and when, according to her computation, the pregnancy had advanced to the fourth month she was seized with a severe abdominal pain and died in five hours. At the autopsy a tubo-uterine gestation was found on the left side.

Mackenrodt reported the case of a woman thirty-two years of age who was seized in May 1890 with signs indicating rupture of a gravid tube. These signs were repeated in October 1891. The abdomen was opened, and a gestation sac the size of a large egg removed from the left side. On the opposite side a second sac was found containing foetal bones.

*Twin Tubal Pregnancy.* — A few writers on extra-uterine pregnancy, Parry especially, deal with the subject of twins in tubal pregnancy as if it were a common event. A critical study of Parry's writings shows clearly enough that he confounded three distinct conditions: —

i. Concurrent tubal and uterine gestation. ii. Uterine subsequent to tubal pregnancy. iii. Twin gestation in a Fallopian tube.

An example of tubal twins has yet to be recorded.

*Tubal Pregnancy and Ovarian Tumours sometimes co-exist.* — Several instances have been recorded in which ovarian or parovarian cysts have co-existed with a gravid tube. In some cases a parovarian cyst has existed on the same side as the pregnant tube, and may perhaps have determined the accident. In a case under my own care an ovarian cyst as large as a cocoa-nut existed on the right side and a gravid tube (which had aborted) on the left.

It is rarely that an ovarian tumour co-existing with uterine pregnancy simulates combined tubal and uterine pregnancy. In 1891 Dr. Griffith communicated to the Obstetrical Society details of a case in which a

woman in labour came under his care. She was supposed to have twins, one intra-uterine and the other extra-uterine. It ultimately turned out that the patient was pregnant, and what was supposed to be the head of an extra-uterine child was a large fibroma of the ovary obstructing labour. She died, and the pelvis with the organ and tumour in position was bisected; one-half of the specimen is preserved in the museum of the Royal College of Surgeons, the other in that of St. Bartholomew's Hospital, London.

*Normal Pregnancy.*—This has been mistaken for tubal pregnancy. The abdomen has been opened, the fœtus extracted, and the uterus amputated before the error was discovered.

*Pregnancy in one Horn of a Bicorned Uterus.*—A few cases are known in which this anomaly has led to grave difficulty in diagnosis and to error in treatment. Pregnancy in the ill-developed horn of the so-called "unicorn" uterus requires the same treatment as tubal pregnancy.

*Abnormal Thinness of the Walls of a Gravid Uterus.*—Lawson Tait has drawn attention to some cases which have fallen under his notice in which the walls of the uterus were of such extreme thinness that the fœtus could be easily felt. And in reference to one case he writes, "The child could be felt with the most astonishing distinctness, and it floated about as if it were perfectly free in the abdomen." There is also a reference to a similar condition in Parry's well-known work. That this is a condition to bear in mind the following case, furnished me by a surgeon, well illustrates:—

A woman, twenty-nine years of age, was admitted into the infirmary in such an anæmic and emaciated condition that she was too weak to stand. There was vomiting, amenorrhœa of six months' standing, pigmentation along the linea alba, and milk in the breasts. The belly was distended, and in the right iliac fossa was lodged a crescentic mass not unlike a fœtus in outline, and so mobile that it could be pushed into the right iliac fossa. The remarkable ease with which this body could be grasped, and its position when at rest, led to the diagnosis of extra-uterine pregnancy, and an operation decided upon. On incising the peritoneum a smooth glistening body of a pearly gray colour, exactly like an ovarian cyst, was seen, but it had the shape and occupied the position of the uterus. The fœtus could be felt and pushed about in the fluid with ease. The wound was at once closed. Miscarriage took place on the third day. The woman recovered.

In such cases, when the diagnosis is so doubtful, before resorting to operation the employment of a uterine sound would easily determine the nature of the case.

*Retroversion of the gravid uterus* has been a source of error. Retention of urine, so characteristic of this condition, is occasionally produced when the embryo occupies the mesometrium, accompanied by much hæmorrhage. On the other hand extra-uterine gestation has been mistaken for retroversion of a gravid uterus. Dr. Godson relates a case which occurred in a woman who had been married thirteen years. A

year after marriage she had one child. She remained sterile for twelve years, and then became pregnant. On account of inability to pass water she was admitted into St. Bartholomew's Hospital, and an ineffectual attempt made to replace the uterus. Eventually Dr. Carter removed an extra-uterine foetus by abdominal section.

*Spurious Pregnancy.*—It is well known that in several instances the abdomen has been opened under the impression that the patients were suffering from tubal pregnancy, but nothing abnormal found.

Dr. Sinclair Stevenson reported a case of spurious pregnancy simulating ectopic gestation of the fourth month in which there was amenorrhœa. So strongly marked were the signs of tubal pregnancy that the abdomen was opened; instead of pregnancy a small cyst of the ovary was found.

Lastly, the difficulties which sometimes beset the differential diagnosis of pelvic swellings is shown by the fact that in very many instances abdominal section has been undertaken to remove supposed ovarian tumours, dilated tubes, and the like, which turned out to be gestation sacs. This is no reflection on the surgeon, and the interference is more than justified.

Mr. Skene Keith has briefly mentioned a case in which his father performed abdominal section, expecting to find a "fibroid tumour"; but on cutting into it, a foetus was found which had been dead nearly two years.

Mr. Knowsley Thornton and others have dissected out gestation sacs under the belief that they were dealing with tumours.

On the other hand, operations have been undertaken under the impression that the patients were victims to advanced extra-uterine pregnancy; but tumours and even a mass of fæces in the rectum have been found instead.

Sir John Williams writes: "I once saw a swelling, which appeared to be a small ovarian cyst, aspirated. It proved afterwards to be the placenta in a case of extra-uterine gestation."

One of the gravest errors is to mistake a tubal pregnancy in its mesometric stage for a sarcoma or myoma when the parts have been exposed by abdominal section. This is a serious error, as the operator, instead of opening the sac, attempts to remove the tumour, usually with a fatal result.

**The Treatment of Tubal Gestation.**—The admirable results which have followed the treatment of tubal pregnancy by abdominal section have served to establish this method on as secure a footing as ovariectomy.

Methods formerly advocated, such as killing the fetus by injecting drugs into its body, or, more recently, by electricity and similar unsurgical procedures, are of such an unsatisfactory character that they will not be considered.

The risks and difficulties of an operation for tubal pregnancy depend mainly upon the extent to which gestation has advanced at the time the operation is performed. The operative treatment may be considered in the following stages:—



i. Before primary rupture or abortion. ii. At the time of primary rupture. iii. Subsequent to rupture. iv. When the embryo and placenta occupy the mesometrium. The fourth stage must be considered in sections, thus: (a) At or near term, the child being alive. (b) At, near, or after term, the child being dead, mummified, or reduced to a *lithopedion*. (c) After decomposition of the fœtus and suppuration in the sac.

i. *Before Primary Rupture or Abortion*.—Opportunities of dealing with cases in this stage are uncommon, as gravid tubes rarely cause trouble before they rupture or abort. When the evidence is convincing, cœliotomy should be performed without delay.

ii. *At the Time of Primary Rupture or Abortion*.—The majority of cases of tubal pregnancy come under observation at the time of primary rupture or abortion, and this is usually some period between the fourth and twelfth week.

When the symptoms of hæmorrhage are unmistakable and the patient's life in grave danger, cœliotomy should be performed without delay, unless there be good evidence that the rupture is extraperitoneal. The employment of this method is in strict accordance with the canon of surgery, valid in other regions of the body, namely, to arrest hæmorrhage at the earliest possible moment.

There are few accidents that test the skill, nerve, and resource of a surgeon more than cœliotomy for a suspected intraperitoneal rupture of a gravid tube, and few operations are followed by such brilliant results.

The method of performing the operation before and at the time of primary rupture is identical with oophorectomy.

Occasionally the rent in the tube may extend to the fundus of the uterus, especially if the embryo be lodged near the uterus. Such rents should be carefully sutured with cat-gut; occasionally it will be necessary to use silk to control the bleeding.

iii. *After Primary Rupture*.—Cases are submitted to operation at periods varying from a few days to weeks or even months after the tube has ruptured. It has been already pointed out that in an exceedingly large proportion of these cases the tube is occupied by a mole.

When the tube bursts the hæmorrhage may not be so profuse as to induce death, and the patient, recovering from the shock, may not manifest such grave symptoms as to make surgical aid obviously necessary. The consequence is that the patient remains for several weeks under palliative treatment (unless a renewal of bleeding killed her). At last surgical aid is sought, and a discovery of the true nature of the case leads to cœliotomy.

In such cases, when the abdomen is opened, the free blood is easily washed out by a stream of warm water. The damaged tube and ovary are removed as in oophorectomy. When much free blood exists in the peritoneal cavity care must be taken that no clots are allowed to remain in the iliac fossæ. When blood has remained in the peritoneal cavity for several weeks after rupture it is invariably necessary to drain.

The cases in which abortion or rupture of gravid tubes gives rise to

intraperitoneal bleeding moderate in amount, and insufficient to give rise to symptoms which directly threaten life, are those in which the effused blood eventually becomes shut off from the general peritoneal cavity by adhesions of intestines and omentum, as explained in the section dealing with primary intraperitoneal rupture (p. 462).

Experience has not yet decided whether it is safer for the patient under such conditions to run the risks of immediate operation or to wait for a few weeks in order to ascertain if absorption will occur. At present I believe the patient's interests are best served by allowing her to recover from the immediate shock, and then dealing with the damaged tube by cœliotomy.

iv. *Mesometric Gestation.* — When the tube bursts between the layers of the mesometrium operative interference is rarely called for. In a small proportion of cases the embryo survives the accident and continues to grow; and at any date from this period, up to term, surgical interference may be called for to save the patient from the disastrous effects of secondary rupture into the cœlom.

When gestation has not advanced beyond the fourth month, it is possible to remove the embryo, tube, ovary, and adjacent portion of the mesometrium with the placenta, and thoroughly to remove all blood-clot.

When gestation has advanced beyond the fourth month the placenta has become too large to be dealt with in this summary manner; at the same time, the sac has encroached upon the peritoneum belonging to adjacent organs, such as the uterus and rectum, the bladder, and not infrequently the anterior wall of the abdomen.

After the fifth month operative measures for tubal gestation must be considered under two headings:—(a) The treatment of the sac; (b) The treatment of the placenta.

(a) *The Treatment of the Sac.* — The gestation sac in the last stages of tubal pregnancy consists of the remnants of the expanded tube and the mesometrium, which may be thickened in some parts and expanded in others. Coils of intestine and omentum usually adhere to the walls of the sac. The removal of such a sac is fraught with considerable risk, not only to the adjacent large blood-vessels, but to the viscera and ureters. Nevertheless, in spite of the great risk of the proceeding, it has on one occasion been successfully accomplished, and the patient luckily recovered. It will generally be found that in cases where attempts have been made to dissect out the sac, the operation was begun under the impression that the abnormal mass was a tumour.

Experience has decided clearly enough that the safest plan is to incise the sac, remove the fœtus, and stitch the edges of the sac to the abdominal wound; precisely as in the plan recommended after enucleating large cysts and tumours from between the layers of the mesometrium.

In those cases where the gestation has well advanced, the peritoneum may be so removed from the anterior abdominal wall that the sac can be penetrated without intentionally opening the peritoneal cavity at any stage of the operation.

(b) The chief difficulty which perplexes the operator is how to deal with the placenta. There can be no doubt that the situation of the placenta largely influences the result, and so far as I can judge from the reports of cases, as well as from my own experience, the most promising cases are those in which the placenta is situated in the pelvis below the fœtus. When the placenta is situated above the fœtus it will, in many cases, be incised as the sac is opened, and give rise to such furious bleeding that in several cases the patient has succumbed to the hæmorrhage. Even prompt seizure and ligature of the pedicle on the uterine side of the sac fail to arrest the bleeding; in such a case the abdominal aorta must be compressed; and such methods as packing with sponges and the application of perchloride or persulphate of iron to the bleeding surfaces have been adopted, in a few instances with success.

The fear of such hæmorrhage and its uncontrollable character have induced several surgeons to adopt the alternative plan of leaving the placenta, and allowing it to slough away gradually, taking care, of course, to keep up a free communication with the exterior. The disadvantages of this method are many. The process of suppuration and discharge of the placenta is long and dangerous on account of the great risk the patient runs of septicæmia and peritonitis; in a large proportion of cases a fæcal fistula forms; in the majority of cases, however, such fistulas gradually close as the patient convalesces.

In order to avoid this risk attempts have been made, after removing the fœtus, to irrigate the gestation sac, and to tie the cord thoroughly close to the placenta without disturbing the latter; the cavity must be cautiously sponged and then hermetically closed, in the hope that the placenta will atrophy. Unfortunately for this method there is another source of infection to reckon with. It has already been mentioned that, as the gestation sac enlarges, it frequently strips the peritoneum from the rectum, and thus the placenta itself may acquire adhesions to the bowels. The result is that intestinal micro-organisms gain access to the placenta and set up decomposition.

With our present experience the rules for the treatment of the placenta may be formulated thus:—i. When the placenta is situated above the fœtus it is good practice to attempt its removal. ii. In some instances the placenta becomes detached in the course of the operation, and leaves no choice. iii. When the placenta is below the fœtus it may be left. iv. Should the placenta be left, and the sac closed, and thereafter symptoms of suppuration occur, then the wound must be reopened and the placenta removed. v. If the fœtus die before the operation is attempted the placenta can be removed without risk of hæmorrhage.

Could we feel sure that the placenta would not decompose, the best method would be to close the sac hermetically, and leave the placenta to atrophy; or to wait until we know that the placental circulation had ceased, then reopen the sac and take out the placenta. Unfortunately, we have no precise data to guide us in this respect, and whilst waiting for the placenta to die, its tissues decompose.



Apprehension that the placenta may grow after the fœtus has been removed is absolutely groundless; there is positive evidence that, if it does not decompose, it quietly and completely atrophies. This is further proved by the absence of placenta, when the fœtus is in the state of lithopædion.

The great risk of violent hæmorrhage renders an operation for tubal pregnancy with a quick placenta between the fifth and ninth months of gestation the most dangerous in the whole range of surgery; hence it cannot be urged with too much force that *as soon as it is fairly evident that a woman has a tubal pregnancy, it should be dealt with by operation without delay.*

It has been urged that if, after primary rupture, there is evidence that the child is developing, operative interference should be deferred until the seventh month, unless urgent symptoms arise, as there may be a prospect of saving the child's life. To my mind this is an objectionable practice, for the following reasons:— i. Extra-uterine children are puny, ill-developed and, in a large proportion of cases, malformed. ii. They rarely survive extraction many weeks, or many months at most. iii. In endeavouring to save the life of a defective child the more valuable life of the mother is frequently sacrificed. It is, of course, conceivable that in some cases the life of the child may be of great importance.

*After Death of the Fœtus at or near Term.*— Operations after the death of the fœtus are less complicated than when it is alive and the placental circulation in full vigour. Not only is the proceeding simplified from the operative point of view, but the results, in so far as the mother is concerned, are also much more satisfactory.

When the operation is undertaken in cases where the fœtus is in the state of lithopædion the procedure is very simple, because the placenta has completely disappeared. There is a circumstance in connection with a fœtus wholly or partially converted into *adipocere* which is of some importance to the surgeon, namely, that its tissues have a strong tendency to adhere to the walls of the sac.

*After Decomposition of the Fœtus and Suppuration of the Sac.*— After death and decomposition of the fœtus fistulas form, by which pus, accompanied by fragments of fœtal tissue and bones, finds an exit— either through the rectum, vagina, bladder, uterus, or at some spot in the anterior abdominal wall below the umbilicus. The treatment in such cases is simplicity itself. The sinuses should be dilated, and all fragments removed from the cavity in which they lie. When this is done thoroughly, the sinuses will rapidly granulate and close. Partial operations are useless; if but a bit of a bone be allowed to remain, a troublesome fistula will persist.

JOHN BLAND SUTTON.

The works of greatest value on the subject of extra-uterine gestation in the English language are the following:—

CAMPBELL, WILLIAM. *Memoir on Extra-Uterine Gestation.* Edinburgh, 1840. This brochure is useful, as it reveals the slender and unreliable character of the



evidence on which the varieties of extra-uterine gestation were based in the early part of this century.

PARRY, JOHN S. *Extra-Uterine Pregnancy: its Causes, Species, Pathological Anatomy, Clinical History, Diagnosis, Prognosis, and Treatment*. London, 1876. This work is a great improvement on that of Campbell; but like that book, its great defect is the admission, uncriticised, of every reported case as evidence of the existence of the speculative varieties of extra-uterine gestation according to the fancy of the reporter.

TAIT, LAWSON. *Ectopic Gestation*, 1888. This epoch-making brochure is valuable only for the great advance it marks in the surgery of tubal gestation, but for the admirable generalisation enunciated by its author that *probably all forms of ectopic pregnancy have their starting-point in the Fallopian tubes*. This generalisation, subsequently put on an anatomical basis by other workers, has served more than anything else to revolutionise the pathology and surgery of what was formerly termed "pelvic hæmatocele."

#### REFERENCES

1. BARNES. *Trans. Obstet. Soc.* vol. xxiii. p. 170.—2. BERRY HART and CARTER, note *Edinburgh Medical Journal*, vol. xxxiii. 322.—3. BOZEMAN. *New York Med. Journal*, 1884, vol. xl. p. 693.—4. CHAMPNEYS. *Trans. Obstet. Soc.* vol. xix. p. 456.—5. CHESTON. *Medico-Chir. Trans.* vol. v. p. 104.—6. DEZEIMERIS. *Journal de Connaissances, Medico-Chirurgicales*, 1836. Reprinted and translated by Berry Hart in *Obstet. Trans. Edin.* vol. xviii. p. 233, and *Am. Jour. of Obstetrics*, vol. xxix. p. 577.—7. FRANKLIN. *Brit. Med. Journal*, 1894, vol. i. p. 1019.—8. GALABIN. *Trans. Obstet. Soc.* vol. xiii. p. 821.—9. GODSON. *Proc. Med. Soc. London*, vol. vii. p. 390.—10. HERMAN. *Brit. Med. Journal*, 1890, vol. ii. p. 722.—11. JESSOP. *Trans. Obstet. Soc.* vol. xviii. p. 261.—12. KEITH, SKENE. *Obstet. Trans. Edin.* vol. x. p. 92.—13. MALHERBE. *Bull. de la Soc. Anat. de Paris*, t. ix. p. 3.—14. STEVENSON, SINCLAIR. *Trans. Obstet. Soc.* vol. xxxii. p. 216.—15. STONHAM. *Trans. Path. Soc.* vol. xxxviii. p. 445.—16. TAYLOR. *Trans. Obstet. Soc.* vol. xxxiii. p. 115.—17. TILT. *Trans. Obstet. Soc.* 1873, vol. xv. p. 155.—18. WORRALL. *Med. Press and Circular*, 1891, vol. i. p. 296.—19. WALTER. *Brit. Med. Journal*, 1892, vol. ii. p. 732.—20. WEBSTER, CLARENCE. *Ectopic Pregnancy*, 1895.—21. WILLIAMS, SIR JOHN. *Trans. Obstet. Soc.* vol. xxix. p. 490.

J. B. S.

---

#### PELVIC INFLAMMATION

In dealing with so wide a subject as pelvic inflammation it is necessary at the outset to state the precise meaning which, so far as the present article is concerned, those words are intended to convey. The phrase, as here used, must be understood to include the two affections known as pelvic cellulitis and pelvic peritonitis. The inflammation of the several viscera contained in the female pelvis will be described in other parts of this work, and will only be referred to here in so far as they are concerned in the pathological processes that lead to the two diseases just named.

Several writers of distinction, amongst whom Virchow and Matthews Duncan may be specially mentioned, have named the inflammations now about to be considered "perimetritis" and "parametritis": the former name was used by them to signify inflammation of the pelvic peritoneum;

the latter to signify inflammation of the pelvic connective tissue. These terms have not been adopted in the following article, for several reasons of which only two or three need be given. Firstly, the words *perineuritis* and *parametritis* are so nearly alike that their use may introduce an additional and quite unnecessary element of confusion into a subject that, for the beginner at any rate, is already sufficiently beset with difficulties: secondly, these terms imply a difference in the anatomical relations of the peritoneum and of the connective tissue to the uterus which does not really exist; the pelvic connective tissue and pelvic peritoneum are in equally close contact with the uterus. It is inaccurate and misleading, therefore, to speak of an inflammation of the one tissue as being an inflammation around the uterus, and an inflammation of the other as being an inflammation near it. Thirdly, the words *perimetritis* and *parametritis* describe, in terms of the uterus alone, affections which often involve all parts of the pelvis, and are not necessarily uterine even in their origin.

Until recent years the views generally held and taught with reference to pelvic inflammation were exceedingly vague and unsatisfactory; in many respects indeed erroneous. Clinical observation was so seldom brought to the test of the operating theatre and the post-mortem room that certain erroneous inferences drawn from facts observed at the bedside remained year after year uncorrected by actual inspection and dissection, and were thus accepted as articles of current professional belief. Almost every attack of pelvic inflammation was believed to be a cellulitis; and if, on vaginal examination, a hard, irregular, fixed mass could be felt on one or both sides of the uterus, the diagnosis of cellulitis was held to be established beyond cavil. It is true that many years ago Aran and Bernutz, in France, combated this view, and the latter proved by a large mass of post-mortem evidence the true nature of the majority of these swellings: but the influence of their writings upon the current belief and teaching was for many years inappreciable. It was not, indeed, until the practice of abdominal surgery became extended, and opportunities of comparing the physical signs with the actual conditions became thereby more frequent, that the truth of their main contention began to be generally recognised and accepted. The knowledge thus gained from abdominal surgery on the one hand, and the advances made in our knowledge of the anatomy of the female pelvis — especially by the study of frozen sections — on the other, have completely revolutionised our views of pelvic inflammation; and the light shed by modern research on the inflammatory process itself has tended still further in the same direction. Whosoever now undertakes to give an account of pelvic inflammation must consider it from an entirely new stand-point, both as regards its etiology, its pathology, its diagnosis, and its treatment. It is not pretended that our knowledge is as yet sufficiently complete to make it possible to deal with any of these points in an entirely satisfactory manner. All we can attempt at present is to indicate the lines on which the subject must be studied henceforth, and to eliminate from the descrip-

tion all that modern investigation has shown to be ill-founded or erroneous.

After these introductory remarks on the general subject of pelvic inflammation, we may proceed to consider its two great varieties.

### PELVIC CELLULITIS

(SYNONYMS. — *Parametritis* ; *Periuterine phlegmon*)

**Definition.** — Pelvic cellulitis is an inflammation of the pelvic connective tissue. Such an inflammation may be primary or secondary; that is, it may originate in the connective tissue itself, or it may originate in one of the neighbouring structures and reach the connective tissue by extension. The primary form, which is the one here considered, is an acute infective disease; indeed, it differs in no respect from acute inflammation of the connective tissue in any other part of the body. Chronic pelvic cellulitis is always a secondary affection, complicating inflammation of some other part; it is never the sequel of an acute cellulitis.

**Anatomy.** — The pelvic connective tissue is not a special structure, but is a "portion of a wide system of mesoblastic connective tissue which surrounds the great vessels of the trunk, accompanying their branches from origin to termination, and extending, mainly in the form of perivascular sheaths, to all parts of the body" (Anderson and Makins). In the pelvis the connective tissue is found partly in the form of a loose areolar network, and partly in the more condensed form of fasciæ. It surrounds all the blood-vessels, nerves, and lymphatics, as well as the ureters; and passes, as investing sheaths, to certain of these outside the limits of the pelvic cavity. Below, it is shut off from the perineum and ischio-rectal fossæ by the pelvic fascia. "This strong aponeurosis is attached to the pelvic wall between the pubic bones and bodies of the ischia, along that thickening of the obturator fascia known as the white line. From this it passes as a continuous sheet over the levator ani and coccygeus muscles to the vagina in front, and the rectum and coccyx behind. Behind the pubic symphysis it is closely blended with the vaginal orifice under the name of the triangular ligament. All inflammatory exudation connected with the female genitals above the vulva takes place above this strong fascia" (Keiller). The cellular area of the pelvis, thus bounded below, has for its upper boundary the peritoneum. Here, however, its limitation is less strict, as it is continuous with the subserous connective tissue of the parietal peritoneum of the abdominal cavity. Turning now to the distribution of the pelvic connective tissue we find that, except perhaps over the fundus uteri, it forms a layer under the entire pelvic peritoneum, parietal and visceral. The so-called "ligaments" of the uterus contain a greater or less quantity of it between the peritoneal folds of which they are composed: and in certain special situations it may be said to be abundant; for example, around the supravaginal portion of the cervix uteri, along the base of the broad ligaments,

and between the bladder and the symphysis pubis. In the last-named situation it contains in its meshes a varying quantity of fat.

The office of the connective tissue, in the pelvis as elsewhere, is simply "to connect and support the other tissues, performing thus a passive mechanical function" (Schäfer).

The layer of the connective tissue intervening between the vaginal roof and the peritoneum does not ordinarily measure more than about one-third of an inch in thickness; but the study of frozen sections has shown us that in pregnancy its thickness is greatly increased. The broad ligaments are gradually drawn upwards during the growth and development of the pregnant uterus, until, at the end of pregnancy, they lie in the iliac fossæ, entirely above the brim of the pelvis; and no peritoneum is found dipping into the lateral parts of the pelvis. The space thus vacated by the broad ligaments and the reflections of peritoneum behind and in front of them is filled up by connective tissue, so that the quantity of connective tissue in the pelvis is in the later months of pregnancy enormously increased. This fact, it need scarcely be said, has a most important clinical bearing.

**Etiology.** — Primary pelvic cellulitis is always a result of septic infection. Its most common source is the absorption of septic matter through the lacerations of the cervix uteri and of the upper part of the vagina which occur during labour. Injury to the vagina results from the use of obstetric instruments, especially the forceps, much more frequently than is generally supposed. On many occasions, when examining cases of puerperal pelvic cellulitis seen in consultation, I have discovered wounds of the vagina, entirely unsuspected by the medical practitioner in attendance, which had evidently been caused by the projecting edge of one of the blades of the forceps. Such wounds, if they remain aseptic, readily heal; but it often happens that septic matter finds its way into them, and then pelvic cellulitis results. In rare cases cellulitis may commence in the inner portion of the broad ligament immediately outside the uterus (where the connective tissue of the broad ligament is thickest) from direct infection through the tissues of the uterine wall. Polk and Lewers have each described a case of this kind, verified by post-mortem examination. Other sources of infection are the various surgical manipulations practised on the vagina and cervix. Before the necessity of aseptic precautions was understood and generally acted upon, the most trifling surgical proceedings in these parts were apt to be followed by an attack of cellulitis. Cases thus produced are now happily rare. Septic infection following abortion seldom gives rise to primary pelvic cellulitis, for the simple reason that the cervix uteri and vagina are not exposed to injury; the cervix is not unduly stretched during the passage of the ovum, and the vagina is not wounded by instruments.

Inasmuch as lacerations of the cervix and upper part of the vagina (the parts around which the connective tissue is found in greatest abundance) are the injuries most likely to be followed by cellulitis, it



follows that any surgical operation by which the integrity of these tissues is endangered, such as the removal of large uterine polypi, may, as in the process of parturition, open the way for cellulitic infection. It is obvious that special danger is incurred if, at the time of their expulsion or removal, the polypi are undergoing necrosis.

In connection with the etiology of cellulitis it must be remembered that whenever the connective tissue has been subjected to bruising, as in parturition and the expulsion or removal of large polypi, its power of resistance to the infective process has been thereby diminished; or, in other words, its susceptibility to infection has been increased.

The lymphatics are the channels by which the poison is conveyed to the connective tissue. Hence there is always a certain amount of lymphangitis associated with cellulitis. It is highly probable that the lymphatic glands also are generally implicated, as well as the lymphatic vessels. But as both the lumbar glands, which receive the lymphatics from the broad ligaments and the body of the uterus, and the hypogastric or pelvic glands which receive the lymphatics from the cervix uteri and upper portion of the vagina, are out of reach of the examining finger, we are without direct clinical evidence of glandular enlargement. We know, however, that in acute cellulitis in other regions of the body, where the lymphatic glands are in situations in which they can be examined by the sense of touch, glandular enlargement is invariably found and glandular suppuration is by no means uncommon. Hence, we are justified by analogy in concluding that in pelvic cellulitis a similar condition of things usually obtains. Moreover, cases of cellulitic abscess in the pelvis not unfrequently occur in which the situation of the abscess makes it highly probable that the hypogastric glands are involved in the suppuration.

**Frequency.** — It is not possible at present to give any exact statements as to the frequency of pelvic cellulitis. It can be stated, however, with certainty that, compared with pelvic peritonitis, it is a rare affection.

**Pathological Anatomy.** — Pelvic cellulitis occurs with or without the formation of pus. In the latter case, as in cellulitis elsewhere, there is an exudation of coagulable lymph, with œdema, into the tissue of the infected area, which at first produces increase in bulk without manifest alteration of consistence. Very soon, however, the inflamed tissue becomes stiff and indurated; and at a later stage the hardness is often so marked as to be not inappropriately compared with cartilage. As the patient recovers, the inflammatory exudation gradually undergoes absorption and eventually disappears altogether. When suppuration occurs the result is a true pelvic abscess. Usually there is a single large abscess cavity; but occasionally several abscesses are found in contiguous portions of the cellular area.

**Symptoms.** — Pelvic cellulitis is often ushered in by a rigor. In puerperal cases this usually occurs on the second or third day after delivery, but it may take place later. In non-puerperal cases the interval between the period of infection and the first manifestation of symptoms

seldom exceeds a day or two. It is the occurrence of this rigor or chill, as the initial symptom, that has given rise to the popular but erroneous notion that the disease may be the result of exposure to cold. Simultaneously with the rigor, the temperature rises and the pulse becomes accelerated. Pain seldom occurs unless the inflammation extend to the neighbouring peritoneum. In cases attended with suppuration perhaps the most marked symptom is the progressive emaciation: this is always associated with pallor and with a certain earthy sallowness of the skin which is highly characteristic. The skin over the body generally is harsh and dry and covered with branny scales, the result of fine desquamation. The patient, in severe cases, looks extremely ill. All desire for food is lost. The bowels are ordinarily constipated, though occasionally there is diarrhoea. There is often marked mental depression, with an irritability of disposition that may be quite foreign to the patient's true character. It is most interesting to observe how quickly the symptoms are ameliorated when the pus is evacuated and the tension relieved. Within a few hours the patient's aspect will have undergone an entire change, and her irritability and despondency will have disappeared. If the exudation extend to the connective tissue in the neighbourhood of the psoas and iliacus muscles, and still more, if it involve the connective tissue elements in the substance of these muscles, the patient (in order to relax the muscles) lies with the thigh of the affected side bent upon the trunk and the leg drawn up.

The general symptoms are those of a subacute form of septicæmia; the local symptoms are often so few and indefinite that the existence of an acute inflammatory process within the pelvis may remain for some time unsuspected.

**Physical Signs.** — In the early days of an attack of acute pelvic cellulitis, physical examination gives us but little information. The vagina is hot and tender, and its vessels may be felt pulsating; and that is all. After the lapse of several days the physical signs are those of inflammatory exudation, at first brawny in consistence and afterwards densely hard, in the tissue of the affected area. When the poison has entered through a wound in the cervix, the cervix is found to have lost its normal mobility, and the supravaginal tissues on the affected side are found uniformly tender and more or less hard and unyielding. Owing to their swollen condition they cause a depression of the lateral fornix of the vagina on that side, sometimes completely obliterating it. It is seldom that both sides of the pelvis are equally affected; but it is by no means unusual to find the whole supravaginal portion of the cervix embedded in a thick tender collar of indurated tissue, which more or less completely surrounds it. In the majority of cases the inflammation spreads laterally along the base of the broad ligament of the infected side, and then passes forward to the tissue beneath the reflection of peritoneum on the anterior abdominal wall. It is at this stage that an area of uniform hardness and resistance can be felt in the abdominal wall beneath the muscles. This hardness usually takes the form of a broad band, measuring one and a

half to two inches or more in width, and lying along the upper border of the inner portion of Poupart's ligament. More rarely the area of hardness is confined to the supra-pubic region, whence it may gradually extend upwards even as far as the umbilicus. Sometimes the exudation spreads upwards and outwards from above Poupart's ligament into the iliac fossa, interfering with the action of the psoas and iliacus, and leading the patient to keep the thigh flexed in order to relax these muscles. In some instances the inflammation passes backwards instead of forwards, producing an exudation in the tissue of one or both utero-sacral ligaments, in the tissue surrounding the rectum and in that beneath the peritoneum lining the posterior pelvic wall. In these cases much information can be obtained from a rectal examination, when the rectum will be felt wholly or partially surrounded with a hard belt of exudation. As pelvic cellulitis is at least as common on the left side of the pelvis as on the right, such an implication of the tissue surrounding the rectum is by no means unusual. Meantime there is no swelling in the situation of Douglas' pouch, unless the case be complicated with pelvic peritonitis. When the body of the uterus is the starting-point of the cellulitis, and the broad ligament itself the seat of the exudation, bimanual examination will reveal a hard, smooth, flattened, slightly movable tumour, by the side of the uterus and inseparable from it, occasionally displacing it a little towards the sound side.<sup>1</sup>

When there is no suppuration the exudation becomes absorbed, and, in uncomplicated cases, the hardness gradually disappears, leaving no trace behind.

**Pelvic Abscess.**—In a considerable number of cases of pelvic cellulitis the inflammation is attended with the formation of abscess. The situation of the abscess and the position where it may be expected to point depend, of course, upon the direction in which the inflammatory exudation has extended. Taking the most common case first, — that, namely, where the inflammation is seated in the tissue at the base of the broad ligament, and passes forward beneath the peritoneum as it is reflected on the anterior abdominal wall, forming an area of induration above Poupart's ligament, — the presence of suppuration is manifested by the occurrence of œdema in the skin over the indurated area, which pits on pressure; by the signs of deep-seated fluctuation, and by the eventual pointing of the abscess at a site usually a little above Poupart's ligament. This site can often be detected long before the pus has reached the surface, by passing the tip of the finger carefully over the indurated area, where it can be recognised as a soft depression in the midst of the surrounding hardness. Of twenty-two cases of cellulitic abscess treated at St. Thomas' Hospital during the years 1889–93, the abscess pointed above Poupart's ligament in no fewer than eighteen. Whenever pelvic cellulitis extends in such a direction as to cause an induration in the abdominal wall — whether that induration be in front of the bladder (supra-pubic), or above Poupart's ligament, or over the iliac fossa — it may reasonably be expected that, if an abscess be formed,

<sup>1</sup> An exaggerated importance has been attached to lateral displacement of the uterus as a distinctive sign of pelvic cellulitis; it occurs but rarely, and is of little diagnostic value.



it will point on the external surface of the body at the site of the induration. Unfortunately, pelvic cellulitis, as has already been stated, sometimes extends in a backward instead of in a forward direction, following probably the course of the lymphatics; if, under such circumstances, suppuration occur, the result is less satisfactory: an abscess is then formed beneath the peritoneum covering the back of the pelvis, and, as the contents of such an abscess have no direct access to a free surface, relief is much longer delayed and extensive burrowing is almost inevitable. Extension into the iliac fossa and the loin is more particularly apt to take place when the posterior pelvic wall is thus the seat of an abscess, the abscess pointing either at the iliac crest or above it. Sometimes the pus leaves the pelvis by the sciatic notch, and follows the course of the sciatic and gluteal vessels; in other instances it makes its appearance in Scarpa's triangle, having found its way by the side of the femoral vessels. By whatever route the pus makes its way out of the pelvis it does so by following the track, not of nerves or of tendons, but of the blood-vessels and other parts, such as the ureter, which are accompanied by a prolongation of the connective tissue as they enter or leave the pelvis. It is sometimes stated that a pelvic abscess may follow the course of the psoas muscle; but when matter burrows along the psoas it comes not from a cellulitic abscess, but from dead bone.

The statement, so commonly made, that cellulitic abscesses frequently burst into the rectum, the vagina, and the bladder, appears to rest on very slender foundation. Many of the cases quoted in its support belong to a time when little was known of the pathology of pelvic inflammation, and on reading them in the light of our present knowledge it is easy to see that at least a considerable number of the cases reported as cellulitic abscesses were really cases of intraperitoneal suppuration, originating in suppurative disease either of the Fallopian tubes or the ovaries. There is, however, no anatomical reason why cellulitic abscesses should not occasionally discharge themselves into the rectum, vagina, or even the bladder; and some of the cases on record appear to be genuine examples of such an occurrence.

The usual time for an abscess to point is from the seventh to the twelfth week. The earliest period at which I have known pointing to occur is five weeks, the latest fourteen.

*Diffuse Pelvic Suppuration.*—In connection with this subject of abscess in the pelvic connective tissue I must mention a peculiarly malignant form of pelvic inflammation, occurring for the most part in puerperal women, in which, in addition to other lesions significant of the virulence of the septic infection, there are found after death multiple abscesses in the connective tissue, many of them so small as easily to escape detection unless carefully looked for. This affection has all the characters of phlegmonous erysipelas. The tissues involved are œdematous and of a livid hue; suppurating thrombi are found in the veins, and the lymphatics are seen to be acutely inflamed. In a considerable proportion of the cases the ovaries are found to be in a state of suppuration, and



there is usually evidence of extension of the inflammation to the pelvic peritoneum. Such cases are attended with all the symptoms of septicaemia in its most intense form and are rapidly fatal.

**Diagnosis.** — As pelvic cellulitis is usually unattended with pain, it has often made considerable progress before its presence is suspected. Puerperal women very naturally show a repugnance to vaginal examinations, owing to the tenderness of the external genitals and the presence of the lochia. When the puerperium runs a normal course this feeling is very properly respected, and the medical attendant is justified in abstaining from the infliction of the unnecessary pain and annoyance occasioned by digital examination. But it cannot be too strongly pointed out that the justification for this abstention ceases when symptoms of pyrexia supervene, and when it becomes evident that the ordinary course of recovery is interrupted. A temporary elevation of temperature may, of course, occur from such causes as constipation and the influence of the emotions. As soon, however, as the medical attendant has satisfied himself that the symptoms are not of this transient nature, it becomes his duty, especially if the lochia be offensive, to make a thorough examination not only of the vagina, but of the interior of the uterus which, during the first ten days after delivery, can easily be explored by the bimanual method without resorting to artificial dilatation. If the result of this examination be the discovery of a fragment of placental tissue or a decomposing blood-clot within the uterus he will of course remove it, and adopt suitable measures for cleansing and disinfecting the uterine cavity, with the almost certain prospect of thereby promptly relieving the symptoms. If not, he will have eliminated the most probable cause for the pyrexia, and will, at the same time, have had an opportunity of detecting any swelling or other morbid condition in the tissues surrounding the uterus and vagina. Within a very few days of the onset of the attack the physical signs of pelvic cellulitis become sufficiently well marked to leave no room for doubt as to the diagnosis; and the discovery of a laceration of the cervix or of the vaginal wall will usually indicate the probable channel through which the infection gained an entrance. Frequently one of the earliest signs of cellulitis is an impaired mobility of the cervix, with tenderness and swelling on one side of it. A little later the inflamed tissue becomes stiff, and the stiffness quickly increases into a well-defined hardness. The inflammation may gradually extend all round the upper part of the cervix; or may spread outwards along the base of the broad ligament of the affected side, depressing the lateral fornix of the vagina and sometimes obliterating it. At a later stage the induration will, in the majority of cases, extend to the sub-peritoneal connective tissue above Poupert's ligament, and become evident on external examination as a brawny, tender swelling in that region. The diagnosis of the presence of pus has already been described. When the direction taken by the cellulitis is towards the posterior part of the pelvis, an examination per vaginam of the posterior pelvic wall on both sides will usually

reveal a diffused fulness and hardness on the affected side as compared with the sound side; whilst a rectal examination will, owing to the infiltration of the tissues surrounding the middle portion of the rectum, render the diagnosis still more certain.

In the rarer case of the broad ligament proper being the part affected, the diagnosis is made by finding the mobility of the body of the uterus impaired by the presence of a more or less flattened mass of induration on one side of the body and continuous with it. This mass is capable of a certain amount of movement backwards and forwards when held between the two examining hands. It does not extend into the posterior pelvic fossa.

Except along the plane of tissue between the cervix uteri and the bladder, the cellular area of one side of the pelvis is more or less shut off from direct communication with that of the other side by the close attachment, in the middle line, of the visceral peritoneum to the bladder, fundus uteri, and rectum. Hence pelvic cellulitis is for the most part unilateral.

The differential diagnosis between pelvic cellulitis and pelvic peritonitis will be more conveniently considered when the physical signs of the latter affection have been described. The only other conditions likely to be confounded with pelvic cellulitis are hæmatoma of the broad ligament and myoma of the uterus. In hæmatoma of the broad ligament there is an effusion of blood into the connective tissue of the ligament, which forms a slightly movable, somewhat flattened tumour by the side of the uterus and continuous with it, simulating that rare variety of pelvic cellulitis which affects the broad ligament proper. The history of the case and the absence of symptoms of severe illness will, as a rule, serve sufficiently to distinguish a hæmatoma from an inflammatory condition. Hæmatoma occurs suddenly, either from the rupture of a pregnant tube into the connective tissue between the layers of the mesosalpinx, or from rupture of a varicose vein in the broad ligament. In either case the onset is usually marked by sudden pain and faintness and usually also by an attack of vomiting. In the case of rupture of a pregnant tube one or more menstrual periods will probably have been missed, and attacks of pain will have occurred in the lower part of the abdomen, generally on one side, with slight irregular hæmorrhages from the uterus. The effect of a sudden outpouring of blood into the tissues of the broad ligament, so far as the temperature and pulse are concerned, is transient. Hence when the hæmatoma has existed for a few days the temperature and pulse become normal. The possibility, however, of the hæmatoma becoming infected and undergoing suppuration must be borne in mind. Should this occur, the symptoms will be similar to those of pelvic abscess due to cellulitis.

In regard to myoma of the uterus, it certainly seems extremely unlikely that this disease could ever be mistaken for a cellulitic exudation. Now and then, however, a case occurs in which a myoma

develops itself laterally between the layers of the broad ligament, fixing the uterus and forming a more or less hard tumour directly continuous with it. Should a localised peritonitis take place around such a tumour, or should such a tumour become inflamed or gangrenous, the diagnosis might be attended with considerable difficulty. A myoma in the posterior wall of the uterus could scarcely give rise to misleading signs; large inflammatory exudations into the connective tissue behind the cervix uteri being extremely rare. Similarly, a myoma in the anterior wall of the uterus is not likely to be mistaken for cellulitis, the signs of cellulitic exudation between the bladder and the upper part of the cervix being well marked and highly characteristic.

**Prognosis.**—Except in the diffuse variety of pelvic cellulitis, in which the cellulitis is only a part of a general septic process of the most acute and fatal type, the disease usually terminates in recovery. As soon as the fever subsides the exudation begins to undergo absorption, and under favourable circumstances it will have entirely disappeared in a few weeks. Unlike pelvic peritonitis, cellulitis, when uncomplicated by peritonitis, leaves no unpleasant results such as adhesions or displacements. The recovery is complete. An attack of pelvic cellulitis is therefore no bar to subsequent pregnancy.

If the fever do not subside in the course of five or six weeks suppuration has probably occurred. The duration and progress of the illness will then largely depend on the direction that the pus may take in its efforts to reach the surface. In the large majority of cases the abscess will point above Poupart's ligament, where it can be opened easily and satisfactorily before much burrowing has occurred. These cases almost invariably do well. In the rarer cases, where suppuration occurs at the back of the pelvis, the pus is longer in reaching a surface and is apt to burrow in different directions. Such cases often last a long time and are very trying. They are more apt, too, to be complicated by extensions to the peritoneum.

It is often stated that troublesome sinuses are a not infrequent result of pelvic abscess. I have never myself yet seen a troublesome sinus result from opening a cellulitic abscess in the pelvis on the surface of the body; and I strongly suspect that the cases in which such sinuses have occurred have not been cellulitic abscesses, but suppurating ovarian cysts, or other non-cellulitic forms of pelvic suppuration. Similarly, cellulitic abscesses are said to burst into the rectum, vagina, and bladder, and to form fistulas in consequence. I believe this assertion to be, generally speaking, ill-founded. It must be a very rare occurrence for cellulitic abscesses to open into these organs; the abscesses that commonly open into them are the result of suppuration in the tubes or ovaries. It is easy to understand that such abscesses will not unfrequently be followed by fistula. But under ordinary circumstances a true pelvic abscess, that is, a cellulitic abscess, discharges its contents and disappears.

**Treatment.**—If the views here set forth concerning the uniformly septic origin of pelvic cellulitis be correct, the preventive treatment of the disease may be summed up in a very few words: it will consist in a strict regard to asepsis, or surgical cleanliness, in all midwifery cases and in all surgical manipulations of the female genital organs. If freedom from infection could be ensured to the parturient woman pelvic cellulitis would, for all practical purposes, disappear; and if a similar freedom could be extended to every woman who is submitted to vaginal examination and manipulation the disappearance of the disease, as a primary affection, would be complete.

It is very doubtful whether, when once an attack of pelvic cellulitis has been lighted up, it is possible to modify the course of the disease by any medication, internal or external. In this uncertainty it behoves us at least to be careful not to do our patients any harm. The remedies against the abuse of which I consider it specially desirable to utter a word of warning are opium and the antipyretics. Opium in one form or another is frequently given as a matter of routine. The result is a further disturbance of the already disturbed digestive functions, and an aggravation of one of the principal difficulties with which the physician has to contend, namely, constipation. Opium and morphia should be reserved for cases complicated with peritonitis, and therefore attended with pain; and should be given with the sole object of relieving pain. Similarly, antipyretics (including quinine when administered in large doses) should be reserved for the rare occasions when the temperature is so high as to constitute in itself a source of danger. When there is no special therapeutic indication, a simple saline mixture containing liquor ammoniæ acetatis or potassium citrate, or some acidulated vegetable tonic, will be the safest and most suitable medicine. The state of the bowels should receive the most careful attention. A regular course of aperient medicine at bedtime will almost always be required, and will often need the supplement of a soap-and-water enema in the morning. The patient's comfort will much depend on the care with which fæcal accumulations are avoided. The question of feeding is of equal importance. In the acuter stages a farinaceous diet is proper, but as soon as possible fish or fowl should be given, and a persistence of febrile temperature need be no bar to a meat diet if the patient can take it. The tendency to emaciation calls for generous feeding, and concentrated foods are only to be used when ordinary food cannot be taken.

Local applications to the lower parts of the abdomen are only necessary when induration is to be felt in that situation, or when pain is present. Hot flannel fomentations afford most relief; it is well to alternate them with the application of a thick layer of dry cotton wool, kept in place, if necessary, by a flannel bandage. The application of glycerine and belladonna, at present much in vogue, is of very doubtful value. It is inferior to hot fomentations and poultices as a means of relieving pain.



The hot vaginal douche, administered at a temperature of 110° to 115° F., was highly extolled by Dr. Emmet of New York, who believed it to be exceedingly efficacious in promoting absorption of the inflammatory exudation. Chiefly owing to his persistent advocacy, it has become more popular than any other form of local application; though its remedial effect is very doubtful, it is often a source of comfort to the patient, and if administered gently can at any rate do no harm. Vaginal tampons of glycerine have for many years been in favour as an additional means of hastening the disappearance of inflammatory thickening. More recently, tampons soaked in a 15 per cent or 20 per cent solution of ichthyol in glycerine have been recommended for the same purpose. The remedial value of these applications is probably very slight.

When matter forms the case is to be dealt with on recognised surgical principles; the abscess should be opened as soon as fluctuation is detected, or there is the faintest indication of pointing. In ordinary cases the drainage tube is required for a very few days only. In the great majority of cases the incision will be made externally. In this form of pelvic suppuration abdominal section is, in my experience, entirely uncalled for. Should the abscess point in the vagina, it must of course be opened there. Most, however, of the fluctuating swellings felt through the vaginal roof are not cellulitic abscesses, but come into quite a different category.

Before concluding the subject of treatment, I desire to call attention to the need, in those cases in which the patient lies day after day with the knee and thigh flexed, of guarding against permanent contraction of the knee-joint. This distressing result may generally be avoided by instructing the nurse to place her hand beneath the heel, to raise it sufficiently high to straighten the knee, and to hold it in this position for a few minutes twice a day.

#### CHRONIC PELVIC CELLULITIS

Chronic pelvic cellulitis does not exist as an independent affection, or as a sequel to the acute disease above described; but it occurs occasionally as a secondary result of purulent salpingitis or other intrapelvic suppurative inflammation. It only involves the parts immediately contiguous to the inflamed structures, and never gives rise to the broad band of induration in the lower part of the anterior wall of the abdomen so common in the primary affection.

The induration to which it does give rise introduces, of course, for the time being, an element of obscurity into the diagnosis of deep-seated inflammatory lesions in the pelvis; but it generally subsides under the influence of rest, thus at the same time establishing its true nature, and removing the difficulty interposed in the way of a satisfactory bimanual examination.

This variety of pelvic cellulitis is seldom or never attended with

cellulitic abscess; it is characterised chiefly by œdema and small-celled infiltration of the connective tissue concerned.

### PELVIC PERITONITIS

(SYNONYMS. — *Perimetritis*, *Perisalpingitis*, *Perioophoritis*)

**Definition and Nature.** — Pelvic peritonitis is an inflammation of that portion of the peritoneum which is situated within the pelvis. It is a much more common affection than pelvic cellulitis, and is perhaps met with more frequently than any other inflammatory disease in the pelvis. In the vast majority of cases (if not indeed in all) it is an infective process, due either to the presence of micro-organisms or to their chemical products. Its action may, nevertheless, be regarded as in the main beneficial. Not only is it, in itself, an effort on the part of the organism to resist and do battle with the invading foe, but, by erecting barriers around the diseased area, it tends to narrow and confine the field of infection and thus to shield the neighbouring structures from damage.

In his Lettsomian Lectures for 1894, delivered before the Medical Society of London, Mr. Frederick Treves emphasises very forcibly this view of the nature of peritonitis. “The purpose of peritonitis,” he says, “is towards the saving of life, and not towards the destruction of it.” This purpose is not always fulfilled. The poison may be too virulent, or may be present in too great quantity for the inflammatory process to cope with it successfully; or again the inflammatory process itself may be excessive, and, like most agencies that are powerful for good, may occasionally be powerful also for harm.

**Etiology.** — Pelvic peritonitis probably never occurs otherwise than as a result or complication of some pre-existing disease within the pelvis. Not unfrequently, however, it is the first indication of the presence of such disease; for the symptoms of peritonitis are for the most part acute and of a character to compel attention, whereas those of the original disease are often so slight as to be scarcely noticeable. Hence it happens that in many cases, until an operation or an autopsy discloses the disease which was its starting-point, all we can say with certainty is that pelvic peritonitis is present. Under such circumstances it is not surprising that pelvic peritonitis was for a long time, and by some persons is still regarded as being, occasionally at least, a primary idiopathic inflammation, the result of such simple causes as injury, exposure to cold, or the sudden arrest of menstruation.

As our knowledge advances it is becoming more and more doubtful whether this is ever the case. It is true that instances occur in which no pre-existing disease is discovered; but the number of such cases is diminishing so rapidly that the failure to discover it in a particular case is much more likely to be due to imperfections in our knowledge and in our powers of observation than to its non-existence.

*Salpingitis and its Complications.*—In the vast majority of cases, pelvic peritonitis in woman is the result of inflammation of the Fallopian tube. Other causes will be pointed out presently; this, being much the most common one, claims our first and chief attention.

The mucous membrane lining the Fallopian tube is, at the abdominal ostium of the tube, continuous with the peritoneum; whilst at the inner or uterine end of the tube it is continuous with the mucous membrane lining the uterine cavity. Thus there is direct communication between the uterus and vagina on the one hand and the peritoneum on the other. Owing to the continuity of its lining membrane with that of the uterus and vagina, the Fallopian tube is exposed to constant risk of infection, and the tendency of acute infective endometritis, whether septic, gonorrhœal, or tubercular is to spread to and involve the tube. From the mere fact of the direct continuity of the structures concerned the extension of the infection to the peritoneum is rendered almost inevitable; but the risk is still further increased by the peculiar anatomical position of the Fallopian tube in the human subject. No other mucous canal in the body is similarly situated. When, for example, the mucous membrane lining the uterus is inflamed, the patency of the cervical canal provides a natural outlet for the morbid secretions. In the Fallopian tube there is no such natural outlet. The uterine end of the tube, under normal circumstances, has a lumen only just large enough to admit a fine bristle. It will, therefore, be readily understood that a very slight amount of swelling of the mucous membrane, such as is probably inseparable from the mildest inflammatory attack, may block this end completely. Hence, as an outlet for inflammatory secretions, the uterine orifice may be regarded as practically non-existent. If there is, therefore, any outlet for them at all it is into the peritoneal cavity. It is this absence of a suitable outlet for the morbid secretions of the tube, and the continuity of the lining membrane of the tube with the peritoneum, that together give to the inflammatory affections of the tube such an exceptional importance, and make pelvic peritonitis so constant a sequel of salpingitis.

There are other ways, besides direct extension and the escape of inflammatory products, in which pelvic peritonitis may result from inflammation of the Fallopian tube. It is by no means an uncommon result of the inflammatory process for the abdominal ostium of the tube to become sealed by adhesions, or by inflammatory changes in the fimbriæ. The morbid secretions are then retained within the tube, which thus becomes a centre around which the inflammatory process spreads through the wall of the tube to the neighbouring tissues, and chiefly to the peritoneum. Even if this extension do not immediately occur, the diseased tube is constantly liable to fresh inflammatory attacks from slight causes, and these may at any time extend to the peritoneum. If the pent-up secretion consist of pus, as is frequently the case, not only is the liability to recurrent attacks of pelvic peritonitis more marked than when the accumulation is merely serous or muco-purulent, but there is the added

danger of ulceration of the tube wall with the possibility of the pus escaping into the peritoneum by perforation.

Sometimes the inflamed Fallopian tube infects the ovary, causing it to suppurate, and a fresh source of danger to the peritoneum is thus produced. The Fallopian tube must still be regarded as the starting-point; but instead of affecting the peritoneum directly, it does so in this instance indirectly, through the medium of the inflamed ovary. Under such circumstances the inflamed tube and ovary may both act as the sources of pelvic peritonitis; but, occasionally, the tube, after infecting the ovary, so far recovers as to be itself no longer a centre of fresh mischief, and an attack of peritonitis may then be due directly to the ovarian condition. Secondary infection of the ovary appears to be particularly apt to occur when the ovary is already the seat of cystic disease; and simple abscess of the ovary is much less common than suppuration in an ovarian cyst. The most usual mode of infection is through the cyst wall, at a spot where it has become adherent to the diseased tube. Occasionally, however, infection takes place by an ulcerative process, which allows the contents of the suppurating tube to escape suddenly by perforation into the interior of the cyst. This is the ordinary way in which a *tubo-ovarian abscess* is formed. Such a sudden extension of the suppurative process invariably provokes a fresh outburst of peritonitis, the attack being usually much more severe and dangerous than any that has preceded it. A still more alarming peritonitis is set up when the contents of a suppurating tube or of a suppurating ovary escape by ulceration into the peritoneal cavity. Fortunately it very seldom happens that such an escape takes place primarily into the general peritoneal cavity, so as to cause a diffuse suppurative peritonitis: the escape usually occurs into a space limited by adhesions, and results in an intra-peritoneal abscess. An abscess so formed rapidly enlarges, and, if allowed to go on and the patient survive, eventually bursts, according to its situation, either into some neighbouring canal or viscus, or into the general peritoneal cavity, or on the surface of the body.

Although suppuration of an ovarian cyst is usually the result of infection from an inflamed Fallopian tube, it may occur independently of tubal disease. There is reason to believe, for example, that the infection is occasionally due to the contiguity of the rectum or some other portion of the intestine. This is especially likely to happen when the tissues have been injured by bruising, as in the process of parturition. Peritonitis may also result from twisting of the pedicle of an ovarian tumour. Experience shows that this accident — with consequent strangulation, intra-cystic hæmorrhage and inflammation or necrosis, according to the degree of strangulation — is particularly apt to take place during parturition. Hence, whenever puerperal peritonitis arises, the possibility of its source in this accident should be borne in mind. That an ovarian tumour was not previously known to exist by no means excludes it from consideration.

*New Growths, etc.* — Apart from these complications, any new growth



in the pelvis may, by its mere presence, set up peritonitis. The frequency of adhesions in ordinary cystic disease of the ovary is sufficient proof of this. But tumours vary considerably in their tendency to excite the inflammatory process in the surrounding peritoneum. Thus it is exceptional to meet with peritonitis as a result of the presence of uterine myomas, even if very large, unless the tumours have undergone degenerative changes; whilst papilloma of the ovary and tube, dermoids of the ovary and malignant disease, are seldom found without evidence of more or less extensive peritonitis.

*Severe Septicæmia.*— When septic infection of a severe type follows abortion, parturition, or surgical manipulations of the female genital organs, instead of limiting itself to an attack upon the mucous lining of the genital canal, it may spread along the lymphatics and the veins, and so give rise to a diffuse septic infection of the pelvis, involving, amongst other tissues, the peritoneum. In some cases a peritonitis so produced remains localised in the pelvis; but much more frequently the inflammation becomes general, and an acute general septic peritonitis is the result. Associated with this condition is usually found a diffuse pelvic suppuration of a peculiarly malignant form, a condition already described in the chapter on pelvic cellulitis.

*Injury.*— Both the teachings of bacteriology and clinical experience tend to show that injury alone will not cause peritonitis; and that it is only when the hand or instrument with which the injury is inflicted is surgically unclean that the inflammatory process is excited. In illustration of this, we may contrast the rarity with which evil effects follow the most extensive injuries to the peritoneum inflicted during a difficult and severe case of abdominal section—say for the removal of a tumour in the broad ligament—or the accidental perforation of the unimpregnated uterus by the curette or uterine sound, with the terrible results that so frequently follow bungling attempts to produce criminal abortion. In fatal cases of the latter kind it is generally found that death has resulted from acute septic peritonitis, with a punctured wound of the uterus or adjacent tissues for its starting-point. It cannot be doubted that the question is entirely one of infection. The operator in such cases is almost invariably found to have been either very ignorant or very reckless,—in either case an extremely unlikely person to have adopted precautions against infection.

Allusion has already been made to another way in which injury may determine an attack of pelvic peritonitis. The shape and size of the normal female pelvis are such as to fit it for the passage of a normally sized child at the full term, but are not such as to enable it to accommodate anything beyond that. If therefore the pelvic space is encroached upon by a new growth, the size of which cannot be reduced or its position altered—as, for example, by a small adherent multilocular ovarian tumour—an obstacle is offered which either prevents parturition by the natural passages altogether, or renders it possible only at the expense of much bruising of the tumour. Should the latter event occur, the vitality,

and, with it, the resisting power of the tumour are lowered, so that it falls an easy prey to pathogenetic micro-organisms, whether they attack it from the uterus in front or the rectum in the rear. In this way the occasional occurrence of puerperal peritonitis from suppurative inflammation of an incarcerated and contused ovarian cyst is to be explained.

*Pelvic Cellulitis.* — As pelvic cellulitis may be, and very frequently is, secondary to other forms of pelvic inflammation, so pelvic peritonitis may be the result of the spread of the inflammatory process from the adjacent connective tissue. This is especially apt to take place when the cellulitis is attended with suppuration, or when the portion of connective tissue chiefly involved is that which lies in the posterior part of the pelvis.

*Pelvic Hæmatocele.* — The slighter hæmorrhages that occur within the pelvic peritoneum, and especially those which take place from the open fimbriated end of the Fallopian tube in the early stages of tubal pregnancy, usually result in the formation of a pelvic hæmatocele. The effused blood becomes shut off from the general peritoneal cavity, partly by the firm coagulation of its outer layer, but chiefly by the glueing together of the parts around it by adhesive peritonitis. In this way the collection of blood becomes roofed in by adherent omentum and coils of intestine, the peritonitis thus serving to limit the effusion and conducing to its ultimate absorption.

*Disease of the Appendix Vermiformis.* — Although it is not within the scope of this work to deal with diseases other than those which are peculiar to women, no account of the etiology of pelvic peritonitis would be satisfactory that did not include some reference to one at least of the causes that are common to both sexes, namely, disease of the appendix vermiformis. The normal position of the appendix is in the iliac fossa, above the brim of the pelvis; but instances are by no means uncommon in which the appendix is found lying within the pelvis, and it therefore becomes necessary when investigating a case of pelvic peritonitis, especially if the right side be the part chiefly affected, to bear in mind the possibility that the inflammation may be of intestinal origin. There is another way in which the diagnosis may be obscured. It has been shown, by the study of frozen sections, that towards the latter part of pregnancy the uterine appendages and broad ligaments are elevated completely out of the true pelvis; the consequence is that they are brought at that time into close contiguity with the cæcum and its appendix. If the appendix, then, happens to become diseased, or, being already diseased, happens to set up an attack of peritonitis during this temporary displacement of parts, the pelvic peritoneum, broad ligament, and uterine appendages will almost certainly be involved and the difficulty of diagnosis thereby greatly increased.

It is obvious that, within the limits of space at our disposal, it would be impossible to furnish anything like an exhaustive account of the etiology of pelvic peritonitis. The bacteriology, for example, has of necessity been entirely omitted. I hope, however, that what has been

said will convey some idea of the relative importance and comparative frequency of the principal causes of pelvic peritonitis, and will serve to emphasise the fact that pelvic peritonitis is no longer to be regarded as a disease in itself, but as an indication of the existence of some other disease, the nature of which it is our first duty at the bedside to discover.

**Pathological Anatomy.**—The earliest change produced in the peritoneum by inflammation is hyperæmia, with cloudy swelling of the endothelium. The membrane loses its normal smooth, shining appearance, and becomes dull, dry, and slightly roughened. Plastic lymph is then poured out on the surface, and this leads to the rapid formation of adhesions between adjacent surfaces. The adhesions thus formed are the most characteristic feature of pelvic peritonitis. In cases where the inflammation is recurrent fresh adhesions take place during each attack, so that there are often in the same patient adhesions of different ages and varying density. In addition to the effusion of lymph there is also effusion of serum: this serum tends to accumulate principally in the pouch of Douglas; but it also forms collections of fluid in different parts of the pelvis, wherever spaces intervene amongst the adhesions.<sup>1</sup> Thus are formed distinct and limited swellings which often simulate a true cyst. One of the earliest results of the adhesive process is to roof in the contents of the pelvis at the level of the brim, and to shut off the cavity of the pelvis from that of the general peritoneum. When the quantity of plastic lymph thrown out is at all considerable, the lymph coagulates on the surface of the peritoneum, forming a distinct coating which can be peeled off like a membrane. Lymph coagula are also formed in the effused serum, and may be found either floating in the fluid or deposited on the surrounding surfaces. As its fluid portion becomes absorbed, this coating of lymph stiffens the peritoneum and, with the induration of the subjacent cellular tissue due to secondary cellulitis, contributes to produce the hardness which is one of the most striking of the physical signs of pelvic peritonitis in its later stages. The intraperitoneal collections of serum are gradually absorbed; but the adhesions continue for a long time, and many of them become permanent, with the result of producing more or less serious interference with the functions of the viscera involved. The evidences of inflammation are usually most strongly marked around the fimbriated end of the Fallopian tube, and diminish in intensity as the distance from that point increases. This is exactly what our knowledge of the etiology of pelvic peritonitis would lead us to expect. Inasmuch as the large majority of cases of pelvic peritonitis originate in salpingitis, it is not surprising that the firmest adhesions are met with at the mouth of the tube binding the fimbriæ to the part with which they happened at the time to be in contact. Where the peritonitis has not originated in salpingitis, but in some other morbid condition, such as a suppurating ovary or a diseased appendix vermiformis, the inflammation is most

<sup>1</sup> Peritonitis attended with the effusion of serum has been quite unnecessarily described as a special variety of pelvic inflammation under the name of serous perimetritis.



severe, and the adhesions are most dense at the seat of origin, wherever that may be.

It is usual for the Fallopian tube, when inflamed, to sink below its ordinary position, so that its abdominal ostium lies either upon the floor of the lateral fossa of the pelvis or in the pouch of Douglas. In other cases the tube, after embracing the ovary, becomes adherent by its fimbriated end either to the ovary itself or to a part of the posterior surface of the broad ligament internal to the ovary. In many instances the two tubes meet, and their distal ends become adherent to each other behind the supravaginal portion of the cervix uteri in the middle line. Less frequently the direction taken by the tube is different on the two sides: one tube is bent upon itself, with the usual horse-shoe curve, and terminates behind the broad ligament or upper part of the cervix uteri; the other tube runs at first sharply forwards, then doubles upon itself, forming a loop or knuckle, and finally runs outwards and slightly backwards to terminate against the lateral wall of the pelvis, and become adherent to it by its abdominal opening. In puerperal cases where, as has been already pointed out, the tube is lifted out of the pelvis by the development of the pregnant uterus, the mouth of the tube, and hence the chief area of the peritoneal inflammation, will be found at or near the pelvic brim close to the border of the *psaos* muscle.

Wherever the mouth of the tube may be, the ovary is almost invariably found implicated in the inflammatory process, and adherent over its entire surface — partly to the diseased tube, partly to the back of the broad ligament. In cases of old standing it is very common to find the ovary the seat of incipient cystic disease, and considerably enlarged. There is strong reason to believe, though there is as yet no definite proof, that this condition of the ovary is occasionally the result of changes induced by the surrounding peritonitis. Whenever the tube and ovary are bound to each other, the intervening portion of broad ligament — called the *mesosalpinx* — if it have not already been opened out and appropriated as part of the covering of the expanded tube, usually becomes creased, folded, and so intimately bound up with the adhesions as for all practical purposes to be effaced.

In chronic cases, it is very usual to find the peritoneum in the neighbourhood of the adherent mass lifted up here and there by circumscribed collections of serous fluid in the meshes of the delicate connective tissue immediately subjacent to the peritoneum. These swellings vary in size from that of a pea to that of a large orange. They are of no pathological importance, but often introduce difficulties in the way of accurate diagnosis. The mass formed by the agglutination of the tube, ovary, and broad ligament, is usually found to have become adherent posteriorly, to the peritoneum covering the posterior pelvic wall and the rectum. Sometimes one or more coils of intestine and a portion of the omentum intervene and become implicated in the entangled mass. The body of the uterus is sometimes involved in the adhesions and at other times is entirely free; its position remains normal unless the tube or ovary, or



both, besides being adherent, are enlarged — the former by inflammatory, the latter by cystic changes — when the uterus is displaced to the opposite side and more or less rotated on its longitudinal axis. The roofing in of the pelvis is generally effected by adhesion of intestine and omentum to the horizontal rami of the pubes below, to each other, and to the matted contents of the pelvis posteriorly.

When the disease causing the peritonitis is purulent in character the peritonitis itself is also apt to be purulent; and instead of accumulations of serum amongst the adhesions collections of pus are formed — intraperitoneal abscesses. More rarely general suppurative peritonitis results; this only occurs in septic cases of exceptional virulence, or from the sudden bursting into the peritoneal cavity of collections of pus in the Fallopian tube or in the ovary. Intraperitoneal abscesses may be single or multiple, and may begin in several different ways. The most usual way is for the purulent contents of a suppurating Fallopian tube to be discharged from the abdominal ostium of the tube into Douglas' pouch or into a space bounded by adhesions. Sometimes both tubes discharge their contents into a common receptacle, and as the mouth of the tube is usually directed downwards and backwards, this receptacle is generally the pouch of Douglas. Here a tense fluctuating swelling is formed, easily felt through the depressed vaginal roof and also through the anterior rectal wall, which is bulged backwards so as to cause a more or less serious obstruction of that portion of the bowel. The discharge, however, may take place when the tube is not lying with its mouth in the usual direction, as, for example, when the salpingitis follows delivery, and the tube is situated at or above the pelvic brim as a result of the drawing up of the parts during the development of the pregnant uterus. The resulting abscess will then obviously be formed, not primarily in Douglas' pouch (though it may subsequently find its way there) but in a higher part of the pelvis, generally in the neighbourhood of the pelvic brim.

Purulent salpingitis, however, not uncommonly results in the sealing up of the abdominal ostium of the tube; the pus is then confined within the closed tube, forming a pyosalpinx. Under these circumstances an intraperitoneal abscess may be formed either by infection of the peritoneum through the walls of the tube, or by the bursting of the pyosalpinx from ulceration commencing within, or by the spread of the infective process to the ovary, causing it to suppurate and to become in its turn a fresh focus of infection and the seat of a fresh collection of pus liable at any moment to ulcerate and burst.

An intraperitoneal abscess, walled in by adherent viscera, may either run an acute course or may remain for some time latent, giving few or no indications of its presence. Sooner or later, however, if the patient survive, one of two things must happen: either the abscess gradually dries up and disappears (which there is good reason to believe does occasionally occur in the case of small abscesses with non-virulent contents), or its walls undergo ulceration, and its contents make their escape either into the bowel — usually the rectum or the sigmoid flexure

of the colon — or, more rarely, into the vagina, the bladder, or the general cavity of the peritoneum; or through some part of the abdominal wall. The common way of escape for the contents of an intraperitoneal abscess is undoubtedly by the bowel, as that for the contents of a cellulitic abscess is through the abdominal wall. Other routes than these may, in both cases, be regarded as exceptional.

Intraperitoneal abscesses in the pelvis differ from cellulitic abscesses in the same part in another very important respect. For whilst the latter as a rule quickly disappear when once they have found an outlet, the former are apt to discharge their contents imperfectly, so that troublesome sinuses are formed which for months and even for years, may remain a source of annoyance if not of serious ill-health.

Amongst the secondary changes that occur as a consequence of these inflammatory processes, there are one or two of such importance as to call for special mention. When the salpingitis is unilateral, the peritonitis frequently extends to the other side of the pelvis, involving the healthy uterine appendages of that side in a mass of adhesions. Under such circumstances closure of the abdominal ostium of the healthy tube is apt to occur, and to be followed by the development of a hydrosalpinx in the manner described in detail by Mr. Doran in the article on "Diseases of the Fallopian Tube." Hæmatosalpinx, as a complication of salpingitis, is much more rare. In the great majority of cases, effusions of blood within the tube, and hæmatoceles of tubal origin, are the consequences of tubal gestation; but now and then they occur as incidents in the inflammatory processes above described quite independently of gestation.

**Symptoms.** — An attack of pelvic peritonitis is characterised by pain in the lower part of the abdomen, usually sudden in its onset, and for the first few hours severe in character; by fever, as indicated by rise of temperature and increased rapidity of pulse, and very often by vomiting. There is usually more or less intestinal distension, sometimes general, sometimes localised. After the acute pain has subsided, movement is attended with suffering owing to the tenderness of the inflamed parts. The symptoms are usually sufficiently severe to oblige the patient to remain in bed for a time; and the length of time that the patient was confined to bed is the best rough test at our disposal of the severity of a past attack. Rigors are infrequent, except where the pelvic peritonitis is part of a diffuse septic inflammation, or where the symptoms are due to the intraperitoneal bursting of an abscess, as in the case of rupture of a pyosalpinx or a suppurating ovary. Constipation is generally met with; and pain preceding defæcation and during micturition occurs if the inflamed part be contiguous to the rectum in the one case and the bladder in the other.

In subacute and chronic cases, pain in the back and inability to undergo physical exertion are the most common and may be the only symptoms. Menstruation usually becomes more profuse than natural,

and is often accompanied with pain. Trifling causes, such as slight over-exertion or exposure to cold, readily provoke localised acute attacks of inflammation in patients with chronic pelvic peritonitis.

Such recurrent attacks are especially apt to occur when the chronic pelvic peritonitis is kept alive by the presence of pelvic suppuration. Indeed, recurrent localised attacks of peritonitis afford a much more valuable guide to the diagnosis of pus in the pelvis than does the temperature. In twelve out of thirty of my own operation cases in which suppuration was present, the temperature before operation was absolutely normal; and in only twelve of the remainder was the temperature distinctly and persistently febrile.

In severe cases, however, attended with suppuration, patients become ill and emaciated, and entirely incapacitated for work or for exertion of any kind. In the worst cases of all the patient becomes a bedridden invalid. Between the two extremes, the one patient who is wholly confined to bed and the other who is scarcely conscious of anything wrong except during the occasional acute attacks that serve to betray the existence of some deep-seated lesion, there are, of course, all possible gradations. The amount of suffering endured by a patient with chronic inflammatory disease of the uterine appendages must always largely depend, not only on the extent and nature of the disease, but also upon the class of life to which she belongs, and the demands made upon her activity.

During an acute attack of pelvic peritonitis, the patient lies on her back and is least uncomfortable when the knees are drawn up. There is extreme tenderness to the touch over the lower part of the abdomen, with rigidity of the abdominal wall over the affected parts. This rigidity is due to contraction of the muscles, and is not under the control of the patient's will. In exceptional cases a definite swelling can be detected on abdominal palpation. This is the case when the inflamed appendages happen to be situated above the pelvic brim; or when the attack is due to suppuration in an ovarian cyst of sufficiently large size to be reached on abdominal examination; or when there is an encysted exudation of serum or of pus in front of the uterus, or a sufficiently extensive exudation posteriorly to push the uterus forwards against the abdominal wall. As a rule, however, there is no swelling to be discovered, and any noticeable enlargement is merely that produced by local distension of the intestine with flatus. On vaginal examination the parts will, at this stage, be too sensitive to permit a satisfactory investigation of the lateral regions of the pelvis. If there be any depression of the vaginal roof, it will be not lateral, but central; and will be due to an encysted effusion of fluid, serous or purulent, in the pouch of Douglas, distending the sac, obliterating the posterior vaginal fornix, and displacing the uterus forwards. There may be tenderness and a sense of resistance on pressing the fingers upwards into one or both lateral fornices; but, unless there be a cystic ovary or other cause of unusual enlargement on the affected side, it will not be possible to map out any definite swelling in the posterior fossæ of the pelvis until the acute symptoms have

subsided. When this event has occurred, a careful bimanual examination, conducted if possible while the patient is under the influence of an anæsthetic, will reveal in the posterior fossa of the pelvis on one or both sides of the uterus the presence of a fixed, irregular, tender swelling. This begins at the uterine cornu as a cylindrical body about equal in thickness to a lead pencil, and is capable of being rolled between the fingers; it runs outwards for a short distance, and then becomes somewhat suddenly thicker, curves upon itself, completely reversing its direction, and finally ends behind the cervix uteri in the pouch of Douglas. This swelling consists of the thickened Fallopian tube, adherent to the ovary, embracing it in the concavity of its curve, and surrounded on all sides by thickened and adherent peritoneum. The uterus is seldom pushed aside by this mass, and does not, as in the case of cellulitis of the broad ligament, appear to form a part of it. The uterus may, however, have been retroverted or retroflexed to begin with, when it will have become adherent in its abnormal position; or it may be pushed forwards as a whole by an effusion of serum or pus in the pouch of Douglas. Lateral displacement only occurs when there is either exceptional enlargement of the diseased tube or of the ovary. Under these circumstances, in addition to the pushing over of the uterus towards the opposite side, there may be some bulging of the swelling into the vagina, causing a depression of the lateral fornix; a condition which, generally speaking, is much more characteristic of pelvic cellulitis than of pelvic peritonitis. When the lateral swelling in the latter affection is large enough to produce these displacements, the cause will, in the majority of cases, be found to be enlargement of the ovary from cystic disease; a not very uncommon complication of inflammation of the uterine appendages.

The shape and consistence of the lateral swelling vary considerably in different cases, and even in the different stages of the same case. Sometimes the tube is soft and sausage shaped; this is specially apt to be the case when the abdominal ostium is occluded and the tube is uniformly distended. Sometimes the distension affects the outer end only, giving the mass the shape of a retort. In other cases the tube becomes irregularly distended from sacculation, or is thrown into complicated folds, forming sharp knuckles or prominences here and there as it bends upon itself, and presenting to the examining finger sausage-like convolutions with intervening grooves. The consistence of the mass depends partly upon the extent to which the walls of the tube have become thickened, and partly upon the amount of induration of the surrounding peritoneum. This latter is found to be most marked when the examination is made soon after an acute attack. As the patient recovers from the immediate effects of such an attack, the hardness of the peritoneum gradually diminishes, and the outlines of the adherent appendages become more easily defined. In cases attended with suppuration or complicated with effusions of serum or pus amongst the peritoneal adhesions, the swelling is rendered still more irregular in shape and unequal in consistence. In some parts it may be possible to obtain clear evidence of fluctuation.



**Diagnosis.** — The only conditions likely to be mistaken for pelvic peritonitis are pelvic cellulitis and pelvic hæmatocele.

*Pelvic Cellulitis.* — Some help in the diagnosis from cellulitis may be obtained from the etiology of the two affections. Pelvic cellulitis is, to begin with, a much rarer disease than pelvic peritonitis: its origin is exclusively septic, never gonorrhœal or tubercular; it is essentially a disease of the puerperium, due to absorption of septic matter through wounds of the cervix uteri and vagina occasioned during the process of parturition. Over-stretching and laceration of the cervix being likely to occur only when the child is of full size, it is rare to find pelvic cellulitis following abortion and premature labour. In the cases where pelvic inflammation is the result of the absorption of septic matter during surgical manipulations, it will be found that it only takes the form of cellulitis where the manipulations have involved the integrity of the cervical tissues. Where the manipulations have been intra-uterine and unattended with injury to the cervix, the poison is absorbed not by the connective tissue, but by the endometrium, the resulting inflammation extending along the mucous membrane of the Fallopian tube to the peritoneum.

It is generally held, and with truth, that the presence of acute pain points to the pelvic inflammation being peritoneal. Cellulitis, when uncomplicated, is a disease unattended with pain, or at any rate with severe pain. The sudden onset, then, of acute pain in an attack of pelvic inflammation is an indication that the inflammation has reached the peritoneum. After the acute stage has passed, however, the pain of pelvic peritonitis is only felt in standing or walking, though the tenderness remains, and is apparent on vaginal examination and on coitus.

It must, nevertheless, be remembered that pain in the pelvis, as elsewhere, is a most misleading symptom, and is seldom as severe in cases of actual disease as it is in many neurotic conditions in which there is no obvious lesion, inflammatory or other.

In both cellulitis and peritonitis there may be and generally is a swelling in the lateral regions of the pelvis; but, whereas in cellulitis the swelling is usually unilateral, smooth, uniform, attended with depression and fixation of the vaginal roof, and of stony hardness, in peritonitis it is more often bilateral than unilateral, and instead of being smooth and of uniform consistence, and conveying the impression of being due to an exudation in the tissues immediately subjacent to the vaginal wall, it is irregular in outline, unequal in consistence, and is ascertained on bimanual examination to be situated in the fossa behind the broad ligament with a certain thickness of normal tissue intervening between it and the examining finger. Another point of distinction is that in cellulitis the cervix uteri is apt to be surrounded by a hard, thick collar in which it is immovably set; whilst in peritonitis there is no such girdle of indurated tissue, and the impairment of the mobility of the cervix is never so complete. Further, in cellulitis there is no inflammatory effusion or any kind of swelling in Douglas' pouch; whereas in peritonitis there is

almost always either a certain amount of distension from inflammatory effusion (serous or purulent), or the pouch is felt to be occupied by a hard, irregular, fixed swelling, adherent to the supravaginal portion of the cervix uteri, and continuous with the fixed irregular mass situated in one or both lateral fossæ.

A similar difference exists in the conditions found on rectal examination. In cellulitis the rectum will often be felt to be surrounded, wholly or partially, by a belt of exudation of stony hardness, fixing the coats of the bowel at that part and narrowing the calibre of the canal. In peritonitis, on the other hand, any effusion within reach from the rectum will be in Douglas' pouch; it will be less hard, it will not affect the mobility of the coats of the bowel to the same extent, and, though it may press on the bowel in front, it will not encroach upon it laterally.

When the broad ligament itself is the seat of a cellutic exudation, bimanual examination will reveal a hard, smooth, flattened tumour by the side of and continuous with the uterus, and sometimes displacing it slightly to the opposite side. This tumour can be moved backwards and forwards within certain narrow limits. The swelling caused by the inflamed and adherent appendages in pelvic peritonitis is, on the contrary, of irregular contour, and is not continuous with the uterus, but on a plane behind it, and is quite fixed.

When the cellutic exudation has reached the sub-peritoneal connective tissue of the anterior abdominal wall, it gives rise to a smooth, hard swelling in the deeper layers of the wall itself, either immediately above Poupart's ligament, or, more rarely, in the suprapubic region. This swelling has a well-defined upper boundary and is quite characteristic, there being nothing in the least like it in pelvic peritonitis.

In non-suppurative cellulitis the exudation becomes entirely absorbed, and the hardness disappears without leaving any trace, except where the exudation is in the substance of the broad ligament, when there may be some contraction with more or less dragging over of the uterus to the affected side. In favourable cases of peritonitis the hardness and thickening become much less marked; but the viscera once adherent are apt to remain so for an indefinite time, and there is generally to be felt a soft, irregular mass in the posterior part of the pelvis for the remainder of the patient's life, with some amount of uterine fixation and possibly of displacement.

Finally, suppuration in pelvic cellulitis generally takes the form of an abscess pointing on the surface of the abdominal wall a little above Poupart's ligament, and quickly disappearing when once it has found an outlet; whereas in pelvic peritonitis, if suppuration exist, it is either in the Fallopian tube (pyosalpinx), or in the ovary, or amongst the peritoneal adhesions (intraperitoneal abscess): its favourite outlet is into the large bowel or some other internal part, and it is apt to lead to the establishment of troublesome sinuses.

*Pelvic Hæmatocele.*—The diagnosis of an effusion of blood in the pouch of Douglas from effusions of serum or pus depends largely upon the

clinical history of the case, and upon the transient character of the febrile disturbance in pelvic hæmatocele. As pelvic hæmatocele, in the vast majority of cases, is a complication of tubal pregnancy, there will usually be a history of one or two menstrual periods having been passed, and of a sudden attack of pain, accompanied with nausea or vomiting and an alarming feeling of faintness. The patient will have a blanched appearance, the pallor being greater than the slight uterine hæmorrhage usually present is sufficient to account for. The effusion, at first distinctly fluid, soon acquires a doughy consistence from partial clotting; and, later, becomes diminished in bulk and harder, as the peripheral portion of the effused blood forms a dense fibrinous wall. The possibility, however, of the hæmatocele undergoing suppuration must not be lost sight of. The signs and symptoms in such an event will be similar to those of an intraperitoneal abscess with septicæmia.

**Prognosis.**—The prognosis in pelvic peritonitis is much less favourable than in pelvic cellulitis. Not only is the mortality higher, but the after-effects, in those patients who recover, are apt to be much more troublesome, and are not unfrequently of a character sufficiently serious to entail a life of chronic invalidism. The disease which caused the peritonitis still remains when the acute attack of peritoneal inflammation has subsided, and constitutes a centre around which fresh attacks of inflammation are continually liable to occur, either from changes in the diseased tissues themselves, or from external agencies (such as exposure to cold and damp) of a nature insufficient to excite inflammation in healthy tissues, but capable of doing so only too readily when the power of resistance of the tissues is lowered by disease.

The tendency to recurrent attacks of peritonitis is more marked in cases where the underlying disease is accompanied by pus either in the form of pyosalpinx, suppurating ovary, or intraperitoneal abscess.

The damage done to the uterus, ovaries, and Fallopian tubes during an attack of pelvic peritonitis, especially that done to the tube by the closure, adhesion, or displacement of its abdominal ostium, frequently has the effect of producing sterility; and even if the gradual absorption of morbid adhesions permit the occurrence of conception, the continuance of gestation to full term may be rendered impossible owing to interference with the normal expansion of the pregnant uterus. It is not possible, however, in any given case to be certain that pregnancy cannot thenceforth occur; for experience shows that, even after the most violent peritonitis, the parts may recover themselves sufficiently to permit not only of subsequent conception, but of normal delivery at term. The discreet practitioner, therefore, will always hesitate to commit himself to the opinion that his patient cannot again bear children.

Another not infrequent effect of pelvic peritonitis is permanent interference with the normal action of the bowels due to the implication of intestine in the pelvic adhesions. Occasionally still more serious results follow these adhesions in the form of acute intestinal obstruction.



It must be remembered, nevertheless, that pelvic peritonitis may result in complete recovery, and that the prognosis must be determined by the special circumstances of each individual case.

**Treatment.** — 1. *Preventive.* — Inasmuch as in the large majority of non-puerperal cases, pelvic peritonitis is due to gonorrhœal salpingitis, the prophylactic treatment consists in destroying the gonorrhœal infection before it has extended to parts beyond the reach of local applications. Gonorrhœa in the woman is still regarded in this country as a comparatively unimportant affection, though it probably destroys the health of a larger number of women than does even the much more dreaded poison of syphilis. As a rule, the earlier indications of the disease pass unregarded: they are attended with but little pain, often with none when the urethra is not involved, and the significance of the purulent discharge is not realised. Hence it frequently happens that medical advice is not sought until the infection has had time to inflict serious, and sometimes life-long damage on important organs. And even if advice be obtained earlier, the disease is not always regarded seriously or vigorous treatment adopted. It does not come within the scope of this article to describe the symptoms and treatment of acute gonorrhœa in the female. It must suffice to point out that a latent gonorrhœa in the male, supposed to have been cured, may be roused by marriage into renewed activity; and that a purulent vaginal discharge, especially if in a recently married woman, should always be looked upon with grave suspicion, and its treatment undertaken with a due sense of responsibility.

The preventive treatment of pelvic peritonitis due to septic salpingitis — which includes (1) nearly all the non-puerperal cases that are not accounted for by gonorrhœa, and (2) all the cases that are traceable to abortion, parturition, and surgical manipulation — consists in a rigid adherence to the rules of aseptic surgery and midwifery, especially as regards the thorough and even elaborate disinfection of hands, instruments, and sponges. By this means only can we hope, in the midst of our varied work, to avoid becoming the occasional carriers of septic infection.

In those who have once been the subject of pelvic peritonitis, it becomes important to avoid such causes as are likely to provoke a relapse. The utmost care, for example, should be exercised to avoid exposure to cold and damp, especially during the menstrual period; and over-exertion should at all times be guarded against. Prolonged standing appears to be attended with consequences quite as disastrous as excessive exercise, and should therefore be avoided with equal determination. It is not often necessary for patients in whom, notwithstanding the existence of chronic inflammatory disease of the uterine appendages, there is no active peritonitis present, to be condemned to lie in bed and lead an invalid's life; but it is nevertheless essential to insist upon their observance during each day of definite periods of rest in the recumbent posture. It will greatly conduce to the formation of regular habits of this kind for the medical attendant to draw up a few simple but definite rules for his



patient's guidance, and strongly insist on their being diligently carried out. Scarcely less important than the rigorous avoidance of over-fatigue, is the need for constant attention to the state of the bowels. Intestinal adhesions have the almost invariable effect of producing habitual constipation with a tendency to fæcal accumulation, a condition highly favourable to the development and migration through the coats of the bowel of pathogenetic micro-organisms. Hence no effort should be spared, by means of suitable aperients, supplemented, if necessary, by enemata of glycerine or soap and water, to overcome in these patients any tendency to intestinal inaction, and to ensure a thorough emptying of the larger bowel every day.

2. *Medical.* — The medical treatment of pelvic peritonitis consists in very much the same measures as those recommended for the relief of pelvic cellulitis, with the important difference, that whereas opium and its derivatives are never needed in uncomplicated cellulitis, they may be necessary in pelvic peritonitis in order to relieve the acute pain. Even then, however, their administration should be regarded as an unavoidable evil, and should be discontinued at the earliest possible moment. The constipating effects of the opium or morphia should be promptly obviated, all prejudices to the contrary notwithstanding, by efficient aperients or enemata, or both. The accumulation of scybala is much more powerful for harm than the action of purgative medicine, and there should be no hesitation as to the choice of the lesser evil.

Rest in bed is, of course, essential during an acute attack. The diet should be restricted, if not to liquid food, at any rate to food of the simplest and most digestible character, which should be taken at regular intervals so as to allow adequate time for digestion. Pain should be relieved by the application of hot flannel fomentations, and distension by enemata. Should the patient be tormented with thirst the frequent sipping of hot (not lukewarm) water will do more to alleviate it than either the continual sucking of ice or the drinking of effervescing waters. There is no reason for withholding an occasional draught of cold water if the patient long for it. If an enema fail to afford adequate relief to the bowels there need be no hesitation in administering a full dose of castor oil (the best of all aperients for the purpose if it can be retained), calomel, or magnesium sulphate.

The state of the pulse, which in peritonitis is ordinarily a much truer guide to the condition of the patient than the temperature, will indicate when stimulants are needed. If the pulse show signs of flagging — that is of becoming thin, feeble, and intermittent — brandy or whisky should be given in defined and measured doses diluted with five or six times the quantity of water, and the effect carefully watched with a view to the increase or diminution of the dose as may be required. Stimulants should not be allowed, however, to take the place of food, but should be given as far as possible with food. Any tendency to collapse, indicated by coldness of the extremities, sunken features, flickering pulse, and sub-normal temperature, should be further combated by the application of

hot water bottles and the subcutaneous injection of strychnia. Of still greater importance is it to bear in mind the intensely depressing effect of intestinal distension, and to adopt means for enabling the patient from time to time to expel accumulated flatus. Nothing answers the purpose so well as small soap-and-water clysters, which, if necessary, may be frequently repeated. The introduction of a soft india-rubber rectal tube is also often of great service; the tube may be left in for a quarter of an hour at a time if its presence is not a serious annoyance to the patient. Turning the patient on to her side is another, sometimes singularly effectual, means of assisting in the passage of flatus.

*Surgical.*—Surgical measures are not often called for during an acute attack of pelvic peritonitis. When, however, Douglas' pouch is tense from fluid distension, forming a swelling more or less globular in shape, and encroaching both on the vagina and rectum, there can be no hesitation as to the propriety of making an opening through the vaginal roof. Even should the inflammatory effusion prove to be serous only, the mere removal of tension will give great relief. If, on the other hand, the swelling prove to have been an intraperitoneal abscess, such timely interference will not only afford immediate relief to the more urgent symptoms, but will prevent the bursting of the abscess into the rectum, with the possible results of incomplete evacuation and the establishment of a troublesome sinus.

With this exception it is usually wise to defer surgical intervention until the acute symptoms have subsided, and until an opportunity has been afforded of making a thorough bimanual examination, and of arriving at as near an approach to a correct diagnosis as the circumstances of the case permit. If the attack is the first the patient has had, and if the swelling, usually to be found in one or both posterior quadrants of the pelvis, be of so moderate a size as not to be incompatible with the existence of a non-purulent inflammation of the uterine appendages, the case is obviously not one in which operative interference should, for the moment at any rate, be recommended. If, on the other hand, the patient have had similar attacks previously, and if the swelling have attained such dimensions as to make it fairly certain that in the midst of it there is either an occluded and distended Fallopian tube or an ovary enlarged by cystic growth, the indications for the removal of the disease are perfectly clear. Such a mass, with a history of recurrent attacks of peritonitis, almost invariably means the presence of pus; and where pus is there is no remedy worthy of the name except such as is offered by surgery. Between these two extreme instances there are, of course, cases presenting all gradations; and it is impossible to lay down detailed rules as to the conditions that justify operative measures and those that do not. Every case must be decided on its own merits, and according to the class of life to which the patient belongs. A woman from the labouring class cannot afford to spend several months of her life as an invalid, if there be a quicker way to recovery; whereas one who, with ample means, has no necessity for leading an active life, will be perfectly justified in not

submitting to operation until treatment by prolonged rest has been thoroughly carried out and has failed to effect a cure.

When operation has been decided upon, the method of operating still remains to be determined. Abdominal section, being the older and more generally adopted method, will be first described. An aperient having been administered on the previous day, and an enema early in the morning of the day of operation, and the skin of the abdominal wall having been thoroughly disinfected in the manner usual before all abdominal operations, the patient is placed on the operating table either in the ordinary or in the Trendelenburg position (the latter affording the operator a better view of the pelvic contents), and an incision from  $2\frac{1}{2}$  in. to 3 in. long is made in the middle line, ending about an inch above the summit of the symphysis pubis. The operator must be alive to the possibility of adhesions between the intestine and the under surface of the anterior abdominal wall, and he must proceed carefully as he approaches the peritoneal cavity. Usually, on opening the cavity, the omentum is found drawn down so as to cover in the contents of the pelvis anteriorly, and to have contracted adhesions to the peritoneum as it becomes reflected on the anterior abdominal wall, as well as on the uterus and other pelvic viscera. The first step is to separate these adhesions sufficiently to allow the omentum (and any coils of small intestine which may have become adherent to it) to be drawn upwards, or to one side, so as to expose the matted contents of the pelvis behind it. Guided chiefly, if not indeed entirely, by the sense of touch (unless the patient be in the Trendelenburg posture, when he may be aided in his manipulations by the sense of sight), the operator now endeavours, with the tips of the first two fingers of his left hand, to enucleate the diseased uterine appendages from their adherent surroundings. His first landmark is the body of the uterus, which is sometimes free and sometimes implicated in the adherent mass. In the latter case identification may be difficult, and it may be necessary for an assistant to pass one or two fingers into the vagina and to elevate the uterus by pressure on the cervix. When the fundus uteri has thus been identified, the Fallopian tube (on the diseased side if only one side is affected) is to be traced outwards from the uterine cornu, and made to serve as a guide in searching for the planes of adhesion. If the Fallopian tube, which is often normal in size and consistence for the first inch or so, turns quickly backwards and becomes lost in the adherent mass, the safest way of commencing the separation of adhesions is by keeping the fingers close to the posterior surface of the uterus, and tracing the adherent mass downwards into Douglas' pouch. During the manipulations necessary in separating the mass from the walls of the pouch, including the anterior wall of the rectum, it is often desirable for an assistant to pass a forefinger into the rectum; partly to facilitate the separation by steadying the bowel, and partly to enable the operator to know exactly where the bowel is and when he is in dangerous proximity to it. The separation of adhesions in Douglas' pouch is very often the most difficult part of the operation. When this has been effected the tips of the fingers are to be insinuated



beneath the mass, and the separation is to be continued posteriorly from below upwards. When the mass has been cleared from its posterior and inferior attachments to the uterus and to the uterine appendages of the opposite side, there still remain the adhesions to the back of the broad ligament which has usually become more or less so folded over the diseased parts as to form a deeply concave surface on what is, anatomically, its posterior aspect. It is from this concave surface that the mass has now to be separated in order to allow of its being brought up into view, and to permit of the transfixion of the broad ligament below it. The detachment should be effected by working from below upwards, and should be continued until all adhesions have been separated and the ovary and tube remain attached to the uterus and broad ligament by their anatomical connections only. The pedicle is tied and divided as in the operation of removal of the normal uterine appendages for uterine myoma. The appendages of the other side are now to be examined: if they are found diseased they should be removed; if merely adherent the operator may content himself with separating adhesions.

It often happens that during the manipulations just described there is an escape of pus. This is not necessarily due to any fault of the operator; it is usually the inevitable result of separating adhesions around the mouth of a suppurating and adherent tube, or of enucleating a suppurating and adherent ovary whose wall is ulcerated and on the point of bursting. Fortunately, it is only when the pus is unusually virulent that serious harm results from its escape.

Sometimes it becomes obvious during the operation that persistence in the separation of adhesions would expose the patient to unjustifiable risk, either from unduly prolonging the operation, or from the danger of injuring the surrounding viscera. This is specially apt to occur in the case of suppurating ovarian cysts. The operator will find, however, that the cases in which it becomes necessary for him to desist from attempts at entire removal, and to content himself with emptying and draining the suppurating cavity, will diminish as his experience increases. The separation of adhesions to parts of the intestine other than the rectum should be undertaken, whenever practicable, with the parts well in view; and any injury sustained by the bowel during the process should be repaired at once. One of the chief risks of the operation is the liability of mistaking thickened and adherent intestine for an inflamed Fallopian tube. The risk is best obviated by rigidly following the rule of identifying the tube by tracing it from its uterine end outwards, before commencing to separate adhesions.

Whenever it is obvious that the ovary, notwithstanding the adhesions with which it is surrounded, is itself free from disease, it is good practice not to remove it. If even one ovary can be preserved it will prevent the arrest of the menstrual function, and so will save the patient from the discomforts that attend the premature induction of the menopause.

The rule to remove only such parts as are diseased is a sound one: but in the case of tubal disease, where the gross lesion is limited to one



side, the apparently healthy tube of the opposite side should always be carefully examined. If pus exude from it on pressure the proper course is to remove the tube, notwithstanding the absence of thickening of its walls or other obvious sign of disease. It not unfrequently happens that the tube opposite to that which is chiefly affected, though not actually diseased, has become transformed into a retention cyst (hydrosalpinx) by occlusion of its abdominal ostium by peritonitis. In such a case either the tube should be removed, or its contents should be evacuated and a portion of its wall excised.

Every care should be taken during this operation to avoid opening the general peritoneal cavity, if it be possible. The toilet of the peritoneum, after the operation has been completed, should be effected, if necessary, by plentiful douching with hot water (temp. 105° F.) rather than by the vigorous use of the sponge or any of its substitutes. The insertion of a drainage tube is a point that must be left to the judgment of the operator in each individual case. The use of the drainage tube (or strip of gauze which is its equivalent) tends to diminish in frequency as experience increases.

With regard to other matters that concern the technique of this operation, in common with that of abdominal operations in general, the reader is referred to the articles on pelvic surgery. One point, however, in connection with the closing of the abdominal incision may be here mentioned. It has been found greatly to lessen the risk of hernia if, before tying the silk-worm gut sutures that pass through the entire thickness of the abdominal wall, the edges of the sheath of the rectus muscle are brought carefully into apposition by means of a continuous catgut suture. This is preferable to suturing the abdominal wall in layers, which method is apt to leave, between the various layers, interspaces that facilitate the lodgment of serous and other inflammatory effusions.

The after-treatment differs in no respect from that of other abdominal operations.

Within the last few years another method of operating in these cases has come into rivalry with that by abdominal section. This newer operation — first proposed and carried out by Péan in 1886, and since popularised, though in the face of much opposition, by the earnest advocacy of Segond and others — consists in the removal of the uterus through the vagina, supplemented or not, according to circumstances, by the removal of the diseased uterine appendages. It is argued by the supporters of this method that the return of pelvic pain and tenderness, met with in certain cases after the removal of diseased uterine appendages by abdominal section, is due to the fact that the uterus, the original source of all the trouble, is left behind. By the removal of the uterus through the vagina in the first instance, it is maintained that not only is the attack made upon the original seat of the inflammation, but that so excellent a channel is established for drainage that abscess cavities, whether in the tubes or ovaries, or amongst the peritoneal adhesions, can be readily evacuated. Thus, in many cases, it is said to be un-

necessary to proceed to the removal of the diseased appendages themselves. The operation, though its precise position and value have not yet been settled, has now been adopted by a sufficiently large number of influential operators to have established for itself a claim to the serious consideration of all who are interested in the advance of gynæcological surgery.

The first steps of the operation are much the same as in the ordinary operation of vaginal hysterectomy. The patient is prepared by the administration, for several days before the operation, of vaginal douches of solution of corrosive sublimate  $\frac{1}{2000}$ , and by the usual purge and enema a few hours before the operation is to take place.

At the time of operation the patient is placed in the lithotomy position, and four large vaginal retractors (preferably those of Péan) are introduced — one anteriorly, one posteriorly, and one on each side. An assistant on the left side takes charge of two of these, and one on the right of the other two. The cervix is drawn down by means of a volsella and a circular incision made, the incision being nearer the os externum anteriorly than posteriorly, where it may be half an inch above it. In order to give additional room two lateral incisions are now made in the vaginal wall, each about two-thirds of an inch long, running outwards from the circular incision and parallel with the lower border of the broad ligament. The tip of the anterior retractor being now placed in the wound, the bladder and cervix are separated, as far as is practicable, by means of successive snips with the blunt-pointed curved scissors. The scissors are held with the concavity of the curve towards the uterus, so as to avoid the bladder and keep as near to the uterus as possible. The attachments of the cervix posteriorly are now divided, partly by the scissors and partly by the finger, a retractor again being used to pull back the liberated tissue. The next step is to secure by ligature or forceps the lowermost inch of the broad ligament including the uterine artery. This is done by gliding the forefinger of the left hand outward over the anterior surface of the cervix towards the base of the broad ligament, pushing aside the ureter and penetrating between the anterior peritoneal fold and the ligament proper. The same having been done behind, the lowermost inch of the broad ligament is grasped between the fingers and secured by ligature or clamp-forceps. The attachments of the ligament to the uterus are now divided, close to the uterine tissue, to a height corresponding with that of the section secured. The opposite side is dealt with in the same way. The cervix is then slit up on each side so as to divide it into two flaps, anterior and posterior. The posterior flap is cut off, the anterior is seized with strong forceps and drawn well down, and a further separation of the bladder is effected. The stump having been secured against retraction by seizing it with a "bullet-traction" forceps above the line of amputation, the anterior cervical flap is now cut off. The next stage of the operation consists in the removal piecemeal — by morcellation as it is technically termed — of the anterior wall of the uterus. The stump being pulled down by means

of a traction forceps inserted into each side, the uterus is still further separated from the bladder, and small pieces, extending through the entire thickness of the anterior uterine wall, are removed with scissors or knife by a succession of vertical or oblique sections in the middle line. The forceps are successively re-inserted higher up, the uterus is further drawn down and set free, and the morcellation is repeated, until the peritoneal cavity is reached. The fundus uteri now descends sufficiently to allow of its being hooked down by the operator's finger and everted. Such adhesions as exist posteriorly can be seen and separated, and the upper portion of each broad ligament is then secured by one or more ligatures or by forceps, and the separation of the uterus completed. To facilitate this part of the operation some surgeons divide the uterine stump longitudinally and deal with each half separately.

The advantage of morcellation is "that the operator sees exactly what is being done, step by step." If, during the separation of adhesions, pus is seen to escape, the opening into the pus cavity is enlarged by the operator's finger, the cavity is washed out, and the operation resumed. When it is possible to separate the adhesions, the inflamed uterine appendages should be gently pulled down into the vagina, ligatured or clamped, and removed. If the tubes present themselves as large coils distended with pus, the surrounding parts are protected by means of small mounted sponges, and the tubes are opened with the knife in such a way that the contents escape into the vagina without soiling the peritoneum. The edges of the opening are seized with forceps to guard against retraction, and the cavity is irrigated with solution of corrosive sublimate. The tubes should then, if possible, be removed by enucleation with the fingers. If this be found impracticable, they may be left to drain and undergo atrophy. Search should be made with the fingers for any out-lying abscesses, in order that they may be opened and drained. Where the inflamed appendages are situated high up, and are so densely adherent that they cannot be drawn down into view, their separation has to be effected, if effected at all, by the aid of the sense of touch as in the older operation.

Many modifications of the operation have been introduced, but the above account embraces the leading features of the method practised by the most successful operators.

The dressings of the wound are the same as in ordinary vaginal hysterectomy. Iodoform gauze should be packed lightly into any pus cavities that have been left, and removed with the tampons in six days. If clamps have been used, they must be removed in forty-eight hours. An enema is administered on the third day, and from that time nourishing food is given.<sup>1</sup>

It is claimed for this operation that, whilst its mortality is no higher,

<sup>1</sup> The above account is for the most part abridged from the admirable description of the operation contained in a paper by Dr. Edgar Garceau, entitled "Vaginal Hysterectomy as done in France," in the *American Journal of Obstetrics*, March 1895, to which and to the writings of Segond, Riehelot, Jacobs, Leopold, A. Martin, and Landau, the reader is referred for fuller details.

and perhaps even less high than that of abdominal section (undertaken for the same object) it enables the operator to see better what he is doing; it is attended with less shock; it ensures far better drainage; and it does away with the liability to ventral hernia and to troublesome sinuses in the line of incision. It is also urged that inasmuch as the uterus was the seat of the original lesion, and may become the source of re-infection, its removal must be a distinct gain.

The validity of most of these claims need not be questioned; but there are some points in the essential feature of the operation — namely, the removal of the uterus — that do not appear to have received adequate consideration. To remove an organ because its lining membrane is inflamed can scarcely be accepted as coming within the domain of legitimate surgery, unless it can be shown (1) that the inflammation does not tend to subside spontaneously; (2) that there is no other efficient means of treatment, and (3) that the retention of the organ is likely to be a source of greater danger than the operation undertaken for its removal. In all these respects the uterus is in a different position from the Fallopian tube, and an operation that would be perfectly justifiable in the case of an inflamed tube would not necessarily be justifiable in the case of an inflamed uterus. The uterus has, in its cervical canal, a natural outlet for its morbid secretions. The tube has no such natural outlet; its morbid secretions either become pent up in the closed tube, or escape through the abdominal ostium into the peritoneum. In either case they are retained within the body, and hinder the natural process of recovery, which, in the case of the uterus, is carried on without any such impediment. Again, in regard to accessibility for local treatment, the uterus and the Fallopian tube are on a totally different footing; the interior of the uterus is easily within reach, its lining membrane can be swabbed, douched, and curetted at will. The Fallopian tube, on the contrary, is beyond the reach of all these therapeutic measures. We have no means, such as we have in the case of the uterus, of facilitating the natural process of cure by local treatment.

As to the possibility of the uterus becoming a source of re-infection, it must be remembered that although it is of course possible, after the removal of the appendages, for the uterus to re-infect the peritoneum and become a source of fresh mischief, there is no actual evidence that this has happened. The danger is purely hypothetical. On the other hand, there is abundant evidence to show that the uterus may become perfectly sound. Thus, instances are by no means infrequent in which removal of the inflamed appendages for disease limited to one side has been followed by pregnancy, the best proof the uterus could give of the soundness of its condition and the completeness of its cure.

The conclusion to be drawn from these considerations is that the indiscriminate removal of the uterus in all cases of operation for inflammatory disease of the appendages is unjustifiable, and that the vaginal operation ought, at any rate, never to be undertaken unless it be certain that the appendages of both sides are seriously involved in



the disease, and that conception and pregnancy would be practically impossible.

Even apart, however, from this fundamental question of the propriety of removing the uterus, the admitted advantages of the newer operation are not without counterbalancing disadvantages. The operation is one of great difficulty and cannot always be completed. It sometimes happens, indeed, that, after the uterus has been extirpated, it is necessary to perform abdominal section in order to remove the adnexa. Again, there is greater danger than in the abdominal operation of injuring the bladder and the ureter, and probably also the rectum. It has been said that another of the special risks of the vaginal operation is hæmorrhage; but this is a danger to be eliminated by an improved technique.

If, however, the vaginal operation proves in its results to be superior to the abdominal operation, no merely theoretical considerations ought to prevent or will prevent its gradual adoption. The time has not yet arrived for pronouncing a final judgment on the merits of the two operations, or (if, as seems likely, both of them eventually find a legitimate and permanent place in operative gynæcology) for drawing up a formal and authoritative statement of the respective indications for the one operation or the other. In the meantime there can be no doubt that the vaginal operation is at present growing in favour, and that amongst recent converts are to be found men whose recognised sobriety of judgment compels attention to their views.

There still remains another class of cases in which operative interference is occasionally attended with signal benefit, that, namely, in which much suffering and more or less disablement are caused not by definite inflammatory changes in the tube or ovary, but by peritonitic adhesions. The salpingitis that originally started the pelvic peritonitis may have subsided so that there may no longer be any definite swelling in the sides of the pelvis, and yet the peritonitis may have left the pelvic viscera matted together by adhesions of such a kind as to condemn the patient to a life of invalidism. In a large number of these cases the uterus is fixed in a position of retro-displacement. Under these circumstances separation of the adhesions and permanent restoration of the uterus to its normal position often succeed in removing the symptoms and restoring the patient to health.

As in the operation for the removal of the diseased appendages, there are two principal methods of operating from which to choose; namely, abdominal section and operation per vaginam. In the former, an incision of sufficient length to admit of two fingers is made in the middle line, terminating an inch above the pubes. The uterus and its appendages are carefully liberated from their adhesions, and the uterus, having been lifted up into its normal position, is secured in that position either by suturing the anterior surface of the uterus to the abdominal wall (ventro-fixation) or by inserting a Hodge's pessary into the vagina.

In a certain small number of cases in which there are no formidable adhesions between the body of the uterus and the bladder, and in which

the posterior adhesions are not very firm or very extensive, the separation of the adhesions and the fixation of the uterus in its normal position can be accomplished per vaginam by Dührssen's operation of anterior colpotomy. This operation consists in drawing down the cervix, separating the bladder, and dividing the utero-vesical fold of the peritoneum. Access to the peritoneal cavity is thus obtained through the anterior vaginal fornix.<sup>1</sup> Two or three fingers are then passed up, the fundus is seized and drawn forwards, adhesions are carefully broken down, the pelvic viscera are liberated, and, finally, the uterus is secured in its normal position of anteversion by the procedure known as vaginal fixation. At the close of the operation the peritoneal and vaginal wounds are closed by means of continuous catgut sutures.

The separation of peritonitic adhesions in the pelvis can occasionally be effected, without operation, by the manipulative methods associated respectively with the names of B. S. Schultze and Thure Brandt. But these methods have not found favour in this country, nor are they likely to do so. The objections to them are too obvious to need discussion.

CHARLES J. CULLINGWORTH.

#### REFERENCES

1. ANDERSON, W., and MAKINS, G. H. "The Planes of Subperitoneal and Subpleural Connective Tissue, with their Extensions," *Journal of Anatomy and Physiology*, vol. xxv, part 1, Oct. 1890, p. 78.—2. ARAN, F. A. *Leçons cliniques sur les maladies de l'utérus et ses annexes*, pp. 569-750. Paris, 1858.—3. BANDL, L. "Krankheiten der Tuben, der Ligamente, des Beckenperitoneum und des Beckenbindegewebes," *Deutsche Chirurgie*; herausg. von Billroth und Luecke, Lieferung 59. Stuttgart, 1886.—4. BERNUTZ, G., and GOUPIL, E. *Clinical Memoirs on the Diseases of Women*. Transl. and edit. by A. Meadows, 2 vols. New Syd. Soc. Lond., 1866-67.—5. BYFORD, H. T. "Inflammatory Lesions of the Pelvic Peritoneum and Connective Tissue," *Clinical Gynæcology by American authors*. Edit. by Keating & Coe, vol. i. Edin. 1895, pp. 400-460.—6. CHAMPNEYS, F. H. "On the Removal of the Uterine Appendages," *St. Bartholomew's Hosp. Reports*, vol. xxix. for 1893, pp. 45-62.—7. CULLINGWORTH, C. J. "The Etiological Importance of Gonorrhœa in Relation to some of the more common Diseases of Women," *Brit. Med. Journ.* July 20, 1889.—8. *Ibid.* "On the Differential Diagnosis of Pelvic Inflammations in the Female," *Brit. Med. Journ.* Dec. 27, 1890.—9. *Ibid.* "The Value of Abdominal Section in certain Cases of Pelvic Peritonitis," *Trans. Obst. Soc. Lond.* vol. xxxiv. for 1892, pp. 254-429.—10. *Ibid.* "On Pelvic Peritonitis in the Female, and the Pathological Importance of the Fallopian Tubes in Connection therewith," *Brit. Med. Journ.* Aug. 12, 1893.—11. *Ibid.* "On Pelvic Abscess," *Birmingham Med. Review*, Nov. 1893.—12. *Ibid.* "Three Cases of Pelvic

<sup>1</sup> The operation will be found described in detail in Dührssen's *Manual of Gynæcological Practice*, translated by Taylor and Edge. London, Lewis, 1895, pp. 54 *et seq.* Though it finds its most frequent and useful application in the cases above referred to, the operation can be utilised for many other purposes, such, for example, as the removal of small pedunculated subperitoneal myomata, of small and not too adherent tumours of the ovary, of tubal gestation-sacs, and of diseased uterine appendages when these can be drawn into the vagina. The advantages of this over the abdominal operation are that it is less dangerous, and that, owing to the position of the scar, adhesions and hernia of the intestine and omentum are avoided. Its scope, however, is limited, inasmuch as it is only applicable to cases where the cervix can be drawn down to the vaginal entrance, and where, if there is any mass to be removed, the size of the mass does not much, if at all, exceed that of the fist.

Inflammation attended with Abscess of the Ovary," *Trans. Obst. Soc. Lond.* vol. xxxvi. for 1894, pp. 277-296.—13. CUSHING, E. W. "The Pathology and Diagnosis of so-called Pelvic Cellulitis," *Annals of Gynecology*, Boston, U. S. A. March 1889.—14. DELBET, P. *Des suppurations pelviennes chez la femme*. Paris, 1891.—15. DORAN, A. "The Treatment of Chronic Disease of the Uterine Appendages," *Trans. Med. Soc. Lond.* vol. xiv. London, 1891, pp. 239-251.—16. *Ibid.* "The Relations to each other of Inflammation of the Endometrium, Fallopian Tube, Ovary, and Pelvic Peritoneum," *Trans. Obst. Soc. Lond.* vol. xxxii. for 1885, p. 164.—17. DUNCAN, J. MATTHEWS. *A Practical Treatise on Perimetritis and Parametritis*. Edin. 1869.—18. *Ibid.* "On Hæmorrhagic Parametritis," *Trans. Obst. Soc. Lond.* vol. xxix. for 1887, pp. 191-197.—19. DUNCAN, W. "On Chronic Diseases of the Uterine Appendages," *Trans. Med. Soc. Lond.* vol. xiv. London, 1891, pp. 214-239.—20. GRIFFITH, W. S. A. "Perimetric Abscess," *Trans. Obst. Soc. Lond.* vol. xxiv. for 1882, p. 299; "Retro-uterine Perimetric Abscess," *Ibid.* vol. xxv. for 1883, p. 18; "Serous Perimetritis," *Ibid.* vol. xxvii. for 1885, p. 168; "Anterior Perimetritis and Anterior Parametritis," *Ibid.* vol. xxix. for 1887, p. 147; "Parametritis dextra," *Ibid.* vol. xxx. for 1889, p. 5.—21. *Ibid.* "Perimetritis and Parametritis," *St. Barthol. Hosp. Reports*, vol. xvi. for 1880, pp. 285-305.—22. *Ibid.* "A Fatal Case of Perimetritis," *Ibid.* vol. xviii. for 1882, pp. 291-296.—23. HERMAN, G. E. "Lectures on Parametritis," *Clinical Journal*, vol. vi. Nos. 9, 10, 11, 12. London, 1895.—24. JONES, MARY A. DIXON. "Removal of the Uterine Appendages," *Med. Record*. New York, Aug. 21, 1886.—25. KEILLER, W. "Pelvic Peritonitis and Cellulitis," *Amer. Journ. of Obst.* vol. xxviii. No. 3. New York, 1893.—26. LEWERS, A. H. N. "Double Pysosalpinx with Rupture of the Tubes," *Trans. Obst. Soc. Lond.* vol. xxvii. for 1885, p. 298.—27. *Ibid.* "Note on the Post-mortem Appearances of a Phlegmon of the Broad Ligament," *Ibid.* vol. xxx. p. 7.—28. MACCLINTOCK, A. H. *Clinical Memoirs on Diseases of Women*. Dublin, 1863.—29. MACDONALD, A. "Latent Gonorrhœa in the Female Sex, with special Relation to the Puerperal State," *Obst. Journ. Gt. Brit.* vol. i. 1873, p. 254 (Abstract).—30. MARTIN, A. "Ueber Tubenerkrankung," *Zeitschr. für Geburtshülfe und Gynäkologie*, Bd. xiii. Stuttg. 1886, pp. 298-311.—31. *Ibid.* "Colpotoxia anterior," *Monatsschrift für Geburtshülfe und Gynäkologie*. Berl. Aug. 1895.—32. *Ibid.* *Die Krankheiten der Eileiter*, Leipz. 1895.—33. MAURY, R. B. "How shall we treat our Cases of Pelvic Inflammation?" *Amer. Journ. of Obst.* vol. xxiv. No. 1. New York, 1891.—34. *Ibid.* "The Present State of our Knowledge of Pelvic Inflammation, with Special Reference to the Treatment of Pelvic Abscess," *Amer. Journ. of Obst.* vol. xxviii. No. 6. New York, 1893.—35. MENGE, K. "Ueber die gonorrhöische Erkrankung der Tuben und des Bauchfells," *Zeitschr. für Geburtshülfe und Gynäkologie*. Band xxi. Stuttg. 1891, pp. 119-159.—36. MONPROFIT. *Étude chirurgicale sur les inflammations des organes génitaux internes de la femme: salpingites et oovites*. Paris, 1888.—37. NOEGGERATH, E. *Die latente Gonorrhoe im weiblichen Geschlecht*. Bonn, 1872.—38. *Ibid.* "Ueber latente und chronische Gonorrhoe beim weiblichen Geschlecht," *Deutsche medicin. Wochenschrift*, 1877, No. 49. Berlin.—39. POLK, W. M. "A Study of Peri-uterine Inflammation in its Relation to Salpingitis," *Trans. Assoc. Amer. Physicians*, vol. i. Philad. 1886, pp. 145-169.—40. *Ibid.* "Inflammations of the Uterine Appendages and Peritoneum," *Clinical Gynecology by American Authors*. Edit. by Keating and Coe, vol. i. Edin. 1895, pp. 335-382.—41. Pozzi, S. *Traité de gynécologie*, 2me édit.—42. ROSTHORN, A. V. "Vierzig Fälle von Abtragung und Entfernung der Anhänge der Gebärmutter," *Archiv für Gynäkologie*, Bd. xxxvii. Berl. 1890, pp. 337-419.—43. SÄNGER, MAX. "Ueber die Beziehungen der gonorrhöischen Infektion zu puerperal-Erkrankungen," *Verh. der deutsch. Gesellschaft für Gynäkologie*. Leipz. 1886.—44. *Ibid.* *Die Tripperansteckung beim weiblichen Geschlechte*. Leipz. 1889.—45. SEGOND, P. *De l'hystérectomie vaginale dans le traitement des suppurations pelviennes*. Paris, 1891.—46. SINCLAIR, W. JAPP. *On Gonorrhœal Infection in Women*. London, 1888.—47. SCHMITT, A. "Zur Kenntniss der Tubengonorrhöe," *Archiv für Gynäk.* Band xxxv. Berlin, 1889, pp. 162-186.—48. TAIT, LAWSON. "On the Treatment of Pelvic Suppuration by Abdominal Section and Drainage," *Med. Chir. Trans.* vol. lxiii. for 1880, pp. 307-316.—49. *Ibid.* "Recent Advances in Abdominal Surgery," *Trans. Int. Med. Cong.* 1881, vol. ii. p. 228. London.—50. *Ibid.* *Diseases of Women and Abdominal Surgery*, vol. i. Leicester, 1889, pp. 333-435.—51. *Ibid.* "A Discussion of the General Principles involved in the Operation of Removal of the Uterine Appendages," *New York Med. Journ.* Nov. 20. 1886.—52. TARGETT, J. H. "Acute Suppuration and Sloughing of Ovaries after Parturition," *Trans. Obst. Soc. Lond.* vol. xxxvii. for 1895, p. 216.—53. TAYLOR, J. W. "Clinical



Lecture on Pyosalpinx, with Remarks on the old faith and the new regarding Parametritis and Perimetritis," *Lancet*, 1889, vol. ii. p. 581.—54. TERILLON, O. *Salpingites et ovarites*. Paris, 1891.—55. TREVES, F. *Peritonitis*. London, 1894.—56. VIRCHOW, R. "Ueber puerperale diffuse Metritis und Parametritis," *Archiv für path. Anat. und Physiol.* herausg. v. R. Virchow, Bd. xxiii. Berl. 1862, pp. 415—427.—57. WEST, C. *Lectures on Diseases of Women*, 4th edit. by J. Matthews Duncan. Lond. 1879, pp. 421—452.—58. WHITE, J. W. "Oöphorectomy in Gonorrhœal Salpingitis," *Brit. Med. Journ.* Feb. 19, 1889.—59. WILLIAMS, Sir J. "On Serous Perimetritis," *Trans. Obst. Soc. Lond.* vol. xxvii. for 1885, pp. 169—181.—60. ZWEIFEL, P. "Ueber Salpingo-Oöphorektomie," *Archiv für Gynäk.* Band xxxix. Hft. 3, Berl. 1891, pp. 353—392.

C. J. C.

---

## PELVIC HÆMATOCELE

**Definition and Synonyms.**—An encysted tumour formed by the extravasation of blood from some part of the generative organs into the pelvic tissues in the immediate neighbourhood of the uterus.

Much discussion has taken place concerning the true definition of pelvic hæmatocele and the pathology of it. Thus it has received the various appellations — "retro-uterine hæmatocele," "peri-meterine or peri-uterine hæmatocele," "hæmatoma," "pelvic thrombus," and the like. The term "pelvic hæmatocele" is the most comprehensive, as it may be employed to include all forms of tumours in the true pelvis formed by extravasated blood, irrespective of their exact relation to the uterus, and of the theories of pathologists; premising always, of course, that they have their origin in the reproductive organs.

**General Pathology.**—*Introductory.*—It is comparatively within recent years that attention has been called to the subject of pelvic hæmatocele, and that it has found a place in medical nomenclature.

Some short account of the earlier recorded cases, and of the successive steps taken to investigate their nature, is essential to the elucidation of its pathology. The earliest instances in which the recorded facts leave no doubt as to the identity of the disease occurred in the practice of Récamier in the Hotel-Dieu in Paris. One of these was published in the *Lancette Française*, July 21st, 1831, under the title "Tumeur sanguine du Bassin." A woman, 28 years of age, after a miscarriage, had a large tumour in the true pelvis behind the uterus, which projected into the vagina. Récamier, believing it to be an abscess, opened it; but, instead of pus, dark, half-coagulated blood escaped from the aperture. In 1841 M. Bourdon, in the *Revue médicale*, described the physical signs of blood tumours situated in the peri-uterine cellular tissue of the pelvis; and somewhat later Velpeau in his *Mémoire sur les cavités closes* published additional cases, and was evidently acquainted with the true character of these affections. Other cases were reported later by



Bernutz and Piogy. Bernutz claimed priority in having pointed out in 1848 the relation between pelvic blood tumours and disturbance of the menstrual function; but in his opinion the honour of having first discovered true hæmatocele belongs to Ruysch in 1691.

Be this as it may, the first clear and intelligible account of the affection was published in France by Nélaton, the distinguished Professor of Clinical Surgery in Paris; and to him belongs the merit of bringing the affection into prominence and giving it a permanent place in our nosology. It was in 1850 that Nélaton drew the attention of his class to the occasional occurrence of fluctuating tumours situated between the uterus and rectum, which on being laid open were found to contain extravasated blood. From the position of the tumour he gave it the name of "retro-uterine hæmatocele"; a title still applied to it by some authors, but too limited in its definition: further investigation has demonstrated that, besides the posterior aspect of the uterus, hæmatocele is found in other localities in the pelvis.

In 1851 M. Nélaton made retro-uterine hæmatocele the subject of Clinical Lectures, and these were subsequently published in the *Gazette des hôpitaux*. The description there given is clear and precise; and without detracting from the merits of those who preceded him, it may be said that until the appearance of Nélaton's Clinical Lectures the subject was absolutely unknown to the majority of medical practitioners in France and elsewhere. Even in 1850 the celebrated surgeon Malgaigne attempted to enucleate a supposed fibroid tumour of the uterus, which proved to be an encysted collection of blood; the operation was followed by fatal hæmorrhage.

The lectures of Nélaton having drawn attention to the subject, it was soon discovered that the disease in question was by no means so rare as might be supposed from the little which had been written upon it. Many contributions speedily followed. Among the first and best of the theses on hæmatocele was that of Viguès, a pupil of Nélaton; and later followed those of Fénerly, Voisin, and others. In 1860 Voisin published an octavo volume on *Retro-uterine Hæmatocele and Non-encysted Extravasations of Blood in the peritoneal Cavity of the Pelvis*; and further contributions were made in France by Laugier, Rouget, Fénerley, Puech, and Bernutz and Goupil; in Germany by Virchow, Seanzoni, Braun, Herber, Crédé, Breslau, Seyfert, and Olshausen. In Great Britain the subject received early notice in Dr. Tilt's *Diseases of Women*, and in lectures published by Dr. West and Sir James Simpson. Dr. Barnes especially drew attention to the frequency of the accident. A numerous array of instances were chronicled, and many observers wrote about it or made it the subject of discussion in debating societies. Among others may be mentioned Drs. M'Clintock, Matthews Duncan, Tuckwell, Meadows, and Madge.

Hæmorrhage into the pelvic cavity may take place in various positions; and it may issue into the peritoneal cavity, or outside and beneath the peritoneum into the pelvic cellular tissue. Hæmorrhage,

again, in the pelvis varies in amount and in diffusion. It may be so extensive as to give neither time nor opportunity for it to become encysted — the patient may die speedily from shock and loss of blood: in other cases it may be so small as to afford very indefinite indications of its presence. Further, blood extravasation into the pelvis may arise from a diversity of causes even in connection with the generative organs.

Hence much controversy has taken place concerning the true definition of hæmatocele. Under the name “retro-uterine hæmatocele” Nélaton and his followers grouped together all the varieties of blood tumour found posterior to the uterus or around it, irrespective of their causes. Voisin restricts the name to those cases in which the blood is extravasated into the peritoneal sac between the uterus and rectum; and further, according to him, the result must be due to some accident of menstruation. Bernutz, one of the earliest and most authoritative writers on the subject, insists that Nélaton’s grouping is irrational, and that pelvic hæmorrhage is not a specific disease apart from that which caused it, but is simply a hæmorrhage symptomatic of certain morbid conditions which ought to be the main object of pathological study. In his endeavour to define cases of true hæmatocele, Bernutz adduces the analogy between the tunica vaginalis in the male and the recto-uterine *cul-de-sac* in the female, — the only difference between the two being that the folds of peritoneum forming the tunica vaginalis are external to and shut off from the abdominal cavity in surrounding the testicle; while in the female the analogous folds of peritoneum, subtending the two ovaries, together form an open sac communicating with the general peritoneal cavity. As, therefore, he would apply the name “hæmatocele” in the male to a collection of blood in the tunica vaginalis, he restricts it in the female to collections of blood in the retro-uterine pouch of the peritoneum; and, in respect of their causes, to those blood tumours which arise from some accident of menstruation. It is obvious that this definition could not be accepted by many recent authors, who believe that ectopic gestation is the most frequent cause of hæmatocele in all its forms. By authors generally, both in Great Britain and elsewhere, the term “hæmatocele” in women is used in a wider and more comprehensive sense; and includes tumours formed by the extravasation of blood not only into the retro-uterine *cul-de-sac* of the peritoneum — although clinically this may be the most common — but also elsewhere around the uterus; and more especially into the cellular tissue of the pelvis which lies outside the peritoneum. Even in France, the country to which we owe the largest amount of original work on this disease, the term “hæmatocele” is now used in this more comprehensive sense; and Pozzi, one of the latest and best French writers on Gynæcology, adopts this description.

Derangement of the menstrual function is recognised as a common and fertile source of pelvic hæmorrhage, but other causes are not excluded. The late Dr. McClintock, in an able paper on this subject, remarks that he “cannot agree with Bernutz that to discover the existence of pelvic hæmatocele constitutes only the half and the less important half of the

diagnosis; on the contrary, it is, I should say, by far the most important half; for if we overlooked the hæmatocele, and were cognisant only of the morbid condition from which it had arisen, what errors of prognosis and treatment might we not commit?" As a practical fact, it may be pointed out that the treatment of effusions of blood into the pelvis must be influenced in a much greater degree by the rapidity, extent, and position of the extravasation, than by the pathological condition which caused them; and although Bernutz is doubtless correct in his assertion that the sanguineous effusion is only a symptom and effect of some pre-existing pathological condition — in the same sense as menorrhagia may be — yet all Bernutz contends for would be attained by bearing in mind that, like metrorrhagia or uterine hæmorrhage, it may proceed from a diversity of pathological causes.

Concerning the anatomical situation of pelvic hæmatocele, again, much controversy has arisen. Voisin and Bernutz only admit those cases to be true hæmatocele in which the blood is poured into the peritoneal sac between the uterus and rectum. The instances in which blood is extravasated into the cellular tissue, around the uterus, and beneath and outside the peritoneum, they regard as cases of "thrombus," akin to those blood tumours which are found occasionally in the external genitals in connection with the puerperal state, or produced by violence and disturbances other than those associated with menstruation. Accumulated observations leave no doubt that, in the largest number of cases of encysted hæmatocele, the blood is situated within the peritoneal sac: but there is abundant evidence to show that this is not invariably so, and that the same influences are at work in both forms. Further, Mr. Lawson Tait and others have shown that an extravasation of blood into the pelvic cellular tissue may eventually burst its restricted boundaries and be poured into the peritoneal cavity. It seems, therefore, unwarrantable to separate the two forms of pelvic blood swelling, and to give them separate appellations. Both have their position deeply situated in the pelvis; both arise from the rupture of, or escape of blood from vessels supplying the organs in the pelvis; and in both, if the extravasation be sufficiently sparing and slow, the blood becomes encysted. Moreover the symptoms and physical signs are often so much alike as to be indistinguishable. The family resemblance in the menstrual group is further borne out by the tendency of the tumour in both kinds to appear about the time of a catamenial period. If it be urged that the ovaries, the Fallopian tubes, and the uterus are the organs principally engaged in the menstrual act, and that any escape of blood from these internally is most likely to flow into the cavity of the peritoneum, it may be pointed out that during menstruation, and especially at its commencement, the whole generative system becomes more vascular: the circulation in the broad ligaments is increased; the hæmorrhoidal vessels become distended; all the pelvic organs, indeed, receive an increased supply of blood, and the abdomen itself becomes fuller. Rouget and others have described an intricate and tortuous plexus of vessels



lying just beneath the ovary in the folds of the broad ligaments, which during menstruation and other analogous conditions becomes so distended as to form a sort of erectile organ. This is termed the bulb of the ovary. Anatomical conditions favourable to the escape of blood in certain perturbed states exist, therefore, in all the pelvic tissues; but more especially when the catamenia occur. Looking at these anatomical conditions, it may be more obvious how hæmorrhage takes place into the retro-uterine *cul-de-sac* of peritoneum; yet there is ample evidence that blood is occasionally extravasated into the cellular tissue in such quantities as to form a considerable tumour. Evidence from the post-mortem room is not sufficient to furnish data as to the relative frequency of the two forms, for the reasons that in the fatal cases the extravasation is more frequently intraperitoneal, and that death rarely takes place from the extraperitoneal form. Nevertheless there is other evidence forthcoming to prove the occurrence of the last-named form. Bernutz himself admits its existence, but declines to include it in the form "hæmatocele." The opinion that hæmatocele may be extra- as well as intraperitoneal was shared by MM. Hugier, Nonat, Robert, Becqueril, Verneuil, and Prost. Nonat, after a careful study of this affection in La Pitié and elsewhere, states in his work on *Diseases of the Uterus* that he believes the extraperitoneal form to be more frequent, though less grave than the other; and he believes it possible to diagnose the two varieties and prescribe appropriate treatment for each. The late Sir James Simpson published an account of a post-mortem examination where the blood was undoubtedly beneath the peritoneum behind the uterus, and by a diagram shows the manner in which the serous membrane was raised up so as to form the roof of the cyst. In another of Sir James Simpson's cases, one of the hæmorrhoidal vessels had given way, and produced a blood tumour in the cellular tissue in front of the rectum. Dr. Matthews Duncan convinced himself that the extraperitoneal is probably a common form of the disease, though he admits that the extravasation is intraperitoneal in many cases. Tuckwell collected forty-one cases where post-mortem examination was made: of these the extravasation of blood was intraperitoneal in thirty-eight; this only proves that the intraperitoneal form is more fatal, which we know. Byrne and Beigel believe that the extraperitoneal variety is much more frequent than is supposed, and the former states that it often gives rise to pelvic abscess or cellulitis. It may be that some forms of extraperitoneal hæmatocele, like thrombus of the external parts, are especially associated with pregnancy; as the pelvic vessels are then much more distended than at other times. If in these circumstances rupture of a vein take place into the cellular tissue of the broad ligament, it no doubt bears an analogy to thrombus of the vulva in the puerperal state; but it is deeply situated in the pelvis, it is dependent on the same causes, attended by the same symptoms, and requires much the same treatment as the intraperitoneal form. The existence of extraperitoneal hæmatocele is now definitely admitted by authors at home and abroad, and there seems no valid reason why



the definition of hæmatocele should not include this form as well as the other. As I have said, the majority of treatises on Diseases of Women adopt this definition, and it is convenient as well as practically useful.

In cases of hæmatocele, therefore, the extravasated blood may have two separate localities: — I. It may be within the peritoneal cavity. II. It may be situated beneath and outside the cavity of the peritoneum in the cellular tissue of the pelvis. This is called “hæmatoma” by some authors, and should be clearly understood to be less grave than the former.

I. Concerning the intraperitoneal form of hæmatocele, it is necessary to note that there are two varieties of hæmorrhage which differ, not in the causes or sources of the bleeding, but in its abundance and rapidity from whatever source it comes. Thus, if hæmorrhage be abundant and rapid no defined tumour is formed, but the blood spreads itself over a large surface of the peritoneum, and the patient either speedily sinks from collapse or dies from the extensive peritonitis. There is no time or opportunity for the blood to become encysted, and hence this variety has been called “non-encysted hæmatocele or extravasation.” If, on the other hand, blood be poured out in small quantity and sufficiently slowly, it commonly gravitates into the retro-uterine *cul-de-sac*, and there being surrounded by lymph barriers and adhesions which have been thrown out by inflammatory processes of a protective character, it becomes encysted. The way in which blood becomes encysted to form hæmatocele in the retro-uterine pouch, as first described by Voisin, is as graphic as it is true. He says —

When blood escapes from the ovaries, the tubes, or the uterus, it falls naturally behind the broad ligaments into the retro-uterine peritoneal space, limited before by the broad ligaments and uterus, behind by the rectum and lateral folds of the peritoneum, on all sides by serous membrane. Above the *cul-de-sac* is open and communicates largely with the rest of the abdominal cavity. In some rare cases the blood is carried in part into the vesico-uterine space, but in a very small proportion compared with the mass extravasated behind the uterus. Hardly have some drops of blood penetrated into the serous cavity than it inflames. This inflammation results in speedily establishing adhesions between all the pelvic organs, or rather between their peritoneal coverings. The coils of intestine are pushed upwards by the extravasated fluid, or rise upwards by their own lightness. The collection of blood encysts rapidly, thanks to the energy of the inflammation of the serous membrane and the formation of cellular adhesions. The sides of the tumour, then, are limited — before, by the broad ligaments; behind, by the rectum and peritoneum; below, by the retro-uterine *cul-de-sac*; above, by the coils of intestine which, by their adhesions to the fundus uteri, the broad ligaments, the ovaries, the tubes, the round ligaments, and the peritoneum which covers the lateral parts of the pelvis, form for the cyst a sort of resisting roof.

As will be seen on a subsequent page, some authors hold that adhesions, the result of pre-existing peritonitis, are generally present before

blood extravasation takes place, and thus help to form the cyst wall of a retro-uterine hæmatocele.

**II. In the extraperitoneal form** the blood is poured out into the meshes of the cellular tissue which surrounds the uterus and other pelvic organs. It is said to be more frequent in women who have borne numerous children, and in whom the pelvic tissues are weakened and the areolar tissue relaxed. The tumour is much less frequently situated between the uterus and rectum. It may, indeed, be formed in any part of the pelvis where vessels ramify through the cellular tissue, and where the areolar tissue is lax enough to permit separation of its layers. The most frequent site is, laterally, between the folds of the broad ligaments. Here the vessels are most numerous, have the largest calibre, and, being surrounded by looser tissue than elsewhere, are less well supported. The next most frequent site is behind the uterus; but inasmuch as the peritoneum is firmly attached to the posterior surface of that organ, with very little intervening areolar tissue, the tumour tends to run round and embrace the rectum, infiltrating the cellular sheath which gives it its mobility. Not infrequently both the lateral and posterior aspects of the uterus are invaded, the cellular tissue in both localities being more or less continuous. If the extravasated blood be considerable and the tumour large, the peritoneum will be separated from the structures upon which it normally lies, and either pushed aside, or raised upwards towards the cavity of the abdomen, as in the cases figured by Sir James Simpson and others: or the folds of the broad ligaments may be separated, and their upper borders elevated. The position, shape, and dimensions of the swelling vary with the situation of the vascular rupture and the amount of blood effused.

The blood swellings in the pelvic cellular tissue — or hæmatomas — as a rule are not so large as those found in the cavity of the peritoneum. There is more resistance to the escape of blood, or a sort of natural hæmostasis, due to the density of the tissues permeated; and, although a certain quantity of lax cellular tissue surrounds the various pelvic organs, it is divided by layers of pelvic fascia and the attachments of the peritoneum. Occasionally, however, the pressure exerted is such that the peritoneal layer is raised quite above the pelvis; or the layer gives way, and secondary rupture takes place into the peritoneal cavity. There is reason to believe that small extravasations of blood take place much more frequently than was at one time supposed, both into and outside the peritoneum about the time of the catamenial periods. If the quantity of blood be sparing there may be no very well-defined swelling, and the symptoms being obscure the diagnosis is difficult. The results of physiological experiments, as well as observation in cases of laparotomy, prove that small quantities of blood effused into the cavity of the peritoneum speedily disappear when the serous membrane is healthy. The case is quite otherwise when the peritoneum has been altered by inflammation, for its power of absorption is then impaired or destroyed. After the occurrence of obscure symptoms of blood effusion,

repeated, it may be, more than once, the formation of a distinct tumour may indicate that it is but the further development of mischief which may have been suspected but not verified. The evidence of the post-mortem room also points to the fact that hæmorrhages both intra- and extraperitoneal may be progressive.

**Sources of Hæmorrhage.**—The sources which have been described are somewhat numerous; and more extended observation has multiplied them. Voisin described only three causes; namely, congestion and hæmorrhage from the vesicles of de Graaf during a menstrual period; reflux of blood from the uterus into the tubes and from thence into the peritoneum, and hæmorrhage originating in the Fallopian tube itself. Bernutz speaks of five sources, and classes the varieties in accordance with the cause, thus—i. Hæmatocele symptomatic of rupture of utero-tubal varices; ii. Hæmatocele symptomatic of bloody exhalation from the pelvic peritoneum; iii. Hæmatocele symptomatic of rupture of the ovary or Fallopian tube; iv. Hæmatocele symptomatic of difficult menstrual excretion; v. Hæmatocele symptomatic of excessive secretion from the genital organs—menorrhagic hæmatocele.

More recent researches have tended to the better definition of the sources of hæmorrhage, while at the same time a larger number of sources is recognised. The evidence concerning some of the former supposed sources of hæmorrhage is now regarded as indistinct and inconclusive, while the frequency of others is sustained by accumulated observation and testimony.

i. The most frequent source of large extravasations of blood into the pelvis is undoubtedly the various forms of *extra-uterine gestation*, be they tubal, ovarian, or other variety. Viguès and Gallard believed the rupture of a tubal pregnancy to be the cause of all cases of intra-peritoneal hæmatocele. Mr. Lawson Tait regards ectopic gestation as almost the exclusive cause, and likely to be always fatal unless operated upon. It is to be noted, however, that he draws a broad distinction, in respect of danger, between effusions of blood into and outside the peritoneum, whether due to extra-uterine gestation or not; but he has no doubt that a collection of blood from this cause, originally in the cellular tissue, may break its bounds and burst into the peritoneum in a secondary manner. Fritsch, in his *Krankheiten der Frauen*, makes hæmatocele and the bursting of an extra-uterine pregnancy synonymous. In a recent *System of Gynecology*, edited by Baldy, it is stated, in accordance with the teaching of Lawson Tait, that in nearly all cases ectopic gestation is the cause of pelvic hæmatocele of whatever kind. It is admitted that there may be exceptions, but they are rare. This statement goes too far. It does not accord with my own experience, and to accept it would be to ignore the recorded observations and opinions of some of the best authorities on the subject. Even when a tubal pregnancy has been present, it may have been but the indirect cause of hæmatocele: for the blood extravasation has occasionally come, not from rupture of the ectopic sac, but from a dilated vein in the broad ligament. Effusions of blood aris-



ing from the rupture of an extra-uterine pregnancy would, of course, be altogether excluded from the definition of hæmatocele by authors like Bernutz and Voisin, who restrict the term to cases occurring as the result of some accident in menstruation. The symptoms are so exactly parallel to blood extravasations arising from other causes, and sometimes so absolutely indistinguishable from them, that clinically it is impossible to separate them. The hæmatocele may be clearly discernible, but the cause wrapped in obscurity. The blood effused in the several forms of ectopic gestation is sometimes so large and sudden as to merit the appellation given by Bernutz as "dramatic," or by Dr. Robert Barnes as "cataclysmic"; and such cases correspond to those described by Voisin as "non-encysted hæmatocele or extravasation." Occasionally this rupture of an extra-uterine pregnancy takes place in successive stages, and by repeated attacks following exactly the course of such extravasations of blood from other causes; if so the cases are most obscure, both as to diagnosis and causation. Mr. Bland Sutton, in explaining the way in which sudden and large extravasations take place in these instances contends that in some at least of the tubular fœtations an apoplexy occurs in the membranes surrounding the embryo. Thus an ovum the size of a walnut is suddenly enlarged to the bulk of an orange, and the tube being unequal to the distension, gives way and rupture occurs, either into the peritoneum or into the broad ligament. Mr. Knowsley Thornton has reported an instance where the rupture of an extra-uterine sac, not larger than a hazel nut, gave rise to fatal hæmorrhage.

ii. Apart from pregnancy, the rupture of a vessel in some of the structures of the ovary is a not infrequent cause of pelvic hæmatocele. This does not mean hæmorrhage in connection with large ovarian tumours, when bleeding commonly takes place into the interior of cysts rather than outside the mass: ovarian cysts are occasionally filled with coagulated blood, which has been poured into their interior from the rupture of a vessel in the walls of the cyst; and death has been known to result from intracystic hæmorrhage of this kind. Nor should it include the escape of blood from the stump of an ovarian cyst treated intraperitoneally, noticed by Sir Spencer Wells; this is, but an accident of the ovarian operation. In normal conditions it has been fully proved that at or about periods which correspond in the woman with the appearance of the catamenia, one or more Graafian vesicles, near the surface of the ovary, mature, become distended with blood, and at last rupture to discharge their contents into the infundibulum of the Fallopian tube. Ordinarily this physiological process is so perfectly performed that no blood escapes into the peritoneum from the encircling fimbriæ, and little disturbance is produced. When, however, any antecedent morbid change has so altered the structure of the ovary as to induce undue hyperæmia, or to increase the size of its blood-vessels, or again to produce such adhesions of the fimbria as to interfere with the complete grasping of the ovary during the act of ovulation, then blood may be effused in more considerable quantity. Congestion, chronic



inflammation, and hypertrophy of the ovary, by enlarging the calibre of the blood-vessels, induce a tendency to unusual hæmorrhage at the period of ovulation; and the same may be said of other morbid conditions of the ovary. Voisin arrives at the conclusion that there is usually some pre-existing disease of the ovary which disposes to laceration of the blood-vessels and consequent extravasation; and he adduces several examples of hæmatocele produced in this way. It is by no means uncommon in the post-mortem room to find small collections of blood in the substance of the ovary, especially when it is beginning to undergo degeneration, cystic or otherwise. Small cysts filled with coagulated blood are often found, and at times the distension has been so great as to produce rupture and extravasation into the peritoneal cavity. This catastrophe is the more likely to occur if the effects of accident or violence be superadded to the existing morbid condition. M. Gallard suggests that, in some cases, hæmatocele is due to the presence of an ovule, impregnated or not, which has missed the oviducts, and with its surrounding blood has dropped into the peritoneum.

iii. The Fallopian tube, the mucous membrane of which contributes to the menstrual flux, would seem occasionally, when unusual excitement or congestion exists, to be capable of pouring out so large a quantity of blood as to produce hæmatocele. This cause of hæmatocele was first indicated by Fénerly. It is believed, also, that if blood has been retained in the uterine cavity by occlusion of the os, or by displacement — such as extreme retroflexion of the womb — it may be driven by uterine contraction along the oviducts into the peritoneal cavity; or burst the tube and so form hæmatocele. Dr. Emmet thinks the regurgitative theory elaborated by Bernutz worth a passing notice only, and Dr. Meadows did not think the accident possible in the ordinary state of the tubes; to make it possible they must be abnormally dilated, and the contents thus forced towards the fimbriæ. Matthews Duncan, however, held that blood might be driven along the Fallopian tubes and into the peritoneal cavity when there was no obstruction or occlusion at the os uteri, or abnormal dilatation of the tubes. He pointed out that dilatation of the tubes occurs periodically to permit the passage of ova, as well as when pathological conditions have led to a more permanent state of dilatation and patency. Under these circumstances, even when the os uteri is sufficiently pervious, the mechanical arrangements of the viscera and the aerostatic mechanism of the abdominal walls will drive fluid along the tubes, and so favour the production of hæmatocele. Trousseau held the opinion that a blood exhalation from the mucous membrane of the tube near the fimbriated extremity might account for cases of hæmatocele where the source was the tube; and Barnes adds a group of problematical cases where hæmatocele was attributed to blood driven along the tubes during abortion, on account of some hindrance to its flow by the natural passages.

Operations during life, as well as post-mortem observation, afford strong evidence that hæmatocele may be produced by the escape of blood from the tubes under certain conditions altogether apart from

tubal pregnancy. Imlach, in several cases of laparotomy for hæmatocele, found both tubes distended with thick black blood similar to that present in the abdomen. Dr. Barlow has reported a case where the tube was distended with clot protruding from the outer extremity—the inner being occluded; and Scanzoni has described a case in which a tube was distended to the size of a finger and held two ounces of blood; sixteen ounces had escaped into the peritoneal cavity: there was no pregnancy. Dr. Cullingworth has reported a case where rupture of a varicose vein inside the Fallopian tube produced hæmatocele. The hæmorrhage, taking place from the abdominal end of a Fallopian tube, is regarded as likely in most instances to be progressive in its character, rather than sudden and abundant; and in this way to alter the neighbouring peritoneum by the intercurrent inflammation it produces. Thus it is inferred that minor forms of hæmatocele may arise, accompanied with only obscure pelvic discomfort, and giving little evidence of tumour until accumulation has occurred as the result of attacks frequently repeated; then the altered peritoneum, in its turn, may add accretions to the mass, by exhaling blood from its altered surface, as in primary hæmorrhagic pachy-peritonitis. These are probably some of the cases in which adhesions are said to be present before the formation of distinct hæmatocele, as indicated by Schroeder and by Hart and Barbour, and in which an antecedent roof is partly formed over Douglas' pouch.

Guérin advances the view that blood may regurgitate through the tubes, as the result of membranous dysmenorrhœa, and be effused into the peritoneal cavity. The mucous membrane of the uterus, he says, swells up so as to fill the whole cavity: this being exfoliated towards the end of the period may absolutely plug the os uteri; and uterine contractions, to expel it, drive blood through the Fallopian tubes into the abdominal cavity. Pozzi thinks this explanation quite natural.

iv. Rupture of vessels in the bulb of the ovary or pampiniform plexus, lying between the folds of the broad ligament, is enumerated among the causes of hæmatocele by Puech, Voisin, Scanzoni, Bandl, and others. In certain patients the veins here, especially in the pampiniform plexus as well as in the lower extremities round the vulva and anus, are apt to become varicose. The varicose condition of the ovarian venous plexus is well delineated by Winckel: he states that this varicose condition is frequently met with in the post-mortem room, although Scanzoni believes it to be a rare one. In the varicose condition, which may be found in pregnant and non-pregnant women, the coats of the veins are thinned and weakened, and are prone to give way under increased pressure from muscular efforts, violence, or indeed from the hyperæmia induced at the catamenial periods. Winckel has also shown that phleboliths in the varicose veins may ulcerate through their walls and so favour hæmorrhage.

As the veins are enclosed in the areolar tissue, it seems likely that in some cases an extraperitoneal hæmatocele would be produced by such rupture; but M. Voisin states that in all cases of this kind which have been recorded, laceration took place into the peritoneal cavity, and the

loss of blood was so rapid and profuse that no time was allowed for it to become encysted, and immediate death was the result.

v. Tardieu and Bernutz, with others, have described instances of intraperitoneal hæmatocele, where the source of bleeding was the altered surface of the peritoneum itself. Virchow explained this as a process similar to that which occurs in "pachymeningitis pseudo-membrosa," in which a like exudation has been noticed. Bandl gives it the name of "pelvi-peritonitis hæmorrhagica." Dolbeau, who gives his adhesion to this theory, asserts that an immense number of cases of retro-uterine hæmatocele are produced by pelvic peritonitis of the hæmorrhagic form, and this explains the less serious nature of some instances as compared with those having a tubal, ovarian, or varicose source; as the bleeding is then more oozing in character.

Hart and Barbour state that it is disputed whether inflammation encysting and limiting the hæmorrhage is antecedent or consequent on it; and think the former view has more evidence in its favour, although some cases support the latter: they give one example, recorded by Lauchlan Aitkin, where the usual physical signs of retro-uterine hæmatocele were observed during life — namely, a retro-uterine tumour bulging into the posterior fornix and displacing the uterus markedly forwards — on post-mortem examination the clotted blood was found without adhesions. Schroeder believed that peritonitis always precedes the occurrence of hæmatocele. Veit says, if the abdominal cavity be healthy no encapsulation of blood occurs; but, if adhesions be present, blood from whatever source clots on them, and fresh adhesions are formed which create a new cyst wall. Schroeder was a capable and sagacious observer, and it seems probable from available evidence that encysted hæmatocele may be formed either with or without pre-existing pelvic adhesions. In the former case, if blood be extravasated below the adhesions, and a restraining roof be thus previously formed for the hæmatocele, the tumour as felt per vaginam will be firm and prominent from the first. When there have been no pre-existing pelvic adhesions, a longer time may elapse before peritonitis lighted up by the extravasations has formed limitations for the blood cyst, and so the hæmatocele may not be recognisable so early. The pre-existence of peritonitis, by impairing the functions of the ovaries and tubes, may indirectly dispose to pelvic hæmorrhage, and the adhesions produced by peritonitis may furnish it; but there are certainly many cases of pelvic hæmatocele, even of the encysted form, in which there has been no previous history of inflammation.

Intraperitoneal hæmorrhage has been known to occur as the result of forcible attempts to replace a distorted or displaced uterus which has been bound down by pelvic adhesions; and by other forms of violent procedure.

vi. Another source of intrapelvic hæmorrhage has been described which differs from the preceding, inasmuch as there is no antecedent peritonitis; but blood oozes from the genital surfaces — internal and



external—and especially from the surface of the peritoneum. To this pathological condition Bernutz gives the name of “metrorrhagic hæmatocele.” It may be associated with the “metrorrhagic diathesis” or with hæmophilia; and it has been particularly noticed during the progress of eruptive fevers; Trousseau therefore called it “cachectic.” Dr. John Phillips has recorded a case in association with rheumatism which he regarded as “cachectic.” The formation of hæmatocele internally is preceded and accompanied by excessive catamenial discharge from the uterus and vagina; and it is presumed that a simultaneous hæmorrhage takes place from the surface of the inner genital canals and of the peritoneum. A diminution of fibrin in the blood has been supposed to favour this exudation.

Bernutz has collected many examples under this head, which he has classed in groups according to certain characteristics or differences. Belonging to this order are not only hæmatoceles characterised by some cachexia, but also those associated with anæmia and chlorosis, in which cases the blood is impoverished and thus more easily escapes from the vessels. Although it is well established, by reasons previously stated, that hæmatocele unassociated with pregnancy takes place most frequently at or about the time of the catamenial period, yet the affection occurs in some instances where the catamenia are absent, and where presumably the function of evolution is suspended. During pregnancy, and after delivery and abortion, extravasation of blood, both into and outside the peritoneum, may give rise to a pelvic blood swelling, having all the characters commonly observed in typical hæmatocele. Examples of this kind have been recorded by West, Voisin, and Bernutz.

**Pathological Anatomy.**—Before describing the morbid appearances in cases of hæmatocele proper, it may be well to indicate what takes place in those instances where, the cause being the same, hæmorrhage takes place so rapidly and in such profuseness that no time is permitted for the blood to become encysted. The reports of post-mortem examinations in such instances are proportionally much more numerous than in those of encysted hæmatocele, inasmuch as the former much more frequently end fatally. No better description is to be found in any author than that originally given by Voisin. He says “in the non-encysted form it is generally found after death that the skin of the body is devoid of colour, and the belly tumid, more particularly in the region of the hypogastrium. Black fluid blood may escape in considerable quantity when the abdomen is laid open. The intestines are distended with gas, and pushed up above the mass of blood contained in the pelvic cavity. The abdominal organs are often covered with clots, the intestines stained of a bluish colour, and in one recorded instance the mesentery was infiltrated with blood. The amount of blood—fluid and coagulated—contained in the pelvis and abdomen has repeatedly been found to be as much as four pounds.” Of twenty cases quoted by Voisin the source of hæmorrhage was traced in sixteen to some distinct lesion: in six, the hæmorrhage came from the ovary; in four, from rupture of an ovarian varix; in two,



from the cavity of the uterus; and in four, from the Fallopian tube. In the remaining four no distinct lesion could be found, and it was supposed that the hæmorrhage arose as an exhalation of blood from the surface of the peritoneum. In these statistics no mention is made of the rupture of a Fallopian tube, or of any other form of extra-uterine gestation, for blood extravasations in association with pregnancy were excluded by Voisin. In instances where such extravasation is dependent on the bursting of a foetal cyst, and if, as is frequently the case, death take place speedily from shock and the quantity of blood effused, some trace of the embryo may be found in the mass of coagulated blood. It is to be noted that ordinarily in these cases rupture takes place early — about the second or third month; although I have seen such a rupture as late as in the fourth month. In the very early cases it may be difficult to find traces of the embryo; but it may be less difficult to find villi of the chorion, either swimming in the effused blood, or attached to the laceration from which the blood has escaped. The presence of either leaves no doubt as to the cause of the catastrophe. It must, nevertheless, be recollected that first there may be a limited hæmorrhage, which will form an encysted hæmatocele; and that this may be followed by a second and more abundant hæmorrhage of the non-encysted variety which carries off the patient. The post-mortem signs in such a case would be much more complex than when only one hæmorrhage had occurred.

As the subjects of encysted hæmatocele commonly recover, the number of autopsies has been comparatively few. In those recorded no great tumefaction of the abdomen was seen. On opening the abdomen the general surface of the peritoneum was found healthy, except that adhesions were occasionally remarked between the intestines. If any of the adhesions forming the boundaries of the cyst had been torn, or otherwise broken down, so as to allow the cyst contents to escape (and these are the cases most likely to terminate fatally), the usual products of inflammation were found — more or less redness and vascularity, lymphic exudations, purulent serum with albuminous flakes. One or both Fallopian tubes have been found distended with blood. Sometimes there have been indications of preceding salpingitis, and lacerations have been detected in the walls of the tubes, in one of the ovaries, or in the vessels of the broad ligament. Imlach states that in fifteen cases of laparotomy for hæmatocele he found both tubes distended with black, thick blood. In none of these instances could there have been a question of tubal pregnancy, or the distension would probably have been limited to one side.

To take a typical example of the morbid appearances in intraperitoneal hæmatocele from Voisin: “On a level with the brim of the pelvis the viscera were seen to be united together, forming the roof of the cyst. The bladder was elevated above the pubes; the uterus close behind it, somewhat increased in size, and rotated upon its axis, in a position different to the usual one. Behind, adhesions united the posterior and superior aspect of the uterus to the rectum, a portion of the sigmoid

flexure of the colon, and several coils of small intestine, the two broad ligaments, and the posterior half of the circumference of the brim of the pelvis. A roof was thus formed over the posterior half of the pelvic excavation. On laying open the cyst the thickness of the walls was found to vary with the amount of fibrinous exudation at the point of incision. The cyst cavity was divided into a number of compartments by cellular bands, but communication existed between the various loculi. All the pelvic organs were more or less fixed, the ovaries displaced, and completely lost among the inflammatory products. In an opening which had been effected previous to the decease of the patient, traces of ulceration were found, and the fistula between the aperture and the cyst was sinuous and irregular."

The contents of the cyst vary with the date at which the blood extravasation took place, and with other circumstances in the history of the case. If time has elapsed after the blood has become encysted, it is usual for the contents of the cavity to consist of clots more or less altered in colour and arrangement, sometimes of a variable quantity of black fluid, grayish at certain points, sometimes like a mixture of soot and water. At times the fluid has a tarry, syrupy consistence; and if suppuration has occurred, there is an admixture of pus. Such products have been observed also when the cyst has been evacuated during life. Under the microscope the contents have been found composed of blood globules completely bereft of colour, and so altered in shape as to be scarcely recognisable; besides these are fat globules, amorphous particles of hæmatoidine, various crystals, and other materials resulting from the transformations of the effused blood. In most cases of encysted hæmatocele the displacement and confusion of parts is so great, in consequence of the effused blood and subsequent inflammation, that the determination of the source of hæmorrhage is most difficult. From various data, however, the blood seems to have come from rupture of a previously diseased ovary in the largest number of instances.

In certain cases post-mortem examination has revealed indications of attempts at spontaneous cure. There have been solidification and changes of colour in the blood-clot, absorption of fluid, and contraction of the sac, which is filled with a growth of connective tissue coloured with blood pigments. These results have been observed when a subsequent attack of hæmorrhage has supervened on a previous one, or when the patient has succumbed to some intercurrent disease.

**Causes.** — Among the *remoter* causes must first be mentioned that of age. Hæmatocele occurs during the period of greatest sexual vigour in women. Dr. Tuckwell found that the decade between twenty and thirty years of age was the period of its most frequent occurrence. According to Schroeder the largest number of cases occur between twenty-five and thirty-five. Out of forty-three cases twenty-seven occurred between those ages. Concerning the frequency relative to other diseases of women there is a wide diversity of opinion. Thus Hugenberger reported only 2 in 3801 cases; and Scanzoni, in twenty-eight years of practice,

had only seen eight cases: Olshausen, on the other hand, places it as high in frequency as 4 per cent of all female diseases, and Dr. Barnes also believes it has a large relative frequency. Bandl holds a position between the two extremes of opinion. Marriage seems to have little influence in its production. Apart from ectopic gestation some deviation from normal conditions in the function of menstruation has been noted by all observers to precede the advent of hæmatocele. Thus it has been generally remarked that the largest number of patients suffer habitually from profuse menstruation — the colour of the discharge being bright and clots frequent. Voisin remarked that the greater number of hæmatoceles occur at the end of the catamenial period, which somewhat militates against his view that the habitually profuse menstrual flow observed in this class of patients is due to a plethoric condition of the system, and against his inference that a recurring over-distension of the blood-vessels in plethoric patients favours the formation of hæmatocele. Bandl, again, regards the frequency of hæmatocele in connection with the monthly periods as due to the high blood pressure in the ovarian arteries at those times which, having been weakened by morbid changes, give way.

Against these theories it may be stated that the high pressure of the arterial circulation is said to be greatest at the beginning of the function, not at the end; and, again, menstrual hæmatocele undoubtedly occurs occasionally in feeble and anæmic patients whose menstruation has been suspended, it may be for months; and who are the subjects of amenorrhœa. In these cases the rupture of an internal blood-vessel does not necessarily take place from any physical obstruction to the catamenial flow by the natural passages, but from constitutional conditions which have impaired the quality of the blood and weakened the integrity of its containing walls. In persons of more robust health, in whom blood extravasation takes place towards the end of the period, the explanation is probably to be found in some fault of ovulation, more particularly in the ovarian cases. There are many reasons and observations which point to the fact that the extrusion of an ovule and the accompanying rupture of an ovisac take place towards the end of the menstrual flow, not at the beginning. Hence the greater liability to attacks of hæmatocele at that time.

The morbid changes in the blood observed during the progress of the exanthemata and other fevers, in purpura and in allied cachectic conditions, frequently lead to attacks of hæmorrhage from the mucous canals; the same conditions have been remarked as predisposing causes of hæmatocele. Further, it has been observed that although in the menstrual history of most women attacked with hæmatocele, the recurrence of the periods may have been regular, the discharge was habitually too profuse and prolonged. Whether abundant or scanty, however, it was nearly always attended with pain, due either to obstruction or to a congested condition of the parts concerned. The cases were few in which the pain was due to obstruction; and in these there was either contraction of the cervix or a displaced fundus. In the rest the dysmenorrhœal suffering was but the expression of a faulty performance of function in the generative



organs, associated with over-distension of its blood-vessels. Among other indirect causes are a weak and varicose condition of the veins in the pelvis, vulva, and lower extremities. Women who have varicose veins of the lower limbs and are liable to hæmorrhoids, to venous swellings in the vulva, and to a weighty, spongy condition of the uterus, habitually menstruate too profusely and painfully, and these are the patients most prone to hæmatocele.

The *immediate* causes enumerated are sudden suppression of the catamenial flow, over-fatigue, violent straining at stool, cold (especially cold foot baths during menstruation), intense mental emotion, premature exertion after abortion, and violence producing injury during menstruation. In a considerable number of cases the immediate cause was traced to coitus, which had taken place either during the catamenial period or shortly after its termination; and the pain began during the sexual act.

**Symptoms and Progress.**— *There are three modes of invasion*, and the symptoms vary for each mode. *In the first and most severe mode*, corresponding to the non-encysted variety of Voisin, *the onset of the symptoms is overwhelming*. The patient is abruptly seized with severe abdominal pain and rigor; these symptoms are succeeded by utter prostration of strength, cold extremities, pallor of countenance, which is anxious and pinched, and subnormal temperature; the pulse is rapid and weak, and the general surface of the body becomes deadly pale. The attack may come on when the patient is apparently in good health; and it has been suggested that the suddenness and intensity of the attack may possibly lead to a suspicion of poisoning. In many cases, certainly, the symptoms bear a very close resemblance to those produced by perforation of the stomach or other abdominal viscus, with extravasation of their contents into the peritoneum; but in addition there is marked anæmia produced by sudden and profuse loss of blood, and the attack is often either coincident with a menstrual period or is preceded by symptoms of pregnancy. The belly becomes tender and hard as well as dull on percussion, but there may be no local tumour observable, as there has been no time for its definition by the formation of adhesions. In these cases Bernutz observes, "we must be upon our guard against too hastily concluding that there is no sanguineous extravasation because there is no perceptible hypogastric or retro-uterine tumour, or because the tumour is slow in developing itself." If there is no abatement in the severe symptoms, hiccough and vomiting occur, the temperature sinks further, and the surface of the skin becomes colder and more blanched. Syncope or complete collapse speedily follows, with a small, almost imperceptible pulse, and death generally ensues within twelve hours. Such sudden and cataclysmal symptoms are commonly observed with the rupture of a tubular or other form of extra-uterine fœtation. Although extremely perilous such cases are not necessarily fatal. Instances have occurred in which the patient has rallied from what was apparently a hopeless condition, and the ovum has died or gone on developing to a later period of



pregnancy, either in its original site, or in some other locality where it had become lodged after being extruded at the time of rupture.

The *second mode of invasion* corresponds with ordinary forms of encysted hæmatocele, extra- or intraperitoneal. Here the symptoms are to some extent the same in character as in the non-encysted form, but those common to both are less in severity. The gravity of the attack varies in accordance with the suddenness and the amount of blood extravasation, and the general condition of the patient. The severity of the attack will be modified by the seat of the effused blood — being more acute and threatening when the blood is poured into the peritoneal cavity, less so when the effusion is into the cellular tissue — for the double reason, that less disturbance is provoked when blood is extravasated beneath the peritoneum than on its free surface; and that effusion is likely to be slower and more gradual into the meshes of the cellular tissue. In both cases the first symptoms indicate pain, exhaustion, and more or less pronounced collapse, due to the escape of blood internally, and they are followed by symptoms of pelvic peritonitis. It has been noticed by several writers that the amount of collapse bears no sort of relation to the amount of blood effused, and is always greater in cases of intraperitoneal hæmatocele because of the sensitive surface. Emmet says he detected by accident, in one instance, an accumulation of blood going on in the peritoneal cavity without the patient suffering any discomfort; and Dr. Playfair has observed an instance where a considerable quantity of blood was found in the peritoneum, though there had been no antecedent symptoms of such a nature as to indicate its presence. Here, probably, the serous membrane had been altered by the previous inflammatory changes surrounding an ovarian tumour; but such cases are rare and exceptional. Commonly the illness is preceded by some notable derangement in the catamenial function, and dates from a menstrual period, which has perhaps been attended with more than usual pain, the discharge being inordinately profuse and prolonged beyond the normal limits. Then immediately after some such effort as straining, coitus, or the like, comes a rigor, with sudden and intense pain in the pelvis often compared to the throes of parturition, and increased by pressure or movement. If the blood effused be considerable in quantity, and particularly if it be thrown into the peritoneum, there is fainting almost amounting to syncope, and this is conjoined with signs of local peritonitis. In several instances it has been noticed that the patient, having been exposed to cold or undue exertion during menstruation or immediately after it, has awoke in the night with a sense of exhaustion and faintness, and has begged to be supplied with food. This preliminary exhaustion has speedily been succeeded by abdominal pain and other characteristic symptoms. The pain may be dull and continuous, or paroxysmal, with recurring exacerbation; and a weight about the anus is often complained of, with frequent ineffectual attempts to evacuate the bowels. There is often tenesmus, and quantities of mucus may be passed — possibly mixed with blood — indicating irritation of the intestinal mu-

cus membrane. Painful micturition is not infrequent, and partial or complete retention of urine may lead to complications in diagnosis and mask the real ailment. The patient prefers to lie upon her back, with the thighs flexed on the abdomen, as usually observed in cases of peritonitis; and there is often considerable distension of the intestines by flatus. Great nervous disturbance is often a prominent feature in these attacks of illness. Coma and insensibility are rarely present, but rather marked distress and restlessness, very inimical to the quietude so necessary for the patient, and severe neuralgic pains, not only in the pelvis but also in the lower limbs and elsewhere. The sort of paralysis of the intestines of some patients is believed by Poncet to be brought about by the joint effect of pressure in the pelvis and the general nervous exhaustion. Supervening on the stage of exhaustion or collapse, acute febrile symptoms speedily develop themselves, with rapid pulse, increase of temperature, and loaded urine. To these symptoms Voisin adds — as a very characteristic sign of the nature of the affection — a rapidly produced and marked pallor of the skin, which assumes a dull whiteness not unlike that which accompanies the cancerous cachexia.

The *third mode of invasion* is that in which the symptoms are developed very gradually and in succession; the case assuming a chronic form. Such instances undoubtedly exist, and are beset with difficulty, as they are apt to be confounded with other affections. As previously remarked, there is no doubt that small extravasations of blood take place in the deeper parts of the pelvis without forming a distinct tumour, or being attended by very definite symptoms. These attacks may be repeated more than once, at uncertain intervals, until one occurs of a character so acute or intense as to leave no doubt of its nature, and connecting itself clearly with the former attacks of less distinctness. In this way there may be many varieties both in reference to the severity of the attack and the time of its recurrence; and the same patient may be the subject of the slighter or graver forms of the malady. These repeated attacks may be associated with the various forms of ectopic gestation, with the “*hæmorrhagic peritonitis*” before named, or with intermitting hæmorrhages from the Fallopian tubes.

Metrorrhagia is one of the commonest concomitant symptoms of pelvic hæmatocœle in all its varieties. So large and continuous in some cases is the loss of blood by the natural passages, that this symptom mainly engrosses the attention of the medical practitioner, to the exclusion of the changes taking place in the deeper parts of the pelvis. Metrorrhagia is, however, not always present.

If the extravasation be large, and yet not too large to be localised, a tumour is soon to be discovered through the abdominal walls, above the pubes, in the direction of the iliac fossa on either side, or projecting downwards in the interior of the pelvis. Dr. West says that he has detected the swelling within forty-eight hours after the first symptoms, and in many cases it may be detected earlier, especially if it be circumscribed by previous pelvic adhesions; although a certain time must

elapse before the blood becomes so consolidated as to be accurately defined. At the first onset of the attack no distinct local tumour may be detected, though the abdomen may be distended by meteorism. When detected it is commonly only somewhat tender to pressure; but occasionally careful examination is rendered impossible for a time by the extreme sensitiveness. The tumour is best examined as the patient lies upon her back; as then external and internal palpation can be combined, and the most accurate estimate formed of the size, consistence, and relations of the mass. Exploration by the vagina and rectum should rarely be omitted, as in this way the position of the swelling between the vagina and bowel is at once ascertained.

In the physical examination of the tumour it is important to recollect that it presents a succession of changes in its density in accordance with its duration. As soon as it can be defined it presents the characters of dulness on percussion, immobility, or very partial mobility, and more or less of irregularity in outline. Soon after its formation it is elastic and indistinctly fluctuating; later it is irregular, and of unequal density—the firmness of its borders closely resembling the results of pelvic cellulitis. If considerable in size, and retro-uterine, it is found on vaginal examination to occupy the posterior half or more of the pelvis, elevating and pushing forward the cervix uteri above the pubes, stretching and pushing down the posterior wall of the vagina, and compressing the rectum behind it into the concavity of the sacrum. In rarer instances, where the tumour is more or less in front of the uterus, the cervix uteri is thrown backwards. Chassaignac has reported a case in which the sanguineous effusion was entirely between the bladder and uterus, thus forcing the entire uterus backwards. In all cases the tumour seems fused into and more or less united to the uterus. Nevertheless the uterus may occasionally be moved in some degree independently, both with the finger and the uterine sound. Where the uterus is pushed upward and forward by a blood mass in the posterior part of the pelvis, it may be traced in outline by external and internal palpation; and the sound verifies its position, proving that the displacement is not due to retroflexion. Matthews Duncan noticed that the length of the uterine cavity was much increased whenever the hæmatocele was large, and that it decreased with its contraction. Frequently the blood tumour has been observed of such dimensions as almost to fill the true pelvis, and to distend and push down the back wall of the vagina so far that it almost reached the vulva. Where the swelling projects very low in the pelvis it has been supposed that it must necessarily be due to extravasation into the cellular tissue, because the peritoneal cavity has a higher level; but when it is recollected that the peritoneum is often prolonged far down the posterior wall of the vagina, and that the lower boundary of the *cul-de-sac* almost reaches the floor of the pelvis, this deduction is seen to be of uncertain value. The tumour sometimes seems much lower in the pelvis than it really is, owing to a large amount of œdema of the recto-vaginal septum below the true level of the hæmatocele. This is



occasionally so considerable as to form a distinct rounded swelling projecting towards the vagina, and it is found also in some cases of cellulitis. The bulging of the tumour downwards is not universal even when blood occupies the retro-uterine *cul-de-sac*, or is in the lowest meshes of the cellular tissue: the retro-uterine pouch may have been unusually shallow, or it may have been partially obliterated by previous pelvic adhesions, as indicated by Schroeder. This author gives illustrations, showing large collections of blood in the pelvis, the lower margin of which is on a level with or a little below the upper part of the symphysis pubis; in one of these diagrams the true pelvis is represented as nearly full of blood. In these cases the finger would have to be carried up to the fornix vaginæ, or even higher, to reach the lower border of the tumour. When the position of the tumour is other than retro-uterine it will displace the pelvic organs in accordance with its dimensions and relative position. On more than one occasion, being formed in front of it, it has been stated to have produced complete retroversion of the uterus. Sir James Simpson, Dr. Graily Hewitt, and others, give illustrations in outline of the extraperitoneal form or *hæmatoma* of some authors. In one of Graily Hewitt's cases the hæmatic tumour rose as high as the crest of the ilium on the right side, and dipped half way down the pelvic canal inferiorly. In the second, the extravasated blood is represented as surrounding the bladder, uterus, and rectum in every direction — as in Hart and Barbour's diagram — and the tumour so formed reached as high as the umbilicus above, and to within a short distance of the perineum below. These, however, are extreme cases, and it must be noted that the illustrations are diagrams, and do not profess to be pathological drawings. More frequently in the extraperitoneal form, or hæmatoma, the swelling will only be felt by internal examination; it will be distinctly lateral in position, occupying one of the broad ligaments, fixing the uterus much in the same way as in pelvic cellulitis, and, in many cases, if seen in the later stages, quite indistinguishable from it. Occasionally the quantity of blood effused is so small that, notwithstanding the presence of characteristic general symptoms, no well-defined tumour can be detected. Drs. West and Matthews Duncan, who had noticed the absence of distinct tumour in some of these cases, inferred that the extravasation was too extensive to become circumscribed; but there are certainly instances where the general symptoms are very marked and characteristic, and yet the amount of effusion has been so slight as to produce but little local tumefaction.

In some rare cases more than one hæmatic tumour has been observed at the same time; one situated in the iliac region, for example — felt by external examination — the other lying deeply in the pelvis, and reached only by vaginal exploration. It is, of course, possible that these apparently separate tumours may have been poles of one long mass.

Some authors have enumerated among the symptoms, during the progress of hæmatocele, an undue pulsation of the arteries in the vagina



and cervix uteri; but this is an uncertain symptom, and in a case described by Dr. Madge, in the *Obstetrical Transactions*, it was notably absent, as was also the pain in defæcation so commonly observed.

Among the occasional symptoms are blood in the urine; severe pains in the lumbar and sacral regions and down the limbs; œdema of the lower extremities and vulva; and, more rarely still, phlebitis in the crural veins produced either by pressure or blood poisoning. A still more exceptional symptom has been observed by some writers in connection with extraperitoneal hæmatocele, namely, an ecchymosed colour of the vagina; and in two cases ecchymosis of the abdominal wall.

The *progress* varies very much with the age of the patient, her condition of health at the time of the seizure, and the character of the attack. Sometimes the attack sets in with great violence and the progress is rapid. In the majority of cases the entire extravasation of blood takes place in a very short time from the commencement of the attack, although at first it may not be possible to define a tumour. In a few hours, however, or at least in a few days, the swelling is detected, and it may attain the size of a child's head, or of a gravid uterus at six months. When once formed it does not necessarily increase in size except in the cases of progressive hæmatocele. The suddenness of its appearance, and the rapidity of its full increase in size, are important points to be noted in distinguishing it from the results of pelvic cellulitis and other morbid conditions.

Instances present themselves in which the symptoms are less acute. Blood seems to be poured out in small and progressive quantities at certain intervals, creeping on as it were—the increase of swelling, in the menstrual cases more particularly, corresponding with the monthly periods. After the tumour has attained its full development—whether it has been formed rapidly or by progressive steps—the natural tendency, if not interfered with, is gradually to decrease in size. The tumour, at first soft and semi-fluctuating, becomes harder to the touch and of unequal density, and the sense of fluctuation gradually disappears. These alterations arise from the changes which take place in the extravasated blood; the serum becomes absorbed, while the coagulum remains and undergoes the changes observed elsewhere in blood-clots, growing harder and denser. The remains of the clot with the induration incident to the attendant pelvic peritonitis is often found months or years after the attack. It has been noticed by many authors that when once the tumour has reached its full development, and is no longer increased by the occurrence of the catamenial period, the menstrual flow seems to exert a beneficial effect. With each recurring normal period there is a marked decrease in size, the improvement taking place as it were by leaps instead of by gradual and continuous absorption. Voisin, Prof. Dolbeau, and Poncet dwell particularly on this feature. When menstruation is present at the onset of the attack the function may be suddenly checked, and only return after an uncertain interval. The rule is, however, that instead of being arrested, it becomes so profuse as to be a marked feature of the case;

and when restrained within moderate limits, often persists for weeks as a further drain on the strength of the patient.

When the case is not interfered with by injudicious surgical procedure, and suitable palliative measures are adopted, the natural tendency in all instances, except those which have been called cataclysmic, is for the more formidable symptoms to subside gradually. The effects of shock are recovered from, the pain and febrile signs decrease, and after a time the patient experiences only great weakness, with a train of symptoms more chronic in character, due to the presence of the mass in the pelvis, and more or less marked in accordance with its bulk and situation. There may be a sense of weight in the pelvis, bearing down, some difficulty in micturition and defæcation, and pain and discomfort in attempting to walk or assume the sitting posture. If one side of the pelvis be occupied by the tumour the nerves and vessels of the lower limb on that side may be compressed or irritated, and pain in movement may be experienced on the affected side only.

As a rule, therefore, recovery takes place slowly, by resolution; the blood and surrounding adhesions are gradually absorbed, and the damage done is ultimately repaired. This holds good even in the larger forms of hæmatocele, if let alone; supposing always that the blood mass is safely surrounded by limiting adhesions. In twenty-five cases noted by Voisin fifteen terminated by absorption. The average duration is found to be about four months. Braun, in twenty-four cases, noticed absorption to be complete in six months, and Bandl's figures point in the same direction; but one of his cases took six and another eight months to recover.

As in cases of cellulitis the recovery is sometimes a very slow one, and subject to many interruptions. The function of the pelvic organs may remain impaired for months or years after the attack, with indications of thickening around them, or perhaps of salpingitis or other affection of the tubes.

In a small proportion of patients suffering from hæmatocele, recovery does not take place by resolution, as in the more favourable cases, but suppuration occurs in the blood-cyst. The contents may then be evacuated by one of the pelvic canals. There is a divergence of opinion whether suppuration always precedes the evacuation of the cyst. The failure to detect pus in the discharges has been thought to indicate that simple ulceration of the containing walls may sometimes account for the evacuation, without any preceding suppuration. When suppuration does take place there is usually a reaccession of febrile symptoms, often preceded by rigors and attended by rise of temperature and profuse perspiration. If spontaneous evacuation occur, the patient passes a quantity of fluid and semi-solid material, which in appearance has been compared to currant jelly, and in odour to decaying flowers. In twenty-seven instances, cited by Voisin, six emptied themselves by the rectum, three by the vagina, and four burst into the cavity of the peritoneum. This last mode of termination (said by Pozzi to be rare, whether produced by

suppuration or not) is by far the most perilous, inasmuch as it is uniformly followed by general peritonitis and death. The danger of rupture into the peritoneal cavity is always increased by the occurrence of suppuration; hence the necessity of early artificial opening when once the fact of suppuration is beyond doubt. Bandl states that the most frequent exit in spontaneous evacuation is by the rectum, and this is not devoid of danger as it may set up exhausting diarrhœa. The opening not being in the most dependent part of the cyst, fœcal matter may find entrance, foul gases be formed, and septic materials generated which infect the whole system. These results are accentuated if more than one opening occur, and these may be into the rectum and vagina at the same time. When no general septic infection occurs the patient may be worn out by diarrhœa, persistent high temperature, impaired nutrition, and exhausting sweats.

Matthews Duncan dwelt on the importance of recognising the existence of fluid in the lowest part of the sac, in hæmatocele of some standing, as indicative of the presence of pus. He modified his opinion later, and taught that the mere presence of fluctuation, unless preceded by general and local signs of suppuration, is not sufficiently trustworthy, and is apt to lead to an erroneous conclusion. The secondary inflammation and suppuration of a hæmatocele, particularly if the indications of suppuration are so indistinct that artificial evacuation cannot be resorted to, may protract the recovery of a patient indefinitely. The formation of purulent matter at times takes place so insidiously that the first distinct proof of its existence is the discharge of pus and broken down coagula or coffee-ground-like material by the rectum. M'Clintock gives an example of a patient dying from a persistence of these exhausting discharges, and Madge a case in which a woman died from the combined effect of exhausting discharges and phlegmasia dolens.

Further, it appears that intercurrent peritonitis may complicate the progress of hæmatocele, and this apart from the rupture of the cyst. By this is meant that, after the first inflammatory action has subsided which formed the boundaries of the original blood-cyst, peritonitis more or less severe in character supervenes at times from slight causes during the progress of the case. These attacks may be severe or slight—general or partial in character: in all cases they entail further peril; and at no time during the persistence of the hæmatocele is there an immunity from their reappearance. Voisin observed this mode of fatal termination in one case as late as three months, and another at the end of four months after the date of the original attack.

**Diagnosis.**—The points of distinction between hæmatocele and other morbid conditions found in the female pelvis require very careful study. In an ordinary case there may be no great difficulty; but it should be borne in mind that mere physical examination, without careful investigation into the history of the invasion, and a review of all the subjective symptoms, is not sufficient.

- i. A suspension of the catamenia for one or more periods when they



have been heretofore regular, and symptomatic changes in the mammæ with other signs of pregnancy previous to an attack, may point to the rupture of a tubular or other form of extra-uterine pregnancy. Such cases are generally attended by very grave symptoms, as ordinarily the extravasation of blood into the peritoneum is so large that there is no opportunity for its limitation by adhesions, and the patient speedily dies from shock and peritonitis. And the cause of the catastrophe in these cases is not always easily ascertained. Such eminent authorities as Robert and Hugier both acknowledge that they have mistaken a blood extravasation produced by rupture of an extra-uterine foætation, and occupying a considerable space in the pelvis and abdomen, for pelvic hæmatocele arising from other causes. Death does not necessarily occur in all these instances. The effused blood, if not too extensive, may, together with the ovum, become surrounded by adhesions as in other forms of hæmatocele; and either be absorbed, or, if the ovum retain its vitality, continue its development in its new nidus. Possibly before the sudden invasion of illness a swelling may have been detected in process of extension on the lateral margin of the uterus. This with signs of early pregnancy clearly point to ectopic gestation.

ii. The affections which of all others bear the closest resemblance to pelvic hæmatocele in its chronic stages, and are most likely to be mistaken for it, are the various forms of pelvic cellulitis, pelvic peritonitis, and the after stage of pelvic abscess. The formation of a correct opinion is often most difficult; and, at some stages, without the aid of a succinct history which is not always forthcoming, well-nigh impossible. Even with a clear history the differential diagnosis is frequently by no means easy. It may aid discrimination to remember that attacks of pelvic cellulitis are more frequent than hæmatocele. Pelvic inflammation and abscess are more frequently consecutive to abortion and delivery; or, when not so, have generally some relation to a previously existing inflammatory condition in the uterus or ovaries: they are not generally accompanied with menorrhagia, they are not attended by rapidly produced pallor of the skin and anæmia, and the swelling, if watched throughout its course, is more likely to begin in the lateral and deeper parts of the pelvis, is comparatively slow in formation, and is hard from the first. If suppuration occur, it becomes soft and fluctuating later. Hæmatocele, again, is more commonly connected with some accident of menstruation, and reaches its greatest intensity suddenly; the tumefaction is more frequently behind the uterus; it is soft in its early stages, and grows harder as time passes on, beginning to fluctuate again if the cyst inflames and suppurates.

A further point of difference is that, in hæmatocele, if the swelling be at all considerable, it is more or less rounded in form, with hard inflammatory margins; and it displaces the uterus in accordance with the position of the blood swelling, but commonly forwards in the intraperitoneal form, with the neck carried high above the pubes. In pelvic inflammation, properly so called, the fibrinous deposit is infiltrated



through the pelvic tissues affected, fixing the uterus more or less in its normal position so that it cannot be elevated or depressed. When cellulitis is extensive it fixes all the viscera in the pelvis to the osseous boundaries, as if plaster of Paris had been poured into the pelvis and had hardened there. Again, the constitutional symptoms follow an inverse order in the two affections — febrile disturbance distinctly precedes the formation of tumour in the inflammatory affection, it follows it in hæmatocele.

These distinctions refer more particularly to the early or acute stages of the affection. When a case is seen for the first time in the chronic stage — that is, a considerable time after the supervention of the original attack — it may be more difficult to determine its true nature. The presence of tumour or thickening in the pelvis may, of course, be due either to previous cellulitis or peritonitis; or it may primarily have its origin in an extravasation of blood upon which inflammatory action has supervened. It is only by a careful study of the history of the attack that the difficulty can be solved. It may be equally difficult to determine, when a patient is not seen until suppuration has occurred, whether abscess be the result of primary phlegmonous inflammation or be the secondary product of a suppurating hæmatocele. Fortunately the treatment in the two cases is practically the same, and the patient suffers no disadvantage from a failure to decide concerning these perplexing difficulties.

iii. Voisin and others have stated that the diagnosis between hæmatocele and inflammation of the ovary with its products is often very difficult. The degree of difficulty will vary, of course, with the stages at which the patient comes under observation; but ordinarily there will be no great difficulty in discriminating between the two. The points of difference are the limitation of pain and swelling, in the earlier stages of ovaritis, to the locality of one or other ovary, and a certain amount of febrile disturbance in the incipient stage.

When a considerable swelling has formed as a consequence of a long and intense attack of ovaritis, which has extended to surrounding parts and become complicated with pelvic cellulitis and peritonitis, it should be noted that there has been no sudden invasion or rapid formation of a tumour, as in hæmatocele; no sudden anæmia; perhaps no coincident menorrhagia; and the symptoms gradually increase in severity from the commencement, while in hæmatocele the most severe symptoms appear from the first, and as time passes, undergo gradual amelioration.

iv. The various forms of uterine and ovarian tumour of limited size, beyond the remote resemblance on physical examination, would seem to have very little in common with hæmatocele. Yet Asch reports a case where a supposed hæmatocele was punctured through the vagina, and was found to be an ovarian cyst which was afterwards successfully removed. Tumours are to be distinguished by the absence of urgent symptoms from the commencement, by their slower growth, circumscribed form, and generally by their mobility. An ovarian tumour is commonly

lateral in position, and, if it sinks into the uterine *cul-de-sac*, it is rarely, as M'Clintock has pointed out, so low as blood gravitating there from the peritoneal cavity. A more perplexing situation arises if an ovarian cyst, prolapsed behind the uterus, inflames and suppurates, or possibly ruptures there. Inflammation of the cyst, which does not proceed to suppuration, may throw out lymph deposits which mask the rounded form of the original tumour, and thus the softer centre with harder margins may simulate the physical characters of hæmatocele. The diagnosis might be still more obscured by œdema of the recto-vaginal septum, which, when inflammatory action goes on in the posterior *cul-de-sac*, may at any time thrust forward the posterior wall of the vagina, and lead to a sense of fluctuation there. The only way out of these difficulties is to study the history carefully and to watch the progress of the case. In the lapse of time, as inflammatory action subsides, it may be observed that the serous and lymph effusions are absorbed, while the central tumour remains. If this is fluctuating and unattended with constitutional signs of suppuration, it is pretty certain to be ovarian. If suppuration take place in an ovarian cyst so placed it is usually, but not always, attended by characteristic constitutional signs. In all doubtful cases, where it is of importance to ascertain the true nature of the fluctuating swelling, recourse may be had to an exploring needle or aspirator as recommended by Sir James Simpson and Professor Braun.

Sudden and profuse hæmorrhage into the cavity of a large ovarian cyst may be attended by some of the general symptoms of hæmatocele. There would be the indications of internal hæmorrhage in both cases, with the production of rapid anæmia. Fortunately such cases are not frequent, as the distension of ovarian cysts by other contents exerts a restraining influence against large blood extravasations into them. Still, as before mentioned, death has resulted from this cause and the diagnosis may be difficult. In the ovarian hæmorrhage there would probably be the history of a previously existing tumour; and the uniformity and smoothness of its surface and the absence of swelling in the recto-uterine pouch, should lead to a correct conclusion.

Fibrous tumours of the uterus, as a rule, bear no sort of resemblance to hæmatocele, either in their history or physical characters; but seeing that such experts as Malgaine and Stoltz have mistaken them for hæmatocele, it may be well to say a word or two on the differences. Malgaine and Stoltz both attempted to remove tumours, supposed to be fibroids of the uterus, which proved to be retro-uterine hæmatocèles, and both cases ended fatally. Beyond the fact that the two affections are commonly attended with hæmorrhage there are not many points of similarity. Fibroids of the uterus are distinguished by their history of slow, painless growth, by their density, by their position, and by their attachments to the uterus. There is no sudden production of anæmia. Yet uterine fibroids, particularly if situated behind the uterus, may give rise to sudden attacks of pain arising from inflammation; and the difficulty of determining whether a pelvic tumour

is solid or has fluid contents should not be underrated. A distended pelvic cyst may feel so hard and dense as to simulate solid growth; a fibroid, on the other hand, may be so soft, particularly if previously inflamed, that it may seem to have fluid contents. The only way of making an accurate differential diagnosis in doubtful cases of this nature is by the use of the aspirator or exploring needle.

Of malignant growths in the pelvis probably only encephaloid tumours, which are rare, run any chance of being mistaken for hæmatocele. As they may be attended with the general aspect and pallor so constantly observed in hæmatocele, there is a possibility of error; but the gradual development of the malignant growth, and the supervention of anæmia and waxiness in the skin, with other indications of the cancerous cachexia, in the later rather than in the earlier stages of the affection, would be sufficient distinctions. Dr. Playfair has recorded an instance where hæmatocele was produced by the bleeding of malignant growths in the peritoneum, and became one of its secondary complications, increasing the difficulty of diagnosis.

v. Retroflexion and retroversion of the gravid uterus, particularly those forms in which the symptoms appear suddenly from violent efforts or accident, are said to have been occasionally mistaken for hæmatocele. The cervix uteri in both cases may be so displaced upwards and forwards as almost to be out of reach of the finger; and when there is a suspicion of pregnancy the sound cannot in prudence be used to aid diagnosis. To arrive at a correct conclusion it will probably be enough to note that, in the case of a displaced gravid uterus, there has been a suspension of menstruation, characteristic changes in the breasts, and other symptoms of pregnancy; the retro-uterine tumour is circumscribed and smooth, without hard adhesions on its borders; the cervix uteri has a partial mobility, and can be traced backward to the swelling behind, while there is an absence of all tumour above the pubes. In some instances the fundus may be raised up with the finger in the posterior vaginal fornix or in the rectum. On the other hand, whenever hæmatocele is of considerable size, it can probably be felt above the pubes, and the whole uterus can be traced lying in front of it. The value of signs connected with the mobility of the womb, empty or gravid, would necessarily be vitiated where old adhesions bind it backwards, and perhaps make the outline of the fundus irregular from the deposits about it. In the unimpregnated uterus the use of the sound would show the direction of the uterine cavity and the position of the fundus. In the gravid organ the history, more particularly the early symptoms of pregnancy, would in most instances be sufficient to indicate the nature of the case.

vi. Faecal accumulations in the rectum are to be distinguished from hæmatocele by noting that ordinarily they can be indented by the finger pressing through the vaginal wall. If harder, a digital exploration of the rectum will reveal their true nature.

vii. The difficulty in distinguishing between the intraperitoneal form of hæmatocele and the extraperitoneal (hæmatoma of authors) is

admitted. Frankenhäuser and Bandl suggest, as a solution, the placing of the patient in the knee-chest position before the blood becomes encapsulated by adhesions; then, if in the peritoneum, it will flow out of Douglas' space, and return again when the patient assumes the dorsal position. Posture would not affect the hæmatoma. This is a test which must have a very limited application, and is scarcely to be recommended; for besides the difficulty of attempting it with a patient in a state of collapse, it would tend to prevent the desired encapsulation of the effused blood, and extend the peritonitis. The points to be noted are the more usual lateral position in hæmatoma — displacing the uterus to the opposite side; the bulging round the uterus, not confined to the pouch behind; the less degree of shock and collapse than in intraperitoneal hæmatocele, and the delay of the inflammation. The mass is unlikely to be so large as to displace the uterus upwards and forwards as it does when the hæmorrhage is intraperitoneal.

viii. Serous effusion into the pelvic cellular tissue, associated with some of the low forms of pelvic inflammation, may be a further source of confusion in diagnosis. Crédé of Leipzig tapped a tumour of uncertain origin and got serum first, then blood-stained serum, and finally blood. If the swelling fluctuate, only the history and use of an aspirator can clear up its nature. Sir James Simpson and Sir John Williams have both noted this serous effusion in the pelvic cellular tissue, and it was pointed out as a source of fallacy by myself in the article "Hæmatocele" in Reynolds' *System of Medicine*.

The prognosis depends much upon the extent of the hæmorrhage and the gravity of the attendant symptoms in particular cases. In the majority of instances, if the right treatment be adopted, and the medical man can be persuaded to abstain from hurtful surgical interference, the prognosis is favourable. Dr. F. Weber of Berlin, a careful writer on this subject, states that of twenty-three cases observed by him none were fatal, — a result he ascribes to his method of treatment, which is the application of an ice bladder, perchloride of iron internally, and avoidance of puncture. Poncet, again, is emphatic in holding that recovery is the rule if no surgical interference be practised. These authors would probably, however, except cases where blood extravasation is so large as not to become encysted, and also ruptures of ectopic pregnancies. In all cases there must be a degree of uncertainty; for when vascular rupture has taken place in the pelvis, it is impossible to foresee to what amount the hæmorrhage may extend; or, when once apparently checked, whether there shall be a renewal to a fatal amount. There are, besides, the dangers arising from subsequent peritonitis, which may overwhelm a feeble patient; and from the liability to low forms of chronic peritonitis, creeping on in patients not seemingly in immediate peril, with a tendency to aggravation at the catamenial periods. To these may be added the drain upon the strength when a cyst suppurates and discharges through the bowel or vagina. The incessant diarrhœa and hectic so set up not unfrequently have exhausted the vitality of a patient who has survived a



primary attack; and, if the contents of the intestine get into the sac, they may favour the absorption of septic materials and general blood poisoning. Again a suppurating cyst may burst into the peritoneum, and speedily be followed by a fatal result. Lastly, if a patient escape the effects of the original attack, and also the risks of suppuration, she is apt to be long in a condition of incomplete recovery with the pelvic organs more or less fixed, the tubes and ovaries possibly occluded, and a certain amount of hardness from deposit surrounding the uterus. The chronic persistence of this deposit, while it lasts, not only may interfere with the normal function of menstruation, but be a permanent cause of sterility. It must, nevertheless, be repeated that the general tendency is towards recovery, if the effects of the primary attack are surmounted; also that the absorption of the products left behind may be complete.

**Treatment** may be considered first as preventive or prophylactic, and therapeutic or actual when once an attack has occurred. The therapeutic treatment may again be divided into treatment of the primary attack and the treatment of its consequences.

*The prophylactic treatment* consists in guarding those who may be most liable to hæmatocele from the exciting causes of its development. The women of some families seem more prone to it than others; and therefore, if one member has suffered in this way, her sisters should take precautions, more especially if liable to certain symptoms which seem associated with its production. Thus women who suffer from dysmenorrhœa, particularly in the congestive form; or in whom, from any obstruction, the escape of the menstrual flow is difficult, should be warned to observe rest and the recumbent posture during the catamenial period. In the intervals they should be submitted, if practicable, to treatment of the painful and difficult menstruation. Women who have varicose veins of the lower extremities, of the vulva, or of the rectum, in the form of hæmorrhoids, and the like, and who menstruate therewith painfully and with abnormal profuseness, should likewise keep the recumbent position during the periods, and avoid all the causes which have been known to provoke hæmatocele. Particularly they should avoid travelling, over-exertion or exposure to cold during menstruation; coitus should be interdicted altogether near the catamenial period, and at other times practised moderately and without violence.

*When an attack has occurred*, the medical man will in the first place have to treat the patient in the stage of shock, and in doing so will have to consider the pathological cause. The object should be to palliate the symptoms of collapse, and to restore the depressed vitality of the patient without doing anything which would tend to increase the extravasation of blood. Non-encysted extravasations, whether arising from the rupture of an extra-uterine fœtation or from some other cause, are as a rule so speedily and certainly fatal that all palliative treatment is likely to be useless, and the question of laparotomy pushes itself inevitably to the front. This will be discussed later. Since, however, there

are at first no means of accurately ascertaining the extent of the blood effusion — either at the moment or prospectively — nor the probability of its becoming encysted, the rational plan of treatment consists in sustaining the strength of the patient, relieving the pain, and adopting such measures as are likely to stay the flow of blood, to promote its coagulation, and to limit it in such fashion that it may become encysted by subsequent adhesions. These general indications apply both to the extra- and intraperitoneal forms, but are the more urgent in the latter.

The first thing, therefore, is to ensure at once absolute repose in the recumbent posture, to impress upon the patient the importance of restraining restlessness and impatient movements and of avoiding all mental emotion or other disturbance of the general circulation. A full dose of opium or morphia will have the double effect of soothing the pain and restlessness, and of lessening the depressing effects of loss of blood; sinapisms may be applied to the upper extremities by way of diverting the circulation in that direction. In cases of extreme collapse the hypodermic injection of ether may be employed, and a solution of common salt (a teaspoonful to a pint of boiled water) may be injected into the veins or into the rectum, as may be more practicable. Some French authors have recommended that, in the early stage, venesection should be practised once or twice, to produce a derivative effect on the pelvic vessels, and to lessen the pressure in the systemic circulation generally, and on the internal bleeding points more particularly. Aran recommended twenty or thirty leeches over the abdomen on the first day, fifteen to twenty on the second, and twelve to fifteen on the third day, if the constitutional condition of the patient would bear it and the feebleness were not too great. He testified to the favourable results of such treatment, and to the shorter duration of the cases. He supported the strength during depletion by nutritious diet, and followed up the leeching by blisters and other forms of counter-irritation to the abdomen. Neither general nor local depletion has found favour in Great Britain.

The local application which has been found most effective is an ice-bag over the hypogastrium; or, if ice cannot be procured, cold compresses over the seat of pain. Hot fomentations and poultices are to be sedulously avoided lest, in the attempt to relieve pain by their use, they should promote the further flow of blood internally. The diet should be simple, unstimulating, only enough to prevent exhaustion; and all drinks should be cool or cold, so that the circulation be not suddenly stirred. For the same reason if brandy or other stimulant be given — and this may be urgently needed — it should be given only in small quantities frequently repeated. Various astringents and hæmostatics may be administered if thought desirable — sulphuric acid, tannic or gallic acid, acetate of lead, perchloride of iron, ergot (by hypodermic injection), digitalis, etc. Whichsoever the agent chosen it may be well to combine it with opium. When the symptoms of shock have subsided, and the period of reaction sets in, it becomes necessary to prescribe for the febrile symptoms, and to combat the signs of local peritonitis. Frequent vaginal

or even external examination should be avoided, especially with the sound or other instruments, as disturbing to the patient and likely to interfere with the integrity of the adhesions forming round the extravasated blood. For the same reasons the use of purgatives should be avoided. The urine should be drawn off with a catheter, and every movement or disturbance of the patient obviated as much as may be. The main points to be attained are absolute repose and the relief of pain by opium or morphia, which may be administered by the mouth, rectum, or hypodermically as seems most expedient. If thought desirable the ice-bag can be continued, as it may relieve pain and lessen the intensity of the peritonitis. If the signs of local peritonitis are very severe, and the patient's strength will bear it, the application of a few leeches to the hypogastrium or anus may now be an advantage; but they cannot be applied to the cervix uteri without more disturbance than is desirable. Leeching, with hot vaginal douches, as recommended by Bernutz and Goupil, are less objectionable at a later stage. These Bernutz advises at the approach of a catamenial period both to promote the flow, and to facilitate the absorption of the pelvic tumour.

In regard to the *surgical treatment* of the primary attack there has been great fluctuation of opinion; but the matter seems now to be settled absolutely in favour of non-interference in the extraperitoneal form, and also in a large proportion of intraperitoneal cases. The exceptions to this rule, more particularly in the last-named class, are those instances where the quantity of blood effused, whether it result from the rupture of an abnormal pregnancy, or from some other cause, is obviously so large or continuous that there is little chance of its becoming successfully encysted; and the patient is evidently doomed if left to the natural powers of recovery. In such instances, probably the only chance of saving the patient is the performance of laparotomy at once, or as soon as the first rally from shock will permit, and the securing of the bleeding points, with the removal of the clots. Could we be certain of the diagnosis in cases of rupture of tubular and other forms of extra-uterine gestation, there would no doubt be a consensus of opinion as to the propriety of opening the abdomen as soon as practicable after the occurrence of the "cataclysmic" or "dramatic" symptoms so rapidly supervening. For not only is there the risk of one attack of hæmorrhage succeeding another, but there is the danger of the ovum becoming necrosed in the peritoneal cavity, and producing septic infection; or possibly, if the patient recover, of the continued development of the ovum either in its original abnormal seat, or in some other locality to which it has been transplanted. In these latter circumstances a primary operation would be but to anticipate what most probably would be required later. Unfortunately accurate diagnosis is frequently so little assured that the question of operating must be determined rather by the urgency of the symptoms than by the pathological cause. If doubt exists it is wise to abstain from surgical interference, for not only have large extravasations of blood producing voluminous intra- and extraperitoneal tumours been entirely resolved,



but there is reason to believe that ova extruded into the peritoneal cavity may occasionally be absorbed, and thus give no further trouble.

The rule of non-interference by primary surgical procedure in other cases than those associated with abnormal pregnancy has been evolved from the experience of many authorities. Nélaton at first employed the method of puncture and evacuation in all cases indiscriminately. In several instances where puncture was practised the patients were attacked with purulent infection and died. This led to a modification of treatment, and artificial evacuation was resorted to only when the symptoms were urgent. Later Nélaton taught that surgical interference was only warrantable when such threatening symptoms were present as to cause apprehension of rupture of the adhesions forming the parietes of the cyst, and extravasation of the contents into the general peritoneal cavity. Thus where a hæmatocele of considerable size already existed, and appeared to be increasing in size—being attended by constant and violent pain—he concluded that secondary inflammation was going on in the cavity, and that the cyst walls would probably give way, and fatal peritonitis be the result. The statistics of Voisin, published in his excellent monograph, although not now recent, were decidedly adverse to artificial evacuation as a general plan of treatment, and led him to prefer an expectant method, unless the case were exceptional and threatening. Thus out of twenty cases where surgical interference was resorted to, fifteen recovered and five died. In contrast with this, out of twenty-seven cases treated by the expectant method, twenty-two recovered and five died. Deducting from the last class two deaths in which hæmatocele was apparently not the immediate cause of death, the mortality, when no operation was performed, was one in nine, but was one in four when an artificial opening was made. Voisin's statistics were probably too limited to form a trustworthy guide, and these are sources of fallacy which must be guarded against. Thus it does not appear whether the cases operated upon and chronicled by Voisin were slight or severe. He was a pupil and follower of Nélaton, and therefore it is probable that some of Voisin's cases treated by puncture were instances of the worst form, and that an opening was imperatively called for by the severity of the symptoms. The results tabulated by West show that of fifty-five cases treated on the expectant plan forty-three recovered and twelve died, while of forty-eight cases of surgical interference forty recovered and eight died. Here again sources of fallacy may lower the value of the statistics, unless it be clearly shown whether the cases operated upon were of such gravity that they could not safely have been left to the expectant method.

Meadows boldly advocated a more frequent recourse to puncture in cases where the quantity of blood effused was, comparatively speaking, inconsiderable in amount. He made use of Voisin's statistics in support of his contention. At the time there was no great difficulty in showing that the figures relied upon by Dr. Meadows were untrustworthy, because sources of fallacy were not



sufficiently eliminated; and both opinion and practice in later days have steadily veered towards a more conservative method, even in cases deemed to be intraperitoneal. Following the precepts of Nélaton, such later writers as Thomas, Gusserow, Pozzi, and others, only recommend surgical interference in serious cases, each of which is to be judged by its individual peculiarities. Auvard goes so far as to say that nineteen out of twenty cases of hæmatocele will end well by simply ensuring repose in bed. In striking contrast to this is Lawson Tait's opinion that nearly all cases are fatal if not operated upon. He, however, looks upon almost all cases of intraperitoneal hæmorrhage as due to tubal pregnancy, and has been in the singular position of seeing none other.

No division of opinion exists as to the right course to pursue in the later stages of hæmatocele. When indications of suppuration are once clearly established, artificial evacuation should be undertaken as soon as practicable; not only by way of obviating the possible catastrophe of the suppurating cyst bursting into the peritoneal cavity, but also with the object of securing a drainage more favourable to the recovery of the patient than if the abscess be left to spontaneous rupture. It has been pointed out that spontaneous evacuation of hæmatocele is apt to take place through the intestine, because a larger surface of the bowel is surrounded by the tumour than of the vagina, uterus, or bladder. This is not nearly so favourable an exit as by the vagina, where drainage may be established without setting up the irritation which by the rectum is inevitable. Evacuation should therefore always be made by the vagina when possible. There may be a certain number of cases where, notwithstanding the presence of general signs of suppuration, fluctuation cannot be felt by the vagina. In these instances exploration must be made by the rectum as well as by the vagina, and the question of opening be determined by the result. Thanks to the modern use of antiseptics, both abdominal sections and artificial evacuation can now be undertaken with less risk of septic infection than in former days. The admission of air into the sac, setting up putrefaction, the recurrence of secondary peritoneal inflammation, and the renewal of hæmorrhage, were common results in former times when incisions or puncture were practised either before or after suppuration. The dangers of operation, nevertheless, are multifarious and not lightly to be encountered. A patient under the conjoint care of Malgaigne and Nélaton died of hæmorrhage from a posterior uterine artery which was wounded by puncture; and a patient operated upon by Hugier died of peritonitis provoked by injecting warm water to wash out the contents of the cyst. Recent results happily testify that operations on hæmatocele, when imperatively called for and carefully conducted, are somewhat less perilous than at one time they appeared to be. Matthews Duncan, a careful observer and a decided conservative in reference to operations, and Professor Braun, both testify to the truth of this statement. Both observed a shorter duration and more rapid cure after artificial evacuation in appropriate cases than they expected. Improvement in the result of operations is partly to be attributed to the

better selection of cases, partly to the nature of the operation, and largely to the introduction of antiseptic precautions. In the earlier operations puncture of the sac by a trocar was chiefly practised; and this, while it allowed the admission of air, probably carrying germs of disease with it, relieved the tension, but did not ensure free drainage or the exclusion of clots. Sir James Simpson long ago recommended, instead of puncture, a freer opening with a tenotomy knife, and gradual enlargement with the fingers, so as to lessen the chance of wounding large vessels, and to permit more solid matters to be discharged. This larger opening by the knife is now generally admitted to be the best practice: in addition to other advantages it permits the more efficient antiseptic treatment of the cavity, which can then be stuffed with iodoform gauze to obviate the formation of septic products within. The gauze must, of course, be introduced with great gentleness, and under no circumstances should fluid be injected, lest the fragile adhesions forming the cyst boundaries towards the peritoneum be broken down. An opening by the vagina may not always prevent a spontaneous opening in another direction. In a case of Dr. West's, puncture by the vagina was followed by an opening into the bowel; hence, if spontaneous evacuation by the rectum seem inevitable from pointing in that direction, it may be best to open artificially there, notwithstanding the disadvantages named. The question arises, nevertheless, whether, if fluctuation in any degree can be detected by the vagina, it may not be well to make an incision there, even if discharge have already appeared by the rectum; as the counter opening will prevent the retention of faecal and other contents in the abscess cavity.

In summary, it may be stated that as a general rule it is best to treat cases of hæmatocele — intraperitoneal as well as extraperitoneal — by a palliative method, relieving the symptoms by appropriate remedies, and taking such precautions as are likely to ward off fresh complications. When the blood extravasation is extraperitoneal no need to deviate from this plan is likely to arise, but it should be pursued as far as possible irrespective both of the size and position of the hæmatocele; and in a large proportion of cases, if perfect quiescence be enforced, the tumour, even if of considerable dimensions, will gradually disappear. If, however, the symptoms are very severe, or the tumour once formed, instead of subsiding, shows a tendency to increase, with repeated recrudescence of urgent symptoms, it becomes a question whether, notwithstanding the risks, laparotomy should be performed for the double purpose of removing the contents of the tumour and securing the bleeding points. In the cachectic cases there would be less hope of doing good by operation than in others; each case must be judged on its own merits. Again, whenever in the after stages of the affection constant and severe pains, the occurrence of rigors, and marked increase of temperature at nights, with other hectic symptoms, indicate that suppuration has taken place, then artificial evacuation, by the vagina if practicable, becomes imperative as soon as fluctuation can be detected. In some rare cases, where no distinct signs

of suppuration have occurred, the urgency and persistence of certain severe symptoms may yet call for operative interference. Thus the persistence of severe and chronic vomiting, which has been observed associated with large hæmatoceles, and continued and alarming obstruction of the bowels, as observed by Meadows and others, may call for some diminution in the amount of physical pressure. In such instances Routier, who at one time preferred laparotomy, has declared his preference for vaginal incision as less hazardous; and his position is supported by Zweifel, von Strauch, and other authorities. Regnier, again, prefers abdominal section, but his preference should be regarded with caution, as he would extend abdominal section to cases treated by others on the expectant plan. If there be reason to suppose that hæmorrhage is still going on within, and that the boundaries of the blood-cyst are not consolidated, probably the least hazardous course would be to perform laparotomy rather than make an incision by the vagina. This operation is the more to be preferred where there is a suspicion that the case is associated with ectopic gestation. As to the technique of this operation, Pozzi says that "the sac should, if possible, be fixed to the abdominal wall by 'marsupialisation,' emptied, plugged, and drained. But this theoretical manœuvre is rarely practicable on account of the absence of a well-formed and resistant cyst wall; the latter generally has no individuality, and is simply formed by adhesion of neighbouring parts. The surgeon may then be forced to content himself with antiseptic flushing of the cavity." It is obvious, however, that this flushing must be of the gentlest character, lest the temporary adhesions be broken down. In such a case it would be wise to plug the orifice with iodoform gauze, and provide capillary drainage.

The after treatment of hæmatocele in its more chronic forms, and more especially in cases not operated upon, deserves careful attention. The indications are to prevent as far as possible the recurrence of hæmorrhage or other active symptoms, and to promote the absorption of the extravasated blood with the inflammatory products surrounding it. It is necessary, therefore, at the catamenial periods to prescribe absolute rest in the recumbent position until recovery is completed; in the intervals the amount of exertion should be carefully regulated. Violent efforts or straining should be avoided, as well as all excitement of the sexual organs. The bowels should be made to act easily, and the diet should be nutritious, but not over-stimulating. If there is anæmia, and this associated with dribbling bloody discharge from the uterus, acid chalybeates, such as the sulphate or perchloride of iron, combined with mineral acids and other tonics, may be prescribed. The iodides and bromides of iron have been found useful in promoting the absorption of deposit and thickening if they continue long after an attack; and these may be aided by the local application of blisters, tincture of iodine, and mercurial and belladonna ointments. Sir James Simpson used vaginal suppositories or pessaries medicated with iodides and mercurials for this purpose.



The precautions to be adopted when spontaneous evacuation has taken place will depend on the locality of exit. If opening has taken place per vaginam, then probably all required will be strict antisepsis and generous diet. If perforation has been through the intestine, in addition to tonics and good food, opium or morphia may be required to stay the diarrhœa, and such precautions as are possible to ward off the tendency to recurring peritonitis and septicæmia. The question of counter-opening into the vagina may arise in such cases, particularly where the symptoms are grave, and there seems a likelihood of reaching the most depending part of the sac through the genital canal.

As the patient, even when fairly recovered, may still have indications of impaired health, deranged menstruation, and possibly of deposit remaining in the pelvis, care and precaution will be required for a prolonged and indefinite period. The avoidance of great exertion or of much travelling should be enjoined, and rest at the monthly periods. Change of air should be prescribed if it can be procured, and every advantage which, by improving the general health, will conduce to full recovery.

W. O. PRIESTLEY.

#### REFERENCES

1. *Amer. Syst. of Gyn.* Ed. by Mann, 1887.—2. ASCH. *Cent. f. Gynec.* 1887.—3. AUVARD. *Traité prat. de gyn.* 1894.—4. BALDY. *Text-Book of Gyn.* 1894.—5. BANDL. *Billroth's Handbuch*, 1879.—6. BARLOW. *Edin. Med. Jour.* 1841.—7. BARNES. *St. Thomas' Hosp. Reports*, 1870; and *Obstet. Trans.* vol. xiii. etc.—8. BERNUTZ. *Archives de médecine*, 1848; and *Diseases of Women*, by Bernutz and Goupil, Syden. Soc. ed.—9. BIEGEL. *Arch. f. Gyn.* 1877.—10. BOURDON. *Revue médicale*, 1841.—11. BRAUN. *Weiner Med. Wochenschr.* 1861.—12. BRESLAU. *Monat. f. Geburt, etc.* vol. ix.—13. BYRNE. *On Pelvic Hæmat.* 1862; and *Obstet. Soc. New York*, 1888.—14. CRÉDÉ. *Monatsschrift f. Geburt und Kind.* vol. ix.—15. CULLINGWORTH. *Obstet. Trans.* 1890.—16. DOLBEAU. *Med. Times and Gazette*, 1873.—17. DUNCAN, MATTHEWS. *Edin. Med. Jour.* 1862 and 1865.—18. EMMET. *Principles and Pract. of Gyn.* 1884.—19. ENGELHARD. *Archiv. de médec.* 1857.—20. FÉNERLY. *Thèse inaugurale*, 1855.—21. FERBER. *Arch. f. Heilk.* 1862, No. 5.—22. FOLLIN. *Gazette des hôpit.* 1855.—23. FRITSCH. *Volkmann's Sammlung*, No. 56.—24. GALLARD. *Union médicale*, 1855; *Gaz. hebdom.* 1858.—25. GOUPIL. *Syd. Soc. Trans.*—26. GUÉRIN. *Clin. Lect. Dis. of Female Gen. Org.* p. 439.—27. GUSSEROW. *Arch. für Gyn.* 1866-67.—28. HUGIER. *Lecture before Surg. Soc.*, Paris, 1851.—29. IMLACH. *Brit. Med. Jour.* 1885 and 1886.—30. LABORDIE. *Gazette des hôpit.* 1854.—31. LAUGIER. *Comptes rendus*, vol. xl.—32. M'CLINTOCK. *Diseases of Women*, 1865, etc.—33. MADDEN. *Dub. Jour. Med. Sci.* 1892.—34. MADGE. *Obstet. Trans.* vol. iii.—35. MARTIN. *Das extra-periton. peri-ut. hæmatom.* 1881.—36. MEADOWS. *Obstet. Trans.* vol. xiii.—37. MONOD. *Bull. de la Soc. de Chir.* 1851.—38. NÉLATON. *Gazette des hôpit.* 1851.—39. NONAT. *Traité prat. des mal. de l'utérus, etc.* 1874.—40. OLSHAUSEN. *Archiv f. Gyn.* 1870.—41. PHILLIPS. *Obstet. Trans.* 1887.—42. PIOGEY. *Bull. de la Soc. Anat.* 1850.—43. PLAYFAIR, W. S. *Obstet. Trans.* 1884 and 1889.—44. PUNCET. "Hæmatocele," *Diet. encycl. de méd. sc. méd.* 1886; *Hæmatocele péri-utérine*, Thes. 1877.—45. POZZI. *Treatise on Gynæcol.* Syd. Soc. 1893.—46. PRIESTLEY. Art. "Hæmatocele." *Reynolds' System of Med.* 1879.—47. PUECH. *De l'Hæmatocele péri-utérine et de ses sources.* Montpellier, 1858.—48. RÉCAMIER. *Lancette Française*, July 1851.—49. REGNIER. *Bull. Soc. de méd. prat.* 1892.—50. ROUGET. *Jour. de la Physiol. de l'homme, etc.* 1858.—51. ROUTIER. *Annal. de gyn.* July. 1890.—52. SCANZONI. *Diseases of Women.* American edit.—53. SCHROEDER. *Handbuch der Krank. etc. etc.*, und *Arch. f. Gyn.* Bd. v.—54. SEYFERT. See Tuckwell's Essay.—55. SIMPSON, Sir J. Y. *Diseases of Women.*—56. SUTTON. BLAND. *Med.-Chir. Trans.* 1890.—57. TAIT, LAWSON. *Diseases of Women*, 1889.—



53. TARDIEU. *Annal. de hygiène*, published 1854. — 59. THORNTON, KNOWSLEY. *Obstet. Trans.* 1889. — 60. TILT. *Diseases of Women*. — 61. TUCKWELL. *On Effusions of Blood in the Neighbourhood of the Uterus*, 1863. — 62. VEIT. *Centralblatt für Gyn.* 1891. — 63. VELPEAU. *Recherches sur les cavités closes*, 1847. — 64. VIGUÈS. *Des Tumeurs sanguines de l'excav. pelv.* 1850. — 65. VOBBERK. *Bull. de la Soc. de Chir.* 1851; and *Gazette des hôpît.* 1855. — 66. VOISIN. *De l'Hématocèle rétro-utérine*, 1858. — 67. VON STRAUCH. *St. Petersburger Med. Wochen.* 1891. — 68. WEBER, F. *Berlin. klin. Wochen. Chir.* No. 1, 1873. — 69. WEST. *Diseases of Women*. — 70. WILLIAMS (SIR JOHN). "Serous Perimetritis," *Trans. Obstet. Soc.* 1885. — 71. WINCKEL. *Die Path. der Weibl. Sex. Org.* 1881; and *Lehrbuch der Frank*, 1892. — 72. ZWEIFEL. *Arch. Gyn.* Bd. xxii.

W. O. P.

## BENIGN GROWTHS OF THE UTERUS

THE uterus is undoubtedly the most common seat of new growths in the human body. Exact statistics as to their relative frequency cannot be quoted; indeed, precise statistical evidence of the relative frequency of neoplasms generally must be untrustworthy. From the researches of v. Gurlt however, compiled from the Vienna Hospital Reports, which embrace 15,880 cases of tumour, females exceeded males in the proportion of seven to three; and of this large majority in the former, uterine growths accounted for 25 per cent, while the other sexual organs, including the mamma, contributed about 20 per cent.

The cause of this great frequency of new growths in the uterus is unknown; but when we consider the variety of its tissues, its constantly recurring periodic engorgements, and the enormous hypertrophy it undergoes during pregnancy, we may anticipate its special proneness to disease, and in particular to neoplasms.

That these conditions enter into the causation of the new growths is proved by the extreme rarity of congenital growths, and by the infrequent development of neoplasms before puberty; also after the menopause simple tumours rarely occur, and the malignant kinds in the great majority of instances are found in women who have previously borne children, and may be favoured by the bruising and laceration consequent upon parturition.

Simple tumours, especially fibroids, were supposed to be more common in the coloured races; but this assertion has lately been contradicted.

Easy circumstances seem especially to be associated with the development and growth of uterine fibromyoma, in contradistinction to the preponderance of uterine cancer in the poor and badly nourished.

The classification of uterine growths of a simple character may be most practically and simply considered by dividing them into two primary groups: (A) tumours of the muscular wall, and (B) tumours of the mucous lining.

**A. Tumours of the Muscular Wall** are practically represented by

one variety, the fibromyoma; these tumours, however, may undergo a large number of secondary changes that so transform their original structure, that one is tempted to describe them severally as independent types of neoplasm. Some growths, such as the cystic, may occasionally, no doubt, develop as such; but in the absence of definite proof of this, and on account of their extreme rarity, it is more simple and practical to attribute them entirely to secondary changes in pre-existing fibroids.

**The Fibromyomas** — also known as fibroid or fibrous tumours, myomas, leiomas, and hysteromas — are by far the most common of uterine new growths. They are stated by Bayle to occur in 20 per cent of all women over thirty-five years of age; while in women of fifty, Klob (37) estimates their occurrence at 40 per cent. Fortunately these statistics were compiled from an exhaustive and detailed examination of uteri after death, in the majority of which the growths were so small as to give rise to no inconvenience or any indication of their presence during life.

It is, therefore, of much more practical interest to make an approximate estimate of the percentage of women who suffer from pelvic symptoms due to these growths. For this purpose I have consulted the case-books of the Edinburgh Royal Infirmary, which show that of 2230 gynæcological cases, in only 176 (8 per cent) was fibromyoma the assigned cause. The figures thus obtained must necessarily be considerably within the actual proportion, as only patients suffering from urgent symptoms are treated as in-patients; while a large number of cases of fibroids are attended with minor symptoms. Further, as is well known, these tumours are more commonly met with in the more affluent classes which do not attend at hospitals. Yet when we compare the rarity of fibromyoma in gynæcological practice with the statistics of Klob and Bayle, based upon their presence in women generally, it must be assumed that the proportion of fibroids, which give rise to any symptoms whatever, is exceedingly small.

Fibromyomatous tumours are associated with the period of sexual activity. Their growth is practically confined to the years between puberty and the menopause, and it is doubtful if they ever originate before or after this period; indeed, if uncomplicated by secondary changes, they cease to grow after the climacteric. In Winckel's tables two cases are quoted as occurring in women over seventy years of age; and many cases are recorded in women over sixty. It is probable, however, that these were due to secondary changes occurring in pre-existing and unnoticed tumours, changes which are by no means an infrequent result of chronic œdema [see Fibrocystic Growths, p. 586]. A curious and interesting case is cited by Sutton, in which a tumour, supposed to be a fibroid, was present for ten years in the uterus of a childless widow, twice married, who had never menstruated, or shown any physiological evidence of ovulation.

The earliest example cited is in a girl of ten years of age (26), but unfortunately no account is given of the microscopic structure of the growth or of menstruation.

Opinion is divided as regards the influence of the sexual functions upon the development and growth of fibromyoma; but, strangely enough, this difference of opinion lies almost entirely between the pathologists on the one hand, and the gynæcologists on the other. The former maintain that these growths largely predominate in the unmarried, and Cohnheim (11) even asserts that sterility leads to their formation. Unfortunately, however, no statistics have been produced in support of this assertion. The majority of gynæcologists entertain an entirely opposite opinion; and most trustworthy investigators — such as Schroeder, Winkel, Gusserow, and others — have adduced overwhelming evidence on this side of the argument. Thus Schroeder found 614 married women in 792 cases; and Winkel and Gusserow consider the proportion of the married to the single to be as two to one.

It seems difficult at first to reconcile such conflicting statements; but on consideration of the very different sources of information — namely, post-mortem examinations and clinical experience — the inference appears that the great majority of tumours originate independently of sexual irritation, at least so far as intercourse is concerned; but that their subsequent growth is so favoured by its indulgence that symptoms and signs of the presence of the tumour more frequently arise.

The influence of fibroids upon child-bearing has at all times been a fruitful source of discussion, sterility being regarded by some observers as an actual cause of their development (Emmet). Others look upon sterility as a consequence. In support of the latter opinion almost incontrovertible evidence has been brought forward by West, Seanzoni, McClintock, Winkel, Schroeder, and many others, whose combined statistics show 621 cases of absolute sterility in 2035 cases of fibroids; that is to say, about 30 per cent were childless. When this is compared with the average sterility in women generally (10 per cent) (17), one is compelled to admit that they exercise a marked preventive influence on conception. That the sterility is due to the tumours, and not the tumour to the sterility, is strikingly supported by the important statistics of relative sterility as quoted by Winkel and Susserot (61). These afford convincing proof of the undoubted preventive effect of fibromyomata upon child-bearing. Their combined cases show that 99 fruitful women with fibroids bore only 276 children, an average of 2·8; the normal average of children to each mother in the same locality being 4·5.

West found that of thirty-six fruitful women with fibroids, the average number of children to each mother was scarcely two; twenty of the thirty-six mothers had but one child each, a most striking contrast to the statistics of Ansell, which show that normally only one in thirteen mothers have but one child.

The statistics of the effect of sexual excitement and child-bearing on the development and growth of fibroids seem to lead to the following conclusions:—

(1) That fibromyoma originates in the majority of instances independently of marriage and pregnancy.

(2) That sexual excitement in marriage favours their growth.

(3) That they tend to prevent child-bearing.

(4) That pregnancy seems to promote their growth to a great extent, so that future conception is in many cases prevented, and signs and symptoms of their presence are manifested. It will be shown, in reviewing in detail the subject of the effect of fibroids on pregnancy, that sterility is further promoted by the preventive effect of these tumours on the growth of the ovum.

*Pathological Anatomy.* — Fibromyomas may be found either in the body or in the cervix uteri; in the former site, however, they greatly predominate, 4 per cent only occur in the cervix. They are said to occur more frequently in the posterior than in the anterior wall, although from experience I cannot corroborate this statement.

Their origin has been and is still a source of much speculation. Some attribute them to the organisation of blood accidentally extravasated. Others state that they have found bacterial colonisation as the nucleus of the growth, a statement effectually disproved by Marey. Klebs attributes them to a proliferation of the connective and muscular tissues of blood-vessels, a theory which is supported by the general deposition of the muscular bundles parallel to the vessels in the tumour. The actual histogenesis has yet to be proved.

In size these growths vary from less than a pea upwards, and have been recorded as reaching the enormous weight of 140 lbs. (32).

They are most frequently multiple, and in but very few instances of apparently solitary tumours will a minute examination fail to detect other small nodules in the uterine wall. In some cases as many as fifty independent tumours may be found growing in the same uterus. A marked exception to the general rule of multiplicity is to be found in the case of the so-called œdematous fibroid, which in the large majority of instances is solitary.

Formed from the same elements as the uterine wall, the gross characters of fibromyoma vary considerably according to the relative excess of muscular or fibrous tissue in their structure; usually these growths are of a firmer consistence than the uterine wall from which they spring. In some cases, when composed largely of muscular tissue, they are soft, and give the impression of a simple hyperplasia of the uterine tissues. On section the soft varieties have a reddish pink appearance, and to the naked eye are more uniform in structure than the commoner hard variety. The latter on section appear pinky white, with wavy, glistening, whitish bands coursing in every direction, but with a decided tendency to form whorls round individual centres, an appearance which gives rise to the not inapt comparison to "a ball of wool." This characteristic appearance is due to the mode of growth of the tumour, the muscular tissue closely following and running parallel to the blood-vessels. Thus they closely simulate development from a number of distinct centres; but their origin from a single focus is proved by other facts, such as the extreme rarity of more than one nodule within the



same capsule, and the smooth, spherical form of all nodules free from irregular pressure. The cut surface of fresh sections is uneven, the elasticity of the fibrous tissue causing the softer muscular bundles to bulge externally.

The growth is usually enveloped in a false capsule derived from the uterine tissues, which have undergone marked compression changes from the ever increasing and constant circumferential pressure caused by the developing tumour.

As the capsule is formed by the surrounding tissues, it varies in thickness according to the original site of development of the tumour. Thus when the growth originates in the middle layer of the uterine wall, the surrounding capsule will be thick and well formed; but, if the tumour develop in the external or internal layers of the uterine muscle, the intervening muscular layers between it and the superimpose peritoneum, or mucosa, must necessarily be but scanty, and the capsule correspondingly thin; indeed, in some cases the muscular capsule is entirely absent, the tumour being covered by the peritoneum or mucosa alone.

Between the tumour and the so-called capsule there is a layer of loose connective tissue in which the growth is embedded, that in some cases allows of its ready enucleation. In other instances, however, there are many strong muscular and fibrous bands passing between the growth proper and the capsular wall, which prevent a ready enucleation: in some of the softer tumours these intervening bands are so numerous as to obscure any line of demarcation between the tumour and surrounding muscle, and the whole mass thus appears to be a simple hyperplasia of the uterine wall.

In the capsule, and embedded in the loose connective tissue between it and the tumour, may be seen the numerous and large blood-vessels surrounding the tumour, from which it derives its nourishment. These do not penetrate the substance of the growth to any great depth, and thus sections of well-formed vessels are but seldom found away from the periphery.

Their vascularity is but slight in comparison to that of the uterine wall from which they spring, as is well shown in Fig. 141, taken from a preparation of an injected uterus with fibroid.

In the harder varieties blood-vessels are extremely scanty, especially towards the centre of the growth; but in the softer growths they are much more numerous. They are rarely well formed, however, and appear rather to be of the nature of sinuses. The blood-supply, therefore, is usually but scanty, and the circulation at the best slow and difficult.

Normally of a smooth, round, uniform shape, the spherical contour of the original nodule may become much modified by the effects of irregular pressure, or by the development of secondary nodules in its capsule.

When examined microscopically these tumours are found to be com-

posed entirely of muscular and connective tissue elements, which vary widely in relative quantity. When young and in rapid growth the muscular tissue, as a rule, largely preponderates; but it would appear that in the majority of cases the connective fibrous tissue slowly increases at the expense of the muscular, which occasionally it almost entirely replaces. It is thus evident that no constant appearance can be assigned



FIG. 141.—Injected uterus with fibroid, showing numerous large blood sinuses in uterine wall. From specimen, Anatomical Museum, Edinburgh.

to the growth, as its structure varies within broad limits. It is usual in young and rapidly growing tumours to find the muscular elements preponderating; but although I have examined a large number of tumours, I have never yet seen an example in which (as some authors maintain) the fibrous tissue is so scant a proportion that it may be neglected, and the tumour reckoned as a pure myoma.

The distribution of the tissues is extremely various; in some cases of soft growths (Fig. 142) the connective tissue may be seen in the form of definite trabeculae passing from the capsule, and splitting the muscle bundles into distinct groups; these trabeculae at the same time carry the blood-vessels. More frequently the connective tissue and muscular bundles are indefinitely intermixed without any apparent regularity in their distribution, and according to the proportion of each so is the tumour soft or hard (Figs. 142 and 143).

The appearances presented by the muscle bundles on section vary greatly as is to be expected from their irregular disposition throughout the growth, running parallel as they do to the blood-vessels. When cut longitudinally, their elongated shape and rod-like nuclei are at once apparent and characteristic; while on direct transverse section they closely simulate groups of round cells. When obliquely severed they may have the appearance of the cells of a sarcoma.

Between the muscle bundles may be seen many spaces in the connective tissue, only here and there lined by endothelium, and forming true lymph channels. Nerves terminating in the individual muscle cells have been described by Hertz.

So far as histological examination shows, it would appear that these growths originate and develop by the proliferation of muscle fibres around the capillaries, the connective tissue at the same time being slightly increased. In this manner they may continue to grow rapidly

to a large size, and are known as soft tumours. In the majority of instances, however, the fibrous connective tissue would seem slowly but surely to increase at the expense of the muscular elements which it displaces; the tumour thus becomes harder and more fibrous, the blood-vessels are encroached upon and even obliterated, while the muscular cells themselves are only to be recognised in groups here and there. This fibrous tissue development tends to take place more in the older and central portions of the growth, which are less vascular than in the periphery of the tumour, this latter portion being more freely nourished by the vessels which everywhere pass to it from the capsule.

The rate of growth, then, must depend almost entirely on active proliferation of the muscular elements at the periphery. When the fibrous tissue predominates the increase is extremely slow, and in many cases ceases altogether; while the rapidly growing tumour is largely composed of muscle, and is thus softer and more vascular than the hard, slow-growing,

or even stationary type. On purely pathological grounds it is, therefore, impossible to divide these tumours into fibrous and myomatous varieties, as the one may insensibly pass into the other. The term fibromyoma must on these grounds be considered as the only strict scientific designation which embraces all varieties.

From a clinical aspect, however, it is well to recognise the two types of soft and hard tumours, as they vary greatly in their rate of growth, prognosis, diagnosis, and treatment.

I have said that all fibromyomas originate in the muscular layers of the uterine wall; yet the site of their development and the subsequent direction of their growth are of the utmost importance. Their clinical aspects and subsequent course differ so much with their situation, that for descriptive purposes it is necessary to distinguish them; and for this purpose they are clinically classified as Submucous, Subperitoneal, and Interstitial (Fig. 144).

**Submucous Tumours.** — These are represented by two varieties distinguished by the presence or absence of a muscular capsule. The "free" or non-capsulated variety is usually developed from the internal layers of the uterine muscle, and is thus from its origin closely

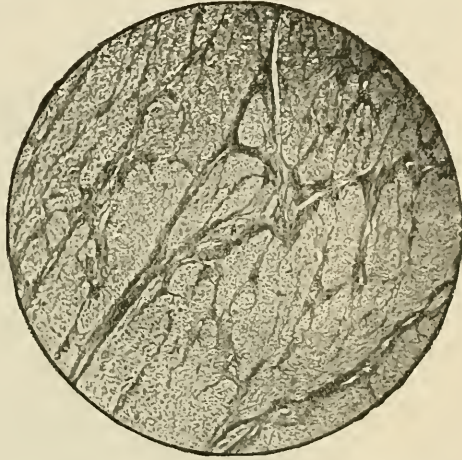

FIG. 142. — Microscopic section of soft fibromyoma, showing large muscle areas surrounded by connective tissue trabeculae carrying the blood-vessels.  $\times 40$ .



connected with the superimposed mucosa, which actually forms the false capsule from which it derives its nourishment (Fig. 145, 1 and 1A). The encapsulated variety, on the other hand, is developed in the middle layers of the uterine muscle, and its false capsule is thus formed by muscular tissue; but at the same time, as its direction of growth is towards the uterine cavity, it bulges the mucosa in front of it (Fig. 145, 2 and 2A), and on a superficial examination seems identical in appearance with the "free" variety (Fig. 145). Though thus apparently similar, their subsequent growth and attachment to the uterus are of sufficient practical importance to warrant distinction.

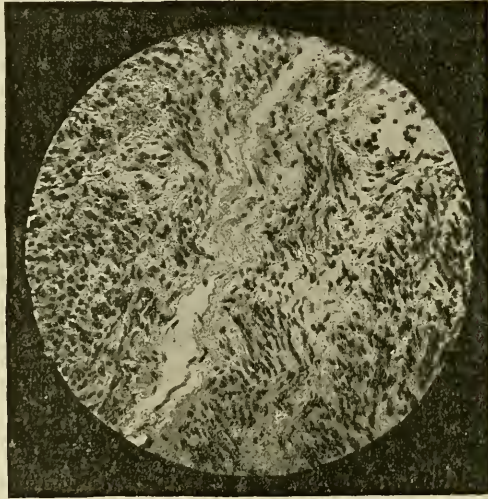

Fig. 143. — Microscopic section of common fibromyoma, showing muscular and connective tissues and blood sinus.  $\times 120$ .

In some cases a primary encapsulated tumour may become subsequently "free" by the attenuation and destruction of its muscular capsule by pressure.

The uterus, being highly intolerant of foreign bodies in its wall, and especially in its cavity, attempts by contraction to expel them. Thus both varieties of submucous tumours are prone to be driven more and more into the uterine cavity, and to become more or less stalked or pedunculated, so as to form what are known as "submucous polypi" (Fig. 146).

That this process of expulsion must be easier in the free variety is evident, as there is no superimposed uterine wall or capsule to prevent its occurrence. Should pedunculation occur, the pedicle or uterine attachment must vary considerably in the two types; in the "free" variety it will be merely represented by the attenuated mucosa, while in the encapsulated type the muscular capsule is continuous with the uterine



muscle. In some instances the latter may become so attenuated as to offer but a feeble union with the uterus; but in many cases it remains well marked and firm. It will thus be seen that the removal of the former is usually easy; of the latter it may be an affair of considerable trouble.

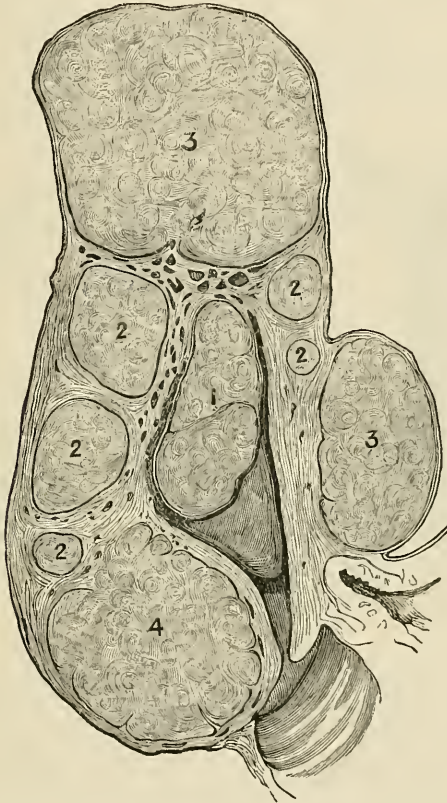

FIG. 144. — Section of fibroid uterus, from specimen in my museum, showing—1, Polypus; 2, interstitial fibroids; 3, subserous fibroids; 4, cervical fibroids.

The encapsulated tumours grow to a much larger size than the free; this is due to the preservation of the capsular circulation from which alone fibromyomas are nourished. I have, however, met with "free" polypi as large as a foetal head, the growth being nourished by large vessels situated in the highly vascular mucosa; this indeed in these cases may be considered as the capsule.

In many instances the muscular capsule resists the attempts of the uterine contractions to expel the growth; thus pedunculation is prevented, although the tumour may bulge more or less into the uterine

cavity: this form is known as the true sessile submucous fibromyoma. A submucous polypus can only be considered as the final stage of the attempt of the womb to expel tumours primarily interstitial or submucous.

Both sessile and pedunculated varieties necessarily cause enlargement of the uterine cavity, and greatly increase the vascularity of the organ.

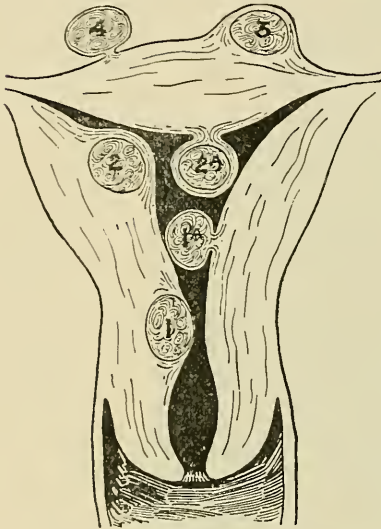

FIG. 145. — Diagram of growth of uterine fibroids. 1, 1A, Free submucous; 2, 2A, encapsulated submucous; 3, encapsulated subserous; 4, free subserous.

At the same time, by stimulating the uterine contractions for their expulsion, they lead to much general increase in the thickness of the uterine wall; so marked, indeed, is this hypertrophy in some cases, that it may closely simulate the pregnant organ in the earlier months of gestation, a similarity which has given rise to the descriptive term, "grossesse fibreuse," used by Guyon.

Primarily the entire mucous membrane may become congested, but especially that portion which actually covers the tumour. This is well shown in the injected uterus with contained polypus in the Anatomical Museum of Edinburgh University (see Fig. 146). From this site it is probable that the copious hæmorrhages proceed which are associated with this variety of tumour.

It is averred by Wyder that there is constantly an inflammatory connective tissue thickening of the entire mucosa: this process in many cases which I have carefully examined I failed to detect, although in others it was well marked. In certain cases a glandular endometritis is associated with fibromyoma, which accounts for the severe accompanying leucorrhœa frequently complained of.

Atrophy, and even ulceration of the superimposed mucosa, are occasionally met with as the result of pressure from extrusion of the tumour; and should the growth, as in the "free" variety of polypus, derive its nourishment from the vessels of the mucosa, grave secondary changes, such as sloughing and gangrene, are likely to result. From the compression exercised by the contraction of the uterus, the circulation through a polypus is frequently so far arrested that it becomes more or less infiltrated with serum. This, if acute, may result in death, sloughing, or gangrene; but if slow it does not entirely stop the nutrition of the polypus growth, though it imparts to it a soft elastic consistence which may lead to its being mistaken for a cyst (chronic œdema).

Occasionally actual cystic change is met with in these tumours (see p. 586). As the result of uterine contractions and of gravitation, all uterine polypi tend to descend towards the vagina, and their pedicles become more and more elongated and attenuated (Fig. 147). This may go so far that they may project from the vulva, though still attached to the uterus (Cullingworth).

Expulsion into the vagina may be extremely sudden, but usually it is slow. In the case of the so-called "intermittent polypus" the os uteri becomes dilated at intervals, and the growth may then be felt projecting through it. This periodic dilatation is nearly always met with during a menstrual period.

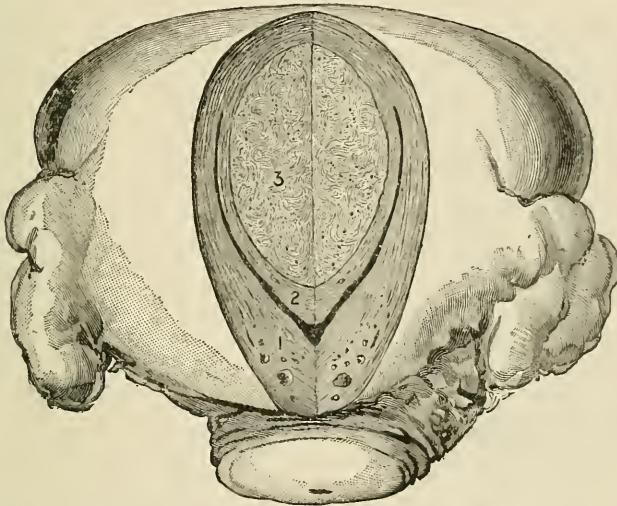

FIG. 146.—Encapsulated submucous fibroid becoming polypoidal. From specimen of injected uterus and fibroid, Anatomical Museum, Edinburgh. Half-size. 1, Uterine wall; 2, capsule; 3, tumour.

Complete separation and expulsion, though by no means unknown, are rarer events than might be supposed.

Partial inversion of the uterus not infrequently results from the too rapid expulsion of these growths; and several cases of total inversion have been recorded.

From pressure on the surrounding uterine and vaginal mucosa, ulceration and subsequent adhesions may form; and through these secondary attachments the nutrition of the tumour may be maintained, even after total separation from its original site.

During expulsion the polypus may be so firmly gripped by the cervix, that a slough of the entire intravaginal portion results. The gangrenous process may, in these cases, spread upwards through the entire tumour, when it frequently terminates fatally.

Not only, as I have said, may the uniform spherical shape, and

smooth surface of a polypus, become much altered in contour from surrounding pressure and cervical constriction, but ulceration, and consequent sloughing of the capsule may simulate closely a cancerous mass, and may be mistaken for it.

*Symptoms.*—The characteristic symptom of the submucous fibroid is uterine hæmorrhage. This occurs at a very early stage in almost every case, and thus this variety of tumour comes much more frequently under the notice of the practitioner at an early period than the subserous and interstitial varieties, which rarely give any indication of their presence till they have attained considerable dimensions.

The hæmorrhage may vary greatly in degree; but the blood loss, as a rule, closely corresponds with one of two factors, namely, the size of the growth or the extent of its pedunculation. Thus, if a small growth the size of a walnut become polypoidal, it may give rise to bleeding as severe as that from a large sessile tumour.

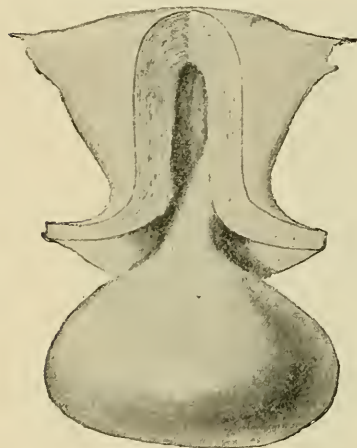

Fig. 147. — Submucous polypus. From specimen, College of Surgeons' Museum, Edinburgh. Half-size.

In a typical case of submucous fibroid the clinical picture is suggestive and characteristic; and shows a history of slowly increasing menorrhagia, with consequent anæmia and debility. The former, at first but slight and temporarily confined to the menstrual and immediate post-menstrual period, becomes more severe and continuous; intermenstrual bleeding follows in due course, and the hæmorrhage eventually becomes almost constant, and the patient is reduced to the utmost extremity.

Variations from this extreme though by no means infrequent course of events are often met with. The slowly increasing menorrhagia may rapidly or suddenly give place to copious metrorrhagia; and the character of the hæmorrhage may vary from a prolonged and constant oozing to sudden gushes of alarming magnitude. Floodings and copious intermenstrual bleedings are very commonly associated with polypi, and are probably due to lacerations of the veins in the pedicle. In some instances these must be looked upon as the only source of excessive bleeding, as the menstrual periods are frequently regular and quite normal in amount, except when broken occasionally, after many months interval, by a sudden and profuse hæmorrhage. In some cases there may be amenorrhœa for months' duration, following a severe bleeding from an intra-uterine polypus.

The source of the bleeding is twofold — from the mucosa immediately covering the tumour, and from the general lining of the uterus. Probably on most occasions they are simultaneous, but it is certain that either may act separately.



The most active primary site of the hæmorrhage is undoubtedly the mucosa covering the growth; it is always extremely vascular, but is especially so in the "free" variety, as it contains the venous sinuses from which the growth is nourished. In some cases, where from pressure the mucosa becomes atrophied, and its vascularity completely destroyed, the menorrhagia may cease. Should bleeding here continue, as it most frequently does, the source of the hæmorrhage will now be found in the general mucous lining of the uterine cavity, which is usually thickened and congested, as the result of irritation and increased uterine contraction.

That complete atrophy and absence of vascularity of the superimposed mucosa occurs, may frequently be observed in ulceration of the lower pole of a polypus without associated hæmorrhage.

The metrorrhagia is in many cases due to the rupture of veins in the superimposed vascular mucosa, a condition which accounts for the suddenness and occasional enormous amount of the blood loss. Indeed, fatal bleedings from this source have been noted by Cruveilhier and Matthews Duncan (18).

As I have already shown, rupture of the venous sinuses in the pedicle of a polypus may account for those irregular and profuse hæmorrhages which may be the only indication of its presence. This is due to actual tearing, as the expulsive action of the uterus drives the tumour outwards.

The increased hæmorrhage at the menstrual epochs, which is associated with fibromyoma, frequently remains moderate in degree throughout the entire menstrual life of the patient; there being no tendency to aggravation or to metrorrhagia. This obtains only in tumours which remain small and inactive.

Associated with the symptoms of hæmorrhage there is, in a small proportion of cases, a constant and abundant watery leucorrhœa, directly due to concurrent glandular endometritis. When present it effectually prevents the restoration of strength so necessary after a prolonged or profuse period.

Pain in this variety, as indeed in all varieties of fibromyoma, is a most variable symptom. When of considerable size the tumour usually produces a sense of weight and bearing down in the pelvis; and frequently, from the pressure of the enlarged uterus on adjacent structures, symptoms similar to those described under the subserous variety are experienced. Retention of urine is stated by Hardie to have been caused by the pressure of a small tumour on the neck of the bladder through the anterior uterine wall.

Occasionally intense and continuous pain is present with small tumours, while with others, which may distend the uterus to the size of a six months' pregnancy, little or no discomfort is felt.

Dysmenorrhœa is of fairly frequent occurrence; and is due either to obstruction of the flow of blood from the uterus by the tumour (mechanical), or to the uterine contractions which occur during menstruation, and which, under the influence of the tumour in its wall, are irregular and painful.

Pains of a labour-like nature are constantly associated with polypi, and are due to uterine contractions attempting to expel the growth. Reflex pains and neuroses of all varieties, and in every situation, may be present.

Sterility is common in this variety; indeed, conception seldom occurs. Should it do so, however, the continuance of gestation is usually interfered with (see p. 593).

The menopause is in the majority of cases much delayed.

*Diagnosis.*—The detection of submucous fibroids depends almost entirely on the history of uterine hæmorrhage, associated with physical signs of enlargement of the uterus and its cavity. The increase of the uterus as a whole is only to be made out by careful bimanual examination, when it will be found symmetrically enlarged to a greater or less extent, according to the dimensions of the neoplasm within. It may closely simulate pregnancy, but the harder consistence and the history of hæmorrhage are usually sufficient to distinguish it. Enlargement of the uterine cavity is to be diagnosed with the uterine sound, which, however, on account of the distortion of the canal by the tumour, in some cases can only be passed with difficulty. Undue force in the attempt must be carefully avoided, as laceration of the capsule may bring about serious consequences. Therefore, if much resistance be met with, a flexible gum elastic or whalebone bougie should be substituted, and will generally be found very serviceable.

The conditions most apt to be mistaken for fibroid tumour are subinvolution, or chronic metritis with endometritis; but in these cases direct derivation from a previous pregnancy, and associated chronic cervicitis, aid us in the diagnosis. Should the distinction be doubtful, nothing remains but direct digital examination of the uterine cavity, when the absence or presence of the tumour will be ascertained. The intra-uterine examination may, in many cases, be performed easily during menstruation, when the softened and gaping cervix offers but little resistance to the introduction of the finger; otherwise artificial dilatation must be used.

Polypoidal tumours, when completely intra-uterine, are to be diagnosed in a similar manner: but being usually associated with paroxysms of "labour-like" pains and metrorrhagia, a further valuable hint in their diagnosis is afforded. Occasionally the intravaginal cervix will be found much shortened; in these cases examination during a menstrual period will seldom fail to reveal a presenting tumour, the so-called "intermittent polypus."

Submucous polypi of the body of the uterus, when intravaginal, are usually easy of diagnosis by local digital examination, as the pedicle is felt to pass upwards through the cervical canal, thus distinguishing them from cervical growths. From their large size, however, and also from adhesions to the vaginal and cervical walls, a decision is sometimes impossible.

As the result of tight constriction by the cervix, or ulceration of their capsule, polypi may become gangrenous, and emit a most offensive discharge; while the tissue of the tumour itself becomes broken down and

necrosed. In this condition they are not infrequently mistaken for epithelioma; usually, however, the finger can be passed beyond the rough irregular mass, when the upper surface will be found smooth, a condition which never exists in malignant disease. Further, digital examination is seldom followed by the characteristic hæmorrhage of malignant growth.

The diagnosis of polypi from inversion of the uterus can readily be made by the introduction of the sound into the uterine cavity. In the former case it will pass farther than the normal  $2\frac{1}{2}$  inches; if the uterus be inverted the normal length of the uterine cavity must be diminished. Careful bimanual examination will also demonstrate inversion, by the absence of the uterine body and fundus, or the cup-shaped uterine depression.

Simple as these distinctions may appear, errors of diagnosis, leading to grave mishaps in operation, have been made by eminent surgeons.

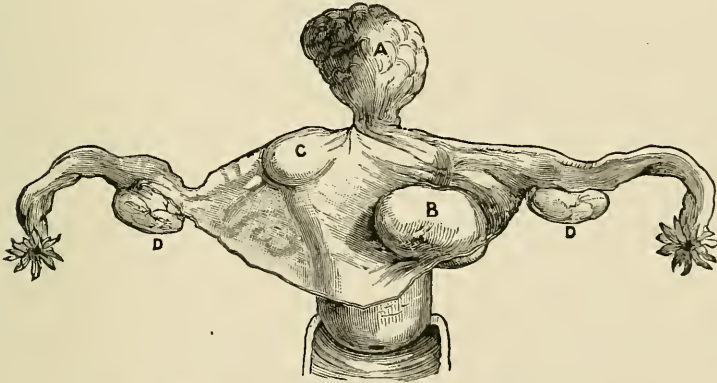

FIG. 148. — Uterus, showing subperitoneal fibroids. From specimen; half-size.

**Subperitoneal or Subserous Fibromyoma.** — In these we have a similar origin and mode of growth to the submucous, with the sole distinction that the primary fibroid nodule either originates in the external layers of the uterine muscle, and grows outwards under the peritoneum; or is developed in the middle layers, and grows, or is driven, in the same outward direction.

That there are “free” and encapsulated varieties, as in the submucous, is true; but the former rarely grow to dimensions sufficient to cause symptoms. When primarily free they seldom grow larger than a small Tangerine orange, but from attenuation of the capsule large primarily encapsulated growths may be found apparently “free.”

It is probable that the slowness of growth in the “free” subperitoneal variety, as compared with the submucous, is due to want of nutrition; as the vascularity of the peritoneal covering of the former is but slight as compared with the highly vascular mucosa.

The encapsulated variety, on the other hand, grow to enormous dimensions, there being no resistance to their growth comparable to that met with by the submucous, which has not only to distend the uterine cavity, but also to withstand the compressing force of uterine contraction.

Their attachment to the uterus naturally varies within wide limits; but usually in tumours of large size it is of considerable thickness: although cases are not uncommon where large growths have pedicles no thicker than a goose-quill. In certain instances the pedicle is so attenuated that without any apparent cause the tumour may become actually separated from the uterus.

When the pedicle is long and thin, such a degree of mobility independent of the uterus may be obtained, that in their signs these tumours may closely simulate ovarian tumours; frequently, indeed, they are so regarded till laparotomy makes clear the diagnosis. This difficulty in diagnosis is still further increased when secondary cystic degeneration is present, a variety of change frequently met with in stalked subperitoneal tumours.

The direction of growth of large subserous tumours is fortunately most frequently upwards into the abdominal cavity, although in some instances they remain pelvic; this may be due either to accidental incarceration or to burrowing among the tissues of the pelvis, with consequent splitting of the layers of the broad ligaments. This latter most serious condition is generally met with in tumours which spring from the lower part of the uterine body or supravaginal cervix.

Subperitoneal fibroids are usually associated with more or less enlargement of the uterus, though the degree of it necessarily depends on the extent of the attachment of the growth. I have, however, seen a tumour weighing over 7 lbs. attached by a narrow pedicle to a uterus more atrophied than enlarged. Thorburn describes a similar case. He removed a tumour of 12 lbs. from a small atrophied uterus.

In a similar manner the cavity of the uterus is more or less enlarged according to the degree of attachment of the growth. With a narrow pedicle this may be but fractional, and after the menopause the cavity may be found actually shortened though a large tumour be present.

Large tumours attached to the fundus may, by traction from upward growth, enormously increase the length of the cavity, and at the same time attenuate the uterus as a whole. Such a case has been described by Timms, where the uterus was so pulled out, that it was represented by a mere muscular cord, the canal being completely obliterated for a distance of two inches. Virchow avers that traction may be so extreme that complete separation of the body from the cervix may occur.

From localised peritonitis and subsequent adhesions, secondary attachments may arise; these have been known to be the sole means of nourishment of large tumours which, through laceration of the pedicle, have become separated from their original site of development.

The position of the uterus is much modified by subserous growths;



as I have said above, it may be drawn up; in other cases, however, the increased weight may cause actual prolapse. Other displacements naturally occur according to the position of the growth. If the tumour be large and pelvic, and lie posteriorly, the uterus may be tilted upwards above the symphysis pubis as in hæmatocele; while if small and growing from the fundus, retroflexion is a common consequence. In a similar manner when laterally placed, the uterus may be pushed to one or other side.

*Symptoms.* — This variety of fibromyoma, unlike the submucous, has no individual and characteristic symptom, and in many instances grows to considerable dimensions without causing the slightest inconvenience. Frequently even large tumours of this description are casually found on examination of the abdomen for symptoms in no way referable to the pelvis.

Should symptoms due to their presence be complained of, these in the majority of cases are the result of mechanical effects upon the uterus or adjacent structures. Thus when small they may cause displacements of the uterus, with their associated discomforts — many flexions and versions of the organ are due to this cause. When larger they give rise to pressure symptoms which naturally vary according to their size and position.

By far the most frequent and important symptoms are the effects of pressure on the urinary system, which may be affected in many ways. Thus derangements in micturition are extremely common, and vary with the site and size of the tumour. If seated on the anterior wall of the uterine body they tend to prevent easy distension of the bladder, and from their actual weight cause frequent micturition. When situated low on the anterior wall they early give rise to extremely painful and distressing bladder troubles, such as difficulty in urination, and even to complete retention.

When large, and incarcerated in the true pelvis, they not only tend to give rise to severe bladder discomforts such as urinary retention, dysuria, and cystitis, but from actual pressure on the ureters they may cause renal complications of the most dangerous character. Cases have been recorded where suppurative pyelitis and albuminuria have been cured after the removal of fibroids (Cabot; Porak; Skene); and doubtless many cases of overlooked kidney complications may account for fatal results after operation, as shown by Pozzi. In all cases of large fibroids special examination should be made of the urine.

Pressure on the rectum, though more uncommon, may cause obstinate constipation and severe tenesmus. Interference with the pelvic circulation, from pressure on the veins, may be associated with hæmorrhoids, varicose veins of the vulva, and occasionally, if exaggerated, with œdema of the lower extremities.

From the increased vascularity of the pelvis due to the presence of the tumour and the associated impairment of venous return by increased intra-abdominal pressure, a bluish discoloration of the vulva may frequently be noted, analogous to Jacquemier's sign of pregnancy.

Pressure on the sacral nerves is frequently associated with agonising

pains in the back and legs; while irritation of the sympathetic ganglia may cause vomiting and other reflex neuroses of indefinite characters. It will thus be evident how terrible may be the sufferings from a large intrapelvic fibroid.

Compression and irritation of the peritoneum may cause localised peritonitis, with subsequent adhesions; in some rare cases ascites has been noted. Actual sloughing and gangrene of the pelvic soft parts may occur from incarcerated tumours. Fortunately, however, the tendency of subperitoneal tumours is to grow upwards into the abdominal cavity; yet here, according to their size and position, they may give rise to pressure symptoms of more or less severity. Usually these are extremely slight, unless the tumour be of enormous dimensions. When freely movable severe sickness and other reflex phenomena may be complained of. From the increased intra-abdominal pressure causing difficulty in the abdominal circulation generally, and also from the increased blood-supply necessary for the large tumour itself, a severe strain is thrown on the heart, which is therefore hypertrophied as in pregnancy. Uterine hæmorrhage, the outstanding feature of the submucous variety, is but seldom present with subserous growths; but in some cases from associated pelvic congestion, metritis and endometritis, or the presence of other small fibroid nodules dwarfed by the large growth, bleeding may form a marked symptom.

*The diagnosis* of subperitoneal fibroids is at times extremely simple; on the other hand it may be surrounded with difficulties which make absolute certainty impossible. This is in great part accounted for by the absence of any specific symptom or sign, such as the hæmorrhage and the uterine enlargement which we find in the submucous varieties. As we have already seen the uterus may or may not be enlarged; in like manner hæmorrhage, both menorrhagic and metrorrhagic, are as frequently absent as present: indeed, the symptoms of a given case may simulate those of other pathological conditions, which indeed often present physical signs almost identical. In some cases it is only by careful bimanual palpation that the presence of any growth can be recognised; and in many a differential diagnosis, even in the hands of most competent observers, can only be provisional.

For the sake of simplifying the diagnosis it may be well to classify these growths as of three types:—

1. Those of the fundus and anterior and posterior walls of the body of the uterus, which tend to become pedunculated and grow upwards into the abdominal cavity.
2. Those of the side walls of the uterus which split the layers of the broad ligament.
3. Those of the lower part of the uterus which grow downwards into the pelvis—incarcerated tumours.

The diagnosis of large tumours of the first group is usually easy when the attachment to the uterus is well marked; for by the bimanual examination their origin from the uterus can be distinctly felt, and the two structures will be found to move simultaneously. When the pedicle of attachment is long and thin the diagnosis is much more difficult, as the uterus may be moved independently of the growth. When small it may

sometimes be difficult to decide, by simple palpation, from which wall of the uterus a tumour springs, as the tumour and the fundus may appear similar in size and consistence. In these cases, however, the passage of the sound into the uterine cavity will decide the matter at once.

A small growth on the posterior uterine wall is most easily palpated by rectal examination, with simultaneous dragging downwards of the uterus by means of a volsella. In this situation a small fibroid may be mistaken for an ovary, prolapsed and fixed in the retro-uterine pouch; by a similar method of examination the absence of tenderness on pressure, and the presence of the ovaries in another situation can be ascertained, and the exact condition determined.

When associated with surrounding inflammatory deposit, the diagnosis of small fibroids is extremely difficult and often impossible.

Occasionally small tumours of the lower part of the anterior uterine wall are extremely difficult to detect, though, nevertheless, they may give rise to most distressing urinary symptoms. Digital examination by the urethra should in these cases be practised, as in many cases by this means alone a differential diagnosis can be obtained.

Increase in the size of the uterine cavity is usually present when the uterine attachment of the tumour is well marked, although in rare cases large tumours have been found with a uterus distinctly atrophied.

When situated between the layers of the broad ligament and fixed, and at the same time displacing the uterus to one or other side of the pelvis, these tumours may be confounded with morbid tubal enlargements and cellutic deposits. Under these circumstances the history of the case, the even contour of the mass, and the comparative absence of pain on pressure, tend to remove the obscurity in diagnosis.

Tubal gestation, with a history of irregular and profuse uterine hæmorrhages, may be distinguished by the softness of the uterus and the attached swelling, the rapidity of its development, and the presence of other signs of pregnancy.

Hydro-pyo- and hæmatosalpinx, when matted by adhesions and surrounded by inflammatory exudation, may present a great resemblance. But the absence of tenderness on pressure and the enlargement of the uterine cavity will assist greatly in forming a correct diagnosis. Cellutic deposits are frequently to be distinguished only by the history of pain and fever, and their diminution under suitable treatment. From the projection of the tumour, when large, into one or other iliac fossa, where it is immovably fixed, it might at first be mistaken for a growth of the ilium. This mistake will, however, be rectified on pelvic examination which will reveal its connection with the uterus.

Large abdominal tumours are frequently associated with a marked uterine soufflé, and may thus, from their shape and median position, resemble the pregnant uterus. But the absence of amenorrhœa, slowness of growth and harder consistence, with a coexisting want of mammary and other symptoms and signs of pregnancy, should prevent any serious misapprehension.



From ovarian growths fibroids are usually to be distinguished by their harder consistence; although I have seen a unilocular parovarian cyst so tense that differentiation by this means was impossible. Other points of differential importance—such as uterine hæmorrhage, uterine souffle, increased size of uterine cavity, and the nodular outline of the tumour—may, in individual cases, assist us in arriving at a correct conclusion as to the nature of the growth; unfortunately those, one and all, are as frequently absent as present. When they have undergone secondary cystic change, the difficulty of diagnosis of fibroid from ovarian cystoma is still further increased, and in many cases laparotomy alone can decide the matter.

Solid ovarian fibroma, from its rarity, may usually be set aside; moreover, in the majority of cases, this is associated with ascites, a condition rarely met with in uterine fibroid.

Subperitoneal tumours which grow downwards into the pelvis are fortunately rare, and probably arise in the majority of cases from the supravaginal cervix with the signs of which they closely correspond. They usually retain a broad attachment to the uterus, and from their position early give rise to severe and distressing pressure symptoms.

As has already been shown, fibroids are extremely difficult to diagnose when small. When posterior they tend to lift the uterus upwards behind the pubic symphysis, and at the same time they fill up the recto-uterine and recto-vaginal space, where they may be felt as a hard fixed mass, bulging the posterior fornix and posterior vaginal wall. They may be closely simulated by incarcerated subperitoneal tumours; but these are usually more or less movable on pressure, and present a distinct sulcus between the uterus and the growth. In most cases tumours which arise low in the uterus tend to shorten the intravaginal cervix; by this property they can usually be diagnosed from the incarcerated fibroids of the upper part of the uterine body and fundus.

**Interstitial Fibromyoma.**—The primary nodule in this variety always originates in the middle layers of the uterine muscle, but has no special tendency to grow or to be driven in any one direction. Thus when of any size, it equally bulges the mucosa inwards and the peritoneum outwards; or, in other words, it is surrounded on all sides with a layer of uterine muscle of equal thickness which forms the capsule; it may be practically considered, therefore, as a simple localised thickening of the uterine wall.

These growths form a connecting link between the submucous and subperitoneal varieties, the characters of either of which they may secondarily assume, as already described. They produce the effects of both varieties on the size and position of the uterus; simulating on the one hand the submucous, by causing enlargement of the uterine cavity, and at the same time, if of large size, displacing the organ after the manner of the subperitoneal. It will thus be seen that an absolute distinction between the described varieties is impossible, as the one drifts insensibly into the other. For clinical description, however, the classification is



useful. The growth of the intramural variety is disposed to be more rapid, as its nourishment from the highly vascular capsule is less liable to be interfered with than in the other forms. From their freer circulation and more rapid growth they are usually more highly myomatous than the other varieties, and have thus a softer consistence. Hard fibrous nodules are also very commonly met with.

Their direction of growth, though frequently abdominal, is prone to be intraligamentary and pelvic. They tend, therefore, soon to give rise to pressure symptoms. They may attain enormous dimensions in a comparatively short time, and are particularly liable to secondary œdematous changes. From the multiple tendency of fibroids, examples of each variety may be simultaneously present in the same uterus; each more or less masking the characteristics of the other. It is by no means uncommon to find a submucous polypus associated with both large peritoneal and interstitial growths. It is in fact the exception for them to grow singly.

*Symptoms.* — Being the connecting link between the subperitoneal and submucous forms, the symptoms of intramural growths are more or less a combination of those of both the former. Thus on the one hand, like the submucous, they frequently give rise to hæmorrhage, dysmenorrhœa, leucorrhœa; and at the same time they are associated with the marked pressure symptoms characteristic of the subserous. It must be mentioned, however, that hæmorrhage, though a common symptom of this variety, is by no means invariably met with, even though the tumour be of large size and associated with great enlargement of the uterine cavity.

Being always surrounded by a well-marked vascular capsule, from which the nutrition of all fibromyomas is derived, they naturally tend to grow with greater rapidity and to reach enormous dimensions. When large they are always associated with a marked uterine soufflé. When extremely small their symptoms and signs are practically identical with those of metritis and endometritis, namely, hæmorrhage, with enlargement of the uterus and its cavity; and from this it is impossible to distinguish them. When of considerable proportions the regular globular increase of the uterus can be made out without difficulty. They may now be mistaken for submucous growths; but usually the hæmorrhage is not so severe, and the sound passes into the uterine cavity without difficulty. If any difficulty in diagnosis should remain, digital examination of the uterine cavity after cervical dilatation will at once decide the matter.

When small the uterus, from increased weight, is low in the pelvis; but when larger than a four months' pregnancy the uterus is pulled up, and the vagina is elongated.

From the presence of a uterine soufflé, and the frequently associated blue discoloration of the vulva, these tumours may at first sight be mistaken for pregnancy; but this error should at all times be easily avoided by having regard to the menstrual history, the rate of growth, the softness of the vagina and of the tumour, and the absence of mammary changes.

**Fibromyoma of Cervix.**—As has already been noted, cervical fibroids are much less frequent than those of the body and fundus uteri; and though in this situation they are identical in their development and mode of growth with the latter, their clinical character is so distinct as to require separate description.

As Duchemin has shown, an interstitial nodule of the uterine body may from a downward direction of growth become secondarily entirely cervical. At the same time, a tumour may by growth upwards and downwards combine the characteristics of the cervical and corporeal varieties. I had a well-marked example of this class under my own care, where a tumour distinctly felt at the level of the umbilicus was protruded at the same time through the vulva. On account of its enormous dimensions removal by morcellation was performed, as it was expected that two growths might be present, — the one a large submucous polypus, and the other interstitial or subserous. After removal, however, of the vaginal portion, the anterior cervical lip was found tightly stretched over the tumour which formed one mass, involving the posterior cervical lip and the posterior wall of the uterine body.

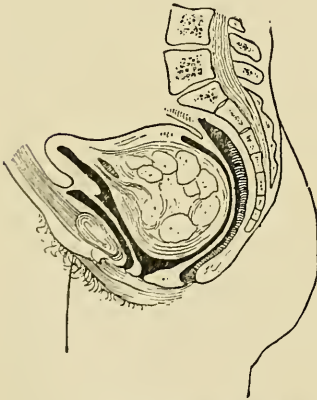

FIG. 149. — Submucous intravaginal cervical fibroid. (After Schroeder.)



FIG. 150. — Subserous cervical fibroid, tilting uterus above pubes and bulging posterior vaginal wall.

Cervical fibromyomas may be submucous, interstitial, or subserous.

The submucous varieties may be stalked or sessile, and they usually project into the vagina. They are rarely bigger than the egg of a goose, but they may be large enough to fill the whole true pelvis (Fig. 149). They tend to cause prolapsus uteri, and may closely simulate inversion of the fundus, the os uteri being frequently most difficult to find. They are rarely found to grow from the vaginal aspect of the free cervix.

When subserous they necessarily arise from the supravaginal cervix, and burrow amongst the pelvic tissues in which they become immovably

fixed; thus they may give rise to grave and distressing pressure symptoms at an early stage. They are most frequently met with posteriorly, and may burrow downwards between the vagina and rectum, so as to be felt on examination bulging the posterior vaginal wall (Fig. 150). In some cases where the tumour is larger, the uterus is tilted high above the symphysis pubis, and the cervix may be quite out of the reach of the examining finger in the vagina. They also grow laterally between the layers of the broad ligament; here they are usually sessile, though stalked examples have been described in this situation by Gemmel and Mallet. They rarely fill the utero-vesical septum, but when in this position they soon give rise to extremely distressing urinary trouble.

Interstitial cervical fibroids are extremely rare. From their fixed position they completely obliterate the vaginal fornix, and so stretch and thin the opposing cervical lip that the os uteri is frequently only to be made out with the utmost difficulty as a narrow slit. The utero-vaginal relations are thus completely altered, and on examination the vaginal roof appears to be blocked by a hard resistant mass, with the free cervix absent and no apparent os uteri. They give rise early to pressure symptoms, especially if situated in the anterior cervical lip.

When submucous they are generally associated with much leucorrhœa and feeling of pelvic weight; but, being free from the uterine cavity, they seldom give rise to the hæmorrhages which characterise polypi of the uterine body. They may, however, cause severe dysmenorrhœa from obstruction to the menstrual flow.

When small their diagnosis is self-evident; but when large and filling the vagina their attachment is often impossible to trace, and they may thus be mistaken for a fundal fibroid with inversion, as a thorough bimanual examination of the uterus and the use of the uterine sound are impossible. From their occasional broad attachment, involving the entire lip of the free cervix, they appear to rise directly from the vaginal wall, and have been mistaken for vaginal fibromyomas.

*Treatment.* — When submucous and stalked, their removal is to be performed in the manner described for polypi. When sessile their enucleation is usually an easy matter.

When interstitial or subserous, however, their removal may be by no means simple, and is only to be attempted if they give rise to serious symptoms. In this position they are unusually slow in their growth, and I have seen several cases where they seemed to undergo no change, and remained innocuous during several years.

If, however, symptoms indicate pressure, absolute removal only is of any value so far as my experience goes. Electricity and ergot are practically valueless.

Extirpation of the growth by enucleation or morcellation per vaginam, as described p. 604, can be performed with much safety.

**GROWTH AND COURSE OF FIBROMYOMA.** — The rate of growth of fibromyomata is extremely variable. In many carefully observed instances they have been known to remain for years practically stationary; while

in others large tumours have been known to develop within a few months. In general, however, their growth is comparatively slow.

Their rate of increase is naturally proportionate to the means of nourishment; and as this is entirely derived from the vessels of the capsule, it necessarily follows that thoroughly encapsulated tumours, such as the interstitial, tend to grow much more rapidly than those in which the capsule is partial or atrophied from pressure. In like manner tumours which are free from pressure develop more rapidly, which accounts for the usually large size and more rapid growth of the subserous and interstitial varieties as compared with the submucous.

Sudden and rapid enlargement may occur; but this is usually due to secondary changes such as œdema or hæmorrhage into the substance of the tumour. Temporary enlargement due to increased vascularity is manifest during menstruation and pregnancy; but it is probable that during the latter event a certain amount of increase remains, although, in many examples, involution and uterine contraction during the puerperium cause actual diminution, as the result of retrograde changes.

After the menopause active growth commonly ceases, and the tumours tend to atrophy, or at least to remain quiescent; rapid enlargement may, however, occur after this period as the result of secondary metamorphosis.

On account of the increased vascularity of the uterus due to the presence of tumours the menopause is usually delayed. Thus active growth may continue till the patient is well over fifty years of age, a point of great importance in prognosis.

The actual changes which occur in the tumour after the climacteric is one of progressive induration, due to atrophy of the muscular elements from diminished blood-supply.

**Secondary Changes.** — These, as regards the size of the tumours, may be considered as either retrogressive or progressive. The former are represented by atrophy and degeneration — fatty or calcareous; the latter by œdema, cystic formation, inflammation, and infiltration by embryonic cells.

**Atrophy.** — This, the usual event after the menopause, may occur during the sexual period; and may extend from a slight diminution in size to complete disappearance of the growth. The latter, though rare, has been noted by such close and competent observers that no doubt exists as to its actual occurrence. Thus Bantock relates an interesting example in the *British Gynæcological Journal*, and Schroeder (55) has collected and observed a large number of cases.

Slight diminution is, in the vast majority of cases, associated with evident hardening of the tumour, and is due to the excessive development of the fibrous tissue at the expense of the muscular; a process induced by diminution in the blood-supply, which may be due either to excessive pedunculation or to pressure.

The process by which actual absorption is brought about is more difficult to determine. It is probable that, in some cases at least, œdematous infiltration may be the precursor of such a result; as the softening of the



tissue generally, the associated swelling and degeneration of the individual cells, and the disappearance of their nuclei, point to a retrogressive change which may lead to complete obliteration.

The probable factor in the production of the œdema is a contraction of the muscular wall of the uterus which, from compression of the tumour, interferes with the blood return. This probability is strongly supported by the fact that, in the majority of cases recorded, the absorption occurred after pregnancy or subsequent to treatment by electricity, ergot, or removal of the ovaries, all of which means are undoubtedly associated with much uterine contraction. Thoroughly encapsulated tumours are therefore more readily influenced in this manner.

Further proof of the effect of excessive contraction of the puerperal uterus is to be found in the many cases cited where actual sloughing of the tumour has followed delivery.

*Calcification* is due to the deposit of carbonate and phosphate of lime in the fibrous tissue of tumours which have ceased to grow, and gives rise to the so-called "womb-stones." It is most frequently met with in the tumours of elderly women, in which after the menopause atrophy and induration have supervened. When present before the menopause, which is unusual, it is generally found in stalked subserous growths in which the means of nourishment are extremely slender. In elderly women, however, all varieties of fibromyoma are liable to this change.

Calcification may be present in either of two forms, peripheral or interstitial. In the former and rarer variety, a thin rough chalky deposit is found on the surface of the growth only; in the latter there is an infiltration of lime salts throughout the thickness of the growth, which may be localised in patches or invade its mass. So dense may this deposition be, that the surface of the cut sections can be polished like ivory. When peripheral calcification is complete, the centre of the tumour usually becomes necrotic from the complete arrest of its circulation.

Many examples of the interstitial type have been described, but the submucous are but rarely met with; one of the largest calcified tumours described weighed 2 lbs. 5 $\frac{3}{4}$  ozs.,<sup>1</sup> and was found in a grave, within the pelvis of an apparently elderly woman.

These calcified tumours have been known and described by Hippocrates and other ancient authors, since which time records of 51 published cases have been collected by Cruveilhier. According to some authors, the secondary change is an ossification, and the presence of true osteophytes has been recorded by Freund. In the majority of cases, however, it is mere calcification.

*Fatty degeneration* is of extreme rarity. Examples, however, are described by Turner and Hewitt (66); and a specimen, described by Sir James Paget, is to be found in St. Bartholomew's Museum (Series 33, No. 74).

*Lardaceous degeneration* is described in a unique case quoted by Stratz.

<sup>1</sup> Spec. 1799, Edinburgh Anat. Museum.

*Colloid and myxomatous changes*, on the other hand, are comparatively frequent; but as they are intimately associated with the cystic changes later to be described, consideration of them may be deferred.

*Malignant degeneration and infiltration* of fibromyoma is entirely confined to the connective tissue or sarcomatous type; it is probable, indeed, that all encapsulated sarcomas are originally fibromyomas secondarily infiltrated. Carcinoma never occurs in fibroids.

*Spontaneous sloughing*, or "necrobiosis," as it is termed by some authors, has been met with either partial or complete, and unassociated with septic influences or gangrene; it is due to a sudden and complete arrest of the circulation through the tumour, resulting from a twisted pedicle or sustained compression. When due to the former, it is associated with symptoms of pain, fever, and peritonitis, similar to those occurring with a twisted pedicle in ovarian tumours. True gangrene, however, is much more frequent. This is particularly apt to occur in submucous growths which, after the complete arrest of their circulation by uterine contraction or cervical constriction, become exposed to the influence of septic organisms entering by some ulceration or abrasion in the capsule. In this manner complete and rapid disorganisation of the tumour results; the growth may be slowly expelled. The expulsion is always associated with a vaginal discharge of an intensely fœtid character. In many instances the termination is favourable to the patient, although, of course, death may ensue from general septic infection. Artificial attempts to bring about this natural process of cure by destruction of the capsule have been made, although generally with most disastrous consequences.

*Suppuration and abscess formation* is the most frequent result of ulceration or destruction of the capsule, whether due to such interference as curettage, or the introduction of tents or other instruments for diagnostic purposes, or to natural causes. It may, however, occur rarely in subperitoneal and interstitial tumours, where no external interferences can be ascertained. Examples of such have been recorded by Lee, Lisfranc, and Jonas; and in a case of Bernays, treated by laparotomy, the enormous amount of six gallons of pus was evacuated from a subperitoneal growth.

That true suppuration can occur without direct inoculation by organisms is perhaps contrary to the weight of present pathological teaching; it is important, therefore, carefully to examine the pus in those obscure cases in order to ascertain the presence or absence of organisms.

A number of cases have been recorded by Hall and others in which suppuration of fibroids occurred during the puerperium, the result, no doubt, of septic absorption from the placental site, or from bruises caused by labour.

*Cystic Changes in Fibromyoma.*—Whether from a pathological or clinical aspect, the fibrocystic varieties of uterine tumours are most interesting. On the one hand their clinical course and physical signs are often so variable and ill-defined that they baffle detection, even at the hands of the most competent diagnostician; while their development and

structure has been and indeed is still the theme of fruitful discussion amongst pathologists.

Pathologically, they may generally be considered as due to secondary changes in previously existing fibromyomas, though at the same time it cannot be definitely asserted that they never arise *de novo*.

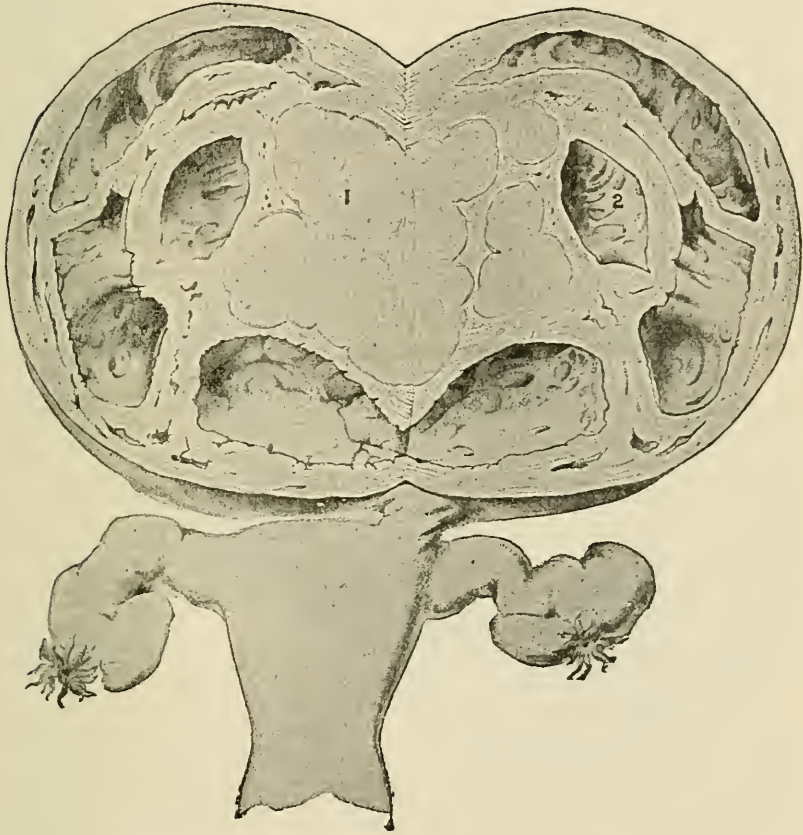

FIG. 151.—Advanced fibroeycstic degeneration of stalked subperitoneal fibroid, with partially twisted pedicle. From preparation. Half-size. Showing partial degeneration and ventricular appearance of cyst wall.

Three well-marked forms of secondary cystic development must be clearly distinguished: firstly, that due to simple degenerative changes only, which may be either fatty or the result of necrobiosis, as already described; secondly, that due to a primary infiltration with secondary degeneration, which forms by far the most common and interesting group; and, thirdly, a rare variety due to the cavernous distension of the blood-vessels in the tumour.



Though the detailed pathological appearances may have various minor differences in individual cases, the infiltrative varieties are characterised by a primary serous infiltration and associated myxomatous softening of the growth, accompanied by an œdematous swelling of the connective tissue, followed by more or less disintegration. When advanced, these changes result in the formation of spaces or false cysts filled with fluid, the walls of which are formed by the non-disintegrated portion of the tumour. At this stage the muscular bundles, being still present, prevent the formation of large cavities, and give to the cyst wall a peculiar uneven appearance, closely simulating the cardiac cavities with their columnæ carneæ. Subsequently, however, the muscle also becomes disintegrated and large spaces are formed (Fig. 151). The contained fluid in the large

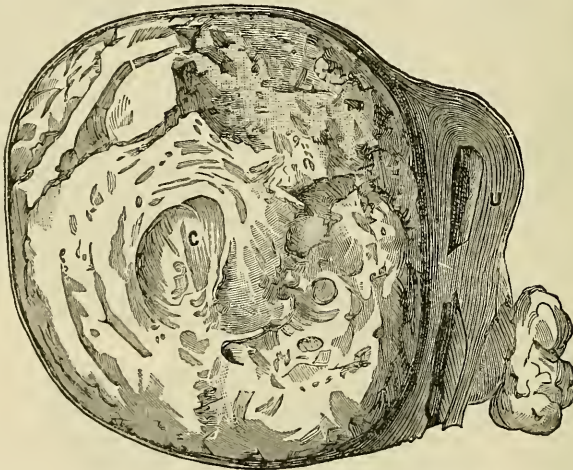

FIG. 152. — Edematous interstitial cystic fibromyoma. Drawn from preparation. One-third size. U, Uterus enlarged to 7 inches in cavity; C, cyst in tumour.

cysts varies from a pale amber to a dark porter colour, the change in colour being due to the extravasation of blood. In most instances the fluid on evacuation spontaneously coagulates; this is due to its highly albuminous nature, the exuded serum being highly charged with the products of tissue disintegration. Chemical and microscopic examination show it to contain serum-albumin and fibrin, with more or less mucin, blood, and detritus from degenerated tissue. In the early stages the fluid is almost entirely composed of serum-albumin.

The degenerative process may be confined to definite portions of the tumour, with intervening areas of higher grades of tissue; but in some instances the disintegration is so complete that a unilocular cavity is formed, bounded only by the pre-existing capsule of the tumour (Rieux).

In the early stages the cut surface may have a checkered appearance, some portions having the characters of an ordinary fibromyoma, others showing softened areas of apparently myomatous tissue, while dotted here



and there may be seen small cysts, varying in size from a pinhead to a grape. In other instances the entire growth is uniformly softened, and from its surface there exudes on section a clear yellowish fluid, which from its escape causes a marked diminution in the size of the tumour. In this stage these growths are described as œdematous fibroids. In a somewhat more advanced stage a number of cavities filled with fluid will be seen scattered throughout (Fig. 152). The entire growth may with great ease be enucleated from its surrounding capsule.

Microscopically, in the early stages, the structure is seen to be fibromuscular: the intermuscular fibrous and connective tissue is swollen and myxomatous, while the intercellular spaces are distended with fluid. Leopold and Fehling, and Rhein have described an endothelial lining forming the walls of the dilated intercellular spaces, which they recognised as lymph channels, and accordingly designated the tumour cysto-lymphangiectodes; but in cases described by Gusserow (26) and Spiegelberg no such lining was apparent. Out of five well-marked examples which I have carefully examined, in only one have I found evidence of spaces lined with endothelium, and in this one but a few small patches scattered throughout a large tumour (7 lbs.) (Fig. 153).

Examination of the cyst wall of advanced cases failed to show any true lining. In two cases of very rapidly growing interstitial tumours of this type, the microscope showed a large number of round and spindle-shaped cells situated between the bands of muscle fibres, while throughout the entire mass were isolated large round cells of an endothelial character. In all the cases examined blood extravasations were found scattered through the growth.

From the appearances presented there is but little doubt that in these tumours we have to deal with a serous infiltration or chronic œdema of pre-existing fibromyoma, which results either in a simple degeneration of a myxomatous nature, with disintegration and cyst formation, or is associated with active connective tissue cell proliferation.

The latter, from its appearance, seems to border on malignancy; and it is probable that some such tumours may actually become myxosarcomatous; but in the majority of cases they are unlikely to give rise to secondary metastases, and they do not tend to recur after removal. It is almost certain that the cause of both varieties is the same, namely,

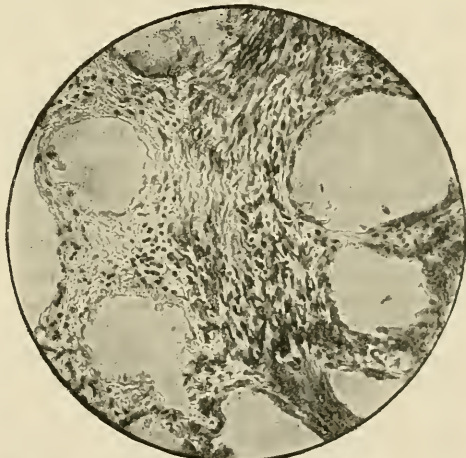

FIG. 153. — Microphotograph of œdematous fibroid, showing endothelial lined spaces.  $\times 150$ .

interference with the venous return — a condition by no means difficult to account for when one considers the usual sluggish circulation of fibroids generally: this view is corroborated by the constant appearance of areas of blood extravasation throughout the œdematous tissue. The process must then be regarded as one of chronic œdema.

That this obstruction is more complete in some cases than others, accounts for the colour presented by the growth, which varies from a light pink to a deep purple. In the latter case one seldom fails to find thrombosed vessels scattered throughout it. The immediate cause of impairment in the circulation is most frequently to be found in the capsule; thus interstitial tumours are by far the most frequently affected. The tumour may grow rapidly without sufficient dilatability of its surrounding capsule, or be compressed by the active contraction of the thick muscular surroundings. In these cases the entire tumour is affected uniformly. It may also be met with in stalked subserous tumours as the result of blockage to the circulation in the pedicle. This is beautifully demonstrated, in the preparation from which Fig. 9 was drawn, as the result of a partial twist of the pedicle; in these cases the change may be partial only, and is usually more acute, large cysts being rapidly formed and extensive hæmorrhages usually occurring. In submucous polypoid œdema is of course extremely common, but their expulsion is usually completed before large cysts are developed; or, from subsequent complete arrest of the circulation, sloughing and gangrene occur.

From a clinical aspect fibrocystic tumours are extremely interesting. In the early stages they have a soft, boggy consistence which is apt to be mistaken for fluctuation. In the later stages, when large cavities are present, fluctuation may be made out; though from the thickness of their walls this is by no means definite, even when the cavities are of considerable size.

Large cysts are specially likely to occur in pedunculated subserous growths; indeed, in fifty cases collected by Heer, five only were interstitial and two submucous. Coussat describes a fibrocyst of the cervix. Cullingworth (13) describes a similar condition in which the tumour weighed over 6 lb., and developed rapidly after the menopause.

On the other hand, in interstitial tumours simple œdematous change without the formation of large cavities vastly preponderates. As I have already pointed out, this change is almost always met with in solitary tumours; although in one case I observed small secondary nodules in the uterine wall. Their growth is more rapid than that of simple fibroids, but usually slower than that of a glandular ovarian cystoma; though there are many exceptions to this rule. They may attain an enormous size, examples of 80 lbs. weight having been recorded. From the occasional rupture of large vessels in their interior also they may rapidly assume large proportions. In a case cited by Routh several such ruptures were said to be distinctly felt by the patient. Sudden and definite enlargement from hæmorrhage, common in these tumours, may be also met with in ovarian cysts.

Cystic degeneration may occur at any age, and the subsequent growth of the tumour seems to be uninfluenced by the ovaries. Thus cystic and œdematous tumours may first give indications of their presence after the climacteric; moreover, they are in no way influenced by removal of the uterine appendages: these are material points of difference when compared with simple fibromyoma.

According to their locality, like simple fibromyoma, they may or may not be associated with uterine hæmorrhage; but, as they are most frequently interstitial or subserous, this symptom is seldom prominent.

The diagnosis is at all times difficult, and particularly so in the stalked subserous form where the signs may be identical with those of a cystic ovarian tumour. The symptoms, as we have seen, are by no means characteristic. Although special attention has been directed by Routh and Tait to the general absence of uterine hæmorrhage, this, however, is doubtless due to their rarity as submucous tumour.

When interstitial, their soft consistence and rapidity of growth, the usual absence of uterine hæmorrhage, and the associated enlargement of the uterine cavity must at all times be considered suspicious; while if developed after the menopause, and causing painless enlargement of the uterus without hæmorrhage, the diagnosis is almost assured. In like manner when a large, soft, regular uterine growth is found developing in a patient under thirty years of age, with or without hæmorrhage, the presence of a so-called "œdematous fibroid" is strongly probable.

Aspiration has been recommended in order to ascertain the special characteristics of the fluid as regards coagulability, and so forth. Such a procedure, however, cannot be too severely condemned: firstly, in the early stages no fluid can be withdrawn; secondly, so extremely feeble is their vitality that a fatal issue may be caused from resulting gangrene of the tumour; and lastly, as removal is the only treatment, whether for this condition or for any tumour with which it can be mistaken, exploratory tapping must at best be unnecessary. It may further be stated that spontaneous coagulability is by no means a specific character although it occurs in the majority of cases. A uterine soufflé is evident in all cases of the interstitial kind; but in the one case of stalked subserous fibrocystic I have seen it was entirely absent, and thus could not be distinguished from an ovariau cystoma.

Another variety of cystic degeneration, the "cavernous angioma," though pathologically well known, is extremely rare in practice. It is characterised by the abnormal development and dilatation of the blood-vessels of the growth, a change which may involve the whole tumour, or be localised in patches. Virchow (69) first drew attention to its occurrence and named the condition "Myoma telangiectodes." On section the tumour appears as a spongy mass containing a large number of cavities, which vary in size from that of a pinhead to a pea, and contain soft reddish thrombi. Subsequently, from rupture of these small cysts, with resulting coalescence, larger cavities are formed with irregular walls which closely resemble the interior of the cardiac ventricles.



Microscopically the characteristic feature is the innumerable cavities filled with blood, and lined by endothelium; these are separated from each other by intervening fibrous and muscular tissue, in which run many capillaries. Examples have been recorded by Cruveilhier, Lee, Weber, Leopold and others. In many instances they are clinically to be recognised by their increase at the menstrual periods, and their subsequent diminution.

Two examples of primary origin of these tumours in the uterus have been recorded by Klob (35) and Boldt.

Though but few angiomatous tumours have been met with and described, it is probable that this kind of secondary change may form the origin of a considerable number of fibrocystic myomas; as it is well-known that angiomatous growths are particularly liable to undergo a secondary cystic transformation. Further, the appearances presented by cystic angioma in other situations closely simulate those met with in a number of fibrocystic growths of the uterus.

This variety of cystic change may also be associated with an apparently sarcomatous infiltration of the growth proper, an example of which is described by Aslanian.

A close connection exists between this variety of tumour and the ordinary infiltrative type of cystic degeneration; for though in the early stages they may appear widely dissimilar, in the later stages of large cyst formation and degeneration their appearances must be almost identical; moreover, actual cases of combined lymphangiectoid and telangiectoid growths have been described by Müller.

It will thus be obvious how intricate is the pathology of fibrocystic uterine tumours, and how tumours, which in their origin appear widely different, may subsequently assume identical features. It is probable that their rarity to a great extent accounts for the indefiniteness of our knowledge of their development.

**Pregnancy and Fibromyoma.** — As already stated, there can be little doubt that uterine fibroids as a class tend materially to prevent pregnancy, and are a direct cause of sterility both relative and absolute; equally certain is it that their position in the uterine wall prevents this function to a greater or less extent as the tumour approaches the uterine mucosa. For this reason the submucous type is most closely identified with sterility; as then the extreme vascularity of the mucosa forms an unfavourable seat of implantation for the impregnated ovum, and one from which it tends to become separated by hæmorrhage. Sterility is less likely to occur with small subserous and interstitial tumours, though distinctly to be traced in some cases; in many cases it is due to the habitual occurrence of abortion, which is probably induced in part by the difficulty of uterine dilatation, in part by the tendency to hæmorrhage from increased vascularity.

In a case of large interstitial fibroid of the anterior uterine wall, which came under my own observation, the dilatation of the uterus was so interfered with, that the cavity was distended in the form of an



hour-glass; the placenta was situated in the upper compartment, and the fœtus grew (till the 18th week) in the lower. After abortion it was found impossible to remove the placenta, as the communication between the two cavities was not large enough to admit the finger; death occurred from septicæmia. The uterus and tumour weighed 9 lbs. A similar case is described by Lusk.

Should gestation proceed to full term, parturition may or may not be interfered with. The effect naturally varies with the position of the growth: when low in the uterus, or subserous and incarcerated in the pelvis, it may form an insuperable barrier to the birth of the child; when higher in the uterine wall they frequently cause uterine atony and irregular contractions, with their accompaniments of delay and hæmorrhage. Submucous pedunculated tumours frequently present in front of the child.

From the unequal dilatation of the uterine cavity malpresentations of the fœtus are common. Lefour found that of 100 pregnancies thus complicated 49 per cent were preternatural in their presentation. Winckel estimates breech presentations to be eight times more common, and transverse to be increased thirty-five-fold. Moreover there is a decided tendency to prolapse of the cord; and undoubtedly placenta prævia is more frequently met with.

Although, frequently, pregnancy and parturition are in no way affected by the presence of fibroids, it must be acknowledged that their association increases the risks both to mother and child in proportion to the size and position of the growth. Susserot, in 147 cases of pregnancy, shows a mortality of 55 per cent, while Pozzi asserts that in interstitial fibroids of large size the mortality is as high as 53 per cent. Although such statistics by no means represent the general mortality from pregnancy associated with fibroids, they are of value in demonstrating the possible gravity of their presence.

Of great interest also is the effect of pregnancy on the fibroids themselves. With its occurrence the tumour in most instances rapidly increases in size, the enlargement being due to hypertrophy of the individual muscular fibres of the tumour, and to a serous infiltration of the intercellular tissue, from increased vascularity. The consistence of the growth is thus much changed, and from its softness its true nature may be mistaken.

After parturition, an involution of the muscular elements of the tumour occurs simultaneously with that of the uterus itself; and this may be so marked that positive diminution or even total disappearance of the tumour may occur. This happy result is probably attained by firm uterine contraction impairing the blood-supply to the growth, and causing a degeneration of the muscle fibres analogous to that which occurs in normal puerperal involution.

Such a favourable termination is unfortunately by no means the rule; indeed, from my own observations, a permanent enlargement of the tumour is the more common consequence. In some cases this is more

evident than in others, and is due to the extrusion of the growth from the uterine wall, by contraction of the organ; but in many instances I have carefully noted a permanent increase after pregnancy, a result which probably accounts for the frequency of subsequent sterility (see p. 563). Puerperal uterine contractions often cause expulsion of submucous growths; this I have seen twice within two months of the confinement, the expulsion in each case being associated with alarming hæmorrhage. Submucous tumours are also liable, from the contraction of the uterus cutting off their blood-supply, to become gangrenous, and hence to be a source of septic infection. This result may also occur in subserous tumours. From the serous infiltration present during pregnancy the tumour may continue to grow rapidly after delivery, from increased connective tissue proliferation and other secondary changes.

True suppuration may be met with in subserous tumours as a result of parturition; this has been shown by Speigelberg to be due to the passage of organisms from the uterus through the lymph spaces. These tumours may also slough from bruising during labour, and may thus give rise to fatal peritonitis.

Gangrene and sloughing of a submucous polypus is described by Charrier to have occurred during pregnancy; the patient recovered, though birth of the fœtus took place before the removal of the septic mass.

Submucous polypi have frequently been described as presenting in front of the fœtus during labour, and in several instances have been mistaken for the fœtal head and delivered by forceps (21).

*The diagnosis of pregnancy with fibromyoma* is usually simple, though at times great difficulty may be experienced.

The presence of amenorrhœa, coincidently with an excessive enlargement of the uterus and attached tumour, is at all times suspicious and almost characteristic. Occasionally, however, menstruation may continue for some months in spite of gestation, and here by palpation alone can the true condition be ascertained.

Large interstitial tumours when associated with pregnancy may, from the regular contour of the rapidly enlarging tumour, closely simulate a hydatidiform degeneration of the chorion (9) or a rapidly growing cystic myxo-sarcoma.

In like manner an intraligamentary growth may resemble an extra-uterine gestation so closely, that absolute certainty of diagnosis is impossible. Simpson describes such a case (58). If, however, in these cases the uterus itself be definable from the intraligamentary growth, its size will be of great value in distinguishing it from an extra-uterine gestation; as in the latter the uterus, though enlarged, never corresponds with the size of a normal intra-uterine pregnancy.

From the difficulties which may be due to the tumour masking the signs of pregnancy, it is well in all cases of rapidly growing fibroids to remember the possibility of its concurrence, as by this caution many serious and even fatal errors may be avoided.

*The treatment to be adopted where pregnancy is complicated by fibromyoma* must vary according to the existing conditions in each individual case. Unless urgent symptoms demand active measures interference is uncalled for.

When the growths are small, pregnancy is but seldom affected by their presence; and even large tumours may but slightly interfere with its normal completion. The methods by which nature may overcome difficulties apparently insuperable is certainly surprising. Many cases are on record of primarily incarcerated growths which have grown upwards into the abdomen after gestation was far advanced; indeed, this may take place even during labour, as the result of retraction.

When from pressure or other causes interference is demanded, the position and character of the growth must necessarily define the method of treatment. When low in the uterus and remaining pelvic, it may give rise to symptoms of gravid retroversion; or, as in a case of my own, such symptoms may be induced by a large tumour of the anterior wall causing the gravid uterus itself to be retroposed and incarcerated. In these cases, even if pressure symptoms be absent which they seldom are, attempts at reposition are demanded, as the tumour must form an unsurmountable barrier to delivery.

If no symptoms of pressure be present, though incarceration exist in spite of attempts at reposition, it is well to allow pregnancy to proceed without interference, as the tumour in the later months, or even during labour, may be drawn out of the pelvis and in no way interfere with delivery. Should it still, however, remain fixed, and thus entirely block the passage of the child, laparotomy is the only resource. The choice of operation to be adopted must vary with the situation; but complete hysterectomy would certainly appear to be preferable to either simple Cæsarean section or Porro's operation. The mortality from Cæsarean section is stated by Säger to be 83·7 per cent. The induction of abortion when the tumour is placed low in the uterus is rendered difficult and dangerous by the want of dilatibility of the lower uterine segment and cervix, which may render it impossible to introduce the finger for removal of the secundines. Should the tumour be intra-vaginal, its removal can at any time be performed without inducing labour.

Large abdominal fibroids with pregnancy, which give rise to urgent symptoms, may be treated either by induction of labour or abdominal section. The former operation, on account of its minor severity, has been strongly advocated by a large number of writers, but has been equally strongly condemned by others, who base their arguments partly on the high mortality after even spontaneous abortion — which has been stated by Lefour to be about 35 per cent — and partly on the fact that the growth remains untreated.

The treatment by laparotomy at the hands of Schroeder (56) and others has been doubtless most satisfactory, but at the same time it shows the enormous fatality in all of about 48 per cent.



The details of the operation necessarily vary with the position and size of the tumour. If pedunculated, the tumour may be removed by myomectomy, and the pregnancy continue; a successful result is thus frequently obtained. If sessile or interstitial, the site or size of the growth must govern the method of operation, yet even in these cases myomectomy has been performed without interfering with the progress of gestation, as shown by Leopold (41). He further states that in thirty-one cases of myomectomy during pregnancy for pedunculated or sessile tumours seven mothers died, twenty-one were operated on between the fourth and sixth month, and seventeen carried to full time.

The Porro-Cæsarean operation, or the entire removal of the uterus, are the methods chiefly followed. A successful case of the latter has been described by Jessett. Ordinary Cæsarean section, on account of its excessive mortality already cited, should not be performed, not even in the few cases which may seem suitable for its adoption.

In general, therefore, the magnitude of these operations and their far from uniform success, would incline us to the less heroic measure of the induction of abortion, if urgent symptoms should arise from large abdominal fibroids complicating pregnancy. But each individual case must be treated on its own merits, the urgency of the symptoms in some cases absolutely demanding immediate surgical interference. When, however, symptoms are not so urgent as to require such energetic measures, personal experience has shown that abortion may be induced with most happy results, and the future treatment of the tumour can be undertaken with decidedly less risk at a subsequent period.

TREATMENT OF FIBROMYOMA may be divided into Medical, Electrical, and Surgical.

The **medical treatment** is chiefly symptomatic, although the entire disappearance of growths has been attributed in some instances to its means. Many drugs have been recommended — such as mercury, iodides, and liq. calcis chloridi — which have been supposed to exert a direct absorptive effect on the tumour, and probably not without some reason. Sodium chloride mineral waters have an undoubted effect in this direction. Since the rapid advancement of surgery in gynæcology, however, such uncertain methods have practically ceased to command attention, and treatment by drugs is now almost entirely confined to purely symptomatic uses.

As in the majority of cases hæmorrhage is the urgent symptom, and as it is one which more readily lends itself to medicinal antidotes, it is needless to say that the drugs used to control it are many. Sulphuric and gallic acids, turpentine, cannabis indica, and many others, have had their day; but there is none which has in any way approached the value of ergot of rye which, so far as present medical treatment is concerned, holds the field. Many writers strongly urge that by its use the development of the tumour is prevented, and its size actually reduced. There can be but little doubt that such a result is occasionally met with; although usually not until after many months or even years of active and regular



employment. The action of ergot appears to be twofold: firstly, by causing contractions of the uterus, it tends to expel the tumour from its wall, and at the same time retards its circulation by direct pressure; secondly, by its well-known direct contractile action on the blood-vessels, it materially interferes with the nutrition of the growth. Though ergot seems but seldom to exert a curative effect upon the growth and development of the tumour, it is of great value in reducing the large amount of hæmorrhage associated with many of them, and as a uterine hæmostatic it has had, and still occupies a high position; though the more decided results derived from the scientific use of the galvanic current are now rapidly superseding this form of treatment. As directed by Hildebrandt, who first introduced it, ergot is best employed by hypodermic injection; and for this purpose the solution recommended by Prof. A. R. Simpson is very suitable, namely, ℞ Ergotine ʒij., Chloral hyd. ʒiv., Aq. dist. ʒvj. Twelve drops of the above contain 3 grs. of ergotine, which is an ordinary dose. The chloral is merely added as a preservative. Care must be taken to inject the solution deeply into some fleshy part, such as the buttock, so as to avoid abscess formation. The injections are to be made twice weekly as a rule, but every second day during the menstrual period; in this manner its use must be continued for months if any change in the growth is to be anticipated. The patient may be taught to inject herself. The drug may be given by the mouth, or by suppository; but it seems thus to have a less decided effect.

Of late the fluid extract of *hydrastis canadensis*, in 20 to 30 minim doses, has been employed as a uterine hæmostatic in bleeding fibroids, and its use has met with much favour. From the difficulty in procuring the drug in a fresh state, however, treatment by this means has been too limited to form reliable results.

**Electrical Treatment.**—The treatment of fibromyoma by electricity, though by no means a new method, had not been undertaken in a thoroughly scientific manner until comparatively recent years. Routh in his interesting and able work (54) speaks of it in 1853 as a comparatively new method, and describes a case in which he got a most favourable result by passing daily through the tumour a current of high intensity for two hours at a sitting. This proceeding was discontinued after about fifteen applications, as the patient suffered from ulceration of the parts at the sites of the electrodes, which were placed on the back and cervix respectively.

After that time it was used only in an occasional and haphazard fashion until Apostoli in 1886 again called attention to its value, and brought the subject forward on a more exact and scientific basis; Apostoli's method evoked much interest, and was the source of endless discussion of a most animated and even bitter kind. Now, however, that these useless polemics have abated, and the treatment can be seen in an unprejudiced light, its high value becomes apparent.

Apostoli's method is fully described in the article on the "Electrical Treatment of Diseases of Women."

The action of the current thus administered is said to be twofold—local and interpolar.

Be this as it may—chemical, vaso-motor, or otherwise—there is no gainsaying the large array of successful cases cited by Apostoli, Keith, Milne Murray, and many others, where the current acted beneficially,—first as a hæmostatic, secondly, by arresting the growth of the tumour, and, thirdly, in many instances actually causing permanent diminution in the size of the tumour. With ordinary care the treatment can be carried out without risk and with little inconvenience.

As a hæmostatic it will seldom be found to fail if the tumour be smaller than a six months' pregnancy. Larger tumours, however, do not seem to be so rapidly benefited, although they are by no means beyond the scope of beneficial influence.

Pressure symptoms, as a rule, are relieved greatly and promptly, while the feeling of "well-being" evinced by the patient is frequently rapidly developed, and forms one of the most satisfactory benefits of the treatment. It has been averred that the symptoms of pressure, of hæmorrhage, etc., are merely temporarily benefited, and recur as soon as the use of the electricity ceases. That they do return in some cases is true, as in some cases removal of the appendages fails to stop menstruation; but in the great majority of instances a permanent arrest of bleeding and a diminution in the size of the tumour is the result. Out of twenty-five cases in which I arrested excessive hæmorrhage more than two years ago, in only four has it returned, and then was stopped again by similar methods (30).

The arrest in development and permanent diminution in the size of the tumour is equally striking. Apostoli computes it to occur in 95 per cent of cases. In submucous tumours the tonic uterine contractions induced by the current tend in many instances to cause them rapidly to become pedunculated, and further to expel them as polypi. This I have noticed in eight of my last fifty cases.

From its great success this method of electricity should, as a conservative method of treatment, be tried in all cases before the larger and more dangerous operations are attempted. Should it fail (as undoubtedly it sometimes does) the chances of successful operation, so far as my experience shows, are in no way diminished, though the contrary is averred by some surgical opponents of the method.

When from incarceration of the tumour in the pelvis, or from any other causes, it may be found impossible to introduce the intra-uterine electrode, it becomes necessary to puncture the tumour through the vaginal wall.

It is probable that after puncture adhesions will be set up, and thus complicate subsequent operation: this result should always be remembered, before this method of treatment is adopted, as it forms a slight foundation upon which antagonists of the electrical treatment of fibroids generally are but too eager to build their arguments.

Fortunately the cases where puncture is necessary are rare, as in the

majority of instances the cervix is freely accessible to the introduction of the sound.

**Surgical Treatment.**—This may be either symptomatic or radical, vaginal or abdominal.

The symptomatic vaginal methods of treatment are naturally directed against the two urgent conditions of pressure and hæmorrhage.

*Treatment of Pressure Symptoms.*—The feeling of down-bearing, and the accompanying vesical symptoms, so frequently complained of as due to the simple increased weight of the uterus, may be much benefited by the introduction of an accurately fitting ring pessary.

The extremely distressing pressure symptoms of fibroids located in the true pelvis may, if the growth be subserous and incarcerated, be generally removed by elevating the tumour above the brim of the pelvis, and maintaining it in this position by a simple Hodge or ring pessary. This is, of course, applicable only to freely movable growths such as pedunculated subserous tumours in the fundus of a retroverted or flexed uterus. When arising from the supravaginal cervix or lower part of the uterine body such manipulation is impossible, the tumour being absolutely fixed in the pelvis.

The elevation of the tumour is most easily performed with the patient in the Sims' or genu-pectoral position; steady upward pressure by the fingers is to be made through the vagina, or rectum, in a manner similar to that recommended for the reposition of a gravid retroflexion of the uterus. Should any difficulty be met with the patient should be anæsthetised, as thus, by the relaxation of parts, resistance is frequently diminished in a surprising manner.

*Treatment of Hæmorrhage.*—The mechanical methods for the arrest of hæmorrhage are manifold, and perhaps the most simple is intra-uterine injection or swabbing. The substances which have been used for this purpose include almost all known styptics; but that which seems to have given the most satisfactory results is undoubtedly iodine. Dr. Savage was the first to recommend this drug, and he preferred the injection of 1 or 2 drachms of the strong undiluted Edinburgh tincture. He was careful, however, to observe that, before injection, dilatation of the uterus must be obtained which, by allowing of the free egress of the injected fluid, prevents the intense pain and occasional subsequent attacks of peritonitis previously met with after this method of treatment. Swabbing the interior of the uterus with a dressed uterine sound, previously dipped in the tincture of iodine, is to be preferred to the intra-uterine injections; it is more easily performed, and is equally efficacious.

In preference to the use of the strong tincture, I have used with almost unvarying success a weak solution of the same tincture (3ij. to ʒ xvj. of water), and, with a Fritsch or Bozeman's catheter introduced to the fundus uteri, allowed the whole quantity slowly to pass through the uterus. This should be performed about the second or third day of the period, and so far experience has shown that it can be thoroughly relied upon. Previous dilatation is seldom necessary to allow of the introduction of

the catheter, as during the menstrual period marked softening of the cervix and even dilatation of the os are usually met with.

Intra-uterine douching with hot water is a most valuable method of rapidly arresting uterine hæmorrhage. The water should be used at a heat exceeding  $110^{\circ}$  F., as below this temperature it only aggravates the condition. Simple vaginal syringing with water at the same temperature frequently has an immediate hæmostatic effect, by causing strong uterine contraction; but this cannot be depended upon. This action of hot water has been shown by Dr. Murray to be due to the contractile effect upon unstriped muscle; thus the uterus itself, and the walls of the blood-vessels, are thrown into a prolonged tonic spasm without subsequent reaction.

*Plugging.* — This may be either vaginal or uterine, and is demanded when the hæmorrhage is so severe as to threaten life. Intra-uterine plugging by means of tupelo tents is the best method, as not only is direct pressure thus frequently brought to bear on the actual bleeding surface, but the resulting dilatation may assist in a marked degree in arresting subsequent bleeding; after removal of the tents, also, direct intra-uterine exploration can be made, and any subsequent operation performed which may seem advisable. Emmet recommends plugging the uterus with a tampon of cotton soaked in a solution of alum; this he introduces into the uterus in the form of a strip, an end being left hanging from the cervix for subsequent removal, should the uterus fail to expel it by induced contraction (19).

*Dilatation of the cervix*, either by bougies and tents or by free incision, has been long known in some cases to have a marked effect in stopping the hæmorrhage from fibroids; and at one time it was a very generally adopted method of treatment. It is very useful in relieving the dysmenorrhœa so often met with in submucous tumours. The hæmostatic action is ascribed by Simpson, Nélaton, and others as due to dilatation allowing the uterus to retract and contract firmly upon the contained tumour, and thus by compression of the vessels to prevent hæmorrhage.

*Incision of the capsule of the tumour*, although followed immediately by a temporary excess of bleeding, subsequently diminishes the hæmorrhage to a great extent. This action is probably due to the relief of tension in the capsule, which permits of the retraction of the lacerated sinuses from whence the bleeding arises, and at the same time mitigates the congestion which is present. Not only has incision a hæmostatic effect, but it has been recommended as a curative method, in order that, as the circulation of the tumour is impaired by the destruction of the capsule, the growth may undergo retrograde changes, and slough; as in some cases of polypus in which from pressure or other causes the nutrition is likewise interfered with. This method of treatment cannot, however, be too strongly condemned; as fatal results commonly occur, in consequence of the absorption of septic organisms from the gangrenous tumour.

*Curetage* of the uterine cavity is a procedure much practised by many gynæcologists. In cases of the small interstitial growths, which



do not change the regular shape of the uterine canal, the operation may be practised with much temporary benefit as regards the menorrhagia; but in the vast majority of cases, which are projecting submucous growths, the use of the curette is of but little value, from the impossibility of removing the entire mucosa, and specially that portion of it which actually covers the growth, and which is the most fertile source of the hæmorrhage. At the same time the operation is by no means devoid of risk; as occasionally, from severe laceration and destruction of the capsule, subsequent death and gangrene of the tumour follow. In one case I have seen fatal consequences from this method of treatment, due to septicæmia from gangrene of the tumour.

*Removal of the Uterine Appendages.* — As a curative method of treatment for the bleeding from uterine myoma, this operation was first performed by Lawson Tait in 1872; since that time increased experience has proved it to be one of the greatest advances in gynæcological surgery. About the same time Battey of Georgia performed the operation of removal of the ovaries for dysmenorrhœa; but to Tait must the credit be given of associating the operation with the cure of fibroid tumours. The actual operation also differs materially in the fact that Tait, while removing the ovaries, at the same time removes as much as possible of the Fallopian tube; by this means, he avers, the beneficial effect of the operation is much increased, through the consequent destruction of the nervous supply to the endometrium, which is chiefly centred in a large nerve trunk which enters the uterus just underneath the angle of attachment of the Fallopian tube.

The statistics of Tait are indeed striking, and those of other eminent operators are worth perusal. Thus, Tait shows that of the first 272 cases in which he had operated in this manner for uterine fibromyoma, twelve succumbed from the operation; a mortality of 4·4 per cent. He further records, that of fifty cases followed for six years after the operation, in seventeen the tumour had entirely disappeared; and in fourteen had become so diminished as to be harmless: forty-one of the fifty were in perfect health. From what has been stated, it will be seen that the operation not only has the effect of arresting the hæmorrhage and the growth of the tumour, but in the majority of cases it actually causes diminution in its size; in many instances, indeed, total atrophy and disappearance of the growth have been noted.

Cases of failure are to be accounted for in two ways: firstly, inability or neglect to remove the entire Fallopian tube with its surrounding nerves; and, secondly, the nature of the growth. From the size of the tumour, or from the direction of its growth, the layers of the broad ligament may become so split that removal of the entire appendages is impossible; the operation is then valueless, both as regards the arrest of hæmorrhage and increase in size; to this, probably, the majority of failures in arresting menorrhagia is to be credited.

It would appear that in the majority of cases the growth of œdematous tumours is not arrested.

In cases of prominent submucous tumours the hæmorrhage is frequently aggravated after the operation; but expulsion of the tumour within a few months may follow. Should hæmorrhage continue, therefore, after an apparently complete operation, the cavity of the uterus should be carefully explored again by the finger, so that this source of trouble, if present, may at once be removed.

From the low mortality and, as statistics further show, the excellent results accruing from its adoption, this operation cannot be too highly commended in a certain proportion of cases. The discrimination of suitable cases for its performance cannot be fixed by definite rules, and this must be determined by the medical attendant. On the one hand, it is not to be hastily adopted before less severe measures have been tried; and on the other, we must avoid the equally blameworthy procedure of temporising till the favourable opportunity has passed.

In general, it may be said that the operation is indicated in cases of bleeding and growing fibroids, where the electrical or other treatment has been tried without success; or as an alternative to the electrical treatment, should the patient so decide after having had the advantages and disadvantages of both fully explained.

The wholesale removal of uterine appendages for fibroids, without any previous attempts at treatment, cannot in the majority of cases be too strongly condemned, and must be considered not only unscientific, but culpable. From the ease with which the operation can be performed, its very satisfactory results, and the exaggerated credit accruing to the operator; the tendency has been rampant, and unfortunately still exists, to follow this line of treatment in all cases of fibroid; the majority of which are amenable to treatment by methods attended with less risk and with no mutilation. Removal of the appendages should never be undertaken, for small fibroids, without previous dilation and exploration of the uterine cavity, as small submucous polypi may be the sole cause of the bleeding, which is readily cured by their removal.

*Operations for Removal of the Tumour.*—(1) Removal of pedunculated fibroids. The methods by which these growths are to be removed vary with the situation and extent of the pedicle. If completely intra-uterine, all attempts at removal must, of course, be preceded by dilatation of the cervix. Should no previous dilatation of the cervix exist, this is to be obtained by means of tents or Hegar's dilators; but in the majority of cases, where the intravaginal cervix and os uteri externum alone are undilated, free bilateral incision by scissors up to the reflexion of the vaginal roof, is by far the most simple and efficacious method.

The ease with which the polypus itself can be removed varies according to the character and extent of the pedicle. Should it be composed but of a layer of mucous membrane — as met with in the "free" variety (see p. 576) — simple torsion of the growth is usually sufficient; but should the pedicle be thick and composed of uterine muscle (encapsulated variety), torsion must be aided by cutting. This may be done in the following manner. The patient is placed in the dorsal position, and the tumour

exposed by means of specula and vaginal retractors; the growth is then seized by strong-toothed forceps and slowly rotated; with blunt-pointed curved scissors the pedicle is next snipped gradually through, rotation of the tumour being continued as far as possible during the whole time of cutting—a process by which much hæmorrhage is frequently avoided.

Excessive traction on the tumour is to be avoided, as partial inversion of the uterus may occur. Indeed the inverted portion of the uterus has been mistaken for the pedicle, and accordingly snipped through. In all cases, therefore, the fundus uteri must be carefully examined bimanually, so that any depression of inversion may be recognised.

Removal of polypi by means of the *serre-nœud*, *chain ecraseur*, and galvano-caustic wire, are still favourite methods of operation, and are to be recommended as safe and efficacious; but as they have no advantages over the simple cutting method described, are infinitely more tedious, and involve a large increase in the already large armamentarium of the gynecologist, they are rapidly becoming less and less frequently practised. The hæmorrhage, after removal of polypi by torsion and incision, is usually but slight; but if troublesome is readily arrested by hot water injection, and intra-uterine plugging.

In cases of vaginal polypi, where from the large dimensions of the growth access to the pedicle is impossible, reduction in the size of the tumour must be gained by the removal of portions, piecemeal, until the pedicle is reached. In some of these cases incision of the tumour is followed by a considerable loss of blood; but this can usually be prevented by strong traction and torsion of the growth, aided if necessary by a running loop of strong cord passed round its base. After the pedicle becomes accessible, traction must be suspended and the pedicle snipped by means of simple torsion and scissors, as already described. After removal, the uterine cavity should be thoroughly washed out with an antiseptic, and lightly packed for twenty-four hours with sterilised Berlin wool impregnated with iodoform. The packing is of much value in rapidly curing the endometritis which so frequently is associated with these growths.

**Removal of Sessile Tumours.** — *Simple Incision of the Capsule.* — This method is now fortunately almost obsolete. Its advocates contend that by its adoption removal of the tumour results from two causes: first, from the arrest of nutrition of the tumour by interference with its capsular circulation; and, secondly, by the promotion of expulsion of the growth from its capsular surrounding by uterine contraction. By this means it is also averred that the natural destruction and expulsion, occasionally met with, are closely followed. Greenhalgh for this purpose incised the capsule with the thermo-cautery; Baker-Brown, after free incision of the capsule, lacerated the growth itself, and left it to slough. Other methods of hastening the destruction of the tumour after capsular incision, such as the injection of perchloride of iron, etc., have also been recommended.

It may be said at once, however, that such crude and unscientific



methods should never be permitted. They may simulate a natural process, but it is one which under all circumstances is fraught with much danger, and frequently ends fatally; while, further, it cannot but be apparent that the conditions are in the two cases essentially different. In nature's action we have to deal with a growth which is practically cut off from the circulation, lymphatic and other; while in the artificial method we are suddenly setting up suppuration in a growth freely communicating with the surrounding tissues, and from which absorption is but too ready to take place. It will thus be seen that if dangerous under natural conditions it will be greatly intensified under artificial conditions.

The other vaginal methods of surgical interference adopted for the removal of sessile tumours are:—

Simple enucleation, ligature of uterine arteries, simple morcellation of tumour, simple vaginal hysterectomy, vaginal hysterectomy by morcellation. The full details of these operations will be found in other sections of this work devoted to surgical methods.

Removal of sessile submucous growth per vaginam by *enucleation* was recommended by Velpeau, Atlee, Amussat, and others, more than fifty years ago; but, from its high mortality, it rapidly fell into disrepute. The procedure has, however, within the last few years been renewed with great enthusiasm, and, fortunately, on improved methods and with a knowledge of antiseptics, has been practised with most satisfactory results.

To Emmet is probably due the credit of the revival of the method as, by dogged perseverance throughout the last thirty years, he has by his traction method secured results which at once elevate the operation to a position worthy of adoption. Undoubtedly in his operation is to be found the rudiments of "morcellation" which has been adopted by Péan for the removal of all varieties of fibromyoma, and with whose name it is almost entirely identified.

From the simple removal of the tumour Péan has passed to the more formidable operation of *vaginal hysterectomy*, by which means he removes all tumours less than a six months' pregnancy, and this with the truly astounding statistics of but four deaths in two hundred cases (21). In these methods he has been worthily followed by Richelot and De Ott, whose combined statistics show 143 cases with one death.

With such a magnificent array of successes, one must admit that the operation is a decided advance in gynæcological surgery, and heartily congratulate the operators on their handiwork. But, unfortunately, there is no gainsaying the fact that this success has stimulated a surgical fashion in this direction which has passed far beyond the limits of discretion, and cannot be too strongly denounced.

In no country has the operation fever become more acute than in America; and when one reads the astounding assertion, that all fibroids should be operated on by complete hysterectomy as soon as discovered (1), and this published by an operator who has done twenty such operations within a year, it is surely time that a bold front should be opposed to



such merciless mutilation. Like almost every operation in surgery, the operation has its legitimate place, and when required should be performed; but cases needing such measures form but a small minority of fibromyomas, certainly not more than 10 per cent. Simple recovery from the operation may reach 97 per cent, but in many cases protracted invalidism results. Only as a last resort is it warranted; the less energetic measures of electricity and removal of the appendages, in the majority of cases, are amply sufficient.

The *abdominal surgical methods* of removing fibroids, namely, myomectomy and hysterectomy, are fully discussed in another portion of the System. They, like the vaginal methods just mentioned, admirably fill a limited function in the treatment of these tumours, which is not only justifiable but necessary. Such measures are particularly needed in cases of growing abdominal tumours larger than a six months' pregnant uterus, where the appendages cannot be removed entirely; and also in the rapidly growing œdematous cystic growths, where removal of the appendages is useless and therefore unnecessary, and for which total removal is alone of avail.

**B. Tumours of the Mucous Lining.**—The simple mucous growths of the uterus, from their tendency to become stalked and to protrude through the os externum into the vagina, are generally known as "mucous polypi"; but under this name are included new growths of widely different character. The name is also unhappy in so far as it is taken to represent the structure rather than the situation of the neoplasm. Growing, as these polypi do, from the mucosa, they are the result of a proliferation of the glandular or connective tissue elements alone or combined; and include therefore adenomas, fibro-adenomas, and fibromas.

The **simple adenoma** is usually met with in the cervix, and appears as a red, soft, smooth growth, varying in size from a pea to a walnut. On section it shows a sponge-like structure due to the dilated glands, which are separated from one another by thin trabeculæ of connective tissue. The gland cavities, visible to the naked eye, are filled with mucus; and, microscopically, they may be seen to be lined with epithelium, varying from cubical to elongated cylindrical forms. The tumour is covered by epithelium which may be either cubical or stratified squamous. The latter form I have found covering polypi which sprung from at least a quarter of an inch within the canal of the cervix, and protruded into the vagina (30). The same thing has also been demonstrated by Underhill and Ackermann. In its simplest variety, which Semon has described as a papillary outgrowth from the vaginal aspect of the cervix, this form of epithelial covering is naturally more frequently met with.

In its most simple form this variety of growth is represented by a simple mucous gland which, on closure, has become distended with mucus (Nabothian follicle); and subsequently so protruded from the surface that it has become pedunculated. By the combination of a series of such cysts, with proliferation of the glandular mucosa, the more complex sponge-like growth is formed.

Usually, with the glandular proliferation, there is a corresponding development of interglandular connective tissue: this is generally of an extremely cellular character, and wanting in the fibrous elements. The growth in this instance has a somewhat firmer consistence, and is usually rough on its surface, so that it resembles a ripe strawberry. These growths may be sessile, forming protuberances within a dilated cervix; and it is probable that in many cases they owe their origin to cystic extension of the new glands in the so-called "erosion" of the cervix, so frequently met with in cervical inflammation.

In the same manner an inward growth of the new glandular structure into the cervical tissues with subsequent distension of the glands may arise, which is well known as "follicular hypertrophy of the cervix."

Localised glandular proliferation of the mucosa in the body of the uterus, comparable to that described in the cervix, and giving rise to distinct polypoidal intra-uterine growths, has been described by Gusserow (27), Schroeder (57), Duncan (18), and others, and has been designated "adenoma polyposa." It must, however, be considered as of rare occurrence.

A more common variety of intra-uterine growth is the **fibro-adenoma**, which may be looked upon, primarily, as a localised hypertrophy of the normal mucous membrane. Usually in these cases the fibrous tissue predominates, the glands tending to increase rather in size than in number, and thus to form canals which permeate the growth in all directions; this variety of growth, as described by Underhill and others, has been called "channelled polypus." In some instances these growths are also found growing from the cervix. They may grow to a large size; in one example described by myself the growth weighed 21 ounces (37). When small and multiple the same condition has unfortunately been described, by Olshausen, under the name of "endometritis fungosa polyposa" — a name at once misleading and scientifically incorrect.

These neoplasms would appear from their structure to owe their origin to an active hypertrophy of the fibrous tissue of a portion of the mucosa. The glands situated in this area, however, do not themselves actually proliferate, but become enormously elongated from the outward growth of their surrounding fibrous stroma. The seat of active growth is seen by the microscope to be in the periphery of the tumour, immediately beneath the epithelium. There the tissue is embryonic and cellular, while towards the centre it is fibrous and well formed.

By dilatation of the glands, and obstruction to the escape of their secretion, cysts may be formed. In these instances the growth corresponds exactly with the common fibrocystic tumours of the mamma which, among many other names, have been called "fibroma intracanalulaire" and "cystosarcoma fibrosum." Like the mammary tumours, they are essentially benign; though in a certain percentage of cases they recur. The extremely embryonic and cellular character of the periphery of these growths might certainly lead one at first sight to classify them as sarcoma; but from this they materially differ in that the cells do not

maintain their embryonic character, but rapidly develop into mature connective tissue. Moreover, they are never associated with metastases, or infiltration of the surrounding lymphatics; and it would appear that when recurrence occurs, it is due not to a local malignancy but to hypertrophy of another portion of the mucosa.

The embryonic blood-vessels in the actively growing cellular periphery, being ill supported by the surrounding stroma, are readily ruptured; such is probably the origin of the violent bleedings which form so characteristic a clinical feature of these growths.

Another more uncommon variety of simple polypus found growing from the uterine mucosa is the **fibrous papilloma**. This is a purely fibrous tumour of a papillary form, covered by a single layer of epithelium. From the primary growth secondary offshoots are developed, each carrying with it an epithelial covering of cubical cells; thus the gross appearance of the tumour shows a rough, irregular surface of cauliflower-like character. From the approximation of these papillæ, the interspaces closely resemble glands permeating the substance of the growth and opening on its surface; but on microscopic examination their true structure is at once revealed. In a case described by Rindfleisch, small cavities lined with epithelium were found in the substance of the polypus, which he ascribed to the coalescence of the papillæ at their apices. The tissue of the tumour proper is entirely fibrous, with cells in all stages of development; the centre is composed of well-formed fibres, while towards the periphery (as in fibro-adenoma) the fibres are more and more embryonic: thus the centrifugal development of the neoplasm is demonstrated. These tumours are frequently described as "cauliflower papilloma"; but as this name is more commonly applied to malignant epithelioma of like appearance, it leads to confusion and should be dropped. Apart altogether from the nomenclature, they have been reckoned as closely allied to epithelioma, but microscopic examination and clinical observation at once disprove such an affinity. Isolated cases, as those quoted by Wagner, may occur in which a simple fibrous papilloma may subsequently develop into a malignant epithelioma, by proliferation of its epithelial elements. Such an event, however, can only be a coincidence. Such a transformation is far more likely to occur in the adenomatous types, where large numbers of epithelial cells are in active proliferation; it is probable that in many instances this variety of growth may be the origin of it, and more especially the papillary type described by Semon (already mentioned), which is covered by many layers of squamous cells.

From what has been shown of their structure, it will be evident that all mucous polypi result from the increased growth of one or other of the normal tissues of the mucosa, namely, from the glandular and connective tissues. They will, therefore, present an indefinite number of varieties of structure, entirely dependent upon the comparative excess of each; and they are to be classed accordingly. At the hands of some authors they receive but little attention, and even by others are dismissed as mere local inflammatory excrescences. Doubtless such a classification



may be simple and convenient, but as a scientific description it cannot be too strongly condemned. If consistently adopted, uterine fibromyoma must be looked upon as localised metritis, and ovarian fibromyoma as a kind of ovaritis. It is surely strange that the mucous growths of the uterus should be thus summarily dealt with, while similar conditions of the mamma, nose, and intestines are described as definite and independent neoplasms.

*Symptoms.* — The ever present symptoms which direct the attention of patient and physician to mucous polypi are leucorrhœa and hæmorrhage. The former is perhaps the more characteristic, and sometimes occurs in almost incredible quantities, associated with much irritation and pruritus vulvæ. Its character varies: generally it is clear, watery, and odourless; but it may be muco-purulent. There is but little tendency to that necrosis of the tissues of the tumour which gives the characteristic fœtid character to malignant papillomas. Hæmorrhage also is often profuse, and is by no means confined to the menstrual periods, metrorrhagia being particularly frequent.

The source of bleeding is not far to seek when it is remembered how feebly supported are the numerous embryonic blood-vessels in the periphery of the tumour. At the same time the menorrhagia is probably increased by the irritation set up by the tumour.

Unlike fibromyoma they may occur at all ages; and this feature forms perhaps the most interesting practical point in their consideration. Occurring, as they often do, late in life, many years after the menopause, they give rise to the alarming symptom of post-climacteric bleeding, and form the large majority of the few cases in which this symptom is not due to malignant disease. We have seen that they may occur on any portion of the uterine mucosa, but they are most frequently met with in the cervical canal. Their size is usually less than that of a walnut, and they may assume most varied shapes. In most instances they are smooth and soft, though in the papillary type the contrary is the case. As has already been shown, they have a marked tendency to recur after removal; but on this account alone they cannot be called malignant.

When palpable their diagnosis is as a rule easy, although the determination of simple papillary growth from papillary epithelioma can never be made with certainty without microscopic examination.

When completely intra-uterine their presence is frequently not suspected, and patients may be treated for long periods for leucorrhœa and uterine hæmorrhage, with slight uterine enlargement, till finally on dilatation of the cervix their presence is disclosed. Severe leucorrhœa and uterine hæmorrhage always indicate an early digital exploration of the uterine cavity.

Intra-uterine polypi, and particularly the variety called "endometritis fungosa," may, from their tendency to cause post-climacteric hæmorrhage, be difficult to distinguish from intra-uterine cancer; a decision can be made by the microscope alone, when the absence of active typical epithelial proliferation in the glands will be noted. Malignant disease of the



uterine body is commonly associated with pain, which is seldom present with mucous polypi, unless of large size.

Although in their recurrence after removal they still more closely simulate malignant disease, they never give rise to secondary metastases, nor are associated with marked cachexia.

*Treatment.* — This is generally to be summed up in the word removal. When small, pedunculated, and projecting through the cervix, this can easily be done by torsion or evulsion, with subsequent cauterisation of the site by Pacquelin's cautery. This latter procedure is useful, not only in arresting the hæmorrhage, which may be extremely severe, but also in so destroying the base that recurrence is prevented.

When large, their removal is most easily effected by scissors, as in the case of submucous polypi (see p. 602). The stump should, however, if possible, be thoroughly cauterised in all cases.

Intra-uterine polypi necessarily require primary cervical dilatation.

As these neoplasms have been known to be the forerunners of malignant disease, and also in some instances to recur locally, a chance is given to those smitten with the hysterectomy furor to remove the uterus. Unless actual signs of malignancy exist such a procedure is wholly unwarrantable.

I have more than once been called upon to remove successive growths of this kind from the same patient, and I can recall two well-marked cases. Five years ago, for the fourth time in eighteen months, I removed from a patient aged fifty-nine, still alive and healthy, a large number of intra-uterine adenomas, which had given rise to severe uterine hæmorrhage, and which from the microscope alone I knew to be of simple nature.

In the other case, a young woman of twenty-three, I removed, for the last time, seven years ago, and three times within two years, a simple adenoma of the cervix; since then she has had perfect health, has married, and borne four children. After removal of intra-uterine adenomas, cauterisation of the interior of the uterus is most thoroughly and easily performed by means of fuming nitric acid, followed immediately by thorough intra-uterine irrigation.

Another variety of uterine polypus, but not strictly a new growth, is the *uterine hæmatoma* or *fibrinous polypus*. From its almost constant relationship to the puerperium it is commonly known as a "placental polypus," and is due to the deposition of blood-clot in successive layers upon a retained portion of uterine decidua or placenta. The blood tumour, thus formed in a stalactitic manner, subsequently becomes organised, and may remain attached to the uterine wall for months. During the time of its formation there is a constant hæmorrhagic discharge, and usually at the period of its expulsion severe and copious bleeding. Though rarely non-puerperal, in one case, fully described in *Ed. Obstet. Transactions*, 1893, I met with a typical example in a non-puerperal patient, who suffered from intra-uterine fibro-adenoma; the case, so far as I can learn, is unique. The roughened surface of the tumour acts,

doubtless, like retained portions of secundines, by causing blood coagulation. The polypus weighed 8 ozs.

F. W. N. HAULTAIN.

#### REFERENCES

1. *Am. J. of Obstet.* June 1895, p. 652.—2. APOSTOLI. *Trans. French Surgical Congress*, 1889.—3. ASLANIAN. *Archiv. de Tocol. et gynæc.* Feb. 1895.—4. BAYLE. *Diction.* Paris, vol. vii. p. 73.—5. BERNAYS. *Am. J. Obstet.* 1895, p. 357.—6. BOLDT. *Am. J. Obstet.* 1888, p. 834.—7. BROWN, BAKER. *Obstet. Trans. Lond.* vol. i. p. 329.—8. CABOT. *Bost. Med. J.* June 1887.—9. CHAMPNEYS. *Practitioner*, January 1896.—10. CHARRIER. *Gazette des Hôp.* 1864.—11. COHNHEIM. *Vorles. u. Allgemeine Pathol.* p. 641.—12. COUSSAT. *Bullet. de l'Acad. Belgique*, 1862.—13. CULLINGWORTH. *Lond. Obstet.* June 1876.—14. *Ibid.* *Obstet. Trans. London*, 1896.—15. DANNION. *Electro-therapeutics*, March 1888.—16. DUCHEMIN. *Thesis sur tumeur fibroïdes de l'uterus*, 1863.—17. DUNCAN. *Sterility in Woman*, p. 12.—18. *Ibid.* *Obstet. Trans. Lond.* 1893.—19. EMMET. *Diseases of Women*, p. 572.—20. *Ibid.* *Practice of Gynæcology*.—21. FERGUSSON. *Lond. Obstet. Trans.* vol. i.—22. GARCEAU. *Am. J. of Obstet.* March 1895, p. 336.—23. GEMMEL. *Archiv de Tocologie*, vol. i. p. 700.—24. GREENHALGH. *Med. Chir. Trans.* vol. lix. p. 41.—25. GURLT, VON. *Langenbeck's Arch.* vol. xxv.—26. GUSSEROW. *Neubild. d. Uterus*, p. 203.—27. *Ibid.* *Archiv f. Gynäk.* vol. i. p. 246.—28. GUYON. *Tumeur fibreuse de l'uterus*.—29. HAULTAIN. *Ed. Obstet. Trans.* vol. xix.—30. *Ibid.* vol. xviii. p. 160.—31. HERTZ. *Virchow's Archiv*, vol. xli. p. 235.—32. HUNTER. *Am. J. Obstet.* vol. xxi. p. 62.—33. JESSET. *Brit. Gynæc. J.* 1895.—34. KEITH. *Ed. Obstet. Trans.* vol. xii.—35. KLEBS. *Handbuch d. Path. Anat.* 1876.—36. KLOB. *Wiener med. Wochenschrift*, 1863.—37. *Ibid.* *Path. Anat. der Weibliche Sex. organ*, p. 173.—38. LANGENBECK, VON. *Archiv f. Gynäk.* vol. xxv.—39. LEE. *Med. Chir. Trans. Lond.* vol. xxxiii. p. 281.—40. LEFOUR. *Les fibromes d'uterus au point de vue de Grossesse*.—41. LEOPOLD and FEHLING. *Archiv f. Gyn.* vol. vii. p. 531.—42. LISFRANC. *Cliniq. méd. de la hôpit. de la Pitie.* Paris, 1843.—43. MCCLINTOCK. *Clin. Mem. on Diseases of Women*, 1863, p. 97.—44. MAREY. *Trans. Internat. Med. Cong.* 1887, vol. ii. p. 836.—45. MATTEL. *Annal. de Gynaecol.* vol. vi.—46. MÜLLER. *Archiv f. Gynäk.* 1889, p. 249.—47. MURRAY, MILNE. *Ed. Obstet. Trans.* vol. xv.—48. OLSHAUSEN. *Arch. f. Gynäk.* vol. viii. p. 97.—49. PORAK. *Annal. Gynäk.* vol. xxvii. p. 140.—50. POZZI. *Sydenham ed.* p. 422.—51. RHEIN. *Archiv f. Gyn.* vol. ix. p. 414.—52. RINDFLEISCH. *Path. Gewebelehre*, 1869, p. 63.—53. RIEUX. *Bullet. Soc. Anat.* vol. xxiv. p. 19.—54. ROUTH. *Fibrous Tumours of Womb*, 1864, p. 26.—55. SCHROEDER. *Lehrbuch*, p. 230.—56. *Ibid.* *Zeitschr. f. Geburt. und Gynäk.*—57. *Ibid.* vol. i. p. 89.—58. SIMPSON. *Obstet. Works*, p. 155.—59. SPIEGELBERG. *Archiv f. Gyn.* vol. vi. p. 345.—60. STRATZ. *Zeitsch. f. Geburt. u. Gynäk.* vol. xvii.—61. SUSSEROT. *Inaug. Dissert.* Rostock, 1870.—62. *Ibid.* 1880.—63. TAIT. *Diseases of Women*, p. 194.—64. THORBURN. *Diseases of Women*, p. 259.—65. TINNS. *Trans. Obstet. Soc. London*, vol. ii.—66. TURNER. *Edin. Med. Jour.* 1864.—67. UNDERHILL. *Ed. Obstet. Trans.* vol. v.—68. VIRCHOW. *Archiv*, vol. iii.—69. *Ibid.* *Geschwulstlehre*, iii. p. 195.—70. WAGNER. *Gebärmutter Krebs*, p. 13.—71. WYDER. *Arch. f. Gynökol.* vol. viii.

F. W. N. H.

## HYSTERECTOMY

HYSTERECTOMY is a term which should have been restricted to the complete cutting out of the womb; unfortunately, however, it was in common use before the complete extirpation of the uterus had become a recognised operation, so we can only accept things as they are, and under this common term include a number of very dissimilar operations. Thus we have this term hysterectomy applied quite correctly to the procedure of complete extirpation of the uterus, either for cancer, sarcoma, or fibromyoma, and equally correctly, whether the operation be performed through the abdomen, through the vagina, or by a combination of those methods; we distinguish these several methods as *abdominal*, *vaginal*, or *abdomino-vaginal hysterectomy* respectively.

But the term hysterectomy has been long applied to a class of operations, in which the uterus, at any rate in the majority of cases, has been only partially removed, and in many merely cut into, the depth of the cutting in varying from the complete removal of a portion of its wall throughout its thickness to a mere incision through the peritoneal coat. These procedures would have been better classed under the name myomectomy, or hysteromyomectomy.

Since the operations for uterine tumours were established on a firm footing, and recognised in surgery, it has become the usual practice when removing fibromyomas to take away the whole upper part or body of the uterus, merely leaving the cervix, whether the operation ended as an intraperitoneal or extraperitoneal procedure: these operations have been very generally described by the term *supravaginal hysterectomy*, which distinguished them from the complete extirpations previously referred to. Now it is becoming increasingly common in the intraperitoneal operations to remove the whole organ, including the cervix; so that with so many very different operations it is impossible, except by prefix and by the addition of explanatory terms, to cover all with one name: thus we speak of vaginal hysterectomy for cancer, and so on. Before proceeding to describe these various operations, it is necessary very briefly to refer to the diseases and conditions which render them advisable or necessary; I say advisable or necessary, because there is no class of operations in which the question of expediency, as distinguished from necessity, so often arises.

*Tumours of the uterus* are dealt with in a separate article, so that of these I shall only say enough here to make my meaning clear. Fibromyoma, or fibroid growth, is by far the most common disease leading to the question of operation; then come cancer, in its varying forms, and the very much more rare sarcoma.

Then there is another very distinct class of cases in which *irreducible*

*inversion*, or *complete procidentia*, may raise the question of the propriety of hysterectomy. The operation in these cases is always vaginal.

*Certain malformations of the pelvis*, which render natural child-birth impossible; may also give rise to the question of the propriety of removing some part, or the whole, of the internal sexual organs.

*Fibromyoma uteri* is classified, according to its situation in the uterine wall, as *subperitoneal*, *mural* or *intramural*, and *submucous*. These terms sufficiently explain themselves; they each have attached to them certain definite symptoms, and these I will briefly describe.

*Subperitoneal growths* are generally multiple, often so numerous as to form a complete coating to the whole uterus, hard and glistening on section, commonly round or oval in shape, covered with a thin and usually easily separable layer of peritoneum, and having their chief blood supply from vessels coursing over and among them, rather than in them. They often attain a very great size, and this, and the irritation they set up in the peritoneum — an irritation sometimes leading to malignant disease — are the two conditions which may make it desirable to extirpate them. Often they hardly affect the size or shape of the uterine cavity at all, but sometimes they elongate, twist, or deform it, and they may then cause an increase of menstrual loss.

*Intramural growths* often appear to be solitary; one greatly exceeding in size any others which may be present. They usually contain more muscular fibre and less fibrous tissue, and are more vascular; they are also multiple, but rarely to the same extent as in the previous variety: in some cases almost the whole uterine wall is so involved in one of these growths that it appears to be an infiltration, but on careful examination of such a specimen it will be seen that the process is a pushing aside and a thinning of the true uterine wall, and that a sort of capsule separates the growth from the wall: these growths also attain a great size, and much more often than the subperitoneal growths lead to increased menstrual flow, or to irregular uterine hæmorrhage.

*Submucous growths* do not differ essentially from the subperitoneal; they are generally multiple, they commonly cause hæmorrhage, and they often greatly enlarge and distort the uterine cavity: they frequently become gradually separated from the muscular tissue of the uterine wall, except at one spot where their blood-vessels enter, and thus assume a polypoid form: in this state they are extruded from the uterine cavity, and appear in the vagina; sometimes they slough from the pressure exercised upon their bases and blood-vessels by the contracting uterus, when a very dangerous condition arises.

All three varieties may involve the cervical portion of the uterus, though obviously the subperitoneal can only do so partially, and by extension from the body; their presence in the cervix is often, however, of great surgical importance in deciding whether an operation be feasible at all; and, if so, what its exact nature shall be. All three varieties may be found in the same individual, but more often one kind predominates,



or is present alone. The subperitoneal and intramural most often attract attention by their size; and both, in their early stages, are apt to cause a good deal of pain, especially at the menstrual periods: the intramural and submucous forms most commonly first make their presence felt by the increased flow, irregular losses, and pelvic discomfords or actual pain.

*Conditions justifying Operation.* — Great and rapid increase of size, repeated and serious hæmorrhage, and severe pain were thought at one time to be the only justifications for operation. Now, however, the increasing success of the operations in competent hands, and the generally improved conditions of abdominal surgery, encourage the surgeon to advise operations of expediency when necessity can hardly be urged. Thus a patient may be in excellent health, and yet greatly object to go through life carrying a great tumour in her abdomen. When the conditions are favourable for safe removal, such a patient, in my opinion, is quite justified in seeking relief by operation; and the surgeon, if he has had sufficient experience in such cases, is quite justified in operating. I do not think that a surgeon without special experience is justified in performing these operations; the patient is nearly always well enough to go to a special operator, and the inexperienced cannot appeal to emergency as a plea for interference. In some cases in which size, hæmorrhage, or pain make an operation urgently necessary, it may be impossible to obtain special aid; then even the inexperienced surgeon may feel that it is his duty to do his best. Such cases are, however, rare; it is only the specially experienced who are qualified to decide as to the fitness of operations of expediency, and they alone should perform them.

*Fibrocysts* are especially interesting to the surgeon, as being often so difficult to differentiate from ovarian cysts, and also on account of their frequently extremely rapid growth, leading to urgent necessity for operation. Sometimes their cavities are full of blood instead of serum. Their pathology is of great interest, but I must refer my readers to the article on uterine tumours for further information concerning them.

*Myxomatous Tumours.* — One form of tumour deserves a special notice, namely, the large, soft, myxomatous fibromyoma: it often attains a size so enormous, that the woman appears to be attached to the tumour, rather than the tumour to the woman; it usually burrows deeply into one or other broad ligament, or under the pelvic or abdominal parietal peritoneum. This tumour is often spoken of as the œdematous fibromyoma. I have seen a case of this kind, in which the whole peritoneum lining the pelvis, and much of that of the lower part of the abdominal cavity, was stripped off and raised upon the surface of the tumour, so that the latter lay in immediate relation with all the important vessels and nerves supplying the lower extremities, and with the ureters. In such a case adhesions not uncommonly form between the tumour and these important structures, conditions which have to be kept in mind when discussing operative interference. It is not this particular kind of tumour only which grows into the broad ligaments, or under the parietal peritoneum; the ordinary fibromyoma not infrequently does so,

and I shall have to refer again to the increased difficulty and danger encountered in operating upon such cases.

*Sarcoma of the uterus* is very rare, and probably as a primary disease seldom appears of a size to form an abdominal tumour; it is commonly intra-uterine, and closely resembles an intramural or submucous fibromyoma becoming polypoid: from these it can only be distinguished by its softness and the rapidity of its growth, by the general condition of the patient, or by dilatation, excision of a portion of the growth, and microscopic examination. Primary uterine sarcoma is also occasionally met with as a degenerative growth in old fibromyoma; it is a degenerative change in the cellular tissue, and in such cases may form a very large abdominal tumour.

*Carcinoma* does not occur as a degenerative change in fibromyoma; it is always a primary disease.

*Adenoma and Carcinoma.* — As we have three varieties of fibromyoma, so we have practically three varieties of carcinoma; and these again have special seats and symptoms. Adenoma is often benign, but liable in some cases to recur and become malignant.

Columnar epithelioma of the glandular type attacks both the body and cervix; squamous epithelioma attacks the os, and is also found in the cervical canal, but rarely if ever reaches the cavity. The columnar variety is much commoner in the substance of the cervix, where it probably arises from the cervical glands, than in the uterine cavity. Squamous epithelioma spreads along the surface more than it penetrates; columnar, in its early stages, is often covered in by healthy tissue. I need not dwell upon malignant disease, however, as it is dealt with in a separate article, in which will be found also the description of the operations suitable for its removal, including those which give their name to my article.

In dealing with the operations for simple tumour, for inversion and procidentia, and for malformations interfering with natural labour, I shall describe them as I am in the habit of performing them, and I shall then give a brief description of such additional operative procedures as I think worthy of further trial and consideration.

**Supravaginal Hysterectomy** (Extraperitoneal). — The stump in this operation is secured either by the well-known wire *serre-nœud* of Koeberlé — I always use this myself — or by the elastic ligature; and is fastened into the lips of the abdominal wound outside the peritoneum.

*Preparation of the Patient.* — This consists in a careful regulation of the bowels by mild aperients and enemata, aided by a somewhat restricted and light diet, for a week before the operation. An hour before the operation the site of the incision, the pubes, and vulva are well washed with carbolic soap and water, and the former is covered with a thick pad or towel wet with 1 to 20 carbolic lotion, and applied under a piece of mackintosh cloth or oil silk and a bandage. Immediately before the patient comes into the operation room the nurse should pass the catheter. Some surgeons think this is not necessary, but I have seen very experi-

enced operators wound a full bladder in making the peritoneal incision, and I much prefer the bladder to be empty. I always shave the pubes myself just before I operate, and after the patient is under chloroform; it takes a few seconds only, and spares the patient a very disagreeable process. The abdomen and chest are protected by an india-rubber sheet, a hole proportionate to the expected size of the incision being cut in it, and its edges coated with a layer of carbolised adhesive plaster an inch and a half broad.

*Operation.* — When operating for fibromyoma the incision through the peritoneum must be made with a little more care than in ovariectomy, as a slight wound of the surface of the tumour may cause severe, or at any rate troublesome hæmorrhage, which it may be difficult to check in the dense fibroid mass. As soon as the tumour is well exposed, and all bleeding from the edges of the abdominal incision is stopped with pressure forceps, or fine silk ligatures, as appears more desirable, the hand is introduced and swept over the abdominal surfaces of the tumour to estimate its size, and to detect adhesions if there be any; it is then passed into the pelvis and round the base to see whether it will be necessary to remove the ovaries and tubes, and whether these can be included in the wire or elastic ligature, or must be tied off separately. I always leave one ovary if I can, as I find that, if this be done, the patients recover more quickly and completely, and suffer infinitely less at the change of life; especially do they escape the depression which is apt to follow complete removal of uterus and ovaries. If the ovaries and tubes, or an ovary and tube, have to be tied off, I apply the ligature either by transfixion through the utero-ovarian ligament or, if this be impossible, as it often is in these cases, through a thin non-vascular bit of the broad ligament pretty near the side of the uterus; then, after tying off the ovary and tube, I leave one loop of the transfixing ligatures untied to be used in case of any oozing or slipping of ligature during later steps of the operation. I pass the *serre-nœud* wire, or elastic ligature, through the puncture made in transfixing the right broad ligament, and again through the puncture on the other side if both halves of the broad ligament are tied off. If the broad ligaments are not tied off the wire merely passes round the base of the tumour, including one broad ligament and transfixing the other, so as to exclude the ovary and tube on that side. If the tumour be very large and vascular, and the broad ligament much opened up, it is desirable to apply two temporary clamps on the sides of the uterus, and to cut the broad ligament, between them and the ligatures, down to the transfixion punctures; this greatly frees the tumour, and renders the tightening up of the constricting material much easier. In many cases it is necessary, before screwing up, to peel back the peritoneum both in front and behind, first carrying a nearly horizontal incision just through the thin peritoneal covering (so as to avoid any visible vessels) from one transfixion point to the other, and then to push it down with the fingers, so that the wire or rubber is applied on the denuded surface, and all chance of drawing in the bladder

or the ureters is avoided. In the great majority of cases it is, in fact, better to push down the bladder in this way; the posterior enucleation is rarely required. After the wire or ligature is tightened up, a strong pin with a little screw cap is passed through the uterus from side to side just above the wire; sponges are packed all round, and the whole tumour and upper part of uterus are rapidly cut away, special care being taken to dry up at once any mucus or fluid which exudes when the uterine cavity is cut across. In the great majority of cases section takes place near the internal os, and only a small opening, filled with a little plug of mucus, is seen in the middle of the stump; but sometimes a large bloody cavity is opened, and then, unless great care be taken, fouling of the peritoneum may easily occur. To cleanse this cavity I always use absorbent cotton soaked in pure tincture of iodine, or in  $\frac{1}{10000}$  corrosive sublimate solution. There is usually some shrinkage of the tissues included in the wire or rubber ligature after the tumour is cut away, and, if the enclosed stump be large, it may be necessary to tighten up the screw of the *serre-nœud* several times during the concluding steps of the operation.

I have described the procedure without any mention of adhesions; if they are present, especially if they are omental, they often contain enormous vessels, and in separating them great care is required to avoid serious loss from the uterine side after they are tied and divided on their proximal side. Wells' large pressure forceps, and the square-ended ones which bear my own name, are very useful for such adhesions. Adhesions of large surfaces of intestine are exceeding difficult to deal with; there is no room to apply ligatures before separating, and no room, or not firm enough tissue, to apply pressure forceps after separation; thus both surfaces frequently ooze very freely, and much blood may be lost during the future steps of the operation: these patients can rarely spare blood; sponge pressure is the only way of dealing with these oozing surfaces. The raw intestinal surfaces often require fine silk to be passed carefully under the peritoneal and into the muscular coat, and drawn together bag-mouth fashion, to check the oozing when the tumour has been got rid of, and before closing up. If there is likely to be much oozing after the peritoneum is closed, I use a Keith's glass tube passed to the bottom of the pelvis as in ovariectomy; and I usually bring it out rather high up in the abdominal incision, so as to tie two or three sutures between it and the stump, and get room for some dry antiseptic dressing between; for the stump in most cases soon becomes septic. For the same reason I always get rid of the tube as soon as possible after the operation: I believe the presence of much fluid in the drainage tube after the first thirty-six or forty-eight hours is often a sign that the tube is irritating a sensitive peritoneum, a point which can be tested by slipping a fine rubber tube through the glass one when the latter is withdrawn, and the former is left for another twelve or twenty-four hours: if the discharge then quickly diminish the tube can be removed entirely; if it continue, sufficient drainage is provided. Septicity



of the discharge is sometimes indicated by a prolonged or increased flow from the tube, and this without the smallest perceptible odour; so that removal of the glass tube must be carefully considered whenever there is anything abnormal either in the quantity of the flow or in its duration.

For ligatures and sutures I still prefer pure Chinese silk twist well soaked in 1 to 20 carbolic solution: No. 1 for adhesions, or No. 0 for very fine intestinal work; No. 2 for sutures; No. 3 for a special strong suture in these cases above and below the stump, and No. 3 for tying the broad ligaments. I sometimes use No. 4 for temporary tying off of parts during a difficult operation, but never to leave in the peritoneum. I believe that the use of too thick silk is a fruitful source of the pelvic swellings, abscesses, and sinuses, about which I am not infrequently consulted, but which I am happy to say are unknown in my own practice. I have even heard of No. 5 being used to tie an ordinary ovarian pedicle; I do not think I ever had a skein of this size in my possession, even in my early days when I had not fully tested the wisdom of using the finest silk which would do the work required of it. After the closure of the abdomen I pare down the stump as much as possible, especially cutting away the inside fibrous and muscular tissue into a somewhat cupped shape; pack it firmly round with dry carbolic gauze; and then with great care apply a little solid perchloride of iron to the cut surface: this agent must be used very sparingly and carefully, as it causes a flow of acid serum, which is very dangerous if it trickle into the peritoneum; but I am sure it is a great safeguard if properly used. First, if the constriction of the wire relax at all through shrinkage during the first few hours after the operation, it effectually prevents any oozing from the stump; secondly, it dries and tans the stump, so that putrefaction from the central cavity spreads into it very slowly, and only after some days when the parts round about are sealed, and putrefaction is no longer so dangerous. I altogether disapprove of sewing over the peritoneal edges of the stump; it is quite useless if the perchloride of iron be used, and must in any case shut up material which is much better escaping freely into the dressings at once. I have seen half an hour wasted over this sewing up of the stump, when the operation had already been long enough to tax the patient's strength to the utmost.

*After Treatment.* — I sometimes arrange so that the screw of the serrenoud can be exposed without disturbing the rest of the dressing, and a screw up given to it every twelve or twenty-four hours; but this is only necessary with very thick stumps, and in most cases it is best to leave the dressings undisturbed for several days, and then change everything, dusting all the time with a pepper dredger full of finely powdered boracic acid. The second dressing comes about the eighth day, and then alternate sutures are removed. I generally leave the last two or three sutures a good deal longer in these cases than after ovariectomy, as the wounds are especially liable to reopen. I suppose the firm wedge of pedicle has a tendency to draw open the wound; certain it is that these incisions require

far more care during convalescence than wounds in which the abdominal cavity is completely closed. The gaping of a wound after removal of the sutures was a much more frequent occurrence in the old clamp days of ovariectomy than now; and in both cases the presence of sepsis in the lower part of the wound probably retards firm healing throughout.

The treatment of the stump varies according to its size and thickness. If the part enclosed in the wire be small, I generally screw it up at the early dressings, and then leave it alone till it sloughs off; if it be a thick pedicle I clip it well down at each dressing after screwing it up, and very often clip it down to the wire and pin at the end of two weeks and remove them: the remaining slough I leave to separate by itself, merely clipping away loose shreds. This necessary sloughing and separation of the stump are the weak points in this extraperitoneal operation. The process is attended by a certain risk of septic absorption, especially if the surgeon is too much inclined to pull the stump about at the dressings; it makes the convalescence tedious; often five or six weeks elapse before it is entirely gone, and even more before the granulating cavity is closed up; and, when cicatrisation is complete it often leaves a weak place in the scar. In spite of these obvious disadvantages I still prefer this method in the great majority of cases to any of the modifications which have been proposed; certainly in my own hands it has yielded a greater number of good recoveries than the intraperitoneal method which I shall now describe.

**Supravaginal Hysterectomy (Intraperitoneal).** — In this operation the stump is secured by ligatures and sutures, its peritoneal edges are brought together over its whole surface, and it is then dropped into the peritoneum as is the stump of the pedicle in an ordinary ovariectomy. The difference between these two stumps is not, however, sufficiently considered by those who advocate this method. Unless the needles or ligatures used by the surgeon contain septic materials, the ovarian pedicle stump contains nothing but sound uncontaminated tissues; the uterine stump, on the other hand, always contains in its centre a cavity which it is impossible to render certainly aseptic; in some cases, no doubt we can clean the uterine cavity with strong antiseptics just before the operation, but this procedure is extremely difficult or even impossible when the cavity is very irregular in form, and twists and turns about in the tumour, and we can never be sure that our applications have been so thorough as completely to clean away all possible sources of contamination: then, if any septic material be left it lies right in the centre of the stump, and in immediate contact with tissues rendered specially prone to decay by the interference with their nutrition caused by the constricting ligatures and sutures, and by the rough handling they have had during the separation of the tumour from its base. That this is a very grave objection to this particular method its statistics show; and the danger is greatly increased by the occasional occurrence of hæmorrhage into the stump which, even when not sufficient in amount to be

dangerous as hæmorrhage, adds greatly to the risk of septicæmia from the additional material it gives for infection, and from the still further interference with the nutrition of the stump tissues. Hæmorrhage to a fatal issue is also still one of the risks of any complete intraperitoneal method, though this has been greatly reduced with increase of experience in the securing of the vessels, and in the application of the constricting ligatures and sutures to the stump.

I need not recapitulate the steps in the operation, which, up to the time when the tumour is freed from adhesions, if any, and brought outside the abdomen, are exactly the same as in the one just described. If the base of the tumour be sufficiently clear of the lower segment of the uterus for the passing of a ligature round the whole base, including the ovaries and tubes — or round one ovary and tube, if the other is to be left behind — a strong piece of red rubber tube is passed round, firmly drawn up, and its crossed ends secured in a pair of large pressure forceps; then a pin, similar to that used in the other operation, is passed through the uterus and one or both broad ligaments, close to the upper side of the ligature, and, sponges being packed round the tumour, it is cut away; great care must be taken to leave a sufficiently large stump, and especially a broad margin of the peritoneal covering. One or both broad ligaments, according as one ovary or both is to be removed, are then secured by transfixion in the usual way; the inner loop of the transfixing ligature being left untied for future use if required, as described in the extraperitoneal method. The uterine arteries, which can be readily felt pulsating, are now separately secured by transfixion, care being taken to carry the needle close to the cervix, and to remember how close in this situation the ureters lie to the uterine arteries. The stump is then carefully pared down to the size and shape in which it is to be left, and a deep cup made in it by paring out its centre; the mucous membrane is cut away right down to the level of the constricting ligature: then, if it be possible, a fine probe armed with cotton wool soaked in some powerful antiseptic should be passed through the centre of the stump into the vagina; some operators use the cautery for this, but I do not think the plan a good one; it may destroy the septic material, but it leaves a layer of dead tissue, and below this a layer of damaged tissue in the stump, just when we want everything to be as healthy and as capable of quiet repair as possible.<sup>1</sup> After the cleansing is as perfect as it can be made, the edges of the mucous opening are carefully brought together by a few points of fine silk interrupted suture which are cut short; then the deeper parts of the muscular tissue are brought firmly together by another row about half an inch from the first sutures; then the constricting band is relaxed, and pressure forceps are applied to bleeding points, which, however, will be few if the broad ligaments and uterine arteries have been efficiently dealt with: after a pause, to allow anything that

<sup>1</sup> It will be seen farther on in this article, that recent observations show that in most cases the cervical canal does not contain putrefactive organisms, and this demonstration may modify our practice in this particular.



is going to bleed to show itself, all the points in the forceps are carefully secured by fine silk passed with a fine needle under the open mouth of the vessel, the pin is removed, and the peritoneal edges are brought firmly together over the surface of the stump, first by a row of interrupted sutures, and then by a fine continuous suture, so applied as to bury the first row between inverted peritoneal surfaces; the stump is then allowed to sink back into the pelvis, and the abdominal incision entirely closed, unless it be thought desirable to drain, in which case a Keith's glass tube is passed down beside the stump, and its mouth closed with the usual rubber sheet and sponge dressing. Some of the cases in which I have performed this operation have made remarkably quick and satisfactory recoveries; others have had evidence of serious trouble in and around the stump: in one case the whole cervix sloughed out and was discharged into the vagina, the patient eventually making a good recovery. But what has chiefly deterred me from more frequently operating by the intraperitoneal method is the occasional fatality from hæmorrhage. I lost some cases myself in my early operations, and though I have not had this misfortune now for many years, I see occasional reports of them: moreover, I have reason to know that others happen which are not reported; and I greatly doubt whether the intraperitoneal method would hold its own, if really reliable statistics of the extra- and intraperitoneal methods could be obtained.

*Comparison of Results obtained by the Two Methods.*—In order to satisfy myself, in so far as my own results go, whether my impressions were correct, I have been most carefully through my case books, and weeded out all the cases in which some unusual complication — such as pregnancy, the presence and removal of a large ovarian tumour, or the presence and removal along with the fibromyoma of a large suppurating calculous kidney — could specially affect the result. I then classified the cases according to the extent of the operation, and the method of dealing with the remains of the uterus. I find that the results completely bear out the impressions I had formed, or rather support still more strongly the extraperitoneal method, with Koeberlé's *serre-nœud* for the ordinary run of cases. Complete removal of the uterus, including the cervix, has succeeded still better, all my cases having recovered; but they are few, and the method is not suitable for all cases.

I have not only weeded out such cases as I have named above, but I have put into a separate class those formidable cases in which a very large tumour grows either into (between the folds of) the broad ligament, or under the peritoneum; cases in which a large amount of enucleation has to precede the formation of a pedicle, and in which a large ragged cavity is left beside the stump, either in the broad ligament or under the parietal peritoneum. At a recent discussion in America it was proposed, and I think very properly, to consider these cases as a separate class. Operations for the removal of such tumours are among the most formidable the surgeon has to perform, and among the most dangerous to the life of the patient. It is absurd, therefore, to class them with



cases in which the wire of the *serre-nœud* encloses the whole uterine pedicle and one or both ovaries; or in which the wire readily takes the pedicle after the ovary or ovaries have been tied off.

The results of my research are as follows: — Cases in which the *serre-nœud* could be employed without extensive enucleation have a mortality of just under 8 per cent. Cases in which a formidable enucleation has to be done have a mortality of 32 per cent. Cases treated by ligature and suture (intraperitoneal) have a mortality of 50 per cent. Removals of solid outgrowths (subperitoneal tumours), or of pediculate fibrocysts, or enucleation of cysts, in all of which the uterine cavity is not opened into, have only a mortality of 7 per cent. Those in which the cavity is opened, but the body of the organ not removed, have in my experience been the most fatal of all; but their number is too small to permit a statistical appreciation of results.

Cases in which the whole uterus has been dissected out have, as I have said, all recovered.

In looking at these results it must be borne in mind that they include all my early work when the whole of these operations were in their infancy, and only occasionally attempted; and as I early became dissatisfied with the intraperitoneal method, my results under this head belong to my early work alone: doubtless had I worked more at it the results would have improved, but the gap between 8 per cent and 50 per cent wants a good deal of bridging over. Then also it must be borne in mind that this 8 per cent mortality includes all my early work with the *serre-nœud*; and, as practice with it has reduced this mortality by fully one-half, the cases which are suitable for the *serre-nœud*, and in which there is no unusually serious complication, may fairly be said in experienced hands to have a mortality of only 3 or 4 per cent. My impression is that my results in the series of enucleation cases would have been better if I had performed a true hysterectomy, and excised the remains of the cervix as well. It is the combination of the large ragged cavity, from which the base of the tumour has been enucleated, with the sloughing stump which leads to the high mortality in this class of cases.

The manifest objections to the extraperitoneal treatment of the stump, and the search after some surgically complete and satisfactory intraperitoneal method, have led to a large number of suggestions; some good and likely to bear good fruit, and more bad and sure to die practically stillborn. American surgeons are now rather taking the lead in this new departure. German, French, and Belgian surgeons run them hard, however, with novelties in method, and some excellent results. Great Britain seems to be dropping a little behind, and resting on the extraperitoneal method; though we shall certainly have to reconsider the question with such results from intraperitoneal work as have been obtained by Baer, Zweifer, Chrobak, Péan, Richelot, Doyen, Jacobs, Martin, Bardenhauer, Eastman, and others.

I now proceed to describe some of the suggested modifications in the

intraperitoneal methods which I think most valuable and likely to survive; and I shall also mention some that I do not think well of in order to point out objections and to warn off my readers from them.

Before proceeding to describe some of the best of the many modifications recently suggested and practised in the performance of this operation, it will not be out of place to give a brief account of the early work at the operation, and its gradual establishment among the recognised surgical procedures. The early operations were nearly all stumbled into when the surgeon expected to perform ovariectomy; and, as might be expected of an operation which still, with all our advances and experience, often taxes to the utmost the skill and nerve of our most expert specialists, they usually ended in disaster. Then came Koeberlé's *serre-nœud* and a new era dawned. Péan in Paris, Koeberlé himself, Kalténbach and Hegar in Germany, Keith in Scotland, and Bantock and myself in London, each did a considerable number of cases, and chiefly difficult cases with large tumours, because it was only in such that it was considered justifiable to operate at all; and yet the success was very fair. Now and again it was found impossible to apply the *serre-nœud*, and some intraperitoneal method was adopted, with some increase of knowledge for the surgeon, but only very occasionally with a result satisfactory to the patient. When an intraperitoneal case did succeed, the convalescence was more rapid, and the immediate result more satisfactory, than with the extraperitoneal method. I did my first operation at the Samaritan Hospital in January 1877, choosing deliberately the intraperitoneal method, and securing the stump by silk ligatures with a successful result, nearly two years before Schroeder first called attention to that intraperitoneal method which will always be associated with his name. Disappointed by results in succeeding cases, I tried to improve my intraperitoneal method, but without much success. I had not then fully adopted Listerism in abdominal surgery, and I fell back upon the extraperitoneal method, using Koeberlé's *serre-nœud*, and a single pin devised by myself to support the stump. Schroeder first suggested his method in 1878, but did not fully publish it, with cases, till 1882, and he had a mortality of 30 per cent, a rate which was never improved to the end of his work, which consisted of 164 cases, published by Hofmeir. Some of his followers, however, were much more successful. Breunicke of Magdeburg had a series of twenty-one cases, all successful. Fritsch of Breslau, having by the extraperitoneal method reduced his death-rate to 7 per cent, was still dissatisfied, and went to Schroeder's method, with what success I do not know.

*Baer's Operation.*—In 1891 B. F. Baer of Philadelphia first performed this operation, and in the following year he published the method with some successful cases. I give it the first place among the new procedures which I describe, because I think it is the most surgical, and at the same time the most likely to give good results in the hands of competent imitators. His own results have been splendid. I give the details of the

operation as first published by him in the *Transactions of the American Gynaecological Society*, vol. xvii. 1892, p. 234.

The ovaries are tied off by a single ligature passed close to the side of the tumour, and not including the tubes, the ligature being also passed through the outer edge of the broad ligament; then the uterine arteries are separately ligatured on each side, the tumour and uterus are cut away, any points of hæmorrhage are secured by separate ligatures, and the cervical stump is allowed to drop back into the peritoneum. The retraction aids in stopping any small hæmorrhage, and the edges of the broad ligament close in over the stump, so that there is no need for suturing of flaps over it: he does not object to this, however, if it appear necessary in any special case. The mucus plug in the cervical canal is not disturbed either before or during the operation; and on this, and on the absence of all ligatures or sutures in the stump, he lays great stress. He claims for this procedure that the vaginal portion of the cervix maintains its position as the keystone of the vaginal arch, and preserves the strength and shape of the lower part of the abdominal cavity. He does not fear any serious hæmorrhage from the cut surface of the cervix if the ovarian and uterine arteries have been securely ligatured; and he does not believe in the necessity for any drainage in abdominal surgery. The method at once commends itself to the surgical mind. Döderlein's researches, which show that the cervical canal, when not interfered with, does not contain septic organisms, give great support to Baer; but in many patients the cervical canal has been interfered with before they come to the operation; in others the section has to be made through a large open canal full of clot or bloody mucus, yet in Baer's papers I fail to find any suggestion for dealing successfully with these cases. The plug does frequently exist, and I have already in this paper referred to its presence, but I did not appreciate its value till I read Baer's paper.

Baer published a second paper on his method in the same *Transactions*, vol. xviii. p. 62. In this he says: "The vital principles in supravaginal hysterectomy are — first, control of hæmorrhage by ligature of the blood-vessels in the broad ligaments; second, non-constriction of the cervical tissues, so that there shall be no cause for suppuration; and, third, non-disturbance of the cervical canal, so that sepsis from the vagina may be prevented."

*Dudley and Goffe's Operation.* — I mention this operation next, not because I wish to commend it, but because the authors have claimed for it that it is like Baer's operation, — a claim which, to my mind as to his, shows how little they have appreciated the points of his procedure. They ligature the cervix by ligatures passed under or inside its peritoneal covering, and then they cover in the raw surface with large peritoneal flaps cut without any other tissue in them, and sewn over the stump so as to shut it off from the peritoneal cavity. What is the result? That in order to let out the pus which often accumulates between its raw surface and the flaps, they have, soon after operation, to place their patients in the position for dilatation of the cervix. This result might



have been easily foretold; for they first do all they can to lower the vitality of the stump by ligaturing and separating it from its peritoneal covering, and then they shut it away in a closed space without drainage, or any possible escape for discharge; unless, indeed, the cervix be dilated and forced open by the accumulation. It is a return to my method of January 1877, except that I did not shut up the stump by sewing over the flaps. Inflammation shut it up for me at the bottom of the pelvis, and then the accumulating pus forced open the cervical canal with a little help from me, the pus and a slough were discharged, and the patient eventually got well; but not by my surgery. Goffe has published ten cases operated upon on this method by himself and two other surgeons with a 20 per cent mortality. In any large series I should expect it to be much higher.

*Eastman and Chrobak* have modified Baer's operation, and again, I venture to think, in a decidedly retrograde direction. They tie the arteries as he does, cut across the cervix, and then burn a hole through the stump into the vagina, putting a gauze drain through the hole. Then they suture the cut edges of the peritoneum so as to shut out the stump. This is really making an extraperitoneal operation, of somewhat similar character to the operation of Byford to be next described: the same objections I shall have to raise to Byford's procedure apply also to this; practically a damaged stump is extruded into the vagina, to suppurate, and most probably to slough.

*Byford's Operation.*—In 1889 Henry T. Byford, of Chicago, advocated the carrying of the stump of the cervix into the vagina, through the anterior *cul-de-sac*, by separating the uterus and bladder. After the broad ligaments have been secured, the base of the tumour is temporarily secured by an elastic ligature and pin. The uterus and tumour having been cut away, the stump is ligatured in several portions, the ligatures being left long; an opening is then made into the vagina behind the bladder, and the stump is carried into the vagina and clamped there, the edge of the peritoneum, separated with the bladder, being sewn to the posterior surface of the extruded cervix to shut off the peritoneal cavity. Ancient history, indeed, when we get back to long ligatures and a clamp! This operation courts disaster at every turn. First the cervical stump is damaged by temporary pin and elastic ligature; then its vitality is further impaired by its being ligatured in several pieces; then it is twisted out of its natural position into the vagina; then its posterior surface has a lot of sutures passed into it to shut off the peritoneum; and, finally, it is clamped in the vagina, where, with its long ligatures and septic neighbourhood, it is far more likely to slough than to live. Mainert suggested carrying the stump into the vagina through an opening in the posterior *cul-de-sac*; another modification proposed was dilatation and turning the cervix inside out, an operation which, I imagine, is easier to suggest than to perform. Another equally awkward and dangerous suggestion was to cut down through the cervix itself into the vagina, and then to invert it. All these operations seem to me equally



vicious in principle, and only vie with one another in difficulty of performance. Kelly of Baltimore, suspending the stump in the abdominal cavity by long ligatures, also made a retrograde step in surgery. If any one thing delayed the progress of abdominal surgery more than another it was the use of the long ligature. To find it turning up again is astounding!

*Polk's Operation.*—An account of this operation was published by its author, William M. Polk of New York, in the *Transactions of the American Gynecological Society*, vol. xvii. 1892, p. 215; and, though I believe he has now abandoned it in favour of complete extirpation, it has been sufficiently practised, both by himself and others, to make it desirable that it should be described in this article. I have never practised it myself because I was not favourably impressed either by its "technique," or by its results as seen in the hands of Polk's disciples in this country. It was specially introduced for that most formidable class of cases, to which I have already referred, in which a considerable amount of enucleation is necessary before the base of the tumour can be reached and secured. Hæmorrhage, septicæmia, and prolonged suppuration were among its immediate results, as I saw them; and, in cases which recover, hernia on a large scale must I am sure be common as an after result. He separated the broad ligaments, round ligaments, and vessels from the tumour; then placed a rubber ligature round the base of the whole mass (this would be quite impossible of performance in many of the cases in which I have operated); then made a circular incision all round and stripped down the peritoneal covering, the posterior part carrying some of the muscular tissue as well; the uterus and tumour were amputated within this sac, and all the visible vessels ligatured; then the rubber ligature was removed, any other bleeding points were secured, and the cut surface of the stump was seared with the actual cautery, which was also passed through the cervical canal into the vagina. The edges of the sac were then sutured to the edges of the opening in the parietal peritoneum by strong catgut, and to the whole thickness of the abdominal incision by the ordinary abdominal sutures; the opening left was stuffed with iodoform or bichloride gauze, and the whole covered with an ordinary dressing.

Polk is a strong advocate for ligature of the uterine arteries at some distance from the cervix and outside the ureters, because he maintains that in this situation the vessel is met with as a single trunk, and hæmorrhage from its branches is avoided. I have not been troubled with hæmorrhage in the few cases in which I have ligatured the uterine arteries close to the cervix, and I cannot but fear for the ureters by Polk's method; it is not always easy to isolate the artery entirely as he advises. A study of his own diagram emphasises the danger to the ureter, and shows how useless it is to ligature the branches referred to. He advises also a sort of chain of ligatures in tying off the broad ligaments. I have always found that a single ligature is sufficient, though I always transfix with a double silk and leave one loop untied in case of any

emergency. I doubt both the necessity, and the advisability, of so tying the uterine artery as to secure also its paravesical and vaginal branches.

The difficulty in dealing satisfactorily with the cervical stump has led many operators to consider whether it would not be better to remove the stump entirely, thus performing complete extirpation of the uterus. I have performed this operation four times; all the patients made excellent recoveries, and the after results have been very good. I have recently examined two of the patients, and have been agreeably surprised by the satisfactory condition of the vagina: the shortening and shrinkage is not nearly so marked as in some cases in which the cervical stump has been left, and the vaginal vault has preserved its firmness and shape; so that I think the objection to the operation in this direction need not deter us from its performance in suitable cases.

I will briefly describe the operation as I perform it, and then refer to the modifications now practised both by Eastman of Indianapolis, and Chrobak of Vienna, and also to the modifications of other operators.

**Complete Abdominal Hysterectomy.** — The broad ligaments are ligatured off as in the other methods; if it be desirable to leave one ovary this can readily be done by transfixing and tying between it and the uterus. To stop back bleeding pressure forceps or temporary clamps are applied to the uterine side of the cut broad ligaments; the anterior and posterior peritoneal coverings of the uterus are incised and peeled back, fine ligatures or pressure forceps being applied to bleeding points; the finger is then pushed down between the tied off broad ligaments and the side of the uterus, till the uterine artery is felt pulsating, and it is then ligatured by transfixion, taking care to keep close to the cervix so as to avoid the ureter, the opposite one having been secured; the vagina is opened, behind the bladder, by cutting on the point of a sound pushed up through the vagina by an assistant; a sponge is pushed through the opening into the vagina to prevent fluid passing from it into the peritoneum; the tumour is held well up in a central position so as to drag slightly on the top of the vagina, and then the point of a long pair of scissors, curved on the flat, is run quickly round the top of the vagina, the tumour, uterus, and cervix are lifted away, and any bleeding points in the cut edges of the top of the vagina are rapidly secured by pressure forceps. All the bleeding points are then secured with fine carbolised silk, either by simple ligature or transfixion, care being taken to draw the edges of the broad ligament and divided peritoneum as much together in this process as possible, so as to reduce the size of the opening into the vagina. The vagina is well sponged out and plugged lightly with a long strip of iodoform gauze; a Keith's glass tube is placed in the pouch of Douglas so that any blood or serum running back into this pouch from the cut edges of the vagina and peritoneum may be rapidly removed, and the abdominal incision is entirely closed round the drainage tube: this tube is only left in for 24 or 48 hours, by which time oozing has ceased and the vaginal plug has established a good capillary drain from the top

of the vagina to the vulva; the orifice of the latter is kept constantly dry by a frequently changed plug of salicylic wool, or other dry antiseptic absorbent material. For the first few days the urine is removed every few hours by the catheter, to avoid soakage into the vaginal plug. I prefer to leave this plug in place till the fifth or sixth day, if the condition of the patient indicates that it is keeping sweet, as it acts as a valuable support to the upper part of the vagina during the early days of healing, and is a good capillary drain; when it is withdrawn I carefully syringe the vagina myself with an antiseptic douche (usually warm 1 to 2000 corrosive sublimate, or straw-coloured iodine and water, using the latter till it returns without losing its colour). I repeat the douche night and morning, as long as the iodine-and-water solution is decolorised, or as long as there is any discharge. I never put any fresh plug into the vagina, as it is not at all necessary, and I think the manipulations necessary for its introduction are a source of danger.

I have never been able to understand the great trouble taken by most abdominal surgeons to shut off stumps and raw surfaces from the peritoneum: all experience shows that if the operation be aseptic, effusions of blood are much more rapidly and harmlessly absorbed by the peritoneum than by torn and cut cellular tissue; and experience likewise teaches that adhesions to any raw surface left free in the peritoneum are very rare. Damaged surfaces, on which peritoneum remains, much more frequently adhere. If asepticity be not quite assured it is easy to drain with a glass tube. In my opinion, it is infinitely more dangerous to shut up cut and torn tissues in a cavity like the vagina.

Bardenhauer and Eastman deserve the chief credit for the perfection of the operation of complete extirpation. Chrobak, a close follower of Eastman, has also been most successful with his cases of complete extirpation. This latter operator performed the operation in two stages, first, he removed the uterus and tumours as in ordinary supravaginal hysterectomy, and then he removed the cervical stump. Early in 1891 he reported a series of 17 successful cases by this method; but in a later paper in the same journal (p. 713) he advocates retention of the cervix, ties the uterine arteries, dissects off peritoneal flaps, excises the tumour, burns through the cervical canal with Pacquelin's cautery, puts a gauze drain through into the vagina, and sutures the peritoneal flaps.

Polk, Krug, and Edebohls have given up doing the operation in two steps, and they remove tumour, uterus, and cervix in one mass much in the same way that I have done; but they suture the opening in the peritoneum, a proceeding which I believe to be unnecessary. Polk has reported 18 cases with two deaths, and Krug 18 cases also with two deaths. Zweifel of Leipzig has reported 51 cases with only two deaths. He uses a chain of ligatures all interlocking, silk for the broad ligaments and catgut for the cervix, cuts peritoneal flaps and ligatures inside them, passes Pacquelin's cautery through the cervical canal into the vagina, and finally sutures his peritoneal flaps together so as to shut off the field of operation from the peritoneum.



*French and Belgian Surgery and Forceps.* — Instead of using ligatures, the French and Belgian surgeons have for some time past been using successfully various forms of forceps for clamping the broad ligaments. Mr. Greig-Smith in this country some years ago introduced a vaginal clamp for application to the broad ligaments in vaginal hysterectomy, which I ventured slightly to modify; but I am not aware that it has been much used. In the hands of Richelot, Doyen, Jacobs, and others, remarkable success has been obtained in the removal of small fibroids by the vagina by the use of various forceps. Richelot has had 38 cases with only one death; Doyen, 22 with one death; and Jacobs of Brussels, 22 with no death. These results compel our admiration for the surgical skill of the operators; but in this country we have not yet become convinced of the necessity, or even of the advisability, of operating at all upon these small fibroids.

For the cure of moderate sized tumours I still prefer simple removal of the ovaries and tubes; and I believe that the patient is in better condition after this operation than after a total extirpation of the uterus by the vagina, though the cure may be less showy. I am sure that there is something faulty in the methods of operation, when surgeons do not get good ultimate results from this operation; in my hands the results have been entirely satisfactory, and I am constantly seeing old patients whose condition thoroughly bears out this statement. Before proceeding to describe this operation, I will summarise the various methods of performing hysterectomy. The oldest extraperitoneal method with the wire *serre-nœud* of Koeberlé, in spite of all that has been and can be said against it, still is probably by far the commonest procedure. The elastic ligature and pin never seems to have become a generally favourite method. Total extirpation, I think, now comes next; and would, I think, soon hold the field alone, if the difficulties with regard to the roof of the pelvis, and the damage to the vagina, could be satisfactorily overcome.

Of the intraperitoneal methods, that of Schroeder is practically abandoned on account of its mortality; Baer's operation is certainly the most promising of these methods. Then there are the various pressure forceps and clamps, introduced by Richelot and others, for total extirpation without ligatures. The various methods for extruding the stump of the cervix into the vagina are procedures which I venture to predict will rapidly disappear. The method which will enable the surgeon to perform an absolutely aseptic operation will be the operation of the future; but the difficulties are so great that it has not yet been introduced, and when it is it will also have to combine with asepticity, a sound abdominal scar and a practically normal vagina.

It is evident that all the difficulties of the operation still centre round the method of treating the stump; time and wider experience alone can settle which method is best.

**Removal of Ovaries and Tubes for Cure of Fibromyoma.** — I must now describe the operation for the removal of the ovaries and tubes (uterine appendages), a procedure which, in a certain class of cases, may properly



supplant the more serious mutilations we have been considering. Before commencing an operation for uterine fibromyoma, I always tell the patient and her friends that, though it is my intention to remove the appendages or to perform hysterectomy as the case may be, I must be free to revise my decision, if I think it advisable to do so, after I have opened the abdomen; for when we can see and handle the parts, we find cases in which the one operation is obviously more suitable than the other. Removal of the appendages is undoubtedly the proper operation to perform in those cases in which the fibromyomas though small, and still confined to the pelvis, are causing serious hæmorrhage or serious pain. Hysterectomy, in most of such cases, would be especially difficult and proportionately dangerous; while the removal of the appendages may usually be accomplished without any unusual difficulty, and with every prospect of a cure, immediate as regards the hæmorrhage or pain, and more gradual as regards the disappearance of the growths, which cause these outward symptoms. Another class of cases for which removal of the appendages may often be substituted for hysterectomy, is that in which we have to deal with a moderate sized tumour, involving more or less of one uterine wall; the ovaries being still separated and separable from the mass by manageable pedicle; tumours varying in size from that of a cocoa-nut to that of the head of an ordinary child of ten or twelve. Such cases often yield very good results from this operation, the tumour disappearing quickly after it, and leaving the patient in very good and comfortable condition. If, however, in such a case the ovaries, or one ovary, are found sessile, and so flattened out over the tumour that it is difficult to tie their bases without fear of secondary hæmorrhage, or without leaving some portion of ovarian tissue behind, it is far better to proceed to hysterectomy. There are cases which are equally suitable for either procedure; then we may be guided by what we have already said to the patient, or by her probable future: thus in the case of a young married woman, or of one who is going to marry, it may be advisable to perform hysterectomy and leave an ovary; whereas in a woman nearing the menopause, and either childless or unmarried, it may be better to remove the ovaries. The need for a quick recovery may also influence us in deciding the matter; recovery after hysterectomy being usually much quicker than after removal of the appendages, when the tumour is left to be gradually absorbed. Fibrocysts, blood-cysts, myxomatous or œdematous fibromyomas, and those which are degenerating rapidly (breaking down), are not suitable cases for this operation.

There can be no doubt that the operation of removal of the appendages, in suitable cases, is less dangerous to life than that of hysterectomy, and in my own hands its after results have been excellent. I know of two cases only in which the tumours have not entirely disappeared; and one of those, for reasons too long to enter upon here, is not a test case: the other would, I believe, have recovered if she had given herself time, but she got into the hands of the electricians. The objections to the operation are that, in order to obtain a perfect result, it is absolutely necessary

to remove both ovaries entirely; and that in many cases there is a rather slow convalescence, one which may extend even to a matter of years, before the tumour is entirely absorbed, and the pelvic discomforts of its presence entirely gone; the discomforts incident to change of life, too, are usually more marked after this operation than after hysterectomy. When it has been decided to remove the appendages, the operation is precisely similar, in its early steps, to those already described. After carefully opening the abdomen and stopping all oozing from the abdominal incision by pressure forceps, or fine carbolised silk ligatures, the ovaries and tubes are sought for and, if found to be sufficiently free from the tumour, are tied off by transfixion just as in ovariectomy for tumour. I always ligature both pedicles securely before cutting anything away, because the necessary manipulation of the tumour in getting hold of and ligaturing the second set of appendages, may put a dangerous strain upon the pedicle already tied; for these pedicles are always rather short, so that not much of a stump remains on the distal side of the ligatures. I am always careful in transfixion to puncture through the utero-ovarian ligament, if this be possible; as puncture through it is free from risk of hæmorrhage, and gives a firm hold for the ligatures: but sometimes the ligament is so spread out over the surface of the tumour, that it is almost impossible to transfix it without risk of wounding some of the veins immediately under it; in this case it is better to select a thin and bloodless bit of the broad ligament for puncture. Puncture of a vein is, in my opinion, the great risk in this operation; even in ordinary ovariectomy it is apt to lead to phlebitis, but in the latter operation it is generally possible to get a fresh transfixion behind the vein puncture, while in the operation under discussion there is rarely room to do this, and one has to leave the silk passing through the vein and trust to control the oozing by another ligature merely tied behind it. In one case I had gangrene of the leg from phlebitis following puncture; and in another case, though the symptoms were somewhat obscure, I always myself believed that some clot and trouble in the pelvic vein led to the death of the patient. I transfix and tie both pedicles; I then cut away both ovaries and tubes, and then apply a third No. 2 carbolised Chinese twist ligature round the whole of each pedicle. I always sponge out the pelvis, too, before completing the ligature. It is rarely necessary to drain in these cases, which is fortunate, for it is very difficult to get the glass tube to lie nicely behind the tumour without bringing it out so high in the incision that it lies awkwardly among the intestines and is apt to irritate them.

**Hysterectomy for Procidencia.**—This operation I have never performed. I have never seen a case which seemed to me to justify so extreme a proceeding; indeed, I have never myself met with a case in which the uterus could not be kept up, so as to make the patient comfortable, by some form of vaginal support. I can understand, however, that some patients would rather run the risk of operation, than have the constant trouble and annoyance of a support. The removal of the uterus should in such a case be performed through the vagina; and as I have not

had occasion to refer to kolpo-hysterectomy, I will briefly describe the method I prefer. Kolpo-hysterectomy for malignant disease is, I understand, included in the article on "Cancer of the Uterus," and does not fall within my province.

**Kolpo-Hysterectomy.** — For some days before the performance of this operation the patient should be prepared by frequent large anti-douches. I think it is best to vary them, using in turn 1 to 60 carbolic acid, 1 to 1000 corrosive sublimate, and iodine and water of deep straw colour. I always begin the preparation by thoroughly cleansing the uterine cavity with tr. of iodine applied on cotton wool by means of a Playfair's probe, and, if possible, a free washing out with iodine and water through a double action tube. For the forty-eight hours preceding the operation the vagina should be washed out thoroughly, every six hours, with a full douche of one or other of the antiseptic solutions named above. The last douche is to be given just before the patient is placed on the operating table.

The vulva should be thoroughly washed with carbolic soap night and morning for some days before the operation, and again when the last douche is given; especial attention being given to the folds between the thighs and inside the labia, and between the latter and the clitoris. I always shave off what hair I wish to be removed after the patient is under chloroform, as it only takes a few seconds, and is a very disagreeable proceeding if done during consciousness. The patient should be placed on her back with head and shoulders low, and the legs supported in the lithotomy position by Clover's crutch. The operator should sit at the foot of the table, with his back to a window. A strip of iodoform gauze is passed into the uterus so as to block the cervical canal, and the cervix is seized by a strong locking volsella with curved handles, so that an assistant can move the uterus about freely, as directed, with as little obstruction to the vaginal outlet as possible. The operator pulls the uterus well down to the outlet, and then hands it to the assistant, who moves it backwards and forwards and from side to side as required during the subsequent steps of the operation.

The operator now divides the mucous membrane all round the cervix, as high up as the vaginal reflexion will admit, taking care to make only a superficial division at the sides over the vessels, and cutting well through into the cellular tissue in front and behind. He then pushes back the mucous membrane towards the bladder, and towards the pouch of Douglas, till the sense of resistance warns him that the limit of safety is reached. Then he either pushes his finger through into the pouch of Douglas, or perforates it with Lister's sinus forceps, expanding the blades as they are withdrawn to allow the finger to pass in. The peritoneum is then divided right across the back of the pouch, and next between the bladder and uterus, the puncture and section here being aided by the finger hooked over the fundus. A large carbolised sponge is now pushed into the lower part of the peritoneum to keep back the intestines and omentum, and prevent any fluid or air from the vagina being sucked into that cavity; and



the securing and separating of the broad ligaments is then undertaken. Different operators differ greatly in their method of performing this part of the operation. I prefer to snip the ligaments gradually through with scissōrs, keeping the blades close to the sides of the cervix, and seizing and tying each bleeding point, generally by passing a fine silk under the open mouth of the vessel, a much slower proceeding than many of those employed, but one having the merit of being very sure. The operator is absolutely free from risk of secondary hæmorrhage; he does not leave great pieces of tied tissue to suppurate or slough; and he sees exactly at each step whether the tissue cut through be normal or infiltrated. If the uterus is firmly dragged down and over to the side opposite to the one being divided, the trouble from back bleeding from the uterus is but little; but if there be any, it is easily checked by the application of a slender clamp, or long, thin-bladed forceps. When both sides have been divided the uterus is drawn down and removed, the sponge is removed from the pouch of Douglas, the vagina is packed up lightly to the circular incision at the top with iodoform gauze, care being taken not to make this packing separate the edges of the wound, and a sanitary towel, fastened on by a T bandage, completes the dressing. The sanitary towel should be frequently changed. The vaginal plug can in most cases be safely left for five days to a week, when it is gently withdrawn, and the vagina carefully douched with iodine and water. I always do this myself night and morning for the first week after the removal of the plug. I never use any sutures to bring the edges of the divided peritoneum together, and I find that if the plugging is lightly and properly done, it gives just the necessary support, the edges fall naturally together, there is no fear of intestinal prolapse, and drainage into the plug, and through it, is free and efficient. I always have the catheter used while the plug remains in, to avoid wetting it with urine. In performing this operation for proclivencia, it is necessary to remember that the bladder and ureters, and even the intestines, are very apt to be much displaced, so that much greater care is required in the cutting parts of the operation. In such cases the method I employ is especially likely to avoid injury to these displaced organs.

I sometimes ligature the uterine arteries by transfixion before commencing the gradual division of the broad ligaments. This is not always easy to do, but, if it can be done, it undoubtedly saves hæmorrhage, and renders the rest of the operation easier. Some operators transfix and tie the broad ligaments on each side in a mass; others do this after inverting the uterus into the vagina; others bisect the organ and remove it in two halves. The French and Belgian surgeons have been obtaining the most brilliant results by the use of pressure forceps applied up each side of the uterus, left on the broad ligaments for some hours, and then carefully removed. The time during which it is necessary to leave them on has been gradually reduced till, I believe, some operators think twelve hours long enough. Of course the sooner they can be removed with safety, so far as fear of hæmorrhage is concerned, the less the risk of



sloughing of the tissues crushed between their blades. This unfortunate result of their use, which must happen to some extent in all cases, has led to septicæmia in not a few. This is to me the great objection to their use. As I have already said, Mr. Greig-Smith, several years ago, introduced a very efficient little clamp for securing the broad ligaments, in which I ventured to make some slight modification, but I have never used it on the living subject, and I think if I ever do adopt this method I shall prefer to use some of the forceps now in use in France. Richelot's seem admirably adapted for their work, and his brilliant success bears witness to their excellence.

**Hysterectomy for Intractable Inversion.** — It is very rarely that some of the excellent repositors which have been invented will not reduce an inverted uterus; but now and then a case has been overlooked and left so long untreated that abnormally related parts have grown firmly together, and nothing is left but to remove the organ. Formerly it was thought sufficient to amputate the mass with an *ecraseur*, and I have myself successfully performed this operation. It is, however, a most unscientific procedure, and has in several cases ended in serious disaster — a coil of intestines or other important organ having become involved in the amputation.

*The diagnosis of complete inversion* should not be difficult; combined examination, with aid of an anæsthetic if necessary, will soon show the presence or absence of the uterine body in its proper place in the pelvis or abdomen. The finger in the rectum will recognise the depression in place of the uterine body; in the vagina the absence of the os uteri, and possibly the detection of the openings of the Fallopian tubes, will render the diagnosis absolute. It may occasionally be a little difficult at first to diagnose between inversion and a large polypus, but attention to the above points should prevent error. If both conditions should be present, the polypi having led to inversion, then greater care may be necessary to avoid unintentionally including the uterine body in the operation for removal of the polypus.

Immediate removal by cutting, with ligature of the divided vessels by the *ecraseur* or the cautery, were the methods formerly used, and with a terrible mortality. Gradual removal by compression, as may be supposed, was not much more successful, though the elastic ligature certainly reduced the mortality considerably.

The method of first compressing the mass with an encircling ligature, so as to produce adhesions between the abnormally opposed serous surfaces, and then amputating below the constriction, very considerably reduced the mortality, but it still remained over 15 per cent. There can be no reason why complete excision, carefully performed on the lines laid down for excision in proclivencia, should not be attended with good results; but it would be necessary to bear in mind the changed relation of parts brought about by the inversion, and to modify the exact details of the procedure accordingly.

**Operations on the Gravid Uterus.** — I now pass to the consideration

of the various operations which have been suggested for dealing with the gravid uterus, when the natural passages, either from deformity of the bones of the pelvis, or from the presence of a neoplasm, do not admit of the delivery of a living child.

I think it is beyond the scope of my article to deal with *symphysiotomy*, *pelviotomy*, and *pubiotomy*. The cases in which these methods would be employed must be very unusual, when we have such a range of successful procedures as the improved Cæsarean section, Porro's operation, and complete extirpation to choose from.

*Regional Anatomy of the Pelvis at Term.* — Polk and Greig-Smith, by their careful dissections, have thrown valuable light upon the changes brought about in the regional anatomy of the pelvis by pregnancy, especially in the relations of the peritoneum, the ovarian and the uterine arteries, the uterine ligaments, and the ureters.

Briefly these changes are, elevation of the pelvic peritoneum, with great laxity of the underlying cellular tissue; the broad ligaments become abdominal instead of pelvic, and triangular in form instead of quadrangular; their layers are separated and more loosely attached. The arteries are much enlarged, especially the ovarian; the uterine artery is elevated so that it is in part removed from the uterine wall; its relations to the ureter remain much the same. The ureters are elevated along with the bladder and vagina, and lie very close to the latter along its antero-lateral surfaces. At the end of the first stage of labour the ureter crosses the line of the os uteri obliquely at the juncture of the anterior and middle third; and, at the level of the external os, the space between the ureter and rectum is twice as great as the space between the ureter and bladder.

*Cæsarean section* would, I suppose, hardly come under hysterectomy and allied operations; but as it is one of the steps in the other two operations, I shall briefly consider its performance.

The terrible mortality of the old Cæsarean section led to the equally sad destruction of infant life by craniotomy and other barbarous proceedings; but now with the splendid achievements of abdominal surgery all these horrors are passing away, and we have only to consider which surgical procedure is most suitable to the particular case, and how best so to perfect the procedure as to save the lives of the largest number of mothers and children. The surgeon who decides upon performing Cæsarean section should always be prepared with the instruments necessary for proceeding to Porro, or to complete hysterectomy; if circumstances arise which render either of these procedures necessary.

*The improved Cæsarean section* owes its present success chiefly to the German surgeons, especially to Sænger and Leopold. The former first suggested the improved method of suturing the uterus, and the latter was the first surgeon to carry it out successfully. Many small details which contribute to success, and require care, will be duly noted in describing the operation; but the detail which has brought about such an astonishing difference in results between the old and the new Cæsarean

section is the method of closing the uterine wound. Another most important element in the recent success is the performance of the operation at an appointed and carefully selected time — not during the first stage of labour, but, as in any other abdominal operation, after due and careful examination and consideration of all the conditions, and, more important still, after due and careful preparation of the patient. Thus everything is carried out in order and without hurry or excitement, conditions which so frequently brought disaster in the old operation. Another great advantage of the “elective operation” is that it need no longer be performed by the inexperienced family doctor, but by the trained and experienced abdominal surgeon; and I maintain that there is no great operation of surgery which so clearly demands that its performance should be placed in the hands of the experienced operator. When it was thought not advisable to operate until labour had commenced, such an arrangement was often impossible, but now the patient can be carefully prepared and placed in some apartment suitable for operation; she should also have the benefit of skilled surgery. The preparation of the patient should be precisely the same as for any other abdominal operation; the vagina and external genitals should be carefully cleansed some days beforehand. Then, just before the operation, the surgeon should examine the cervix, and satisfy himself that it is patent, and will allow of proper vaginal drainage, and also examine the uterus and see that it contracts properly.

*Operation.*—The abdominal incision should be from 5 to 6 inches long. It should commence above and to the left of the navel, and be carried down only to a point about  $2\frac{1}{2}$  inches above the pubes—the elevation of the peritoneum between the uterus and bladder will place the latter organ in danger if it be carried lower. As soon as the uterus is exposed, the assistant standing opposite to the operator should place his hands deep in the flanks and under the uterus on each side, so that he can press it forward into the incision, making it slightly bulge through it. Then a large flat sponge is placed between the uterus and the anterior parietes on each side. If the assistant attends quietly and carefully to his work all through the operation, always keeping the uterus well pressed up against the anterior parietal peritoneum, no fouling of the peritoneum is possible; but if I had to perform the operation without an assistant upon whom I could rely for this help, I should substitute the long incision, and turn the uterus out of the abdomen before incising it.

The incision into the uterine wall is made vertically, beginning well up at the top of the abdominal incision, and not carried too low, for fear of wounding branches of the uterine artery.

If the hæmorrhage be very severe, a few pairs of my T-shaped forceps may be rapidly applied to the edges of the cut, but if the use of forceps can be avoided it is better, as all traumatism is bad. The operator then seizes the child by the head and rapidly extracts it. Should the feet present he may extract by them; but in this case care is required lest the uterine wound close tightly round the child's neck. If this should

happen it must be freed at once by enlarging the wound in an upward direction, lest it be torn down into the lower segment of the uterus. The cord should then be rapidly divided between two pairs of forceps, or two ligatures which can be almost as quickly applied, and the child handed to an assistant or nurse. A hypodermic injection of ergotine should then be given, and, if the mother's condition allow it, a short pause be made to allow of natural separation of the placenta. If this do not occur, and blood is being lost, the placenta must be peeled off and extracted, the uterine cavity thoroughly cleared of the secundines, and a strip of iodoform gauze passed through the cervix to act as a drain.

*Closure of the Uterine Wound.* — The all-important step in the operation has now to be carried out, and the uterine wound closed by Sanger's suture. First a row of deep silk sutures (No. 2 Chinese twist) is placed; each suture enters the peritoneum about half an inch from the edge of the wound, slants obliquely through, and is brought out in the muscular wall some little distance from the uterine cavity. These sutures are three-quarters of an inch apart, and the uppermost and lowermost ones should be placed well beyond the limits of the incision; then a second row is placed, two sutures between each of the deep ones, the needle enters the peritoneum a little nearer its cut edge than for the previous ones, and comes out more superficially in the uterine wall; then it is carried up and through the cut edge of the peritoneum on its own side, then through the cut edge of the peritoneum opposite side of the incision, and through the cut edge of the uterine wall about its centre, and out obliquely through the peritoneum; this row of sutures is also carried beyond the ends of the incision. When all are in place the superficial ones are tied first, and these will invert both edges of peritoneum; then the deep ones are tied, and these bring the serous surfaces firmly together, almost burying the superficial sutures. Should the apposition of the serous surfaces still not appear close enough all along the line, a fine continuous superficial suture may be applied to make everything still more secure. The essence of the method is not to let any of the sutures come near the interior of the uterus, and to bring two good broad strips of inverted peritoneum firmly into contact all the way along the incision. If the assistant has done his work well by keeping the uterus well against the parietes there will be no need to sponge out the peritoneum; all that is necessary will be to remove the flat sponges, and close the external incision.

If it be desirable to prevent the possibility of future pregnancies, the tubes on each side should be ligatured in two places with fine silk, and a small V-shaped portion removed.

If any drainage is desired a small rubber tube may be placed in the anterior *cul-de-sac*, and sutured into the lower angle of the abdominal wound.

If the uterus contracts properly the case will probably do well, often as well as after an ordinary confinement; but if, before the abdominal incision is closed, the uterus is seen not to be contracting properly, then



it may become a question whether it is not better to perform Porro's operation, or a complete extirpation of the uterus immediately.

The literature of the subject of Cæsarean section is now so very large, that I have avoided going into the history of the operation, or attempting to deal with the suggestions good, bad, and indifferent, which have been made concerning its method of performance; I have contented myself with describing, as clearly as I can with our present knowledge, the way in which I think it should be performed.

The only point which perhaps deserves notice to which I have not alluded, is the question of applying temporary intraperitoneal elastic compression round the uterus, at the level of the internal os, during the incision of the uterus and the extraction of the child. I do not think it is necessary in ordinary cases, but if alarming hæmorrhage occur a loop of elastic tube can be rapidly passed round and tightened, and its crossed ends secured in a pair of Wells' large pressure forceps. The objections to its use are that it adds another element of risk in the traumatism produced at its site, and, if the operation be at all prolonged, that it asphyxiates the child. I think, however, it may be worth while always to place a rubber tube in position round the neck of the uterus before incising it, so that if necessity arise it can be quickly tightened. If it has to be applied at an urgent moment valuable time will be lost, and the peritoneum will be fouled with blood, and very likely with uterine contents also.

The after treatment is the same as for any other abdominal operation, with the addition of attention to the condition of the mammæ, and warm antiseptic vaginal douches every six or eight hours. The cervical drain will in most cases gradually come away by itself; but if it do not, it can be gently withdrawn in about forty-eight hours.

*Porro's operation*, first planned and successfully performed in 1876 by the Italian surgeon whose name it bears, was suggested to him by the success of extraperitoneal supravaginal hysterectomy, and is a combination of Cæsarean section with this latter operation. Some 250 cases of this operation have now been recorded, with a maternal mortality of about 50 per cent. Utero-ovarian amputations performed during pregnancy, but before the fœtus is viable, have also been spoken of, improperly, as Porro's.

One of the advantages claimed originally by Porro for the operation was that it would save more mothers than Cæsarean section; probably this was true then, with the old Cæsarean section in vogue; but with the improved and "elective" Cæsarean section I doubt if the claim still holds good.

Another great advantage claimed was that the operator could select his own time, and properly prepare the patient; this advantage now belongs likewise to Cæsarean section.

The patient should be prepared in exactly the same way as before hysterectomy for tumour; that is, the bowels should be well cleared, the bladder emptied, and the vagina and vulva well cleansed by antiseptic

douche, washing, and shaving. Any time near the time of natural delivery will suit quite well for the operation, which, up to the time of full exposure of the pregnant uterus, is performed in exactly the same way as for tumour. When this point is reached the site of the placenta should, if possible, be made out in order that this organ may be avoided in opening into the uterus; this discovery is, however, rarely possible, and more stress has been laid on its importance than I think it deserves. A trustworthy assistant should then grasp the uterus and broad ligaments at the lowest point which he can reach with his hand in the pelvis, so as to be ready at once to arrest the circulation when the uterus is opened; but he should not interfere by closing his hand until the operator is actually beginning to incise the uterine wall; thus the child's blood-supply is not interfered with till the last moment. A rubber tube may also be put loosely round the cervix, as advised in the previous operation, to be secured if necessary. The operator, avoiding the placental site, if this be possible, makes a small incision through the uterine wall and then completes the opening by tearing with his fingers (a modification originally suggested by myself when assisting Dr. Godson to perform the operation); the child is then at once extracted and handed to an assistant, who ties and divides the cord, and gives the necessary attention to the child. The uterus should be packed round with carbolised sponges during incision and removal of the child; and when the latter part of the procedure is accomplished, the opening into the uterus should be plugged at once with a large sponge or sponges, the surrounding sponges quickly removed, and Koeberlé's *serre-nœud* applied round the base of the uterus and the broad ligaments, just above the hand of the assistant, who has been preventing hæmorrhage by firmly grasping it as already mentioned. If it be thought advisable to leave one ovary, it can readily be excluded from the wire at this stage, either with or without its tube; and this I strongly advise in all cases in which the woman operated upon is married and young. As soon as the wire is fixed and screwed up the assistant withdraws his hand, the pin is passed through the uterus immediately above the wire, and the uterus is cut away, great care being taken to pack it well round again with carbolised sponges, and to prevent any escape of its contents into the peritoneum. If there appear to be any necessity for draining the peritoneum, a Keith's glass tube is placed in the pouch of Douglas, as soon as the peritoneum has been sponged out, and the wound closed round it by the usual silk sutures; drainage is, however, rarely necessary in these cases, and is to be avoided if possible, for the reasons already given in describing the operation as performed for fibromyoma. Dry gauze dressing is packed round the stump, which is then carefully treated with solid perchloride of iron; more gauze, held by big, broad, supporting bands of adhesive plaster and covered by a towel pad, and an abdominal binder secured by three safety pins, complete the procedure. The after treatment is precisely the same as after the operations already described, except in so far as it may be modified by any degree of milk fever. A free and

early application of extract of belladonna and glycerine covered with cotton wool and oil silk, repeated every twelve hours, is the most efficient and soothing remedy for painful swelling and hardness of the breasts, a remedy far more efficacious than the evaporating lotions often recommended. The operation described above was suggested by Cavallini, by Michaëlis, and by Blundell, and actually performed by Storer of Boston in 1869 to stop a serious hæmorrhage during the performance of Cæsarean section.

Müller suggested a modification which may be advantageous when the operator has no reliable assistant to grasp the uterus. He makes a long incision, turns the uterus out entire, and surrounds its base with an elastic ligature which is tightened before the uterus is opened. This procedure and the opening into the uterus must be very rapidly done, however, if the child is to be rescued from asphyxia. The method is specially recommended in order to avoid fouling of the peritoneum, but this accident can be easily avoided with proper sponge packing.

*Combined Cæsarean Section and Complete Hysterectomy.* — In certain cases it may be thought advisable to complete a Cæsarean section by the complete extirpation of the uterus and its appendages; it is not necessary to give any special description of this procedure, as the first part is merely Cæsarean section up to the extraction of the child, and the second part is complete abdominal extirpation (hysterectomy) already fully described.

It only remains for me to describe the after treatment of a patient who has been subjected to any form of hysterectomy, and to give a list of the instruments and dressings which should be provided for the operation.

**After Treatment.** — The after treatment is the same after all forms of hysterectomy, for whatever disease performed; and after removal of the appendages. The patient is kept on her back with the knees over a good firm pillow, and the head and shoulders well supported by an inclined plane of pillows. I never let the patient move from this position till the end of a fortnight, when she is in many cases ready to get up; though the separation of the stump in an extraperitoneal hysterectomy may keep a patient on her back for a much longer time. Nothing but an occasional sip of warm water (ice dries the tongue and creates more thirst) is given by the mouth until all sickness, if any there be, is over; and, more important still, till the flatus passes down by the anus: then a little weak tea with plenty of milk, equal parts of milk and hot water, milk and soda water, some of the meat essences, pure clear beef tea, or mutton or chicken broth, may be taken; about the third or fourth day a little boiled fish, or sweetbread, is ordered, and so gradually an ordinary diet is reached.

*Rectal Feeding.* — All my patients are fed by the rectum, every three hours, from the time they are conscious after the operation, till they are taking sufficient nourishment by the mouth; and clear jelly beef tea made as strong as it can be made without salt, is the only thing used for these injections.



*Opium.* — In this injection twenty drops of laudanum are given every six hours, unless I see some reason to omit them; for I am still convinced that the majority of cases do better, and are more comfortable during the first few days, with laudanum than without it. I rarely continue its use beyond the third or fourth day. Any medicine, that it may be necessary to give, is administered also in the injections. If the injections are not well absorbed and the refuse is offensive, the rectum is washed out with half a pint of warm water and rested for half an hour. Two to five grains of quinine mixed with a tablespoonful of port wine are then added to each injection; this destroys septic elements, and the rectum will soon absorb well again. I have seen a patient at death's door from septicæmia, brought on by injudicious rectal feeding, and allowing a lot of decomposing stuff to remain in the rectum. The vaginal pipe of a Higginson's syringe should always be passed into the rectum ten minutes before an injection is given, to allow the wind to pass, and to let any fluid escape, a little soap dish or a towel being placed under its open end to absorb the latter. If the rectum be irritable it is a good plan to wash it out with half a pint of warm water, or with the same quantity of a solution of borax, or boracic acid, to allow it to rest for half an hour, and then begin the injection again. Sickness or retching I treat by large doses of hot water; sometimes a teaspoonful of sal volatile in a tumbler of hot water acts as an excellent quick emetic, and is also a little stimulating. Chloroform sickness is allayed by 15-grain doses of oxalate of cerium in mucilage repeated every three hours. Sometimes when the flatus does not pass, and green sickness is troublesome, a dose or two of white mixture, not repeated often enough or given in large enough dose to act as an aperient, acts like a charm. I give for a dose a drachm of sulphate of magnesia, with a scruple of the carbonate, and a little spirit of chloroform in an ounce of peppermint water.

*Drainage.* — If a drainage tube be used the wound is dressed night and morning, the sponges in the india-rubber sheet washed and re-carbolised, and the fluid in the glass tube carefully sucked out with an india-rubber tube attached to the nozzle of a glass syringe; the rubber tube should have a round hole cut in its side, near the end which goes to the bottom of the glass tube, or it will suck against the pelvic peritoneum and not act properly. It is well also at each dressing to lift the glass tube a little, and to turn it round in the wound; as little bits of fat, or omentum, or even the wall of the gut, may be drawn into its side holes and get strangulated there, causing great difficulty in its subsequent extraction. When there is no longer anything in the sponges, and only a little clear serum in the tube, it is removed. If there be any doubt as to the exact time when it is advisable to remove it, a rubber tube may be slipped through it, long enough for the glass tube to be withdrawn over it, and the rubber one left in for another twelve or twenty-four hours; so that if fluid still gathers it may escape into the dressing. The glass tube does in some cases irritate the peritoneum, causing a flow of serum, and also some trouble with flatulence; and it may be difficult to



decide whether an increased flow of serum be due to this cause or to septicity.

*Removal of Sutures.* — In an ordinary case, where the wound is entirely closed, I rarely dress till the fifth or sixth day; I then remove half the sutures; on dressing again in three or four days I remove the rest, strapping up carefully after each dressing with strong broad straps of adhesive plaster, which is much better than any soft form of roller bandage, as the firm support of the plaster does not allow the intestines to become distended with gas. In extraperitoneal hysterectomy cases, I am guided as to the time for change of dressing by the presence or absence of any staining of the plaster, or by the necessity for tightening the screw; this I often do, however, through a little window without disturbing the rest of the dressing. Usually the hysterectomy cases are dressed about the fourth or fifth day, and then every third day till the stump begins to separate; then I dress every day or every other day, thoroughly dusting everything, as I raise the old dressings, with a little pepper dredger full of finely powdered boracic acid. If this be done the stump will separate without smell, which is a great comfort to the patient, if it be not also a safeguard. I generally leave in the sutures, or some of them at any rate, longer in these cases, as the wounds are very liable to reopen if the sutures are taken out too soon. Whether this tendency be due to the nearness of septic material in the stump, or to the mechanical wedge-like action of the latter, I cannot say: I think both agencies play their part. It is worthy of note that patients operated upon during pregnancy are specially liable to this accident. Careful strapping of the wound for a considerable time after extraperitoneal hysterectomy is advisable, to try to prevent the occurrence of hernia at the point where the stump is fixed; this accident is of such common occurrence that, to my mind, it is the greatest objection to this method of operating. These patients should be specially cautioned not to expose themselves to any risk of stretching the scar, until the changes from soft elastic new tissue to firm, fibrous, old scar tissue have had time to occur. I always order all my patients to wear a good supporting abdominal belt; and I do not let them leave it off till I have examined the scar, and seen that it is firm and linear. I do not in the least believe in the allegation that support weakens the muscles and tends to produce hernia. A little practical observation in a matter of this kind is worth bushels of opinions, and I notice that patients who leave off their belts too soon are very liable to hernia.

*Instruments and Dressings.* — The following are the instruments and dressings which I provide for an operation, whether it be a simple removal of the appendages, or a difficult hysterectomy: —

About twenty-five Turkey cup sponges of varying size, and one large flat ditto. I vary the number from time to time, so that the nurses should really have to count, and not get careless in this most important detail. They are well cleaned in washing soda and water, and after repeated rinsing to get rid of the soda, are placed in 1-20 carbolic lotion,

which, just before the operation commences, is turned into 1-40 lotion by the addition of an equal measured quantity of hot water. If the sponges are thoroughly damp and clean, I believe a very few minutes' soaking in 1-20 is quite sufficient to render them safe, and surgically pure.

A thin mackintosh sheet, large enough to cover the chest and abdomen, and to hang well over the sides of the table, with an oval hole cut in it from 4 to 8 inches long, and 3 inches broad; the edges of the hole being surrounded with an inch broad layer of carbolised adhesive plaster.

A yard of strong adhesive plaster, cut into strips of varying width and length, suitable to the particular case.

A binder made of fine flannel, lined with old calico turned well over the edges of the flannel, so that when the binder is applied the flannel does not anywhere touch the skin.

Some good strong safety pins of the old-fashioned kind, without any cap or contrivance for harbouring dirt.

A couple of packets of carbolised gauze.

One lb. of carbolic acid or absolute phenol, made into twenty pints of lotion just before the operation, so that it is hot and ready for use. An excellent vessel in which to make this lotion is an earthenware or china slop jar, obtainable now in most houses; they just hold twenty pints of fluid. The lotion should be made by dissolving the acid in really boiling water, and then making up the quantity with ordinary hot water.

A small bottle of laudanum for the nurse's use after the operation.

A bottle of glycerine to take the carbolic acid out of my own hands after the operation.

A small bottle of tincture of iodine.

A wide-mouthed bottle of solid perchloride of iron.

A box of bistouries; a Key's director; a long straight needle with a large eye; an Adam's eye hook for picking up the peritoneum; a pair of catch forceps for pulling out the tongue; two dozen straight needles about  $2\frac{1}{2}$  inches long, threaded in pairs with No. 2 carbolised Chinese twist, and arranged in a piece of gauze.

For a hysterectomy, two pairs should be threaded with No. 3 silk for use above and below the pedicle.

Two or three curved, long-handled, perineum needles, armed with a long thread of silk — No. 3 for final tying, and No. 4 for temporary use.

Three or four skeins of carbolised Chinese twist wound on glass reels, Nos. 1, 2, 3, and 4.

At least two dozen pairs of Wells' pressure forceps, some curved, some straight; in a big enucleation hysterectomy more will often be required. A few pairs of my own square-ended forceps. From four to six of Wells' long and strong pressure forceps, some straight, some curved. A couple of long, narrow-bladed, temporary clamps. A pair of scissors curved on the flat. A scissors handled needle holder.

Two or three of Koeberlé's *serre-nœuds*, and a good supply of soft iron wires of various lengths and thicknesses, with one end looped ready for use. The soft iron wire is much to be preferred to the new amalgam,

which is very liable to yield, and allow subsequent oozing. A pair of pliers for tightening the wire and cutting it. A strong, flatheaded corkscrew with loop handle. Some of my pedicle pins with screw cap. A pair of oval-ended, long-handled polypus forceps, with catch on handles, to be used for introducing the sponges into the pelvis. A fine long trocar and canula suitable for exploratory puncture. An assorted series of Keith's glass drainage tubes, a rubber sheet for use with tube, a glass syringe armed with a fine piece of red rubber tube for sucking out contents of glass tube. Some rubber tubing of various sizes suitable for drainage, or to use as a temporary elastic ligature. Uterine and bladder sounds.

J. KNOWSLEY THORNTON.

---

## MALIGNANT DISEASES OF THE UTERUS

**Introductory.**—The task of setting forth the present state of our theoretical knowledge and of our practical methods of dealing with malignant disease of the uterus does not include the consideration of the pathology of cancer in general. We have, however, sufficient material for a more definite and partial treatment of the subject.

Malignant disease, as met with in the female sexual organs, presents certain anatomical naked-eye changes of tissue and a conformation of neoplasms which is peculiar to these parts, but, whatever their clinical importance, they are of comparatively little pathological significance. But there are other considerations—such as frequency of occurrence, causation, and surgical and medical methods of treatment—which are highly important, and which require special exposition on account of the anatomical structure of the parts, the relations of the affected organ to pelvic and other viscera, and its peculiar physiological functions.

The pathology is also to a large extent special on account of the minute anatomy of the parts affected, the relations of their constituent elements to the origin of the malignant process, the methods of invasion, and the extent of the changes produced by the growth of the neoplasm. For an exposition of the present state of the science of bacteriology in relation to malignant disease the reader is referred to *System of Medicine*, vol. i. We have to consider the practice of medicine as well as pathology; and the two subjects are not always so mutually helpful and complementary as might have been expected. Some of the pathologists who have given special attention to this subject may be, perhaps, too prone to attach undue importance to their methods of investigation, to multiply non-essential details, and to magnify unimportant differences, which obscure the view in the direction of general conclusions. They naturally become absorbed in the contemplation of the specimens which are to

them the subject material for observation and reflection; they are not concerned with the aspects of disease and its human interest. The clinician, on the other hand, has ever with him the human interest of the disease, and he looks sometimes impatiently towards the pathologist for practical guidance in dealing with the individual case. It is to him of small interest what name the nomenclature of the decade assigns to a certain conformation of epithelial or connective tissue elements. He wishes to know whether the disease in question is malignant or benign; and he may occasionally be harsh and unjust in his judgments of scientific pathology when the answers are not so prompt and lucid as he may have expected.

In the exposition of malignant disease of the uterus within reasonable limits, considering the inherent difficulties and the present state of our definitely acquired knowledge, I can only, to the best of my judgment, assign the space which I think suitable to each part of the subject; hoping for the early advent of the time when pathology and practical gynæcology will be more helpful to each other than they are now, and the material for their exposition may be more complete and homogeneous. If I err on one side the pathologist may think my work incomplete and unsatisfactory, perhaps puerile and shallow; if I err on the other side, the gynæcologist may consider the result tedious and unintelligible, perhaps pretentious, certainly unpractical.

Cancer of the uterus, as popularly understood, implies the existence of a growth or tumour whose most striking characteristics are—the tendency to spread by sending out roots in all directions from the point of origin, so as gradually to destroy the womb itself; and in the process to produce such symptoms as intense pain and foul discharges, distressing to the patient and those about her, and finally to cause a lingering and miserable death. The popular notion of pain as an essential symptom in such a terrible malady interposes one of the principal difficulties in the way of seeing the cases in the earlier stages of the disease, and of applying the most efficient treatment.

Another popular notion, which I fear is also held in some vague and uncertain way by many members of the medical profession, is that the menopause is associated with irregular and profuse hæmorrhage from the uterus, and even with other discharges from the uterus or pudenda. This widely-accepted theory of a final “cleansing,” as a disagreeable episode necessitating patient waiting for its termination, is one of the principal reasons why long delay so often occurs before women affected with cancer of the uterus seek professional advice; and it is to be feared that it sometimes accounts for the fact that the advice obtained is not always based on precise diagnosis, followed by prompt and effective treatment.

In order to formulate our knowledge, to facilitate the description of symptoms, and to indicate the sequence and relations of processes and phenomena, it is necessary for us to classify the most striking forms which malignant diseases of the uterus assume. We must constantly



keep in mind, however, that these classifications apply with any precision only to the comparatively early stages of the disease; and we must also remember that the terms which we employ only indicate the presence of pathological tendencies producing certain tissue changes. The ultimate facts determining their origin and their relationships are still unknown to us. The malignant diseases that we call epithelioma, carcinoma, and sarcoma, may all be present in the same individual. This co-existence of disease in the various forms implies, so far as we know, no more than a greater measure of some condition of the general health determining degenerations of which our exact knowledge is so limited that controversy can hardly be said to have begun; but it would seem to suggest that the various tumour forms assumed by tissues under the malignant process do not differ so essentially as we are apt to believe when we look at them too narrowly on the histological side.

With regard to the most common early forms of malignant disease, epithelioma and carcinoma, much has been written in recent years; but there is little that can be called new in the recent literature of the pathology, whereas enormous advances have been made during the same time in the therapeutics, especially surgical, of malignant diseases of the uterus. Perhaps, from the pathological point of view, the most important question at the present time is the position of adenoma. Within the last few years much has been added to the literature of this subject, and although there is considerable difference of opinion, the tendency at the present time appears to be to recognise its comparatively frequent occurrence in a malignant form, and to place it in a separate category from carcinoma.

The most recent of all questions with regard to the malignant diseases of the uterus is the character and seat of origin of "*deciduoma malignum*." The subject is comparatively of little importance from the practical standpoint, because of the rare occurrence of cases; but from the point of view of the pathologist few subjects could be more interesting. There can be little doubt that the extraordinary amount of attention which this subject has received, is bound to bring about not only a considerable increase in our knowledge of the changes, both normal and pathological, which occur in the postpartum uterus, but also to add to our knowledge of the development, the normal physiology, and the pathology of the placenta.

In the following pages the names epithelioma, carcinoma, and sarcoma are used in the ordinarily accepted sense—the two former indicating a malignant new growth of epithelial origin, the last implying a malignant neoplasm of connective tissue origin. Other names, such as "*adenoma malignum*" and "*deciduoma malignum*," may be accepted provisionally as implying certain characteristics to be discussed in dealing with them in their proper place. Whether they should be retained in our nomenclature is a question which can be settled only when discussion and observation have produced something like unanimity of opinion concerning the origin and structure of the tumours, and the course and symptoms of the ailments resulting from their growth.

The classification of the malignant diseases of the uterus which will be adopted here as most suitable to the present state of our knowledge, and as most convenient for exposition, is the following:—I. Epithelioma et carcinoma portionis vaginalis uteri; II. Carcinoma cervicis uteri; III. Carcinoma corporis uteri; IV. Sarcoma corporis et cervicis uteri; V. Adenoma malignum (corporis et cervicis uteri); VI. Decidua malignum. The varieties or subdivisions of each form will be described and discussed in their proper places.

**I. Cancer of the Vaginal Portion of the Uterus.**—*Pathological Anatomy.*—The pathological anatomy of cancer of the vaginal portion and cervix forms a very difficult and extensive chapter in any exposition of malignant disease of the uterus. The mass of published observations, both clinical and histological, is so enormous, and the views of pathologists who have devoted much attention to the subject are so diverse and even contradictory, that at first sight it is difficult to detect any sort of order in the chaos. When we remember, too, the great amount of controversy which has taken place on almost every detail of published observation, and the impossibility for each author or expositor, for the time being, absolutely to divest himself of some preconceived opinion or bias, we may readily conclude that the easiest, and perhaps the best course is to rest satisfied with endeavouring to record concisely the state of knowledge and opinion at the time of writing.

The vast mass of observation and opinion previously on record has been greatly increased within recent years, when the bulk of the profession in Europe and America has declared so steadily in favour of extirpation in the treatment of malignant disease of the uterus. Not only has exact clinical and macroscopic observation become more confident, exact, and practically useful, but the material obtained for the histologist and pathologist in comparatively early stages of the disease by operation and post-mortem examination, has become vastly more various and interesting, as well as incomparably greater in amount. To the same cause also we owe the fact, all important for the practical application of the pathological knowledge acquired, that clinical observation and histological investigation have become more closely associated. As an illustration of the industry with which observations are made and published, it may be mentioned that the last three volumes of the *Jahresbericht über die Fortschritte auf dem Gebiete der Geburtshülfe und Gynäkologie*, ending with 1894, contains references to 528 contributions on the malignant diseases of the female sexual organs alone. We may ask whether progress in the acquisition of exact knowledge of the pathology of uterine cancer has been great in proportion to the facility of obtaining material and associating the observations with the history of individual cases; and whether the progress of pathological knowledge has corresponded with greater precision of diagnosis and treatment by the practical gynæcologist? On this point, it must be confessed, there is much

reason to answer with hesitation. Even the most recent text-books or manuals of gynæcology show strongly the influence of authority in their pathology, for their authors, after critical analysis of the statements and opinions expressed in the reports of the earlier observations, implicitly admit that they must accept them as final and complete. And yet there is a good deal in what appears as description of personal observations which must have contained an important element of inference; and it may be alleged without undue rashness that some conclusions offered by the pathologists, and given practical effect to by the gynæcologists, have not been justified by the exact clinical observations of recent years. We may safely assert that the expectations founded by practical men upon the earlier investigations into the origin of cancer of the cervix have been doomed to disappointment; that no light has been thrown by the labours of the pathologists upon the etiology of cancer of the cervix, and that little guidance has been obtained in the treatment of the disease. Still we have hope for the future, and all careful observations, however remote from obvious practical ends, must be welcomed and studied. Any statement, however concise, of the views of the inquirers into the histology of early cancer which may be assumed to be necessary to completeness in the exposition of the subject, can hardly be made clear and independently readable without a short summary of the normal minute anatomy of the parts.

For the present purpose we must keep in mind that the cervix uteri consists of (i.) a vaginal portion, and (ii.) a supravaginal portion extending to the isthmus, where it joins the corpus uteri. The vaginal portion projects as a dome or truncated cone from the vaginal vault, and is, when normal, firm and resistant to the touch, and perfectly smooth, hence the terms *os tinæ* or *museau de tanche*. On visual inspection the nulliparous vaginal portion is found in health to be of a pale pink colour; and the appearance of its surface confirms the impression of smoothness given to the sense of touch. It is planted, as it were, in the centre of the vagina, and around it there is an indefinite boundary, where the smooth mucous covering of the vaginal portion gives way to the rougher and harder vaginal lining. The existence of this boundary is, I believe, a point of some interest and importance in the spread of epithelioma of the vaginal portion. The os externum, or opening of the cervical canal, is the most striking feature presented by the vaginal portion. In the perfectly normal nulliparous uterus it may be oval or round; its edges are indicated by the deeper colour of the margin of the cervical mucous lining, which generally can be more or less distinctly seen; and it is situated rather behind than at the centre of the most prominent spot, because of the slightly greater bulk of the anterior lip. The parous or multiparous os externum, when the uterus is in a state of complete involution, may vary considerably within the limits of health. It is seldom free from marks of injury: there are fissures, more or less deep; retention cysts, some of which may have ruptured, give rise to the appearance of small ulcerations; others may have dried or shrivelled up, producing minute



white specks on or just within the apparent margin of the cervical canal. The area of exposure of the red cervical lining is invariably larger in appearance than in the nullipara, chiefly because the os is more open. Deeper fissures or lacerations producing lobulation of the vaginal portion with ectropium, hypersecretion, induration with prominent retention cysts, increase in volume, and other related changes, should be looked upon as pathological conditions. Between this higher limit of deeper coloured lining about the os, and that lower limit where the smooth and soft mucosa shades off into the comparatively hard and rugated vagina, the portio vaginalis has been aptly described by Sir John Williams "as a cup of stratified epithelium, resembling a tailor's thimble, which fits on the lower end of the cervix proper." The layers of epidermis in health conceal the vascular papillæ; but the presence of these is obvious to the naked eye in the early stage of catarrh of the portio, by the scarlatinal appearance of the reddened mucosa from which the epidermis has been partially shed. In health this mucous covering can be felt to glide over the firm muscular mass of the cervix underlying it; and in some diseased conditions it can be readily peeled off, like wet paper, so as to expose the chorion with its torn and bleeding papillary vessels underneath.

Between the vaginal portion with its squamous epithelium, and the true cervical mucous membrane with its cylindrical epithelium and innumerable gland structures, there is a narrow band where the epithelium is transitional, chiefly of a cubical form, and the glands fewer but still numerous. The existence of a debatable border or belt, which may in diseased conditions be invaded from above by glandular or papillary structures resembling carcinoma, or from below by the squamous epithelium of the portio, has been too readily accepted by the gynæcologists from the pathologists. In support of the existence of this variable belt it is said that there is occasionally great difficulty in making out the line of demarcation between the portio vaginalis and cervix. This line is, however, almost certainly much more constant than is so often stated, even when on simple inspection it seems most obscured by the effects of exposure, of injuries, or of a catarrhal process. The cervical portion secretes an alkaline fluid, and the surface of the portio vaginalis is always moist with an acid exudation or secretion. If a piece of litmus paper be laid across the doubtful margin, which has been gently wiped with dry cotton wool, the dividing line will be always found exact and definite; the moisture on the reddened surface of the apparent portio is always acid, that of the area of cervical lining, even when obscured by ulcerating retention cysts or ectropium, is always alkaline. This test may be applied with advantage in an old laceration of the cervix with hypertrophy and flattening out and erosion by contact with the vaginal wall. It is a guide to boundaries, and may show how much has to be done to restore the vaginal portion by operation. With regard to the mucous membrane of the cervix it may be best to quote the following description: it "is much firmer and more fibrous than that of the body.



Between the rugæ of the *arbor vitæ* there are numerous saccular and tubular glands. In the lower part of the cervix the mucous membrane is beset with vascular papillæ, and the epithelium is stratified, but in the upper half or more the epithelium is columnar and ciliated like that of the body. The glands, which are short, with large lumen, are everywhere lined with columnar ciliated epithelium, even where the epithelium of the surface is stratified. Besides the follicular glands there are almost constantly to be seen the so-called *ovula Nabothi*, clear yellowish vesicles of variable size, but visible to the naked eye, embedded in the membrane" (37).

In describing the relevant points in the structure of the parts under consideration, there is one more margin or boundary which should be mentioned as of interest in relation to cancer of the cervix. This is the upper termination of the cervical canal where it is marked off by a constriction, the *os internum*, beyond which the cavity of the body begins. Just below the narrowest point at the junction of the canal of the cervix and of the body there is a narrow band of mucous membrane, which in structure more nearly resembles the mucosa of the body than that of the cervix. Küstner says of this border line that microscopically no difference can be made out between  $\frac{1}{2}$  cm. of the cervical mucous membrane and an equal measure of the corporeal lining immediately adjoining, either as regards the form and arrangement of glands or the form of the cells. Although there is no proof that this portion of the canal undergoes the changes in the structure of the corporeal mucosa which are characteristic of menstruation, its participation in corporeal pathological changes which do not extend to the cervix as a whole is such as to supply important diagnostic features; as, for example, in catarrh of the corporeal endometrium, which produces a tender spot just below the *os internum* while the rest of the endometrium of the cervix is comparatively insensitive. It is just at this narrow circle of tissues in the transition stage between cervix and body that the malignant ulceration spreading from epithelioma of the cervix appears to be arrested to a very great extent, and when checked to extend more rapidly, and to a larger extent, into the muscular substance and the parametrium.

The check to the process of ulceration at this spot, and the irregular hypertrophy from cell proliferation which takes its place, are probably the immediate causes of the pyometra which is so frequently met with in fairly advanced post-climacteric cases; and the obstruction produced by hypertrophy must be a factor in the production of pain as a symptom of advancing cancer of the cervix in younger women.

*Elements of Origin of the Disease.*—The discussion of the ultimate facts in the origin of malignant disease of the portio vaginalis and cervix uteri does not help us much either in theory or practice. The differences of opinion amongst the pathologists are too marked to make it possible for those who have not specially worked at the subject to form an intelligent judgment; and in practice, while there is room for fearing that the plausibility and symmetry of some theories have led to practical

applications not altogether satisfactory, the vast mass of detailed description, and the conclusions drawn from microscopic observations by pathologists are not so far accepted as exact and well-established as to warrant confident practical conclusions on the part of the gynæcologist. Most of the theoretic teaching, moreover, may be looked upon as merely the application of theories of cancer in general to the uterus in particular; it is largely doctrinaire and irrelevant to practical gynæcology.

Whether the ultimate fact be some change occurring in connective-tissue cells alone or in epithelial cells we do not yet know; the decision may have far-reaching consequences in our methods of treatment, but the discussions are not yet drawing to an end. The habit of pathologists in drawing upon embryonic tissue, either persistent in some latent form, or reappearing in adult organs, in forming and supporting hypotheses, appears to the practical man to produce ill-defined shades of opinion not conducive to clearness of comprehension or to practical ends. It is still true, as stated by Gusserow (14), that our comprehension of the anatomy of malignant tumours has been greatly obscured by the multiplicity of observations, and by the discussions on the point of origin of cancerous tumours. So far as I know, Virchow was the author of the theory of the connective-tissue origin of carcinoma of the cervix, and with the name of Waldeyer we associate the opposing view that previously existing epithelium is the starting-point. Both theories recognise the epithelial character of cancerous growths, whether we call them carcinoma or epithelioma. Klebs supports the theory of the epithelial origin of malignant disease of the cervix. The transitional or cubical epithelium just within the os externum begins to proliferate, penetrates into the stroma of the mucous membrane, and even into the underlying muscular tissue, and causes occlusion or destruction of blood-vessels, and consequent necrosis and loss of substance within the vaginal portion and cervix. The squamous epithelium of the portio vaginalis, especially the cells of the rete Malpighii, becomes the seat of papillary hypertrophy; there is in the same way invasion of the subjacent structures, and consequent necrosis and breaking down. Thus originate the cancerous ulcers and papillary growths of the vaginal portion. With regard to carcinoma of the cervix, Klebs maintains that it is also of direct epithelial, not of connective-tissue origin, as was formerly believed. The starting-point is in the epithelium of constricted cervical glands; and he assumes a tendency of the *ovula Nabothi* in the vicinity of the internal os to undergo cancerous changes.

Ruge and Veit, whose work has received so much attention, maintain that the pavement epithelium of the portio is never the point of origin of epithelioma or cancer of the vaginal portion; not even of the "cauliflower excrescence." The starting-point is either in the deeper connective tissue or in the newly formed glands found in their follicular and papillary "erosions." Hence the seat of origin of this cancerous growth is outside the os externum, and it does not extend towards the cervix; its development is towards the vagina and parametrium — a con-

clusion carrying serious practical results. The connective tissue stroma becomes vascularised and passes into the embryonic condition, and the new cellules assume an epithelioid aspect. Exceptionally, these authors have seen adenomatous vegetations of glandular epithelium origin give rise to carcinoma; but they never saw plugs of epithelium extending down into the connective tissue. So, symmetrically as it were, it is the connective tissue of the walls of the cervix, or of the glands of the mucous membrane, which is the point of origin of carcinoma of the cervix. They assert that this is the origin of a form of malignant disease of the cervix which does not extend downwards outside the os externum, but spreads all round, destroying the cervical tissues and extending readily upwards to the body of the uterus.

It would be useless to multiply opinions on this subject. There is a certain element of controversy, as well as the record of observations in the literature, which has some resemblance to the discussion at present in progress concerning the point of origin and nature of "Deciduoma malignum." But Ruge and Veit's investigations and results have such a captivating conciseness and symmetry about them, that they were widely accepted, and have almost held the field ever since. Their influence on gynæcology was perhaps best illustrated by the work of Schroeder, who might almost be considered their exponent in practice; and his influence is still seen in the advocacy of certain ineffective methods of surgical treatment of cancer of the vaginal portion. Connective-tissue origin suggests connective-tissue relations, hence probably the theory of early invasion of the parametrium by cancer of the vaginal portion, and consequent discouragement of the radical operations.

*Seat of Origin of Growth in its earliest Clinical Aspect.* — From the investigations and hypotheses already mentioned it would be easy to infer, in anticipation of clinical observation, that there must be three positions in the anatomical sense in which the earliest appearance of cancer of the portio and cervix may be made out: (i.) As small nodules deep in the tissues of the vaginal portion with the squamous epithelium still unbroken. This view follows the hypothesis of Ruge and Veit as to the deep-seated, connective-tissue origin even of papillary growths, although such growths apparently arise from the squamous epithelial surface of the portio vaginalis. (ii.) As a shallow ulcer on the surface of the vaginal portion, a feature due to the origin of the new growth in the most superficial part of the connective tissue under the pavement epithelium or in the "erosion," follicular or otherwise, which in structure is a new growth, and is capable, according to the hypothesis, of assuming malignant characters. The process thus originating attacks by preference only the surface of the vaginal portion, and extends towards the vagina; never upwards through the os externum. (iii.) As a nodule or nodules within the os externum, and underlying the mucous membrane, through which the minute malignant growth ultimately penetrates, producing necrosis. This form is the clinical result of the malignant process which starts in the connective tissue of the walls of the cervix just under the mucosa,



and it spreads readily along the cervical canal, but not downwards beyond the os externum.

This is all so plain and obvious that the student might be disposed to conclude that the pathology of cancer of the vaginal portion and cervix is one of the simplest chapters in gynæcology; whereas, in fact, there are few subjects of which the details are more complicated and more exasperating; more elusive of all attempts to grasp and co-ordinate them. To complete the theoretical study it would be desirable to obtain some cases, beyond cavil or reasonable dispute, so early in their development as to stamp them as of the squamous-celled portio, of the "erosion," or of the cervical mucosa. The cases referred to in Ruge and Veit's earliest work are not, however, much more conclusive than the later observations of Abel and Landau on the corporeal endometrium. Chronic endometritic tissue changes were found by them, on microscopic examination of the uterus removed by vaginal hysterectomy on account of epithelioma of the cervix, to be sarcomatous in character; a conclusion proved to be erroneous by subsequent observers.

During the last sixteen years I have endeavoured to examine cancer cases with some precision and, keeping these theoretic opinions in mind as they were published, I have sought for early cases even when symptoms did not suggest the presence of malignant disease; but I have never seen a case of flat ulcer, of papillary growth of the portio vaginalis, or of carcinoma of the cervix, in which the os externum was not involved. Some of the cases have been in the earliest clinical stage, with only a very small amount of friable material outside or inside the os uteri; and in all such cases the appearances on examination pointed to the margin of the os externum — the belt of transitional epithelium — as the site of origin of the growth. It is quite true that Sir John Williams, in his monograph on *Cancer of the Uterus*, states a widely different opinion on the same ground of clinical observation. He says: "On looking through these cases, we find that cancer may begin at any point of the vaginal portion from the os uteri to the vaginal vault. It may begin at more than one point — at several close together — as in the first case, or it may originate at the external orifice as in the second and third cases, or it may commence from the surface of a polypus growing from the lip — it may begin, in fact, on any point of the cervix covered with stratified epithelium." Holding the opinion which he has expressed, that the cancerous process always involves the os externum, the present writer must submit that Sir John Williams' description of his material does not bear out his conclusions. For fear of being mistaken or appearing unfair, he has frequently gone over the points of the eight cases described; in only one case was the os uteri uninvaded, and that case, it may reasonably be objected, would be better described as one of primary epithelioma of the vagina due to the prolonged irritation and "insult" of thirteen years of prolapse. Is not the histology as described also that of primary cancer of the vagina?

From what has been said, it will be inferred that my conclusion



is that the distinction usually maintained between cancer of the portio and of the cervix is an arbitrary one, and one not supported by the facts of cases in actual practice.

Among others Leopold maintained the same opinion. In a discussion on the diagnosis of cancer of the body of the uterus, he supported the theory of Waldeyer, Thiersch, and others, that cancer can only be defined as an atypical epithelial neoplasm; and he endeavoured to prove that to separate cancer of the portio from that of the cervix is not in accordance with the facts, and is indeed impossible. "Carcinoma of the uterus occurs most frequently below the os internum, commencing in the epithelium of the portio vaginalis; seldom in that of the mucous membrane of the cervix. A large number of cases of so-called carcinoma of the cervix are really cases of carcinoma of the portio vaginalis."

*Modes of Extension of the Malignant Growth.*—Without trenching upon the ground that must be gone over in dealing with the course and symptoms of the disease, it may be well here to consider shortly the modes, including directions, in which the disease spreads in its later initial stages, and the forms which it assumes.

Epithelioma of the portio vaginalis, when it takes the form of flat canceroid or ulcer, spreads impartially upwards and downwards. The shallow ulceration downwards is most apparent comparatively early, because the lip affected long retains its shape, however it may change in size and in colour; but any firm manipulation of the affected cervical area, such as the application of a sharp curette, at once reveals the extent of the invasion. I have before me microscopic preparations of tissue taken from the clear-cut margin of a shallow epitheliomatous ulcer where it had just reached the vaginal vault in front. There is healthy tissue at one end of the section, and cancerous tissue at the other. The surface of the ulcer was clean looking, and the whole process seemed superficial, but the cervical canal was excavated into a wide crater, and the whole uterus was fixed by infiltration of the parametrium. The same processes are often seen in still earlier stages in the same relative advancement; it is purely a question of stage in the progress of the disease. The superficial ulcer which destroys the surface of the portio vaginalis, the area of soft squamous epithelium, does not seem readily to invade the region of the more cornified epidermis of the vagina. The tissues encountered at the line of transition of the epithelium seem to exercise a certain retarding influence.

At the external os the process of necrosis, as a rule, destroys the mucous lining rapidly, and penetrates more or less profoundly the muscular tissue of the vaginal portion, although the muscular tissue offers greater resistance to invasion than does the mucosa. But beyond the os externum the mucous membrane disappears at a more rapid rate than the muscular and fibrous tissue arranged round the os, and consequently, even comparatively late, there may be a relative narrowness and firmness of the parts representing the original os externum. The process of ulceration continues, creating a sort of funnel-shaped cavity in place of

the normal cervical canal, and ultimately reaches the neighbourhood of the os internum. Here, again, there is a comparative arrest of the process of necrosis, only more marked than that which is found at the junction of the vaginal portion and vagina, or even at the external os. In not a few cases the resistance to the ulcerative process is so great that considerable hypertrophy both of epithelial and parenchymatous elements may result. This hypertrophy in post-climacteric cases sometimes produces a complete closure of the os internum, bringing about the condition of hydrometra which, probably by bacterial invasion, ultimately becomes pyometra; by no means a rare complication of post-climacteric cancer of the cervix.

In the papillary form of epithelioma of the vaginal portion the disease begins on the margin of the external os. The earliest development of the tumour which ever came under my notice was that of a small growth with the characters of cauliflower excrescence. It was growing from the margin of the os externum, and the cervical tissue itself did not appear to be invaded. Considering all the circumstances of the case, the operation of total extirpation was recommended and performed, and it was found on incision at the external os that the cervical tissue was invaded nearly symmetrically all round, and the uterus, as a museum specimen at the present time, shows a distinct funnel-shaped excavation where the soft papillary growth originally existed. It is alleged in several manuals and monographs which I have consulted, that the papillary form of epithelioma does not readily invade the tissues of the cervix uteri, but causes early infiltration of the parametric connective tissue. The first time that I witnessed an operation upon a uterus affected with cauliflower growth was in the Vienna Hospital, over twenty years ago, when Carl Braun operated by means of the galvanic cautery. In that case an opening was made into Douglas' space; and since then I have more than once had the same experience of opening Douglas' space on making the first rapid incisions with suitable scissors for the removal of the mass of cauliflower growth as the first step in extirpation of the uterus. Such an experience implies that more than the vaginal portion of the uterus was invaded by the cancerous growth during the formation of the cauliflower mass which filled the vagina, and in each case, on completion of the operation, it was found that the amputation had been made a little way below the internal os. In every case of cauliflower excrescence, even when the mass in the vagina was enormously large, the uterus itself was found to be movable, and extirpation was considered feasible. So far, then, as the spread of the disease is concerned, in a case of papillary epithelioma it may be confidently alleged that invasion of the cervix is early and constant, and that infiltration of the parametric connective tissue cones comparatively late.

When invasion of the parametric tissue does occur in cancer of the vaginal portion or cervix, the areas first affected are almost invariably in the sacro-uterine folds; not in the broad ligaments, as one sees so

often asserted. It is wonderful how distinctly the extent of this invasion may be made out in the examination of a doubtful case. When considerable ulceration has occurred, and especially if there have been early infection of the uterus with saprogenetic organisms which produce an offensive odour, no decision as to operation or prognosis should be given without a careful exploration of the pelvis per rectum. This can only be done efficiently after the bowels have been properly prepared, and the patient has been put under an anæsthetic. It is then possible to make out with marvellous distinctness the position and size of the various parts of the uterus and its relations; and if the slightest infiltration have occurred in a sacro-uterine fold or anywhere else, it can hardly be missed. The condition of one or other fold—and it is always one or other in such a case, never both—is often that of a curved line of irregular nodules. These swellings are rightly assumed to be produced by glandular infiltration and enlargements. Repeatedly, in operating in rather advanced cases, I have gouged out of the parametric tissues small infiltrated glands, like the smallest of those that we are familiar with in dissecting the axilla in the operation for mammary cancer. It is the gradual development of this invasion of the sacro-uterine folds, more than any other individual facts in the case, which brings about fixation of the uterus.

The clinical form of the disease at a comparatively early stage, sometimes called mushroom growth, arises from hypertrophy of the parenchyma of the cervix with softening owing to infiltration of cancerous elements. It is almost always a carcinoma of the cervix uteri, and its site of origin is within the os externum. It marks a stage of the development of the new growth at which the uterus is almost invariably movable.

The later stages of the progress of the vaginal portion or cervix may be more suitably taken under the symptoms and progress of the disease than in treating of the pathological anatomy.

*Etiology.*—To know the causes of things is said to be the chief aim of philosophy; and as applied to medicine in no portion of the field has greater industry and intellectual effort been expended with less satisfactory returns than in endeavouring to get at the causes of malignant disease of the uterus. The object sought for has been some clue to the intimate nature of cancer with a view to prevention and rational treatment. This is a pursuit for the general pathologist, not for a specialist in diseases of women, but there are well-ascertained facts with regard to malignant disease as it affects the female sex which give the study of the etiology a special interest to the gynaecologist.

First, as to frequency of occurrence, malignant disease affects the uterus in a very large proportion of all the cases observed; and to this preference is due the fact, well established by statistics, that women are much more liable to cancer than men.

Such statistics are easily available for reference, and need not be quoted in detail. The older compilations of figures may be found in



Gusserow's classical work on the *New Growths of the Uterus*, and some others will be referred to in the sequel. Statistics proved before Simpson's work that in England, between thirty and forty years ago, about twice as many women as men died of cancer. Simpson showed that malignant disease was about equal in the sexes at or about the age of fifteen; and from this period of life the difference became more marked until between the ages of 45 and 55, when the proportion of women to men affected was as  $3\frac{1}{2}$  to 1; and then it began to approach a more equal distribution.

When we come to the particulars of sex and organ attacked, we find that cancer of the uterus takes the most conspicuous place. Schroeder found that of 19,666 women who died of cancer, 6548 were affected with carcinoma of the uterus.

For the Paris hospitals the figures as given by Picot lead to much the same conclusion with regard to the proportion of men and women affected; and Picot brings out the fact that in 100 cases of cancer 51 were malignant disease of the uterus or mamma, and that there were more than three times as many cases of the former as of the latter.

Similar results were brought out by E. Wagner on investigation of the post-mortem examinations in Vienna, Prague, and Leipzig.

In this country, more recently, Sir Spencer Wells again analysed the statistics and obtained results, as compared with Simpson's, which suggested an increase in the frequency of malignant disease, with a still higher ratio of women to men. Leaving aside these general results from the examination of vast numbers (32) of cases, we must look to details for assistance. Oskar Müller analysed in great detail 577 cases of cancer of the uterus which were observed at Gusserow's clinic, and brought out some very striking facts which suggest more definite conclusions.

A defect observable in all these analyses, one which greatly lessens their value when looked to for practical hints, is the grouping together of all forms of malignant disease of the uterus. But, so far as causation is concerned, cancer of the portio vaginalis and cervix may be looked upon as a disease quite distinct from carcinoma of the body of the uterus, or sarcoma in either body or cervix. Carcinoma of the body is a comparatively rare disease found under conditions strikingly different from epithelioma of the portio. It may be put down for the present at about 2 to 3 per cent of all cases of carcinoma of the uterus. The proportion of cases of sarcoma is at present an unknown quantity. The cases are practically included in the figures for cancer of the body, and therefore they amount to a fraction of the 3 per cent.

Taking the figures which have been compiled as we find them, and applying a logical method of induction by looking for some constant point of agreement amidst the bewildering differences presented in the analysis of a large number of cases, we are struck with the agreement within limits as to the age of the patients. The great majority are women past the middle period of their sexual life, if that be reckoned as from 15 to 45, and many are beyond it—past the menopause. Gusserow puts together the figures of certain writers, whom he mentions,



and reaches a total of 3385 cases of cancer of the uterus. Of these women only two were under 20 years of age; and we may fairly assume that these were cases of sarcoma. Of the whole, 1169 cases occurred between 40 and 50, and 856 between 50 and 60. When we make allowance for the fact that the number of living women rapidly decreases from decade to decade of their age, we see that the number of cases between 40 and 60 forms a very large fraction of the whole.

Oskar Müller found, in the 577 cases which formed the subject material of his contribution, more than one-third of the patients were under 40 years of age, and in no case was the age under 20.

In 100 consecutive cases in the out-patient department of the Manchester Southern Hospital I find 77 cases sufficiently detailed to be safe for reference: of these 1 was under 30, 23 were between 30 and 40, 28 between 40 and 50, 21 between 50 and 60, and 4 between 60 and 70. There was no case over 70.

Of the 54 in-patients admitted to the Cancer Hospital connected with Owens College since its opening, 2 were under 30, 11 between 30 and 40, 28 between 40 and 50, 11 between 50 and 60, 1 between 60 and 70, and 1 over 70. There was only 1 case of cancer of the body among these, and one case of sarcoma of the uterus.

We may consider the influence of age as completely demonstrated: 50 years is the age at or about which the climax is reached. Age suggests lowered vitality and tendency to degeneration, but speculations in this direction have led to nothing. The deteriorated vitality of the tissues is common to all women of the same age whether cancer is to appear or not.

Narrowing down from age to race, we find a suggestive fact. It may be considered as proved beyond doubt that cancer of the uterus is much less common among the negro races, and even among Asiatics, than it is among the white races. This fact seems to imply that persons more highly organised intellectually and morally are rather subject to this scourge than those who are more callous or less intellectual or imaginative.

If we now come within still narrower limits, from race to class, we meet with a still more striking fact. All observers are agreed that cancer of the uterus (without distinguishing the cervix, which would make the exceptions still fewer) is most frequently met with in the lower ranks of the people of all countries. So marked is the difference of incidence, that it might be reasonably affirmed that if we could place all the lower orders who suffer from privation and depressing environment for a generation or two in the position of the more favoured we should stamp out cancer. In his analysis of 577 cases Oskar Müller found that the patients were almost exclusively of the labouring class. My experience is that cancer of the portio and cervix occurs only among the working classes; the apparent exceptions are so few that they are hardly worth discussing. This remark applies to private as well as to hospital patients.

Keeping in view age and class, we proceed still further to eliminate irrelevant points, and we find that child-bearing has some relationship to the causes of cancer of the portio and cervix. Nulliparous women are almost immune. Winckel (56) puts his experience on this point very concisely: "The large majority of women with uterine cancer are married. Of my patients only 1·7 per cent were unmarried, and two-thirds of these had given birth to one or more children."

In the analysis of 100 consecutive malignant cases occurring in my hospital practice there is only one unmarried woman (aged 52), and she was suffering from sarcoma. Seventy women, of whose cases the record is sufficiently full for the present purpose, had borne 412 children, and had lost of these 219. The total number of abortions of the 70 was 68. Thus the average number of children was 5·8, and the average loss by death in their families was 3·1. The average of abortion was nearly one for each. One woman had borne eight times, and when she came under treatment, at the age of 38, she had only one child left. Another had borne six, and had aborted twice: she came under treatment at the age of 40, and she had then only three left. Another had given birth to seventeen living children, and at 43 she had seven remaining. One had a record of thirteen children and two abortions; at 40 she had only four living. One had been the mother of three, and at 35, when she underwent the operation of total extirpation, she had none. Other examples are: at the age of 42, ten children, six living, no abortions; at 45, eleven children, seven living, no abortions; at 40, seven children, four living, two abortions; at 45, ten children, four living, no abortions; at 48, seven children, one living, five abortions; at 58, nine children, three living, three abortions; and so on. On the other hand, there is one woman of 33, with all her children living, five in number; one of 52 with her family of eight all living; and another of 47 with her three children still living. There was not a barren woman amongst them. These illustrative details as to loss of children are given here to obviate repetition; they will be discussed hereafter.

The highest proportion of nulliparæ affected with cancer of the uterus which I have seen mentioned is that found by Oskar Müller; namely, 5·3 per cent. The number of cases of cancer of the body of the uterus is not deducted.

When we follow such suggestions as possible causal relations between cancer of the uterus and constitution, temperament, occupation, previous illnesses not connected with infection or traumatism of the sexual organs, anomalies of menstruation, sexual excess, and such like, we can find no trace of a constant factor.

What then about heredity, which has taken such hold upon the popular imagination? In reference to cancer of the uterus it appears to be a factor of little etiological importance. In Oskar Müller's analysis of Gusserow's later cases it hardly appears. Gusserow collected 1203 cases, including his earlier material, and found only 90, or 7·8 per cent,

in which cancer might have been produced, among other causes, by hereditary tendency. Picot found a hereditary predisposition in 13 per cent of cancer of all organs. But it should be remembered that to trace heredity among the class of women usually affected with cancer is a difficult process. Genealogy is not a strong feature in the acquirements of their class; it is often very difficult to get with precision the most elementary facts in the history of the individual patient herself. Heredity, at any rate, has not been shown to be an important factor in the production of cancer of the uterus.

Setting aside irrelevant and questionable evidence as to causation, we find some striking points which are fairly constant: (i.) The race, one highly developed, although the class attacked does not consist of the highest specimens of their race; (ii.) the social class whose lives are the most laborious, monotonous, and careworn of their community; (iii.) the domestic relationships of marriage and maternity; and (iv.), age, a certain limited period of the individual life. The age is that of the decay or extinction of the functional activity of the sexual organs, and of diminishing vitality of the tissues in general. The domestic circumstances and the class of the sufferers imply a vast amount of unhappy experience of life.

On the physical side there is the constant drain on the constitution of frequent pregnancy and lactation, sometimes both combined at the same time; for many of these women go on suckling their children partly for the sake of economy, partly because they believe lactation prevents conception. Parturition means injury to the cervix uteri, and not unfrequently still further drains upon their strength by puerperal illness. There is to be included almost invariably, also, irritation and consequent discharges from the injured cervix and vaginal portion of chronically filthy genitals. In addition there is the loss of rest from nursing sick children, and the constant clamour of those who are well. Many of the women of the class under consideration live laborious lives in doing domestic work, or as the breadwinners of ailing, lazy, or dissipated husbands. We must also keep in mind the chronic deficiency of nourishing food and of suitable clothing, and that many live under the most insanitary conditions of their own making, which no local authority can avert. Too frequently, also, bodily exhaustion and mental depression lead to the use of bad alcoholic stimulants, and when food is not plentiful the line of excess is easily reached. Alcohol under such conditions produces a chronic metritis which is quite characteristic.

On the mental side there is constant care as to pecuniary means, worries from interrupted employment, anxieties from the illnesses of husband and children, and grief from frequent fatal termination of illness in both young and old. Eighteen per cent of the cases to which I have referred as illustrating loss of children were widows. Add to all this the constant monotony of the lives of such women; the lives of the men are by comparison interesting and free from care.

But, it may be asked, What has all this to do with cancer of the



cervix uteri? The relation to physical and mental depression, combined with local lesions, is not very remote. With some effects of emotional conditions upon the uterus we are quite familiar. We know that violent emotions produce interruptions of pregnancy, and many illustrations of minor injuries directly due to violent emotion might be quoted if space permitted. It stands to reason, therefore, that the griefs and smaller depressing emotions—from bereavement by death to domestic quarrels and insults—by which the women suffer, and on which they brood without alleviating distractions, may in time produce serious results by a sort of integration of the effects of emotional storms comparatively frequent and therefore little noted.

Coming to more definite details as to factors modifying nutrition, we have also to note the chronic irritation from lacerations of the cervix and chronic cervical catarrh. *Ubi stimulus, ibi fluxus*. Many gynæcologists have said that they have never obtained any evidence of a causal relation between laceration of the cervix and epithelioma. But have they not looked too much to the fissure and the cicatrix? A cervix that has been deeply lacerated undergoes very gradual changes, which show that the irritation exists not in the cicatrix, but in the whole of the vaginal portion; and the coincidence of epithelioma and “multiparous os” is too frequent to be explained as mere chance.

There is also a suspicious frequency of coincidence of malignant disease of the cervix and a history of gonorrhœal infection. Bumm has made a statement with which all gynæcologists who have paid special attention to the subject of gonorrhœa in women must agree. “The chief seat of gonorrhœa in the woman is the urethra and the cervix uteri; the infection of the cervix produces symptoms and distress only at the beginning; when it has once become chronic it may continue for years without causing trouble (Beschwerden).” Winckel (56) may also be quoted from among many authors who have given expression to a similar opinion: “It seems plausible that such specific diseases (gonorrhœal infection) favour the development of carcinoma.” There is also an emotional side to this possible factor in the causation of cancer. When working at gonorrhœal infection in women, my experience was that a hospital patient suffering from post-nuptial infection had, nearly always, to bear also the domestic trouble of a lazy, useless, or dissipated husband. When questioned as to the husband’s occupation the answer came with remarkable frequency that he was out of work. The cruelty of conveying infection was not at all likely to be an isolated injurious act in the domestic history of such people.

The conclusion which the facts seem to lead up to is that cancer of the vaginal portion and cervix is very largely a *morbus miserie*. What the import of the apparent exceptions may be I do not profess to understand, but it seems probable that if the conclusion be in the main true, the exceptions when understood will support the law. While heredity in the individual is obscure or apparently feebly expressed, there may be in the exceptions the expression of the hereditary suffer-



ings of the class; the comparatively well-cared-for individual of her generation requiring comparatively little of a determining cause to bring out that which might have appeared in the former generation, but for the absence of the final determining local cause.

The hypothesis of *morbus miserice* places cancer of the cervix in the same category as leprosy; and by analogy we may assume that cancer may be banished by social ameliorations which will raise the presently existing cancer-producing class to the higher level of the presently existing immune, just as the disappearance of the horrors in the individual lives and environment of past generations has made leprosy in England an historic disease.

*The Symptoms and Clinical Course.*—In the early stage of cancer of the vaginal portion there are no symptoms which could indicate to the person affected the presence of a grave disease. There is nothing to interfere in the slightest degree with the ordinary course of life; and even if the woman's attention be attracted to certain trifling symptoms, her fears are not excited; thus it is very rarely indeed that the physician has the opportunity of observing a case from the earliest onset even of the symptoms. The chief symptoms, in the order in which they appear before their relations are obscured by the appearance of important complications, are hæmorrhage, a more or less offensive vaginal discharge, and pain. The hæmorrhage comes from the portion of the cervix uteri affected, that is to say, almost always from the free vaginal surface at the margin of the portio. It is seldom profuse. It appears rather as an irregular slight hæmorrhagic discharge from the genitals than as the immediate result of traumatism. The injury may be produced by straining in constipation, by sexual intercourse, or by some other cause implying direct interference with the part affected. In the married, hæmorrhage *post-coitum* is perhaps the most constant and suggestive ante-climacteric sign. The stimulus to the uterus resulting from the presence of the new growth may be such as to produce a noticeable increase in the amount or duration of menstruation, but this is not by any means a constant feature at any stage of the disease, and its extent has been probably much exaggerated. Before the ulceration and infiltration have so far advanced as to make pain a noteworthy symptom, a small vessel may occasionally give way, producing a smart attack of hæmorrhage; but the occurrence of any considerable or alarming hæmorrhage, either by sudden profuse discharge or by prolonged slight metrostaxis, is not an ordinary feature of the early stage of malignant disease of the uterus.

In women who have passed the change of life hæmorrhage is still the first symptom of the disease; but then it usually attracts more attention, and leads, upon the whole, to an earlier demand for medical advice: yet still the tendency is to waste time. However far advanced in years, the patient is apt at first to be satisfied in her own mind that menstruation has recurred; and there is a deep-rooted conviction that any discharge of the nature of menstruation is beneficial. Post-

climacteric pudendal hæmorrhage should always suggest malignant disease.

At or about the menopause the hæmorrhage is attributed at first to a supposed irregularity, or even flooding, characteristic of the change of life, and not implying any pathological departure from the ordinary health.

Somewhat later in the course of the disease hæmorrhage may become profuse, and it occasionally continues in a slighter degree for weeks without intermission; contributing largely to that condition which we call the cancerous cachexia.

The foul discharge is the second characteristic symptom of early malignant disease of the cervix. The discharge is at first entirely or comparatively inodorous. This is specially the case in the profuse discharge from the cauliflower excrescence before the growth has been interfered with in any way, either in the digital examination of the physician, or in the use of a syringe manipulated by the patient herself. The discharge from the cauliflower excrescence, even in the early stage, is profuse; but it is comparatively thick and slimy: it is neither serous nor mattery. In the earliest stage of all it contains numerous white particles, portions of the rapidly growing and necrosing epithelial elements. In the case of a superficially ulcerating epithelioma, or in the early stage of cancer of the cervix, the discharge is scanty, thin, and serous; but it soon assumes its characteristic turbid, dirty water, and repellent appearance, and its extremely offensive odour. As a rule it is a profuse discharge before it becomes a foul discharge. The discoloration of the discharge arises, no doubt, from minute extravasations of blood, the elements of which become darkened and disintegrated in the serous fluid, and under the chemical and bacterial influences at work. The offensive odour is produced by the changes which the serous fluid undergoes in oozing from the necrosing surfaces, owing to the access of air and external filth, and to the invasion of saprogenetic organisms. The modes of infection by these organisms are numerous and obvious. There is always the possibility of an autogenetic infection, as it has been called, by bacteria previously existing in the vagina; and in the disease under consideration there is always easy access of infecting material from the external genitals, inasmuch as it is a disease of multiparæ, in whom the vulva and vagina are as a rule flabby, readily gaping on movement in a recumbent position, especially on the side. There can be little question also, that all manipulations, even those undertaken with antiseptics in order to cleanse the parts, are capable of producing injuries of the affected tissue, slight hæmorrhages, and even saprogenetic inoculation.

When a serous offensive discharge has once been set up, it is permanent; and however the hæmorrhage, or pain, or other symptoms may be modified by treatment, the foul discharge, except on total extirpation, persists to the end. It may be modified for a time by antiseptics, by curetting and other direct treatment, but it is never wholly removed.

Pain, as a symptom of malignant disease of the portio vaginalis or

cervix uteri, comes on comparatively late; and cases are met with in which the whole course of the disease is run without the pain being so severe as to call for the administration of sedative drugs. It may be set down as a rule that when the patient at the first interview mentions pain as a prominent symptom, we may expect to find, on physical examination, that the disease is well advanced, and that the uterus is fixed, or at least in such a condition as to make thorough surgical treatment impossible or useless.

It has been so frequently observed that when there is rapid necrosis of the vaginal portion producing an open cavity the pain is slight, that we might almost generalise to the extent of saying that pain is in inverse ratio to the amount of ulceration.

When the vaginal portion alone is affected there is no pain. The onset of pain appears to coincide with the invasion of the parametrium, and consequent interference with the mobility of the uterus. The extension of the cancerous parametritis ultimately causes pain of a different kind by pressure on nerve trunks. This is the origin of the distressing aching in the groins, thighs, and down the legs, which is usually the first painful symptom complained of.

When the ulceration reaches the vicinity of the os internum, or somewhat earlier when the case is one of the hard form of cancer of the cervix, we hear of a genuine uterine pain. It is the dull aching in the sacral region which now becomes persistent. It may have been complained of earlier as comparatively slight at the time when fixation of the uterus was beginning. When pain is hypogastric and spasmodic at times there is reason to suspect occlusion of the internal os and the formation of pyometra. This is probably the explanation of the intermittent or colic-like character ascribed to the pain in some cases. It applies only to post-climacteric cases; in younger women the extension of the disease so as to interfere with the lumen of the internal os, or to produce rigidity of tissues in its neighbourhood, must obviously produce a characteristic discomfort amounting at the menstrual periods to intense suffering. To pressure of infiltration upon uterine nerve, and destruction of nerve tissue by ulceration, must reasonably be attributed a part of the constant pain referred both to the sacral and the hypogastric regions.

Later still in the history of the case an element in the pain is interference with the bladder and bowel, or other organ to which the sense of pain is referred. And among the local causes of suffering we find sometimes, though not so frequently as might be expected, an irritation about the vulva from dermatitis or pruritus produced by the discharge.

If the patient live sufficiently long there is added to her sufferings a constant dull, depressing pain from the extension of the disease to the peritoneum. The peritonitis is rarely acute, and the pain is often brought out only by palpation in the course of examination or treatment. It is a perimetritis, and it seldom extends beyond the pelvis except as

a final lesion due to some accident or rupture which makes it general and rapidly fatal.

Perhaps the explanation of the low form of the peritonitis and its comparative painlessness is that it is always a late complication. The patient is then both anæmic and sapræmic, and from this physical condition arises largely the characteristic hebetude and apathy. Besides, the uterus at this stage has been long fixed by the infiltration which also interferes with the ureters, and the resulting uræmia must add its contribution to the production of anæsthesia.

By the time pain has come on and the uterus is fixed we find another symptom which, in my experience, is constant; this is nocturnal rise of temperature. The temperature may be normal or subnormal in the morning, but it rises to 100° or a little higher at night; and later in the course of the disease there may be sudden temporary elevations to a much greater degree. The causes appear to be — (i.) the parametritis, and in this respect it is much as we find it in a chronic inflammation of the circumuterine tissue without abscess formation; and (ii.) a certain amount of sapræmia from absorption at the seat of ulceration. When much loose necrosed tissue prevents the free flow of the serous discharge, if this friable substance be removed by the sharp curette, and a moderately strong solution of zinc chloride be applied by means of a tampon of lint packed into the cavity, the temperature falls for a few days if there be not much cellulitis; but when the uterus is involved in a pelvic mass, the operation produces little or no impression upon the temperature. The septic temperature can be removed temporarily with its cause; the parametritic temperature remains constant.

The absence of symptoms produced by sepsis, even of pyrexia, is remarkable, considering the foulness of the ulcerating cavity. It depends, in all probability, upon the fact that in the invasion of the tissues a stratum of non-infective infiltration precedes even the deepest layer which saprogenetic bacteria have reached; and by this advanced stratum both blood-vessels and lymphatics are rendered more or less incapable of taking up and conveying the soluble poison. Hence also, perhaps, the comparative rarity of metastasis from uterine cancer. The freedom with which the fluid products of necrosis of uterine tissues can escape no doubt also contributes to the same result.

Among the more general symptoms of cancer of the uterus must be mentioned the effects of the disease upon the digestive organs, which are almost constant. The most striking fact in this group of symptoms is the early occurrence of anorexia in almost every case of the disease; how it arises has not been explained. It is obviously not from any direct effect upon the intestines. Later in the progress of the disease it may be associated to some extent with the sapræmia which exists during ulceration, even if the retention of débris and fluid be slight; it certainly is not caused by the anæmia, which comes later in consequence of the serous discharges and hæmorrhage. At a more advanced stage we find that changes affecting the digestive organs occur as the result of pressure;



this is when the disease has made such progress as to produce a certain amount of pelvic peritonitis, or constipation, by the mere mechanical pressure of the enlarged uterus or mass of parametritic exudation upon the rectum or the lower part of the sigmoid flexure. In this interference with the functions of the intestines there are rarely any symptoms approaching in severity those which mark the tendency to obstruction, as observed in cancer of the bowel itself, or in pressure of the mass of tumour on the rectum in pelvic hæmatocele. There is a certain amount of pressure and a certain amount of paresis; and these factors alone, combined with the loss of flesh, produce a total result which is fairly characteristic; there are abdominal tumidity and softness, and we may even watch the peristaltic action almost as clearly as in obstruction of the bowel, partial or complete, from intestinal cancer.

Vomiting may occur comparatively early, long before a mechanical cause for it exists. It is not, however, a constant symptom until an advanced stage of the disease. In early anorexia it may be produced by injudiciously zealous feeding to keep up the strength; by unsuitable food and medicines, or as the result of idiosyncrasy. Vomiting is an important factor in these cases, but not an important symptom.

Another member of this group of symptoms is irregular diarrhœa. As a consequence of the bowel irritation produced by the development of the disease, we occasionally find, not extreme constipation or partial obstruction, but painful attacks, with frequent mucous motions, lasting for several days, and amounting to diarrhœa. Diarrhœa is a symptom which we find at some stage of several diseases primarily affecting the internal female sexual organs, and involving loss of tone of the muscular tissue of the lower bowel. Such is occasionally the case late in perimetritis, for example, and in other conditions besides cancer. We frequently find this symptom as a result of inflammation in pelvic abscess; not in the early stage of the parametritis, but in the chronic stage, when an abscess exists, and is burrowing towards the intestine, and causing a certain amount of pressure on it with softening of its tissues. In such a condition of the intestine, when it is to a certain extent softened, inflammation of the lining is indicated by the occurrence of comparatively small and frequent motions, containing a large amount of serum and mucus. In the course of cancer of the uterus there is an analogous condition, producing a similar form of diarrhœa which, however, is less constant and continuous.

With regard to the urinary organs the symptoms in the earlier stages are not appreciable, whereas in the later stages much distress is almost a constant element in the case. In the early stage of cancer we may be unable to discover any bladder symptoms at all; later, when circum-uterine structures are breaking down, the ulceration spreads towards the bladder more frequently than towards the bowel. Long before the septum between the utero-vaginal canal and the bladder is broken down, there is cancerous cellulitis affecting the loose tissue between the uterus and bladder, and causing irritability of the bladder and frequent micturition. Later still, on making a careful examination in such a case, with

the aid of a bladder sound, we find a suggestion of irregularity and hardening of the mucous lining of the bladder itself. Invasion is now sufficiently far advanced to produce vesical catarrh. Yet this is not the principal urinary trouble associated with cancer of the uterus. The principal trouble affecting the urinary organs arises from interference with the ureter, not with the bladder itself directly, or with the urethra. As the cancerous parametritis extends outwards in the broad ligament, the uterus becomes fixed. Owing to the position of the ureters they are very liable to be subjected to pressure. The disease at first may be unilateral, or it may spread almost equally on both sides, and consequently the pressure may be on one ureter or both. Now the ureter in this cancerous infiltration is not displaced, as it may become during the growth of a fibro-myomatous tumour. The ureter may be greatly displaced by the benign tumour, yet no marked symptom of kidney disease be produced. In the course of the cancerous infiltration the ureter is embedded, not pushed aside; the infiltration becomes harder, and the calibre of the ureter is encroached upon. This constriction of the ureter leads to dilatation of the tube higher up, and results in hydronephrosis, pyonephrosis, atrophy, or some other of those changes which go on in a kidney the ureter of which is obstructed. The symptoms accompanying these serious changes may be comparatively slight; or there may be signs of marked uræmia. Sometimes when the patient may appear to be in danger from the uræmic condition alone, sudden relief may be obtained by rupture of the ureter into the ulcerating cavity of the uterus and the establishment of a fistula. Such a method of relief, however, is not an incident to be counted upon, but it may be produced by operation, and has occasionally been done. If symptoms of uræmia once come on, we may, with confidence, conclude that the prognosis as to length of life is extremely gloomy; and it becomes worse the harder and more nodular and fixed the mass around the uterus has become. This is a point of the very greatest importance in dealing with advanced cases of cancer of the uterus, and specially with regard to prognosis. When we find, on examining a patient, that there is a hard nodular fixed mass, without much ulceration; when we learn that there are irregular hæmorrhages, comparatively small in amount; and we find only a small cavity, or no cavity at all, we may be disposed to count on producing considerable amelioration by treatment. There is usually in such cases a considerable amount of pain, but we can relieve pain; and inexperience may lead us to take a hopeful view of the case seeing that there is no considerable danger from hæmorrhage. In such cases, if we overlook the signs of kidney complications, we may give a favourable prognosis as to length of life, and yet find that the patient suddenly dies, or rapidly sinks in a very short time after we have pronounced the prospect of life to be good.

When those hard, nodular, non-ulcerating masses are found filling the pelvis, one or other kidney may be found distinctly enlarged, giving perhaps the impression of being cystic. This is all the more easily made out, because of the emaciation characteristic of this advanced stage

of the disease. This enlargement should be always looked for in the first examination of a case.

Dilatation of the ureters, till they look like loops of small intestine, is by no means a rare condition, as shown by post-mortem examination in uræmic cases, and in cases of veiled uræmia.

Much stress is purposely laid here on this feature of the late stage of cancer, as so little guidance is to be found in text-books, and the condition of the urinary organs is of the first importance in regard to prognosis. Late in the course of the disease we may find, as the result of the ulceration, fistula between the bladder and the ulcerating utero-vaginal cavity; this is an inevitable result of the cancerous process if the patient live long enough. We may find recto-vaginal, or recto-uterine fistula, which is a much rarer condition of parts than the vesico-vaginal fistula; or both anterior and posterior fistulas may be established, producing the condition of cloaca. By this time the patient is in a very miserable state owing to pain and the impossibility of preventing discharges, foul smells, and irritation.

Long before this time the "cancerous cachexia" has become established. The hæmorrhage, foul and profuse discharge, pelvic pain, irritability of the bladder, loathing of food, and slight sapræmic and inflammatory feverishness, bring about a change in the patient's appearance which is quite characteristic. It is marked by loss of flesh, a peculiar unwholesomeness or yellowish pallor of the whole skin, loss of colour of the lips and even of the tongue, occasional puffiness about the eyelids, habitual want of animation, or even an expression of depression of spirits, and an indescribable air produced by want of rest and constant physical suffering. If there be an element of uræmia in the case there are superadded the special symptoms which it produces in its slighter and slowly developing forms; chiefly hebetude, drowsiness, and impairment of vision.

The final stage of cancer of the uterus does not present any new or important symptom. The patient is past the stage of profuse hæmorrhage. She is anæmic, uræmic, and sapræmic, emaciated, and, apart from quality, the quantity of blood in the body has become comparatively small. Owing to this fact, and the weakness that affects the heart as well as every other organ, occurrence of severe hæmorrhage is rare, although exceptionally it may be the immediate cause of death from ulceration through the walls of a considerable artery.

Owing to the increase of the cancerous mass, we may find signs of pressure upon the blood-vessels in the pelvis, just as we find pressure upon the ureters. There may be some œdema of one or both limbs. There may also be pressure on the sacral nerves, producing distressing aches or cramps in one or other of the lower extremities. Later still we may occasionally discover thrombosis, which is a comparatively rare condition, because few of the patients live to the time at which it comes on. If we find persistent local areas of œdema, local areas of pain, with change of colour about the inside of the thigh, or about the groin, indi-



ating that thrombosis or phlebitis has occurred, then we may feel assured that the patient has not long to live.

Now these conditions, symptoms, and local changes, occurring in the various parts, have been described in sequence; but they develop, of course, more or less simultaneously. In this advanced state the patient, as a rule, is constantly in pain; in the back, in the groins and thighs, and in the hypogastrium. It is a question whether there is any nocturnal exacerbation of the pain in the advanced stage when there is a fixed mass in the pelvis. If such patients do not receive soothing medicines their pain impresses itself more upon them in the sleepless and silent hours of the night, but there is no proof from exact clinical observation that severe painful exacerbations occur regularly in the night or at other definite times like the maximum and minimum of the barometer.

It is not often that we meet with cases which have run their course without medical or surgical interference. Such cases, however, are on record, and illustrate the natural history of ulcerating epithelioma originating in the vaginal portion. The symptoms may attract so little attention throughout that medical advice may not be sought until the end.

*Causes of Death from Cancer of the Uterus.* — Supposing we have to do with an advanced case, we must consider what facts would lead us to anticipate an early fatal termination. In what direction will the complications appear which will lead to the inevitable end? In a large number of cases there seems to be no special direction. The patient dies from marasmus, from want of nutrition of the tissues, and consequent loss of power of the whole organisation — of the muscles, heart, organs of respiration, and nervous system. We may call it merely loss of strength, or by the more pedantic name of asthenia. Occasionally, owing to some complication, we find peritonitis spreading from the uterus to the pelvis generally, and even beyond it; causing pain and further depression of the heart's action. It may also be accompanied by diarrhœa, which precedes the fatal termination. Occasionally, in advanced cases, we find that the disease spreads to the Fallopian tubes, causing a cancerous form of pyosalpinx; just as we find in some cases that obstruction of the os internum with bacterial infection produces the cancerous form of pyometra. From the tubes the inflammatory process may spread to the ovaries and peritoneum. But general peritonitis, from some sudden giving way of protective adhesions, or bursting of an abscess of the tube or ovary arising from cancer, is of very rare occurrence.

(Edema of the lungs, heart failure, ascites, are local indications of extreme loss of strength. But the commonest of all the complications arises from the interference with the functions of the kidneys by pressure upon the ureters, though uræmic convulsions are comparatively rare. Occasionally, but very seldom, sudden hæmorrhage is the immediate cause of death. Sometimes women who have not been recently bleeding to any alarming extent, but who are greatly reduced by all the causes that have been already enumerated, suddenly have an attack of hæmorrhage. In their general condition they cannot stand much further



loss, and a sudden gush of hæmorrhage, owing to ulceration through some vessel even of comparatively small size, causes syncope, and the patient thus suddenly dies. If a tampon were immediately applied the hæmorrhage might be stopped; but, as a rule, in the sort of case under consideration skilled assistance is not at hand, and the hæmorrhage is the final episode in the story. This termination, however, may be considered to be comparatively rare. Of the cases that I have had under my care, I can remember only two or three in which hæmorrhage was the immediate cause of death.

*Duration of the Disease.* — With this subject of the causes of death comes the question as to the duration of life in any given case of cancer. This is a question which we are always asked when the diagnosis has been finally established; and it is one that, with the evidence which is available, we can seldom answer in a manner satisfactory to ourselves. Extreme periods have been set down as the duration of cancer; but there are no two cases alike, and any application of averages becomes misleading. The patients, as a rule, are not greatly dissimilar in certain respects. By the time the first symptoms of cancer show themselves, the vast majority of them are in comparatively poor health, and if they belong to the same class socially, they have gone through similar experiences of life. But the phenomena of the disease may widely differ. In some cases, especially in the comparatively young, the disease spreads rapidly; in some cases, especially in the more elderly, it has a very slow development indeed. By the time the doctor is consulted the disease has almost invariably made considerable progress, and it is seldom possible to learn with exactitude when the disease began. We can, therefore, only guess from the symptoms at the probable duration of life in the individual case. We may find a case of infected uterus with considerable ulceration in the cavity; and yet we may confidently say the patient has a fair prospect of living two or three years. The tendency in our predictions is to exaggerate the rate of progress which the disease will make, and therefore to make statements minimising the patient's prospect of life. But if we take the case of a patient who is not suffering pain, and whose uterus is not fixed, we may say that the condition is the most favourable to continuance of life. And yet we are all very liable to make mistakes. By seeing the case only two or three times at intervals one can hardly forecast its future progress. In a recent post-climacteric case, at the time of the first consultation, the doctor in attendance had not made an examination for several weeks previously; at that date he was not quite certain of the diagnosis, but thought there was a suspicious nodule on the vaginal portion at the os; slight hæmorrhage had also occurred, and had recurred a few days before we saw the patient together. On our visit, on the posterior lip including the os, there was a distinct, small, ulcerated nodule. The patient was sixty years old, and had enjoyed good health. Total extirpation of the uterus without delay was recommended, but the patient's objections were not overcome for more than six weeks. No further

examination was made until the patient was on the operating table, and when the parts were exposed an amazing development was found: the small nodule had become a great ulcerating mass; the whole of the vaginal portion was distinctly involved, and owing to vaginitis by contact posteriorly, it was necessary to begin unusually low down in the vagina in order to remove all suspected parts. In such a case as this, when an elderly woman with a comparatively small nodule first mentioned the slight hæmorrhage, one might have been disposed to regard the case as a favourable one, and to estimate the prospect of life at two or three years or more.

When we meet with a patient on whose face the cancerous cachexia is impressed, whose symptoms date back for many months, whose uterus is fixed and ulcerating, and about whom there is a haunting fœtor, however slight, we can only look for a short and downward course. We may say that the patient will live a year, but we know that a considerable portion of the time in this last stage will be really passed in intolerable suffering, only to be relieved by the judicious application of a process of euthanasia. In such cases, too, we must always look for embarrassment of the kidneys, and keep in mind that there may be a rapid or sudden termination in uræmic convulsions, or in hebetude deepening into coma which may be their equivalent.

**II. Cancer of the Cervix.** — After what has been already said, the consideration of cancer of the cervix, in the narrower sense, need not detain us long, if we direct our attention strictly to carcinoma cervicis uteri, and not to those forms of malignant disease which are often described as such, but which are certainly, or almost certainly, cancer beginning in the circle of the os externum. Such cases should, strictly speaking, be regarded as forms of cancer of the portio vaginalis.

Cancer of the cervix, in the restricted sense indicated, occurs in two well-marked forms. In the first of these, if in a comparatively early and clearly distinguishable stage, the patient mentions symptoms which suggest malignant disease. There is the characteristic form of hæmorrhage, and there is a tolerably profuse and suspicious discharge which may or may not have become offensive. Offensiveness of the discharge depends upon bacterial infection; and the cervix is protected from infection in the early stage of the disease in the same way as cancer occurring in the cavity of the body, but in a less degree. It is the proliferation of epithelium, the consequent reaction in the tissues with congestion and profuse discharge from the cervical glands, and finally ulceration which bring about the characteristic thin, sanious, or dirty water discharge from the affected area. Most pathologists, and clinicians who pay special regard to pathology, are agreed that the disease originates in the deeper cells of the cervical glands; not more superficially. Sir John Williams, for example, on this subject says: "The starting-point of cancer of the cervix is, in so far as I have seen, the cervical glands. I have seen no clear instance in which the disease originated in the epithelium of the

surface." This conclusion may be accepted as a representative statement of the opinions of the most competent clinical observers.

As the disease advances, the destruction of tissue proceeds upwards towards the os internum, and in this class of case it sometimes invades and passes beyond the internal os. At an equal rate, as a rule, it passes downwards, chiefly destroying the mucous lining, and invading more or less the parenchyma of the cervix. In the supposed example seen before destruction of the vaginal portion is greatly advanced, the cervix will be found enlarged, but not usually to a very marked degree. The os externum may be more or less patulous, probably plugged by unhealthy looking slime, mixed with turbid or sanious serum; and the first impression on inspection through the speculum is that the case is one of marked erosion. There is a ring of eroded mucous lining extending more or less widely round the external os. But in the cases of which we can speak with confidence, there is something both in the colour of this eroded area and in the appearance of the discharge that suggests malignancy. The tissues are not found hard, irregular, or nodular on the first digital examination. It is the patient's appearance which, taken with the symptoms, excites suspicion. If in such a case the sound be used, it will give the impression of touching abnormally soft and probably irregularly distributed tissues; and if, on suspicion being roused, a suitable sharp curette be passed through the internal os and tried upon the cervical tissue, this will be found soft and flabby, and there will be no difficulty in obtaining shreds, or rather plugs for examination.

In some cases further advanced, where the ring of the os is still more or less intact, the curette may break down a portion of the tissues surrounding the os uteri, and expose a cavity filled with friable necrosed cervical material. At this stage there is still no invasion of parametric connective tissue; and, consequently, the case is in the most favourable condition for total extirpation.

The second form is comparatively rare, but there are points in it of great interest from the surgeon's point of view. It may be called the *scirrhous form* of cervical cancer.

An ordinary case, as met with in practice when the disease has sufficiently advanced to make the subject of it seek for medical relief, presents on vaginal examination a hard, irregular vaginal portion, suggesting that peculiar cartilaginous hardness which is often found towards the menopause in a woman who has suffered for many years from chronic cervical catarrh. Digital examination also usually reveals the fact that the uterus is movable, or the movements are only slightly embarrassed. The first step in physical examination probably also proves that no hæmorrhage is produced by touch, and that there is little discharge. Pain is the symptom which has led the patient to seek advice; hence, probably, the reason why such cases are seen in a comparatively early stage of the disease. The patient has usually passed the menopause, and for years has been free from symptoms referable to the pelvis.



On examination with the speculum, it is found that the external os uteri is comparatively little involved. There is probably a hard, unwholesome, and shallow excavation at some point occupying a portion of the circumference of the part. All that is visible of the rest of the uterus may appear comparatively anæmic; there are usually, in fact, merely indications of senile changes. Investigation into the condition of the cervix with the probe or sound produces only slight hæmorrhage. If for the purpose of this inspection the vaginal portion be seized with a volsella, it will be found then that the movement of the uterus downwards is much the same as in the later stage of convalescence in perimetritis. Movement is only slightly diminished. The sound may be passed through the cervical canal, which will be found narrow and irregular. In the cases in which I have succeeded in extirpating the uterus the body has been found uninvaded and senile. This variety of malignant disease of the uterus is the only one which, at the early stage, may suggest an exception to the conclusiveness of the evidence produced by the sharp curette. It requires firm pressure with the instrument to break through the surface of the hard ulcer.

On further examination of a characteristic case, there may be found some indications of invasion of the one or other sacro-uterine fold; but in spite of this, the gynæcologist will probably be strongly tempted to pronounce the case suitable for extirpation and he may confide to his colleague, the general practitioner, that the operation will be comparatively easy. If he proceeds to operation he will find the directly opposite to be true. The most striking characteristic of this form of malignancy is a comparatively early invasion of the connective tissue, both laterally and between the uterus and bladder. There may even be adhesions of the intestine in Douglas's space; and in the course of operation extreme difficulty is consequently experienced in reaching the peritoneum either in front or behind. If the surgeon do succeed in extirpating the uterus, it need hardly be said that he may anticipate a comparatively early recurrence.

When the parts removed are examined after extirpation, the cervix presents comparatively little hypertrophy, with generally hard tissues, and occasionally with harder nodules distributed throughout. In no case have I seen any indication of softening. The pain probably arises from the early invasion of the circumcervical connective tissue, and the hardening of the cervical parenchyma. In one such case which occurred several years ago, the operation took over two hours, chiefly owing to the firmness of the cellular tissue between the cervix and bladder, and on the posterior surface of the uterus between the vagina and the peritoneum of Douglas. During the operation the bladder wall was so thinned that a fistula soon afterwards formed and gave rise to great distress.

I have recently seen another case on which I operated two years and seven months ago. Owing to difficulties from the causes indicated, I had to rest satisfied with amputation at the internal os, and the use of pressure forceps in the left broad ligament, which presented unexpected difficulties.



It seems that after convalescence the patient went on for two years without a symptom, and then she was attended by a doctor for several weeks, owing to an attack of phlebitis in the left leg after unusual exertion during a holiday tour. She complained of nothing further until quite recently, when she again called in the doctor on account of some discomfort in the groins and some increase in the amount of discharge. This was only a few days before my visit. When we saw the patient together, her chief complaint was of two large tender masses of glandular swelling in the groins. She complained of no abdominal pain, and she said but for the painful swellings she would have been "knocking about." On further examination there was found a mass filling the pelvis, but capable of comparatively free, elastic movement. There was no ulceration nor appearance of unequal consistency in the mass. A prominent feature, however, was a large, comparatively soft nodule on the vaginal surface of the urethra, with a considerable area of infiltration of the vaginal wall around it. This soft nodule is almost certainly a fresh centre of development of cancer, with a proportion and arrangement of its constituent elements entirely different from the original disease; and from this cancerous area doubtless comes the glandular invasion.

*Diagnosis.*—The diagnosis of cancer of the uterus must be established, as in most cases of disease, by the anamnesis, and by physical examination. In an ordinary case of cancer of the portio or cervix, in which the disease is so far advanced as to rouse the patient's anxiety by the persistence of certain symptoms, the diagnosis of cancer is among the easiest of case-problems with which the practitioner has to deal. There is the history of irregular vaginal hæmorrhage, if there be nothing else. An irregular vaginal hæmorrhage should always lead to physical examination without delay. On making a vaginal examination in such a case, even when the disease is not sufficiently advanced to produce fixation of the uterus, the diagnosis can usually be settled by palpation alone. There is either a hypertrophic, hard, irregular nodular condition of the vaginal portion of the uterus, which is friable and readily bleeds under the exploring finger, or there is more or less of an excavation with hard, irregular edges. This condition may affect either lip of the cervix uteri; in cases of old and deep laceration of the cervix it invariably at first affects one or other lip. At this stage the disease seldom, if ever, invades the cicatrix at the apex of the laceration. In the cases in which the disease is further advanced, there is more or less of fixation of the uterus with excavation; seldom, perhaps never, does the uterus become fixed whilst the disease is in a stage of mere hypertrophy with ulceration of the vaginal portion, or even in fairly advanced cases of cauliflower excrescence. Palpation of cauliflower excrescence settles the question of malignancy without any further question of physical exploration. In the comparatively early stage, should palpation not settle the question in the mind of the practitioner, the speculum must be brought to his aid. It is only in the cases of flat canceroid or early ulceration that any additional information essential for diagnosis can be

gained by visual inspection. The ability to distinguish between the worst case of cervical catarrh produced by laceration with ectropium, and complicated with ulcerating cervical glands, and the earlier stage of possibly malignant disease, implies a familiarity with the various phases of non-malignant disease of the vaginal portion of the uterus. The malignant condition, however early, always presents an appearance of "unwholesomeness" which is never seen in the extremest form of non-malignant change. Speaking of a case in this early stage, Sir John Williams says of the affected portion, "It was not hard, it was not unduly red, it bled slightly on digital examination, it did not enlarge, and yet it looked vicious." In such a case the tissue would be friable. There is a discoloration, especially about the edges of the area of invasion, usually a darker shade, which can no more be described than can a smell, but which is never seen in non-malignant lesions. It is not possible to lay too much stress upon the need for diagnosis at this early stage of malignant disease: the life of the patient depends upon correctness of early diagnosis. It is quite true that temporising is permissible to some extent; delay may be best to scarify the surface and the edges, in order to open retention cysts, and then to apply, for a few days in succession, some medicated preparation of glycerine which will not discolour, inflame, or otherwise greatly change the appearance of the suspected surface. Pure glycerine is a suitable dressing for diagnostic purposes. After much manipulation or scarification glycerine with a small proportion of tannic acid, or of carbolic acid, or of both combined, is perhaps a better agent for the purpose. If, after a few days of such an application the trifling superficial wounds do not present a healthy appearance, the case may be looked upon as gravely suspicious. But in this early stage, for diagnostic purposes, the great feature of malignant disease, as compared with any other possible disease, is the *friability* of the affected tissue. This fact impressed me many years ago, and for a long time I have depended largely upon it, as I consider it to be a pathognomonic indication of the presence or the absence of malignant disease in the earliest possible stage. The method of diagnosis resulting from this great fact of friability is one which every general practitioner may apply in order to establish a *prima facie* case. This friability is indicated by the readiness with which the volsella tears through when there is considerable infiltration of the malignant elements; and, in the less advanced cases, by the facility with which one can fill the sharp spoon by a clearly cut out portion of tissue.

If a mortal disease which is local in its earliest stages is permitted to become generalised, there must be something very defective in our knowledge, convictions, and practice. There is at the present time a tolerable consensus of opinion that cancer, affecting the cervix uteri, can, in its early stages, be successfully dealt with as a local disease. All specialists in gynæcology, who have turned their attention to the operative treatment of cancer of the uterus, lament the smallness

of the number of cases that come into their hands at a sufficiently early stage to give them a reasonable hope that the operation of extirpation will be followed by a full measure of success. Of such common occurrence is cancer of the uterus that cases are continually coming into the hands of all general practitioners; and it is on their promptness in recognising the nature of the disease, and in dealing with it in the most efficient manner at present known to us, that our hopes of any considerable improvement in practice must rest. Most of the difficulties in the way of obtaining more satisfactory results in the surgical treatment of uterine cancer arise from the circumstances under which the disease occurs, and its early symptoms.

For the prompt and efficient treatment of the cases which come under our observation in the early and favourable stage, we must largely depend upon a definite and easily applicable method of diagnosis. Cancer of the cervix uteri in the ulcerative stage has such marked characters, and is consequently diagnosed so easily, that delay in applying to it the radical surgical treatment, if it has not already passed beyond the point at which such treatment can be of service, is, with our present available knowledge, altogether unjustifiable. There is, however, a still earlier stage of the disease which occasionally comes under the observation of the practitioner, the most hopeful stage from the point of view of surgical interference, which is too often allowed to pass because of doubt as to the significance of the facts observed and consequent feebleness in action. Any method of diagnosis depending upon features which are to be looked for in any given case, and when observed, accepted as sufficient to justify action, must be generally available, and easy of application by the general practitioner. In order to attain the maximum amount of usefulness, such diagnostic signs must be found with comparative ease when looked for, and their verification must not require any processes which demand a large amount of time and care and special knowledge. The chief objection, as a method of diagnosis, to microscopic examination of tissue obtained from a portion of the organ suspected is the difficulty of its application. It requires special knowledge of the methods of obtaining and preparing tissues for microscopic investigation; and even when the practitioner possesses the needful knowledge, the amount of time required for the application of the method greatly diminishes its value. In addition to that, we have to remember that the mere histological examination of tissues can only be looked upon as an auxiliary and complement to the observation of clinical facts, not as a substitute for it. It may be said with confidence, therefore, that the usual advice given in books and clinical lectures, under the head of diagnosis of cancer of the cervix uteri, to make a histological examination of the suspected tissues, is assigning too important a position to a proceeding of more apparent than real usefulness. What we require is an easily applied clinical method of diagnosis, such as will distinguish early cancer from any other condition which a practitioner of average knowledge and intelligence could possibly mistake for it, — a method which gives at the same time a moral certainty, or at least the



very strongest presumption that the diagnosis depending upon it is correct. Such a method of distinguishing between early cancer and other conditions which more or less resemble it, is that of applying the test of friability of tissue which is characteristic of malignant disease.

If in any given case under examination the results obtained by palpation and the closest visual inspection still leave some doubt in the mind of the practitioner whether the condition be early cancer of the cervix, the doubt will, in my opinion, be invariably cleared up by ascertaining the amount of friability of the tissues. The suspected vaginal portion must be thoroughly exposed by a suitable speculum, and the uterus held steady by the volsella. Then with the sharp curette or spoon an attempt is made to scoop out some tissue from the suspected area. If the disease be malignant a definite compact piece of tissue, larger or smaller according to the extent of the infiltration and consequent friableness of the tissue thus operated upon, will be obtained. If the disease be not malignant, a firm rub with the sharp curette will only make the part bleed, and, at the most, some small thin threads or a pellicle of semi-translucent epithelium or of granulations will be detached. The difference is very strikingly brought out by comparing the effects thus produced upon a case of old chronic cervical catarrh, marked by hypertrophy, ectopium, and retention cysts, with the effects produced by similar forcible application of the spoon to the tissues in the early stage of epithelioma. The existence of this contrast, with its easy application to diagnosis, is of the greatest importance in general practice; inasmuch as chronic cervical catarrh, complicated with the other tissue changes just mentioned, is very common, and is almost the only condition at all likely to be mistaken for early epithelioma of the cervix. If we take, for example, two ordinary cases, one of malignant disease, the other of erosion with retention cysts, the characteristic difference does not appear on simple inspection. In the case of malignant disease the ring of the external os may be complete, and the differential diagnosis by simple inspection would have to depend upon a mere shade, an indescribable difference in the colour of the mucous lining, and on some differences in the colour and degree of thinness of the discharge at the os in the respective cases. A comparison between the results to be obtained by palpation does not bring us much further towards the completion of a differential diagnosis. In both cases there may be a certain amount of hardness, unevenness, and irregularity in the consistency of the tissues about the external os; in both there appears to be some hypertrophy of the cervix; but there is nothing, so far as touch is concerned, that would justify us in saying that the one case is malignant and the other is not, and in acting accordingly. Now from certain facts in the clinical history of the malignant case, not in themselves conclusive, the nature of the disease is suspected, and the test of the sharp curette is applied. The instrument cuts through, from inside the os downward to the vaginal surface of the portio, as if through a radish; and although a microscopic examination of the tissues may still be made, the diagnosis may be



considered complete on observing the effects of the curette, taken in conjunction with the other clinical facts, quite independently of the histology. I have found, on extirpation of the uterus in such a case, a condition of considerable ulceration with extensive softening and breaking down of the tissues within the cervix uteri, extending even above the internal os.

Quite recently I had the opportunity of dealing with a case which formed a striking illustration of the application of this method of diagnosis; the clinical history, including hæmorrhage, the appearances, and the impression obtained by palpation supported the diagnosis, already confidently arrived at by a colleague, that the patient was suffering from epithelioma of the cervix uteri. On the posterior lip of the deeply lacerated cervix was a considerable area apparently devoid of epithelium, and with an irregular indurated margin studded with small retention cysts, some of which were ulcerating. The test of the sharp curette was applied with a negative result,—that is to say, the suspected surface was merely made to bleed, and some thin particles of epithelium only were scraped away. A distinct mass of friable uterine tissue was not obtained; nevertheless the appearance of the hypertrophied eroded posterior lip was so suspicious that it seemed as if an exception to the rule had been found, and that the test, as a universal test, had failed. The patient was kept in bed for several days, and medicated tampons were applied in order to cleanse thoroughly, and as far as possible modify the appearance of the suspected area in a healthy direction. The change which took place was of small avail for completing the diagnosis, and the sharp curette test was again applied with the same result. It was, therefore, decided to proceed with Emmet's operation, as the most effective method of dealing with the laceration and hypertrophy; inasmuch as the definite conclusion was reached that the erosion and other changes could not be owing to malignant disease. In performing the operation the incision on one side invaded the margin of the ulcer, and this was followed immediately by a gush of the fluid characteristic of a retention cyst of the cervix, and the hard and apparently hypertrophied posterior lip at once became flaccid and greatly diminished in bulk. This retention cyst of the cervix was the largest that I have ever seen. The operation was completed, the patient made a perfect recovery, and I heard some weeks afterwards from her medical attendant that the symptoms which originally caused alarm had subsided, that the uterus appeared perfectly healthy, and that it was almost impossible to make out the points of union in the ring of the perfectly restored external os.

It would be out of place to illustrate the method or to elaborate the description further. I have applied it myself for about ten years, and have never found it to fail. The suitable application of it presupposes a reasonable amount of knowledge of the diseases of the female sexual organs, and the due consideration and appreciation of all the relevant clinical facts in any given case; when any doubt still remains

in the mind of the practitioner, the effects produced by the sharp curette or spoon should finally settle the diagnosis as to malignancy.

When the operation of vaginal hysterectomy for cancer was being introduced into this country, one of the objections raised by some of the senior gynæcologists to such a serious operation was the extreme difficulty of diagnosing cancer of the cervix sufficiently early. But there never was any such extreme difficulty in diagnosis as used to be alleged; and more exact observation of the injuries done to the cervix in parturition, and of the subsequent and resulting changes in the injured parts which may take years to establish, has done much to minimise or remove any reasonable ground for doubt if it ever existed. It is only in such cases of injury that doubt as to the benign or malignant nature of the changes is excusable. All the other appearances usually enumerated as simulating cancer have only a superficial resemblance to it; ignorance and carelessness are essential to mistaken diagnosis.

The use of the curette in the differential diagnosis of malignant disease of the body of the uterus is better known, but it is perhaps not adopted so generally as it ought to be. Friability is characteristic of the malignant growth here as well; but other friable structures may be found fixed in the body which are only found detached in the course of expulsion in the cervical canal.

English gynæcologists who have given special attention to cancer do not, as a rule, err in depreciating the value in exact diagnosis of clinical work as compared with microscopic examination; but there may sometimes be room for improvement in clearness of statement of the value of each method of diagnosis and of their mutual relationships.

Specialists in diseases of women and pathologists usually assure the general practitioner that the diagnosis of cancer in its earlier stages is not complete without microscopic examination. Such an assertion discourages exact clinical observation, and is equivalent to telling the general practitioner, with comparatively few exceptions, that he is incapable on account of ignorance, or disabled by the exigencies of his professional life, from forming a sufficient diagnosis in a class of cases of frequent occurrence, and in which such serious practical consequences may follow his mistakes. It is, moreover, misleading in that it attaches undue weight to a method of diagnosis which experience proves to be underserving of such implicit confidence.

Sir John Williams, in his work on *Cancer of the Uterus*, says quite truly that clinical observation is, as a rule, not equal to making the distinction between the different kinds of malignant diseases. But he understates the case for clinical observation, when he says that "weeks or months of watching" may be necessary to decide whether a growth be malignant or not; and he overstates it on the other side when he says: "During the early stages of cancer or of other malignant growths, the microscope, I believe, will enable us to recognise and make sure of the disease long before clinical observation."

Mr. Knowsley Thornton, speaking in favour of clinical observation,

called attention to an objection to microscopic examination which is too often overlooked. He said: "To snip out a bit of a malignant growth is in truth to perform a partial operation, and thus to run the risk of rapid spread to distant parts through the opened veins and lymphatics. Clinical observation, if sufficiently close and painstaking, will generally give a distinct diagnosis in good time for successful interference."

On the other hand, Dr. W. S. A. Griffith goes the length of asserting: "In all doubtful cases of disease of the cervix a piece of the suspected part should be cut out, taking care to include the margin of the healthy and affected part, and be carefully preserved and submitted to microscopical examination." Thus implying, we may assume, that the question will be settled; they will be no longer "doubtful cases."

Dr. Herman, speaking on the same subject, says: "I think the value of the microscope in the clinical diagnosis of cancer has been over-estimated. . . . A diagnosis based on the microscopical examination of sections of tissues must be accepted with great reserve."

It may be stated broadly that every German, and almost every Continental gynecologist, supports the opinion of the importance of microscopic examination in diagnosis. Winckel says that "it is evident from the pathology of carcinoma that in its earlier stages the disease can be recognised only by the aid of the microscope. This will reveal the characteristic atypical epithelial proliferation in the tissues, and the consequent destruction of the latter."

Auvard, who is almost an exception, devotes much space to the clinical features in establishing the diagnosis; and he quotes Cornil to show that even with the microscope differential diagnosis may be impossible. "An excised portion of the tumour most frequently permits an experienced eye to arrive at an anatomico-pathological diagnosis; that nevertheless there are cases of malignant adenoma (epitheliom) in which it is difficult to make out any distinction from the structure of simple adenoma."

Gusserow (14), in speaking of the early stage of epithelioma and the difficulty of differentiating from erosion, admits that erosion has been considered by some observers as the initial stage of epithelioma, while Ruge and J. Veit maintained at first that they were the beginnings of true carcinoma. Gusserow, believing that results beyond suspicion could not be obtained from small particles of the diseased tissue, in suspicious cases practised amputation of the entire vaginal portion in order to obtain suitable sections for microscopic diagnosis, even at the risk of now and again operating unnecessarily.

Carl Ruge (41) says: "At the present time it must be the task of the physician to recognise cancer as such in its early stage, and this is possible in very many cases *only* by means of the microscope."

Such opinions are held by men who know that hyperplasia of the uterine mucosa has been mistaken for sarcoma, and that many original papers have been written quite independently in support of the discovery; that the decidua of a *post-abortum* uterus has been diagnosed as sarcoma; that degeneration of the placenta has been found to be like a gumma of



the liver; — mistakes all made by pathologists who were specialists in gynæcology. If this is to be the ultimate position of microscopic diagnosis in gynæcology, then the diagnosis of early cancer, on which so much of success in treatment depends, must in this country remain entirely in the hands of some junior members of the teaching staffs of metropolitan hospitals and provincial medical schools during the otiose portion of their professional lives. And how many of them have had the necessary experience in observing the peculiar character stamped upon malignant disease as it occurs in the uterus? Every man who, at some period of his comparatively youthful career, acquired some distinction in the study of Greek, must remember the ineffable contempt with which in those days he listened to elderly men speaking of the extent to which they had forgotten their classics; and the same man at five-and-forty must in his turn look back with humility or amusement upon their early notions when they find themselves unable to read with ease a verse of the Greek Testament. As with youth and the “*ton-sured head in middle age forlorn*,” so it is with the aforesaid junior teaching members, and even the best educated and most experienced and thoughtful of elderly general practitioners. I have no hesitation in saying that diagnosis by microscopic examination, as far as the general practitioner is concerned into whose hands come the overwhelming majority of cases of early cancer of the uterus, is simply impossible. If you take, for example, the description by Ruge and Veit of the appearances of non-malignant papillary or glandular erosion of the cervix uteri, and their opinions with regard to the appearances of non-malignant compared with malignant changes within the same area, their statements add to our difficulties. They say that there is no clear border line, so far as histology is concerned, between the benign and malignant changes; and it requires a long and concentrated experience, and the special knowledge and acquirements of a professional pathologist who has given much attention to gynæcology, to make out the difference with such clearness and confidence as to guide him to a conclusion on a question implying such serious practical consequences as whether a tissue change in the uterus be benign or malignant. Though strongly impressed, through the experience of many years, with the importance of clinical observation as compared with the microscopic examination of tissues in the diagnosis of cancer of the uterus, as well as in many other diseases of women, I have been afraid of the responsibility of formally expressing opinions in a public and permanent form, which might, however unconsciously, be the mere indication of a prejudice, rather than of a definite induction stated with a practical object. I will confess, also, to a shrinking from the accusation of want of scientific knowledge. All of us do not yet see the greater and the less in some of these matters in their just proportions; and it is as fatal at the present day to the professional character of a man to be accused of being merely a clinician (a thing which it is assumed that any man may be) as compared with being a scientific histologist, for which compara-



tively few men have the opportunities or the peculiar gift, as it is for the moral character of a man to take up a strong position on certain social questions. The motive of one is assumed to be ignorance of pathology; of the other to be sympathy with immorality. Ruminating on this curious fact, and impressed with the importance of calling attention strongly to the need for exact clinical observation of uterine cancer, I came to the conclusion that any expression of opinion from me, even adequate to the strength of my convictions, would be of no avail under present misconceptions as to relative values in professional investigation and practice; and I thought it prudent to appeal to my friend and colleague, Professor Delépine, to describe concisely the shortest possible methods by which the general practitioner could obtain histological evidence sufficient to justify him in coming to a definite decision as to the malignancy or non-malignancy of a disease of the cervix uteri by means of the examination of a portion of tissue excised or curetted from the suspected area. His account of a rapid method of examination may be of use to others besides the brethren who are engaged in general practice.

*Description of the simplest methods which will give trustworthy results in the microscopical examination of tissues of the cervix uteri for diagnostic purposes (Professor S. Delépine).*

“There are two rapid methods which can be used with success. The first consists in freezing the tissues immediately after removal, or within a few hours. The other, a little slower, takes about twenty-four or forty-eight hours, but is much easier to carry through.

“The freezing method consists in taking a small piece of tissue, the most resisting and fibrous looking parts being selected when choice is possible. This piece is dipped into some mucilage of gum arabic, and placed at once on the plate of a freezing microtome. It is partly frozen through. The upper incompletely frozen parts are removed, and then a few sections are cut from those parts which have not yet become too hard. These sections are transferred, one by one, by means of a soft brush, into a dish containing Müller's fluid, or a 2 per cent solution of bichromate of potash. The sections are left in this solution for a few minutes, or even for an hour or two; and then they are spread carefully on a slide. They may be stained on the slide with lithium picrocarmin, and mounted in Farrant's solution; or they may be stained with hæmatoxylin, or hæmatein, and double stained with eosin (weak solutions in spirit diluted with 4 parts of water), or rubin and orange. They can then be mounted in Canada balsam after the usual treatment; namely, dehydration by absolute alcohol and clearing in oil of cloves, both carried out as rapidly as possible. In either case it is well to wash off the Müller's fluid rapidly before using the stains. This method, which has been employed in my laboratories for over ten years, gives good results when the tissues are suitable; but it requires a certain amount of

practice, as the sections when cut fresh have a great tendency to curl or stick together, and also to shrink during the process of mounting.

“The other method, which requires a little longer time, consists in placing small pieces of the tissues to be examined in ordinary methylated spirit. The pieces should not be larger than a small bean, and the quantity of spirit should be at least twenty or thirty times the bulk of the tissues to be hardened. At the end of twelve to twenty-four hours it is already possible to obtain tolerably good sections from such pieces; but it is better, when time allows, to transfer them at the end of that time to absolute alcohol, and to leave them in it for a few hours. On taking the specimens out of the alcohol they are placed in running water for one or two hours; thence they are transferred to mucilage of gum arabic in which they are left for about an hour, or for three or four hours if they are rather soft. Then sections are cut by means of a freezing microtome, the sections being received in water and stained afterwards on a slide, either with picrocarmin or rubin and orange.

“These methods do not give results which can be compared with those obtained by more complete methods of fixing and hardening by perchloride of mercury or chromic acid, and passage through alcohol of increasing strength, but they are quite sufficient for diagnostic purposes. I have lately tried quick hardening by means of the formaldehyde method, and found this method satisfactory; but it does not present any considerable advantages over the slightly longer alcoholic method.”

We need have no hesitation in saying that busy men, almost without exception, will declare that if such proceedings are essential to the early diagnosis of cancer, then most of the cases that come into their hands must remain undiagnosed until more obvious malignant characters have been developed. The history of the case, often so difficult to obtain with preciseness and cleared of irrelevances, and the knowledge acquired by exact physical examination, that is to say, the clinical facts, keeping always in mind the great feature of friability of tissue, are sufficient to establish a *prima facie* conclusion as to the nature of the case to be dealt with. When the clinical test establishes at least a very strong presumption of malignancy any further evidence to be obtained from the histology of the scooped out portion of tissue may be sought for according to the special circumstances of the case. But after the application of the clinical test the chief help will be found in closely watching the changes which take place in the wound, and these are sufficient evidence in every case in which malignant disease of the cervix might possibly occur.

When the other points on which a diagnosis in the early stages may depend are under discussion we still occasionally hear of Spiegelberg's criteria. These were (1) a closer adhesion of the mucous covering of the portio to the parenchyma in the case of malignant disease; and (2) the difficulty of dilating the cervix affected with any cancerous process by means of tents, and the continuance of the hardness after dilatation,

simple induration disappearing under the softening influence of the tents. This opinion has not received much support, although it has been much quoted and discussed. It will probably be considered quite sufficient guidance to their contemporaries to say that Winckel and Gusserow consider the criteria altogether illusory.

When we come to consider the local conditions and appearances which may give rise to suspicion of malignant disease of the vaginal portion or cervix, while the general state of health, which may be deteriorated, does not exclude the possibility of malignancy, the most common case for doubt is that of chronic cervical catarrh, with laceration, ectropium, and extensive "erosion." Still further, if in such a case there be also present chronic retroflexion, resulting from injury in parturition followed by subinvolution, there will be considerable added hypertrophy and other changes of the posterior lip. When the results produced by all those factors are present in the same case the nearest approach to malignant disease which we know of is reached. This is the sort of case in which doubts which are not to be cleared up by rest, temporary medication, scarification, and similar measures, are set at rest by the use of the sharp curette.

The next class of case in order of the frequency with which doubts arise and mistakes are made, is that of necrosis of fibroid polypus with partial expulsion from the external os. Such cases are frequently sent to the specialist for diagnosis, and I have seen a considerable number of them. The most recent was that of a woman in the last stage of anæmia and sapræmia owing to the partial expulsion of an enormous mass of fibromyoma. The process had been going on for many weeks, and the mass had become partially necrosed; it thus permitted the flow through it of a large quantity of serum, which showed externally as a turbid, filthy discharge; malodorous likewise, but not approaching in intensity the smell of the discharge from a cancer in the advanced stage which was thus simulated. Owing to the retraction of the ring of the os the first impression taken from superficial examination of the case was, that a large gangrenous cancer mass represented the uterus, which was itself fixed by infiltration in the pelvis. The character of the discharge and something in the history led to a careful examination under very unfavourable circumstances, and the ring of the external os was discovered. This is the diagnostic feature; the ring of the uterine tissue is found to be intact, homogeneous, and smooth. Cases of this class seldom present more than a momentary difficulty. In all the cases which I have seen it has always been the repulsive appearance of the sloughing mass that has led to the erroneous diagnosis. An inexact clinical history in which symptoms are accepted as occurring in the order in which the patient describes or mentions them, a perfunctory examination of the parts that can be brought into view, and want of attention to differences in the appearance and smell of the discharge, which certainly does not invite close investigation, are sufficient to keep up the supply of cases in which such mistakes in diagnosis are made.

In the more advanced stages of cancer of the cervix the fact that a malignant disease exists is as obvious as in advanced cancer of the breast; or in diffuse ulcerating and offensive epithelioma of the vulva. Occasionally, though rarely, we see malignant ulceration of the cervix with comparatively little discharge and comparatively little discoloration. The margin of the ulceration is as definite to touch and sight as that of a soft venereal ulcer of the labium. In such cases the question always arises, Is the disease malignant or specific? Much library writing has been devoted to the differentiation in such cases between cancer and syphilis. My experience of English practice leads me to the conclusion that syphilitic ulceration of the vaginal portion of the uterus is among the rarest of the diseases of women. I have several times in the earlier years of special work suspected syphilis, and temporised accordingly, in order to see the effects of general and local antisiphilitic treatment; but in not one single case has the ulceration turned out to be other than malignant. There can be no doubt, however, that a real difficulty might arise owing to the extent of ulceration sometimes produced by syphilis in elderly subjects with constitution ruined by other causes as well. The difficulty may be increased by the fact that a history of syphilis is to be found in cases of well-marked and unmistakable epithelioma, with a frequency not to be accounted for by mere coincidence. Winckel says the difficulty is so great in some cases that experienced specialists in venereal diseases have sent patients to him for his opinion. Obviously under such circumstances there is no simple infallible and universally applicable rule. The syphilitic lesions, early and late, do not necessarily involve the os externum — malignant disease always does. The syphilitic ulcer extends towards the os, the malignant ulcer from it — either over the free surface of the vaginal portion, or upwards in the cervical canal. The syphilitic lesion has little tendency to bleed, and is not friable; the malignant lesion differs from it in both these respects.

A detailed history of the case, including the dates of syphilitic manifestations, the appearance of the ulcer when clean, permitting close inspection of the points that make for malignancy or otherwise, and the immediate effects of treatment, should make diagnosis possible even in the most obscure case without much loss of time.

Some Continental writers make much of the difference between papillary malignant disease of the cervix and pointed condyloma. No advantage can result from the accumulation of distinctions and differences of such small account from the practical standpoint. I doubt if any man ever saw a case of condyloma affecting the cervix uteri, for example, in a pregnant woman, in which condylomas were not also obvious in the vagina, on the vulva, perineum, or even in the groins; and if any practitioner, desiring to be pedantically and logically correct in his diagnosis, imagines there could be any question in a case of condyloma as to the nature of the disease, the careful separation of the elements of a papillary condylomatous mass or tuft, and the inspection of the relations of these elements to one another, to the common portion at the



base, and the relation of that base to the intact underlying cutaneous or mucous surface, must set his mind at rest. He will note, moreover, the results of keeping the parts clean with an astringent antiseptic, the effect of cutting away some of the tufts, of the application of nitric acid to a selected spot, and of microscopic examination.

Cases have occurred in which partial retention of products of conception have led to some difficulty in settling the question of malignancy. A shred of placenta, or a plug of decidual tissue sticking in the os externum, has been supposed to be cancer, and conversely. When products of conception are retained, and partly visible through the ring of the os externum, there is something in the colour and consistency of the healthy os all round the ring which is unmistakable. There may be ugly débris, some hæmorrhage, or sanious and evil-smelling discharge; but the suspected substance is free to be lifted away with forceps, and the uterine substance is not irregular to the touch: it is homogeneous, and it is healthy in colour. But the chief aid to differential diagnosis in such a case is a clear detailed clinical history; when such a history is obtained the diagnosis is complete.

*Prognosis.* — The prognosis in cases of cancer of the vaginal portion or cervix uteri cannot now be laid down on the old considerations of the causes of death in such cases, and the probable duration of life while these causes are doing their work without interference.

Prognosis now depends upon what can be done; and what is practicable and beneficial, and what is impracticable and harmful, depends upon the stage of development which the disease has reached, and to some extent upon the special area affected.

We first think of operation. If vaginal hysterectomy is feasible, we estimate the risk to life from the operation, and the possible permanent or temporary immunity from recurrence. These are questions which can be best dealt with under the head of Results of Operation. We have only, therefore, to consider the inoperable cases. We know that here a fatal termination is inevitable, and we must consider whether there are any measures which may appreciably retard the progress of the disease and diminish the sufferings of the patient. By this time the uterus is fixed, or there is such obvious lymphatic infection that extirpation would be useless, even if practicable. We must then consider mainly the following points all brought out under symptoms and clinical course: (i.) Is the disease of long standing according to the data obtainable? If the symptoms can be traced back to a longer than average time, then the progress of the disease is slow; if it is of comparatively recent date, the course is rapid, and the prognosis bad in proportion. (ii.) Is the cancerous cachexia established? If so, then some complication may occur at any time, hæmorrhage, septicæmia, thrombosis, or some other such grave condition with its dangers. (iii.) Are there any indications of embarrassment of the kidneys? If so, an opinion as to the probable length of life of the patient cannot be too guarded. We have no means of ascertaining the exact extent of the changes which are bringing on uræmia. (iv.) The

age of the patient has usually some relation to the rate of growth: the younger the patient the worse the prognosis. To this rule, however, the exceptions are numerous. (v.) Does the patient take nourishment to the average amount in such cases? It is obvious that if no specially threatening complication exist, the fatal end from marasmus must be hastened or delayed according to the patient's power of assimilating food. (vi.) Can the parts be kept in a tolerably aseptic condition? If there be a cavity in the cervix, and if the body of the uterus and the vagina be not involved, the ulceration, and consequently the sapræmia, can be modified. In some cases, owing to descending growths in the vagina, the chief seat of the disease cannot be reached. The success of some of the palliative methods of treatment shows that the progress of the disease can be greatly modified by the use of the curette and antiseptics.

*Treatment of Cancer of the Portio Vaginalis and Cervix Uteri.* — When a disease of the uterus is diagnosed as malignant, the question at once arises: Is it operable or inoperable?

If in a case of cancer of the portio or cervix the uterus is quite movable, and on examination it is found that no considerable invasion of the broad ligament or sacro-uterine folds has occurred, then the treatment in our present state of knowledge is radical operation.

If there is lymphatic infection, and considerable or complete fixation of the uterus, the case belongs to the inoperable class.

Even when the uterus itself is in a condition to make operation otherwise feasible there may be some local complication or some general condition to make the radical operation unjustifiable.

In all operable cases the first question to be answered is whether total extirpation per vaginam be not the best method of treatment.

*Total Extirpation of the Uterus.* — The operation may be undertaken at one or other of two stages in the development of the disease. In the first place, the object sought is the entire ablation of the affected organ, including surrounding portions of vagina and parametrium which show no trace of invasion by the disease. The tissue operated upon must be sound throughout. Such are the cases in which, when the operation is performed at a very early stage, and the patient survives the danger of the surgical procedure, there is ground for confident hope that she is permanently relieved of her troubles.

In the second place, the operation may be undertaken with advantage even if there be some slight interference with the movements of the uterus, and the broad ligaments or sacro-uterine folds can be felt to be more prominent and better defined than in perfect health. In such cases there is some additional difficulty in the early stages of the operation; but the remote results are so satisfactory as not only to justify, but to demand operative treatment. There is little ground for expecting a permanent cure in such cases. The disease will recur at a more or less remote date, but the immediate advantages to the patient, and the diminution in the sufferings of the late stage of the disease, when recurrence has taken place, are such as greatly to outweigh the danger and distress

of operation. These are usually cases in which, owing to delay on the patient's part in seeking medical advice, or owing to want of promptness and precision in diagnosis on the part of the practitioner, the disease has been allowed to make considerable progress. The vaginal portion may have assumed the condition of a large hypertrophic and superficially ulcerating mass; or it may have almost completely disappeared owing to the progress of ulceration within the cervical canal, and yet the uterus may not be completely fixed. There may be obvious indications of deterioration in the patient's general health owing to hæmorrhage and other discharges, and the inability to take sufficient nourishment. The sanious or turbid serous discharge may have become so profuse and offensive as to be a source of distress to the patient; but while the pain is still inconsiderable, and the movements of the uterus are but just appreciably embarrassed, there is every reason to expect a favourable result from radical surgical treatment.

When vaginal extirpation has been decided upon, whatever the modification of the operation, the necessary instruments and appliances are for the most part the same. The patient, after being anæsthetised, is placed in the lithotomy position with the hips projecting over the margin of a suitable operating table. The uterus is, in my experience, best exposed by the use of Auvard's weighted speculum with a comparatively short blade. As the instrument is self-retaining, it releases the hand of an assistant for other purposes, and in this respect it is greatly superior to the short and broad speculum which was formerly, or may be still, in general use in Germany. Whatever measures may have been previously adopted to cleanse and disinfect the parts, it is now advisable to cleanse them thoroughly once more before making any incision or wound. Some operators insist upon the preliminary use of the curette and cautery as essential. The anterior lip of the vaginal portion, where the tissue is healthy, should be seized with a suitable volsella and the movements of the uterus finally tested. The use of the volsella also enables the operator to convey any necessary movements to the projecting vaginal portion so as to permit him thoroughly to cleanse the parts. The cleansing may be very well effected by thoroughly swabbing and rubbing the parts with dossils of cotton wool soaked in a solution of perchloride of mercury of 1 in 2000. Not only the uterus and vagina should be thus thoroughly washed, but all the external parts also, from the mons veneris downwards; special attention being given to the folds of the labia, both minor and major. If there be any friable material about the ulcer or growth of the cervix, such shreds of tissue must be thoroughly disinfected and rubbed away by means of the swabs. It may be even advisable to use the curette, but such a proceeding is seldom necessary. If the disease have assumed the hypertrophic form it may be necessary to begin by rapidly cutting away with scissors sufficient of the new growth to make room for manipulation and to disembarass the proceedings; the bleeding vessels being rapidly seized by suitable pressure forceps. This preliminary step is almost always necessary in dealing with operable cases of cauliflower excrescence. In the majority of cases, however, it is usually practicable,



and, if so, preferable to proceed until the uterine arteries have been ligated, and the vagina and the lower portion of the parametrium cut, before removing any embarrassing mass; as it can then be cut away without any considerable hæmorrhage. Before beginning with scalpel or scissors it is advisable to ascertain the relations of the bladder to the cervix, and this is done by a suitable sound.

There are many modifications of the beginning, and of every separate successive stage of the operation of vaginal hysterectomy. Every operator appears to have a method of his own. In my opinion, it is best to begin with the anterior vaginal wall, just where the vagina is reflected off the vaginal portion, if the tissue be so thoroughly healthy that a margin of normal vagina can be removed with the uterus. The ligatures should be used throughout in order to prevent the loss of blood which results from simple incision, for the patient is usually anæmic. To economise time a special needle may be used for the proper placing of the ligatures. It consists of a strong metal instrument, shaped like an aneurysm needle but without eye, and with a point like a blunt Hagedorn needle. There is a notch for catching the ligature not far from the point on the convexity of the rim. The instrument should be short and strong.

While the uterus is firmly dragged upon by means of a suitable volsella, and held steady by an assistant, the operator passes the needle transversely through a considerable portion of the healthy anterior vaginal wall, so as to occupy as nearly as possible the central third. An assistant puts the loop of suitable silk ligature into the notch of the needle, the needle is drawn back, and the ligature, thus brought through, is tied by the operator. The uncut ends can now be held up by one of the assistants, and the silk acts to some extent as a retractor. The vagina is cut through with scalpel or scissors so as to leave a sufficient button held by the ligature. Care should now be taken to ascertain that the finger nail or the handle of the scalpel can be passed into the cellular tissue between the vagina and uterus. A portion of the vagina should again be taken up on each side in the same way, and cut as before, the separation of the vaginal wall and uterus being carried laterally by breaking down the loose tissue with the index finger, or suitable implement. In patients who are not anæmic a little time is saved by cutting through this portion of vagina, by scalpel or scissors, without previous ligation. The uterus is now drawn sideways — say towards the left — in order to secure the parametrium on the right side, including the uterine vessels. Here it is usually advisable to employ a retractor to prevent the side of the vagina and the labium from obscuring the field of operation. The needle is now passed well down into the parametrium, beginning at the angle of the portion of the vagina already cut, and coming out symmetrically at the corresponding point posteriorly. If care be taken to keep close to the uterus, while at the same time the needle is brought out through sound vaginal tissue posteriorly, then the ligature which has thus been introduced may be tied, and the vagina and parametrium cut through, to the extent of the



tissues ligated, with precision and confidence. The same proceeding is carried out on the opposite side. The uterus in a suitable case may now be dragged much lower, and the complete separation of the cervix from the bladder should be carried out by carefully working with the tip of the index finger from the middle line towards each side. The colour and the firmness of the uterine tissue should not leave the operator in doubt whether he has hit upon the cellular tissue at the proper depth. Before the peritoneum of the vesico-uterine fold is cut through the parts should be thoroughly examined for bleeding points, and all hæmorrhage suppressed by suitable means. It may be necessary to use ligatures or pressure forceps temporarily. It seems to me a preferable rule to open into the peritoneum anteriorly, rather than to cut first into Douglas' space. The anterior fold is easily opened by tearing or cutting at the stage of the operation now reached, and a sponge of suitable size with a piece of silk thread or silver wire attached (so as to prevent it from being lost amongst the intestines), is passed through the opening. It is now time to open Douglas' space. The posterior vaginal wall is ligated and cut through in the same way as before. Whether the anterior vaginal wall be ligated before cutting, or be merely incised, it is always advisable to tie, and then to cut the posterior vaginal wall in sections, or to use pressure forceps, as it is so much more vascular than the anterior wall. The cellular tissue is then broken down as far upward as possible upon the posterior surface of the cervix before tearing through or cutting the peritoneum. The deeper the cellular tissue can be torn before the peritoneum is cut the broader is the future healing surface obtained. An opening is made through the peritoneum and extended laterally, and a sponge is passed through as in front. The uterus is now separated from all the structures around it with the exceptions of portions of the two broad ligaments. This is the stage at which the clamp is put on by those who prefer the clamp. If the uterus be considerably enlarged, it may be necessary to use more than one clamp on each side. When the clamp is secured the broad ligament is cut through on each side, leaving sufficient tissue for the clamp to maintain its hold. Then the uterus is drawn out. When the ligature is used the needle is made to mark off a suitable amount of tissue in the remainder of a broad ligament; the ligature is drawn through and tied firmly, the ends being left long. This is repeated in stages upwards through the whole of the broad ligament and over the Fallopian tube and ovarian ligament; and the same thing is repeated on the opposite side. When the uterus is drawn away the stumps of the broad ligaments are seen on either side, and the sponges are in the middle line retaining the intestines and omentum in the pelvis. The sponges may or may not be renewed, according to the amount of manipulation that has been necessary, and of the hæmorrhage that has occurred; but it is best upon the whole to renew them, so as to ascertain whether hæmorrhage is going on from any point. At this stage in the operation the danger of prolapse of intestine or omentum should always be guarded against. If the patient is allowed to strain from sickness

there is a real danger to life from dislocation of bowel, which may end in obstruction.

The question always arises: Should the ovaries be removed or left? As they are seldom or never infected in any way by the disease, it is not worth while to complicate the operation by removing them unless they force themselves upon the operator's notice by becoming prolapsed. If the patient has passed the menopause the ovaries are shrivelled and atrophic; and if she is comparatively young they soon waste owing to the distal ligation of their arteries.

An important modification has now to be considered. Should the operation be completed by merely packing in iodoform gauze or other suitable material to close the chasm in the pelvic floor, or should the great wound be closed by sutures? From my early experience of the occurrence of dislocation of intestine and consequent fatal obstruction, and of the occurrence of the distressing but not necessarily fatal complication of vesical fistula, I believe it is decidedly the best practice to close the wound. The proceeding is of the same kind as the introduction of the sutures through the abdominal parietes in closing the wound in abdominal section. Fairly strong catgut or fine silk may be passed by means of a suitable needle through the anterior vaginal wall, very superficially through the raw surface of connective tissue, and then through the torn anterior peritoneum; a good hold being taken of vagina and peritoneum. The needle is then passed posteriorly through the peritoneum, which has formed part of the floor of Douglas' space, and finally through the posterior vaginal wall. The whole chasm in the pelvic floor may be thus closed, with the exception of the two extremities through which the long ends of the ligatures of the broad ligament pass. These ligatures may be conveniently twisted into a cord at each end, and held out of the field of operation.

After Olshausen's success in completing the operation by cutting short the broad ligament ligatures, and completely closing the wound in the pelvis, I tried for a time to do without drainage, but found the result unsatisfactory. Several times, owing to unfavourable symptoms which followed, it was necessary to undo some stitches in order to permit of the escape of retained fluid; since then I have always used at least one drain of perforated and carefully prepared rubber tubing, which is inserted into one or other extremity of the wound. After the withdrawal of the sponges a final swabbing of the ligatures, and of the vaginal pocket which is formed when the sutures are drawn tight and tied, is now all that is necessary before applying iodoform and iodoform gauze sufficient to support the pelvic floor and to act as a drain. It is not advisable, from the unfounded fear of prolapse, to pack the vagina very tight with the gauze. In one case, at least, I have seen very distressing symptoms immediately following the operation, symptoms so severe as to suggest intestinal obstruction, immediately relieved by removal of the vaginal tampon. If the ligatures are sufficient in number and firmly tied, there should be no anxiety about primary or secondary hæmorrhage.

The after treatment is, as a rule, extremely simple: it is almost purely expectant. If the ligature has been used it is not necessary to interfere with the parts for several days. There may be at first considerable blood-staining on the external pad; if, however, there are no constitutional signs of hæmorrhage, it is not advisable to undo the dressings. The application of the ice-bag in the iliac regions, the use, perhaps, of a hypogastric pad, and the administration of considerable quantities of warm neutral fluid, will almost certainly stop or make up for too profuse drainage. The pulse and temperature will indicate whether the progress is normal or whether complications threaten; in most cases after the first day there is in the repose and absence of symptoms a suggestion of the normal puerperium. Septic peritonitis is the danger at this stage; fortunately it is not common: when it does occur it may run a very rapid course in spite of irrigation and free drainage.

In elderly subjects pain is not much complained of; but in younger patients the lumbar pain may be excessively severe, and require the administration of morphia. There is no evidence that morphia does the patient any harm; and there can hardly be a question whether the surgeon be justified in leaving his patient to endure tortures which she was not led to anticipate when she assented to the operation. Whether morphia be administered or not, it is advisable to stimulate the peristaltic action of the intestines, in order to avoid, if possible, the principal danger not yet passed; namely, obstruction of the bowels. After thirty-six hours — when, if no adverse symptoms have arisen, one may say with confidence that the danger of septic peritonitis is over — the aperient may be administered. I prefer one-grain doses of calomel administered at intervals of an hour, and as many as five grains may be given in this way if no unfavourable symptoms appear. If flatus now begins to pass freely with the aid of the rectum tube the danger of obstruction is also at an end. The aperient may be supplemented by the administration of a saline; and at this stage I have reason to prefer one or two drachms of the sulphate of magnesia made into a lemon syrup and administered warm. The drainage tube is, as a rule, of no further use after the first three days, and it may be withdrawn.

Towards the end of the first week there may be some suppuration; and it is well, if this come on, to change the dressings every day, swabbing the parts well during the process with a warm antiseptic solution. In the second week the ligatures come away; occasionally it is advisable by traction to anticipate their spontaneous expulsion.

There does not seem to be any danger of the occurrence of hernia owing to weakness of the pelvic floor; it would seem that after a very few days such adhesions are formed within the pelvis as to prevent any considerable force from acting on any one point in the cicatrising wound. Nevertheless, considering the need for every possible advantage of physical and mental repose, with efficient nourishment and the influence of the best sanitary conditions, I do not think we render our patients a good

service in hurrying them out of bed so that we may point to a "record" time of operation and convalescence. Most of our cases are hospital patients, and I always feel that the longer we can keep them and nurse them the less risk there is of the recurrence of the disease.

So numerous are the modifications of this operation, that it might almost be said with literal truth that each operator who has done any considerable number of operations has called attention to the advantages of some modification of his own.

The method of turning the uterus upside down, which was universal at first, is now given up. After partial division of the broad ligament on each side, the manipulations by the volsella were carried out until the fundus uteri could be seized and dragged down through either the anterior or posterior opening. The result of this manœuvre was to twist the broad ligaments, which could then be tied in bulk. Its drawbacks soon became obvious enough. The method led more readily than almost any other to the ligation of the ureters, and owing to the mass of tissue tied, hæmorrhage, from slipping of ligatures, was too frequent a result. Some slight modification of it, however, to meet special difficulties, may be still introduced during the operation.

Among other modifications is that of Fritsch, who begins the operation at the sides; this enables him to tie the uterine vessels at a very early stage of the proceedings, and to diminish hæmorrhage. It is a modification which can, no doubt, be very readily applied to the less advanced cases.

The thermo-cautery has been introduced by Säger to divide the vagina all round so as to prevent hæmorrhage, and to save the time otherwise required to introduce the ligatures. The advantages and drawbacks of the introduction of the thermo-cautery at this stage of the operation must be obvious to any one who has attempted to use it. Mackenrodt goes further still with the use of the cautery; he has reported several cases in which he trusted to the use of the thermo-cautery to divide the tissues including vessels throughout the operation. He appears to believe in it as a safe and effective method of operation, and he claims for it that recurrence by inoculation is less likely to take place.

The clamp is, however, the principal modification in the operation of extirpation of the uterus. Its advantages are maintained mainly by Richelot and Péan in France, by Landau and others in Germany. There are already many inventors of clamps for which special advantages are claimed, but at the present time it does not appear that the clamp operation is making headway. The clamp certainly shortens the operation, and it is much easier with it than with the ligature to control hæmorrhage from infiltrated tissue. Some of the disadvantages of the clamp, however, are obvious enough. It prevents the closure of the wound in the pelvis; that is to say, the completion of the operation. It involves danger of tearing through the tissues held by it, and consequently of producing hæmorrhage. This must always be the case so long as any portion of the clamp remains external in the dressings. Then the



destruction of tissue by necrosis, and the interference with the dressings on removal of the clamp, must produce a distinct danger of septic infection. In some of the cases reported the intestine had been nipped by the point of the clamp, which was away beyond reach; this is an accident that should hardly occur in the hands of a careful and experienced operator. To a different class of accidents belongs the catching of the ureters by the clamp, which is said to occur more frequently than in the ligature operation: in any case it is an accident which may occur in the hands of the most careful.

*Results of Total Extirpation per Vaginam.*—So numerous and voluminous have been the publications dealing with the results of operations for cancer of the uterus during the last few years, that one can only select a few reports as types of their class, in order to call attention to the practical conclusions which the perusal of many of them suggests.

A few years ago, when the operation was just beginning to gain a footing in England, Dr. William Duncan called the attention of the medical profession to it. From his own experience, and the results culled from numerous publications, he came to the conclusion that the operation involved a mortality of 25 to 30 per cent. This discouraging result depended upon the fact that a large number of the operators had only one case to report. With greater experience the results of the operation have marvellously improved; and they may be considered supremely satisfactory, even without applying the illusory or impossible standard of "the best results of the most experienced operators."

If we analyse the report of Krukenberg already referred to, we find, during  $5\frac{1}{2}$  years ending April 1891, a very large proportion of the cases of malignant disease of the uterus were considered operable: 292 in 924, or 31·6 per cent. The 292 radical operations were made up in this proportion: 235 times vaginal hysterectomy, 44 times supravaginal amputation, and 13 times supravaginal amputation after abdominal section. Of the radical operations, 197 were for cancer of the cervix, with the following results: 25 died directly in consequence of the operation, that is, 12·7 per cent. Recurrence of the disease appeared in 69 within one year. Pyometra was the worst complication, nearly all the cases being fatal from infection. Nine of the patients were alive and well at the end of nine years. Important information bearing on prognosis is given regarding 48 cases which remained free from recurrence, and 55 in which the disease had reappeared. (i.) Of cases of carcinoma of the mucosa of the cervix in the early stage, recurrence took place in 33·3 per cent. (ii.) Of cases of superficial ulceration of the portio, there was recurrence in 36·4 per cent. (iii.) Of small cauliflower excrescence, recurrence in 42·4 per cent. (iv.) Of advanced carcinoma of the cervical mucous membrane, recurrence in 58·8 per cent. (v.) Of carcinoma involving the walls of the cervix, recurrence in 60 per cent. (vi.) Of greatly developed cauliflower excrescence of the portio, recurrence in 62·5 per cent. (vii.) Of deep ulceration of the cervix, beginning as epithelioma of the portio, recurrence in 80 per cent.

With regard to influences favouring recurrence nothing definite appears from the figures except the site and extent of the disease. Upon the whole, women over 45 years of age showed less frequent recurrence than women under 45.

Among figures for a period practically the same we have those of Terrier and Hartmann. In 36 cases there was a mortality from the operation equal to 23·5 per cent. Seven patients, at a sufficiently remote period, were considered permanently cured. They put down recurrences at 70 per cent, and cures at 30 per cent.

Richelot (38), publishing the results of four years' work in 1892, shows a greatly diminished mortality, the causes of which may be inferred from the facts. He performed 225 operations, with 11 deaths; that is, 5 per cent. He used the clamp exclusively, and argues in its favour. He had no hæmorrhage either primary or secondary. He does not think the ureters are in greater danger from the clamp than from the ligature; he never caught intestine with his instrument; and he does not believe that the clamp narrows the field of operation. As a drawback he mentions that the clamp is more painful to the patient.

Bürkle, in an inaugural dissertation in 1892, gives a summary of the operations, mostly German, up to the date of publication. He mentions 273 operations of total extirpation with a mortality of 10 per cent. Among the causes of death were: septic peritonitis in 22 cases; ileus in 2 cases; and hæmorrhage, pneumonia, and heart failure in one case each. Among the incidents of operation were: incision of vagina and perineum, 5 times; pyosalpinx, 4 times; pyometra, 17 times with loss of 7 patients; complications with myomata in 9 cases; ovarian tumour of considerable size, in 5 cases; injury to the ureter in 4 cases.

From an account of Kaltenbach's work at Halle, published by Bücheler, we see how improvement went on in method as well as in results. The chief modification in Kaltenbach's method was suturing of the peritoneum in the pelvis; he also employed antiseptics in a very stringent fashion. The total number of operations was 159, and the mortality was at the rate of 3·9 per cent. This was by a long way the lowest mortality at the time of the completion of the work. Among the accidents in the course of operation were injury to the bladder, producing fistula; injury to, or tying the ureters, and the production of a fæcal fistula: once a sponge was left within the pelvis. The number of operations for cancer of the cervix was 134. There were free from recurrence at the time of publication, 19; and four had remained free for over three years, with fatal recurrence afterwards. The ligature was used exclusively in operation.

In 1894, Abel of Berlin published a paper on total extirpation, which was chiefly an argument in favour of the clamp. He mentioned that he and Landau, who also uses the clamp exclusively, had a mortality of 5·4 per cent over a total material of 93 cases.

Zweifel's mortality up to the same time was almost exactly 5 per cent. Mangiagalli has given an account of the immediate and remote

results of his operations with such comments and quotations that a summary of his contributions might completely serve our purpose. He gives an analysis of his cases according to site of the disease, the extension of the disease, and the method of operating, whether by ligature with closure of wound, or without closure of wound, or by the clamp.

For example: in carcinoma of the cervix:—

Without diffusion to vagina, etc., 46 cases, 45 recoveries, 1 death, mortality 2·17.

With diffusion to vagina, etc., 36 cases, 30 recoveries, 6 deaths, mortality 16·66.

In his 1st class—operations by ligature without suture of the wound—there were 23 cases, 20 recoveries, 3 deaths, that is a mortality of 13·04 per cent.

In the 2nd class—operations by ligature with suture of the pelvic wound—40 cases, 38 recoveries, 2 deaths; a mortality of 5 per cent.

In the 3rd class—use of the clamp—25 cases, 22 recoveries, 3 deaths, a mortality of 12 per cent.

Mangiagalli concludes that the mortality from extirpation for cancer of the body is greater than for cancer of the cervix; but his material is perhaps too small for generalisation. One conclusion brought out by his figures on which he lays much stress is: “The most important element in the prognosis of vaginal hysterectomy for cancer of the cervix is the extent of the diffusion to the vagina and parametrium.”

In discussing the remote results the author accepts provisionally the criticism that the disease may be considered cured if there be no recurrence within two years; and shows that, according to the way in which deductions were made, his results would be at the rate of 38 to 44 per cent of cures. The German operations selected show from 36 to 64 per cent of such cases. In many of the contributions on the subject of results there appears to be a tendency to hold a sort of inquest on every death, and to draw up percentages according to the verdicts obtained after explaining away the causes of death.

Richelot (39) gives the results of his operative work down to August 1895. He published an account of 274 cases of vaginal hysterectomy dating to the end of 1893 with the results, namely—

44 cases of uterine cancer . . . .	3 deaths.
61 „ pelvic suppuration . . . .	5 „
126 „ non-suppurative affection . . . .	5 „
43 „ uterine fibroma . . . .	1 „

The total mortality is 5·10 per cent.

From the end of 1893 to the 1st of August 1895 he had performed 202 additional operations:—

14 cases of uterine cancer . . . .	3 deaths.
66 „ pelvic suppuration . . . .	3 „
89 „ non-suppurative affection . . . .	2 „
33 „ uterine fibroma . . . .	2 „

Still a total mortality of practically 5 per cent, but with a very high mortality for cancer operations. The figures for operations undertaken on other grounds are given to indicate how little inherent danger there may be in the operation itself; any further remark would be irrelevant.

After such statistics it is much of a drop to come to my own figures. I began to operate early in the history of vaginal hysterectomy (September 1882), and I have operated when I anticipated an advantage for the patient, after allowing for risk, operative distress, and injury to the general health. My cases have consequently included a considerable proportion where some invasion of the vagina and parametrium existed. It is some comfort to find that others, witness Mangiagalli, have had even a higher mortality in such cases. The tendency of isolated operators is, I imagine, to try operation on cases too far advanced, in the hope of giving the patient a chance. It is only the close observation of recent years that has shown how futile such operative work must be.

My first 10 cases were published in the *Practitioner* in 1889; 4 of the patients died, giving a mortality of 40 per cent. Up to the time of beginning to close the pelvic wound in 1890, I had operated another 12 times with 1 death.

From the time of closing the wound completely I had 2 deaths in 1890, and so I began drainage as well as closure. From the time of drainage to the end of July 1894, there was a further series, making 45 cases with 7 deaths, a mortality of 15 per cent. Up to that time also there were 15 private cases of cancer of the portio and cervix, with 1 death, making a mortality of  $6\frac{1}{2}$  per cent. Partly before and partly since July 1894 there have been 5 cases of cancer of the body. All these patients recovered from the operation, and all, so far as is known, are still free from recurrence.

Considering the physical wrecks some of the patients were at the time of operation, and the stage which the disease had reached, we can only wonder that even this modified success was achieved. The operations are all given without deduction on account of any process of "inquest" on fatal cases. But for the operation no patient would have died at the time she did.

Few cases have been seen in the most favourable stage for operation, hence the frequency of recurrence has been disheartening. Such patients are difficult to trace, and I only know of two now alive and well who were operated on for cervix carcinoma before the autumn of 1890.

*Recurrence after Operation.*— Under the head of the course and symptoms of cancer of the vaginal portion and cervix, we may best consider the modes of recurrence after operation. In by far the greater number of operation cases it is the cervix, or part of it, which is affected; and it is after operation for the malignant disease of the cervix that recurrence takes place in the vast majority of cases.

For our present exact information on this subject we owe much to Winter (57), who carefully observed 59 cases of recurrence, and published the results obtained. He divided the cases observed into three classes:



(a) *Recurrence by metastasis* ; (b) *Lymphatic recurrence* ; and (c) *Local recurrence* ; that is, at the site of the wound.

With regard to *metastasis*, all observers are agreed that it is not common as a result of uterine cancer. Gusserow summarised the opinions which prevailed before total extirpation of the uterus. Metastases, according to Blau and others, occurred in the liver in 9 per cent, in the lungs in 7 per cent, and in the kidneys in 3·5 per cent of the cases which ran their course. In women who have undergone the operation of total extirpation metastases are almost unknown. In 43 cases of recurrence after operation, in which he made a post-mortem examination, Winter did not find a single case with metastasis. In 202 cases of recurrence only 9 were real examples of metastasis. Only 2·5 per cent of all women operated upon suffered from metastases, which occurred in the stomach, lungs, liver, and ovaries.

*Lymphatic recurrence* is of more importance. From the cancer of the cervix the glands which become affected are the iliac ; these lie close to the sacro-iliac synchondrosis, just below the brim of the true pelvis, and at the point of division of the iliac and hypogastric arteries. From cancer of the body the lumbar glands are affected. These may develop into masses in which the aorta is embedded, and they may be felt high up in the abdomen. Occasionally by anastomosis the obturator and inguinal glands become affected. Infection of the pelvic glands is not so common as we might expect ; and it occurs comparatively late. Blau and Dybowsky, on post-mortem examination in 203 cases, found infection of the glands only 40 times. Winter, in the post-mortem examinations of 43 women, who had undergone the total extirpation operation, found the glands involved only three times, and in only one case was the cancer confined to the uterus. In operable cases in clinical examination he found the glands infected three times ; when the parametrium was involved the glands were found to be infected in 24 per cent of the cases. Pure lymphatic recurrence is rare ; it is in conjunction with recurrence in the cicatrix that the glands are found most frequently affected.

*Local recurrence* is by far the most frequent form. It occurs in the cicatrix, in the bladder, peritoneum, pelvic cellular tissue, and vagina. The most common cause of this relapse is without doubt the incomplete removal of the affected tissue at the operation. This recurrence is then very early, as a rule. All observers agree that one chief cause of recurrence is permitting cancerous material to come in contact with the peritoneum or freshly wounded tissues. The disease is then an inoculation recurrence ; and this infection appears to take place only on account of that special state of health of the patient, which made the original disease possible. The recurrence in the vagina has some points of interest of its own ; it must be a fresh development of the disease produced by prolonged contact of the cancerous growth with a surface not specially susceptible. The first time I saw this was in a patient who underwent the total extirpation operation on account of cancer of the cervix which

had grown into a mushroom mass, lying in contact with the posterior vaginal wall. At the operation it was found that there was considerable vaginitis high up, and there was one spot in particular on the posterior wall with broken down epithelium. It was red and moist and sore-looking, but it was distinctly separated from the vaginal portion by a space of comparatively healthy tissue. Taking it for a vaginitis produced by the discharge, I did not entirely remove this affected portion of vagina, and was disappointed a few months later to find a new growth of epithelioma developing from the area which had apparently been the seat of an inflammatory affection only.

Many such cases have been reported, and they go to prove the infectiousness of cancer by prolonged contact in suitable subjects.

The study of recurrence leads at every point to important practical conclusions, especially with regard to the need for extreme care to prevent infection at the time of operation.

*Sacral Method.* — The sacral method of operating with which the names of Kraske, Zuckerkandl, Hochenegg, and others are associated, has been practised a good deal in Germany, but has received little attention in this country. The advantages originally claimed for it were the facility with which the field of operation could be reached and kept fully in view, and the widening of the scope of the total extirpation by sweeping away the affected parts more thoroughly than was practicable by the vagina. It is also said to be more suitable in cases of cancer of the body with enlargement of the uterus and senile narrowness of the vagina. With this indication Fritsch agrees.

An obvious disadvantage is that it involves resection of part of the sacrum and consequently a prolonged convalescence. In some of the cases first reported the sacrum not only did not again unite, but even necrosed, with corresponding sloughing of connected soft parts. One such misadventure occurred to so experienced an operator as Hegar.

Many proposals were consequently made for improving the operation, and perhaps as noticeable a modification as any was that proposed by Herzfeld (18). It is necessary, according to him, to resect the coccyx only, or at most about one centimetre of the lowest part of the sacrum in addition. An incision is made along the medium crest of the sacrum, and carried in a slight curve to the periphery of the anus on the right side. The recto-vaginal septum is then easily found, and the deeper parts are separated with the finger tip or handle of the scalpel. The prevertebral fascia is thus brought into view, and is cut through along the right margin of the rectum. Herzfeld claims for this detail in the operation that the rectum does not come in the way, and it is more easy to reach the posterior surface of the vagina which can be drawn to the right. The vagina is easily distinguished by its whiter appearance. Between the right margin of the rectum and the point of the posterior vaginal wall the lowest portion of Douglas' space is sure to be found. Some recent critics of the operation say that they have met with considerable difficulty here.

Herzfeld takes the *plica transversalis recti* as a landmark, and can with confidence open Douglas' space on the right margin of the rectum at this point. The wound is cautiously extended, and then the uterus with its adnexa can be drawn through in such a way that its anterior surface now looks upwards and backwards. On this surface the line of reflection of the vesico-uterine fold of peritoneum can be distinctly seen. This portion of peritoneum is cut through, and the uterus is then separated from the bladder down to the anterior insertion of the vagina. The left broad ligament is now dragged upon, ligatured and cut, and after this the peritoneal opening is completely closed with sutures which bring together the posterior margin of the peritoneum in Douglas' space, and the cut margin of the vesico-uterine fold. The rest of the operation, which involves manipulation of the cancer, is entirely extraperitoneal. It is claimed as an advantage for this proceeding, that it prevents infection of the peritoneum by cancer juice or cancer elements, and thus helps to prevent the recurrence of the disease.

The broad ligaments are now tied in sections and cut downwards to the *portio vaginalis*. It is said that during these proceedings the vessels and ureters can be distinctly seen and properly dealt with. The posterior wall of the vagina is finally cut through and, when the incision has been carried round, the uterus can be removed. It is claimed for the operation that the ligatures can be placed upon the broad ligaments as far outwards from the uterus as may be necessary, and the vagina, if affected, can easily be resected to any required extent.

The upper opening of the vagina may now be closed with sutures, and drainage effected through the original wound made in gaining access to the field of operation; or the wound may be closed and the vagina be left open for drainage. The latter course was suggested by Schauta, and appears to be preferable.

The author of this superior modification of the sacral method admits that it does not extend the scope of the operation, inasmuch as when the parametrium is involved it gives no better results than any other method of surgical treatment. What is said of it by the most reasonable and most highly qualified of critics may be best stated in a summary of Von Winckel's remarks on the subject. He had done the operation in a suitable case, and in doing so had observed some points which he had not previously heard anything about. He had to dissect higher up than he had been led to expect. When the *fascia* was cut through air rushed in and pushed all the parts to the left; this caused considerable delay, and consequently more loss of blood than is usual in the vaginal operation. The separation of the left side of the uterus and its ligation was extremely difficult. As to the ureters, he could not find them at all, although he searched for them; and he is sure that in this operation they are not more easily avoided than in the vaginal operation. The result of the operation was unsatisfactory: the vagina became fixed above, and sutures were expelled through it; a fistula formed in communication with the bone, small spicules of bone continued to be shed for months afterwards,



and the convalescence was very slow. His conclusion is that if by so radical an operation we can obtain no better result than by means of the curette or the cautery, we are bound to tell the patient frankly that we can promise nothing better, and to let total extirpation alone.

Recent reports suggest that some Continental gynæcologists have taken this advice to heart.

*Freund's Operation.* — After the first dubious successes of Langenbeck, Blundell, and Récamier, in vaginal hysterectomy for cancer, early in the present century, all radical operations were given up for about forty years. In 1878 Freund, of Strassburg, performed the first successful operation with which his name is associated. It consisted of a vaginal and an abdominal operation; and in spite of the tedious details which it involved, and its technical difficulties, it was performed by many gynæcologists in Germany and elsewhere in Europe, and by a few in England. The eagerness with which it was adopted is in some degree a sign of the conscious helplessness of surgery in dealing with uterine cancer at that time.

It was soon discovered to be a very fatal operation, and many modifications were soon introduced in the hope of diminishing the mortality, but with only slight success. The dangers consisted chiefly in the shock from long exposure and manipulation of the bowels, obstruction from paralysis of the intestines, hæmorrhage, infection from the cancerous elements, peritonitis, and injuries to the ureters and bladder. Modifications were carried to the extent of dividing the recti muscles, and even of resecting the anterior pelvic wall. The danger is indicated by the statistics of the early period of the operation collected by C. von Rokitsansky. Of ninety-five women operated upon, sixty-five died directly from the effects of the operation; and in all the remaining cases the disease soon recurred.

It may be said that the operation has been abandoned except to meet a certain comparatively rare combination of circumstances, as in cancer with myoma or in large sarcoma of the uterus. There is, perhaps, quite recently a disposition to give the operation more attention, since such satisfactory results have been obtained in the similar operation for fibromyoma of the uterus.

H. W. Freund (9), who may naturally be disposed to think well of the operation, recently gave the results up to date (from 1886) as showing a mortality of 33 per cent in twenty-seven cases. Up to 1886 the mortality for all the cases collected was 67 per cent. In ten recent cases at the Strassburg Hospital there were two deaths from the operation, and two more within a few weeks.

The technique of the operation, with all improvements as now performed at Strassburg, is shortly as follows: The patient is put on the table, and the pelvis raised into the high position (*Beckenhochlagerung*) by means of a suitable pad placed under the hips. The vaginal wall is incised round the portio vaginalis; Douglas' space is opened as completely as possible, and a sponge is pushed through the opening. A



suitable hydrostatic dilator or bag is introduced into the vagina and made as tense as possible; by this means the uterus is raised out of the pelvis, and thus the abdominal part of the operation is much facilitated. When the abdominal cavity has been opened by a full incision the process of separating the bladder from the uterus is at once begun, and is easily completed with the guidance of a sound. The old practices of drawing out the intestines and distending the bladder have been given up. The appendages and the broad ligaments are tied in sections and cut through on each side as in the ordinary operation; and owing to recent modifications this part of the operation is remarkably easy. The ligatures of the broad ligament, which are left long, are now drawn down through the vagina; and the anterior and posterior cut margins of the peritoneum are brought together with sutures. The peritoneal cavity may be completely shut off from the vagina, or a sufficient opening left for drainage.

*Partial Extirpation.* — The operation which is the rival or alternative to total extirpation is not any one of the modifications mentioned, but partial extirpation, or high amputation of the uterus. This operation was the first great step in advance, in the surgical treatment of uterine cancer, beyond the futile and sometimes injurious measures formerly in vogue, such as the application of caustics or escharotics, and the use of the chain ecraseur or the galvanic ecraseur. There can be no doubt that excellent results were obtained by the partial extirpation of the uterus, and some able, experienced, and conscientious gynæcologists still maintain that it is the best operation, and endeavour to restrict total extirpation within the narrowest possible limits. But even its strongest advocates have to admit that it is losing ground. One of these (58) begins his advocacy of the partial operation as follows: — “The total extirpation of the uterus per vaginam has become more and more the favourite operation of the German gynæcologists. The safe and even elegant technique, the brilliant results, and the permanent success are constantly adding to the number of those who speak well of it. The foreign gynæcologists gradually follow the lead of Germany, so that now scarcely an opponent of the operation may be said to exist. Schroeder’s operation of amputation of the cervix for cancer of the portio vaginalis has become so completely obsolete that it is scarcely ever referred to in works on total extirpation, much less brought into comparison with it.”

The introduction of the operation of partial extirpation of the uterus is usually attributed to Schroeder, who continued to practise it after most of his contemporaries had declared for total extirpation. The practice and advocacy of the operation appear to have been carried on mainly by Hofmeier, Winter, and other pupils. In this country Sir John Williams has been the chief advocate of partial extirpation; in fact, the portion of his work which he devotes to the surgical treatment of cancer of the uterus is largely an effort to prove that, in cancer of the portio vaginalis and of the cervix, total extirpation of the uterus possesses no advantages over supravaginal amputation of the cervix. He endeavours

to establish his proof by evidence from pathology and from clinical experience.

The argument from pathology depends almost entirely upon the belief that cancer of the cervix begins in certain situations, and has a tendency to grow downwards or outwards towards the parametric connective tissue. This is not the place to go into controversial details, but it may be stated with confidence that more recent observations lead to the conclusion that the views stated are not consonant with the facts, and therefore the argument for partial amputation, so far as it depends upon the facts, entirely fails.

With regard to what may be called the clinical argument, Sir John Williams asks: What does the experience of operators tell us on the subject? A good deal has happened since *Cancer of the Uterus* was published in 1888, and the views of some experienced operators may be inferred from the language used by Winter three years later. At a time when total extirpation was looked upon as a formidable and dangerous operation it was natural enough to endeavour to make the most of the partial operation; but it has been proved by the results of operators within the last few years, that total extirpation is not necessarily a more dangerous operation than supravaginal amputation. On the relative frequency of recurrence after the two operations, and the comparative length of time of immunity, no satisfactory conclusion can be drawn from such arguments. It is almost invariably a comparison of unlike things, because the operation of partial extirpation was reserved for the most favourable cases; it was only when the disease was more advanced that total extirpation was attempted by the early operators. Considering the improvement in the technique of the operation, and the encouraging results of the most experienced operators, who deal with all cases by total extirpation, the advantages appear now to be almost entirely on the side of total extirpation.

The object of the partial operation is to operate within healthy tissue in the parametrium, and to reach up as high as possible without opening the peritoneum. It is claimed for the operation that it is comparatively easy of performance; that there is little shock; that the field of operation is entirely within the operator's view and control, and that ileus and peritonitis are avoided. One advocate, at least, of the supravaginal amputation seriously states, as a point in favour of partial operation, that a woman may become pregnant and even go to full term after having the cervix uteri removed for cancer, and he produces several cases from the literature of the subject. He is able to show also, although our attention is not specially drawn to the fact, that some of these women who became pregnant soon lost their lives from recurrence and rapid growth of the disease. Women before the menopause are liable after high amputation to cicatricial contraction of the lumen of the uterine canal, and to constant sufferings dependent upon that fact. The avoidance of so grave a result of the operation is in itself a very strong ground for proceeding to total extirpation. In favour also of total extirpation is the

fact that we can never be certain of the extent of the diseased tissues. Many cases are reported in the literature of the subject, and I have myself seen several, in which there were distinct centres of development of the malignant disease; and consequently partial extirpation would have been a useless operation. Then again, in the partial operation there is a much larger, and a less completely finished wound than in the complete operation; so that, with an extensive surface which should granulate, there is probably more danger of parametritis and diffusion of the cancer than there is when the broad ligaments are efficiently ligated, and both blood-vessels and lymphatic channels are almost completely cut off.

After all operations for cancer of the uterus, the recurrence takes place most frequently in the site of the wound, and in women who are still menstruating it stands to reason that recurrence is less likely to take place when quiescence of the parts is brought about by the complete operation. Theebb and flow of menstruation, and the influence of blood-supply on the nervous system of the parts by emotional conditions in the ante-climacteric age, are much more likely to bring about recurrence than when, by complete removal of the uterus, and perhaps of the ovaries as well, the menopause is prematurely brought on.

It seems to me that there is only one clearly definite class of case of cancer of the portio vaginalis in which partial operation may be the best operation; that is in elderly or old women, in whom the disease is very slowly developing, and in whom the uterus is perfectly movable, and the vagina narrow and senile.

With regard to the technique of the operation it is hardly necessary to go into details. It is really almost invariably identical with the first stages of the complete operation. One point in the operation, which should be considered essential, is the timely shutting off of the blood-supply by the uterine arteries; after that is done the separation of the cervix from its surrounding structures and its amputation are comparatively easy proceedings, unembarrassed by any considerable amount of hæmorrhage.

*Palliative Operations.*—When the cancer is too far advanced for any radical operation the question always arises whether any benefit at all can be conferred by local treatment. The patient has reached the stage at which symptoms have to be treated as they appear; but such treatment is dreary and unsatisfactory work, and every available means should be brought into use which offer any reasonable ground for the expectation of benefit. In a considerable proportion of the advanced cases there is a deep ulcerating cavity which may contain spongy débris, the result of the necrosis of the uterine tissues. In such cases there is a foul and copious discharge with intermittent attacks of hæmorrhage. These are the cases in which the sapræmic process at work is also doing the most harm in sapping the patient's strength. What means of local treatment worth employing have we at our disposal?

1. *The sharp curette* is naturally placed first; whether it be used

alone or supplemented by some chemical agent to destroy the infected tissues further.

In such patients we cannot use the curette efficiently without the aid of an anæsthetic. Yet when there are grave objections to the administration of chloroform or ether, the operation may still be carried out more or less completely without inflicting much pain. In such cases I have found it of great advantage, about an hour before the time appointed for operating, to give a considerable hypodermic injection of morphia; and just a few minutes before beginning a fair dose of whisky or brandy well diluted. When these medicines have taken effect it is wonderful how well the patient can bear even a tolerably thorough use of the instrument.

In an ordinary case, when the patient has been put under the anæsthetic, it is best to place her on a table in a good light, and proceed with all the care as to detail and all the circumstance of an important operation. The reason why so many private patients are treated so inefficiently as compared with our hospital cases is largely, I believe, because we give too much heed to paltry objections to exposure, to the use of an operating table, and so forth. The patient is placed in the lithotomy position, and the parts are thoroughly brought into view with the aid of the weighted speculum. The uterus and vagina are thoroughly swabbed with a solution of mercury which helps to deodorise as well, and the uterus is, if necessary, steadied with a volsella. The broken down tissue is then rapidly swept away, and every portion of the cavity is carefully gone over in detail until the instrument is felt to rasp upon firm tissue. It is occasionally necessary to cut away tags of comparatively healthy material, chiefly at the margins of the ulcer. The cavity is frequently swabbed with cotton wool soaked in mercury solution, and is finally packed with gauze or lint wrung out of the same solution.

Such an operation has its uses in stopping hæmorrhage and foul discharge for a time, but only comparatively slight and evanescent effects are to be expected from it.

If the curette be worth using, its action should be supplemented by an escharotic; and of all the substances available at present there can be little question that zinc chloride is the best. It should be put ready beforehand to apply immediately after the curetting, and it should be in the strongest manageable form. A solution of one in two or three, or a paste of equal parts of the chemical and moist flour, answers very well. It may be applied advantageously on the end of a shred of lint like a narrow bandage, the dry portion being packed in after, so as to keep the active agent in its place. Every care should be taken, by pledgets of cotton wool or lint soaked in a strong solution of soda bicarbonate, to protect the vagina from any surplus zinc salt. It is a good plan to finish by packing the vagina with a tampon consisting of a long strip of lint soaked in a strong solution of soda. This tampon may be left for a day or even for two days; it is then removed and an antiseptic douche copiously used.



There are many other methods of employing this treatment, but there is no difference in essential details. From very considerable experience I can speak well of the method here described.

The eschar keeps coming away in shreds or in liquid under the use of the douche for a week or so. During this time, and it may be for long afterwards, a marked change for the better takes place in the patient. The sapræmic temperature goes down; she is comparatively free from pain; the hæmorrhage ceases; the discharge is greatly modified in many respects, and is almost free from smell; the cavity may take on the appearance of a healthy granulating surface, covered with a thin matterly discharge. Later, the cavity gradually contracts, cicatricial tissue forms, and the improvement may last for many months. Meanwhile the patient becomes stronger. She puts on flesh, and loses in a great measure the anæmic or cachectic appearance.

Some one or other of the above palliative operations may be used repeatedly with advantage when hæmorrhage and foul-smelling discharge show that the ulceration is making progress.

It has been raised as an objection to the curette that there is danger of perforating the uterus, and some cases have been reported in which this "accident" has occurred. But the same kind of objection might be made to many of our most useful medical and surgical means of combating disease. Some drugs are powerful poisons, and all scalpels should be sharp. Two conditions are required for the successful use of the curette: the case selected for treatment must be suitable, and the instrument must be used with reasonable care and skill. When so employed the curette is one of the most useful instruments the gynæcologist has at his command.

The curette does sometimes cause considerable hæmorrhage which is not easily stopped. It is occasionally necessary to use a very firm tampon and even counterpressure from above the pubes before it ceases. But as a rule the amount of bleeding is very slight, and the oozing ceases at once on the introduction of the tampon with zinc solution.

A more valid objection is the fear of too extensive an action of the zinc chloride upon the tissues. This objection applies to nitric acid, and to other less manageable and less useful chemicals which have been used for the same purpose. If care be taken to ascertain the depth of uterine tissue between the ulcer and the peritoneum, and due allowance be made, the danger is reduced to the minimum; and the result may fall little, if at all, short of that obtained by supravaginal amputation.

The chemical substances which are occasionally applied, alone or in supplement to the curette — such as lunar caustic, iodine solution, bromine, sulphate of copper, solution of the perchloride of iron, and so forth — ought all to be discarded. They are difficult to control, and are consequently liable to cause injury to healthy parts; or they may produce discoloration of the tissues and an ambiguous state of the infected area, an ambiguity as likely as not to be cleared up in the revelations of an increased rate of growth due to the irritation.

2. *The Cautery.* — The use of the cautery is one of the best methods of dealing with inoperable cases of cancer of the uterus. It appears to be a special favourite in German *Kliniks*; but it has not hitherto received the attention in this country which perhaps it deserves. One of the difficulties we have to meet in the efficient use of the cautery is to find a suitable instrument. The ordinary cautery, prepared to a white heat and then applied when it is getting dull, is theoretically one of the best; but, unfortunately, in practice it invariably gets cooled down too rapidly, and it is necessary to wait, with the patient under the anæsthetic, until the instrument is again heated; or to keep a series of the instruments hot and use them at intervals. The same objection applies very largely to Pacquelin's cautery. It is applied apparently in perfect order, but it is liable to be cooled down by the blood, and time is lost in again reheating it; at least, such is my experience of the use of the cautery in this operation.

One of the most effective forms of cautery is the galvanic, which consists of a suitable stem for application, with means for turning on and interrupting the current; the effective part of it consists of a porcelain button surrounded and covered with platinum wire which is connected with the battery. This cautery as a rule works well, but I have repeatedly found that if we attempt to increase the strength of the current as the button cools down, the platinum wire gives way and the operation suddenly collapses. All the objections, also, which may be reasonably brought against the use of the curette are yet more applicable to the use of the cautery. Among the chief advocates of this method of palliative treatment we must count Fritsch, who trusts to it as the means of destroying the infiltrated tissue, and of bringing about similar results to those obtained by the efficient use of chloride of zinc. He uses it as the special means of producing a result; not as a supplement to the use of the curette, as is strongly recommended by many operators.

Supposing, in any given case, the endeavour to use Pacquelin's cautery for the purpose of destroying the affected tissue in a case of crater-like ulcer of the uterus be resolved upon, the parts must be exposed by means of a tubular speculum which does not readily convey heat. The temperature of the cautery has to be kept up with the aid of an efficient assistant; and after the comparatively slight use of the curette the point of the cautery button is applied to all the suspected area. There is always a certain amount of hæmorrhage, and the blood has not only a tendency to cool the instrument, but to obscure our view of the field of operation. Fritsch trusts entirely to the cautery to produce the desired result, and an account of his method of treatment may be worth inserting here:—

The patient is placed in the lithotomy position, and the soft portions of the uterine ulcer are removed by means of the sharp curette or a large sharp spoon. The instrument is firmly and rapidly used to remove the whole of the soft infiltrated tissue; the main reason for prompt and rapid action being the important amount of hæmorrhage which so frequently

occurs. Shreds of uterine tissue which evaded the curette must be seized hold of by forceps and cut away. The crater is then thoroughly burned out by means of the point of the button of the Pacquelin cautery. If the actual cautery be employed, it should be used when it is becoming dull, not at the white heat. The burning by means of the cautery should be effected in a thoroughly energetic manner, working high up into the uterine tissues, and transversely into the parametrium. The process is continued until hæmorrhage is completely stopped, and until the surface of the tissues so treated, when tapped with the cautery point, produces an impression as if it were tapping upon horn or cartilage. If the speculum show any sign of becoming too hot it must be cooled down by means of cold water compresses. Where there has been great loss of substance there appears to be some danger of roasting tissues too close to the peritoneal surface of the uterus; it is better, then, to do a partial operation and repeat it in two or three days. After the burning the cavity is packed with a suitable tampon consisting of dermatol-gauze; the cavity is also treated with an astringent.

There can be little doubt that it is a good plan, even after such energetic use of the cautery, to pack the crater with an antiseptic tampon; and this tampon is best applied by means of an exceptionally long forceps; made very much in the pattern of the dissecting instrument.

After such an operation the completely destroyed tissues begin to be shed, either in the form of considerable shreds or of a liquid, the result of the breaking down of the tissue internally.

Fritsch does not think well of the chloride of zinc treatment which he has tried in all its modifications for between twenty and thirty years. He says it produces a hard cicatrix which becomes denser and harder and is ultimately the seat of neuralgic pain; and all this without stopping to any great extent the progress of the disease.

He prefers to apply the curette and remove the soft tissue; then to cauterise, and afterwards to continue to use tampons with a mixture of boric and tannic acid.

Among the agents which have been used in powder, suspension, or solution to delay the progress of the disease, to soothe it, and to deodorise it, may be mentioned alum, thymol, boric acid, salicylic acid, carbolic acid, creolin, lysol, and iodoform. There is something to be said for each of them; they are all chemical agents, possessing qualities which may be of service in inoperable cancer of the uterus.

3. *Interstitial Injections by the Hypodermic Syringe.* — Dissatisfaction with the treatment by curette and cautery has led to the attempt to treat cancer by the introduction of certain chemical substances into the parenchyma of the uterus, just beneath the infiltrated parts. The method has been largely of the nature of an experiment, and the results published cannot be considered brilliant.

Thinking that, if the bacterial element in a case of ulcerating cancer could be removed, the rate of growth might be diminished and some of the disagreeable features in a case might be more or less ameliorated,

the writer a few years ago tried the injection of small doses of a solution of perchloride of mercury into the tissues of the cancerous uterus; it would be too sanguine to describe the results as more than negative, except indeed that a good deal of pain was inflicted. The process has been tried again at our Cancer Hospital without any better results.

Within recent years, however, a considerable number of contributions to this therapeutic method have appeared in the medical journals, and it is claimed by the authors that they have met with encouraging success.

Bernhardt treated six cases with injections of salicylic acid solution (6 per cent), and expresses himself satisfied with the results obtained.

Schultz of Buda-Pesth appears to have begun this treatment amongst the first. He gives an account of thirty cases in which he injected alcohol; in his opinion with satisfactory results. The treatment requires much care and time; it is laborious for the surgeon and painful to the patient.

Vulliet also published an account of his method of injecting absolute alcohol. He reported four cases, and was pleased with the result, considering one of the cases a brilliant success. He used a large number of needles, and he made nine to a dozen "prickings," injecting each time three or four drops, if he did not meet with "a too sensitive subject." In all the patients the treatment caused considerable pain, and in one rather alarming general symptoms. She said she felt as if quicksilver were circulating in her blood-vessels. The best result obtained was a considerable amount of cicatrisation in the neoplasm, the area of which, however, ultimately became neuralgic and gave rise to much pain.

It is claimed for the process that it causes cicatrisation, diminishes discharge, and occasionally produces a perfect cure; on the other hand, it is admitted that each repetition of the injections amounts to a painful operation; that these operations must be frequently repeated, and that the result is always uncertain. Vulliet considers the most favourable case the one in which a neuralgic cicatrix remained.

*Suppression of Hemorrhage and Diminution of the Foul Discharge.* — As the disease advances these objects become among the chief concerns of the medical attendant, apart altogether from operative treatment. The one rapidly saps the patient's strength and brings on anæmia; the other poisons her, and makes her an object of distress or disgust to herself and to those about her.

Owing to the irritable condition of the patient's digestive organs and lower alimentary canal, it is necessary to make the most of local measures. One great difficulty in the treatment is the anorexia; and we cannot afford to upset such digestion as there may be by styptic and antiseptic remedies — such as mineral acids, tannin, ergotin, or any of the turpentine series — administered by the mouth.

For the arrest of hæmorrhage we must trust to pressure by a tampon introduced into the vagina, and planted firmly upon the bleeding ulcer-surface. It is usual to supplement the hæmostatic effects of



the pressure by means of a styptic. The great objection to the use of the salts of iron for this purpose is the embarrassing discoloration produced by them. Each of the other known styptics has had its advocates. An endeavour has usually been made to find an agent with deodorising properties in addition to the hæmostatic. The objection to terebene and turpentine, combined with oils or in any other way, is that they produce a certain amount of pain internally and irritation about the external genitals. A weak solution of chloride of zinc, with or without the addition of iodoform, makes a useful material for application; and, among those which I have tried, I know nothing better than a solution of acetate of lead in glycerine, with a small proportion of carbolic acid and morphia added.

When the disease is far advanced beyond the stage of active hæmorrhage, it is the foul discharge and the pain which we have chiefly to consider in our treatment. The discharge, moreover, frequently, produces vulvitis, and dermatitis, inside the thighs and in the groins. We must trust largely to internal sedatives to relieve the distress, but the smell and irritating character of the discharge may be modified by local means—chiefly by the use of the syringe charged with a solution of mercury or carbolic acid. An alkaline solution may be occasionally advantageous for cleansing and soothing, but the great majority of the chemical substances used in solution appear to serve no useful purpose whatever. Copious use of warm water, or weak salt and water, is quite as useful. The whole object of this phase of the treatment is to keep the affected parts as little septic as possible, and to prevent discomfort.

When the stage of the disease is reached at which pain becomes a symptom, it is necessary to begin the administration of sedative drugs; and this part of the treatment may be almost entirely summed up in the administration of morphia in some convenient form; no other drug is to be compared with it in its beneficial effects. Its action may have to be supplemented in some cases by sedatives which have more of a soporific action, but it may be said with entire confidence that there is no substitute for it. In inoperable cases of cancer there can be no reasonable ground for hesitating to give whatsoever doses may be necessary to afford relief from suffering. In some comparatively rare complications, such as pyometra and hæmatometra or concurrent disease of the Fallopian tubes producing spasm, considerable temporary relief may be given by the administration of antipyrin, or the extract of viburnum; but the depressing by-effects of these drugs must be kept constantly in mind. In the distress about the anus and vulva, from pressure in the comparatively late stages, the action of the morphia may be usefully supplemented by the use of an ointment of lanolin containing cocaine, morphia, and tannin. When symptoms of renal complications come on it is still necessary to continue the use of morphia, while other measures are taken on the general principle of giving relief in kidney disease. It is not as a rule possible, even if it were advisable, to put the patient on any regimen dictated by some supposed

advantages in the method of diet. The dietary should be as generous and varied as possible; the main difficulty in dealing with the patient is not to select the food, but to get her to take any. The object to be kept in view is obviously to assist and maintain the nutrition as long as possible, and prevent the inroads made upon the strength by hæmorrhage, septicæmia, and pain. With this object the usually recognised adjuvants to digestion, such as pepsine, peptonised foods, and the like, should be pressed upon the patient.

With regard to the effects of the administration of drugs, throughout the whole course of the case, for purposes other than the relief of pain, our exact knowledge is almost nothing. We know that alcohol in suitable doses produces a certain amount of stimulation and a sense of well-being, and, if it can be well borne and duly eliminated from the system, there does not seem to be any sufficient reason for denying some reasonable amount to those to whom it would be a comfort. It may be considered, in fact, as an auxiliary to morphia and soporific drugs; and, in the latest stages, one of the means of euthanasia.

Arsenic has so long had a reputation in the treatment of cancer, whether internally or by topical application, that we are disposed to administer it rather lest we should be depriving the patient of an advantage than from any firm faith in its usefulness. If it can be borne, the combination of arsenic and iron, either as a pilule of arseniate of iron, or as a natural arsenical water, is probably beneficial. I have been in the habit of recommending the constant use of arseniate of iron to patients after total hysterectomy, and my impression is that a certain amount of advantage has been obtained from it.

Quinine is recommended as a means of diminishing, as far as possible, the effects of absorption from the septic area, but it is not well borne by the stomach of a cancer patient, and in fact it is only in the comparatively early stage that it can be, as a rule, administered with advantage.

The specific treatment by Chian turpentine need only be mentioned in passing as one of the numerous empiric methods of treatment which excited hopes for a time, among some persons to whom a disease is an entity, only to be abandoned like its forerunners in favour.

*As Complication of Pregnancy.* — Malignant disease of the cervix as a complication of pregnancy and labour is a subject of great scientific interest and practical importance. Owing, however, to the comparative infrequency of its occurrence, to the great variations in the clinical facts of the cases, and to the intermixing of ethical considerations of greater or less importance, it is impossible to make a satisfactory classification of the cases, or to lay down any rules of universal application.

When the disease is not far advanced, and it is obvious that the uterus could be extirpated without unusual danger or difficulty, the following question naturally arises with regard to the interruption of pregnancy: — If the pregnancy is not far advanced, are we to wait to the full, or nearly to the full term, and permit the cancer to grow rapidly, as it

is certain to do in the meantime? or are we to interrupt labour without any consideration for the life of the fœtus in utero? With regard to the interruption of pregnancy, which is not effected at the same time as the final operation on account of the cancer, we must keep in mind the great danger of septic infection during the puerperium owing to the manipulations of the malignant new-growth and its continued presence. Another consideration, which must influence to some extent the judgment of those with whom the decision lies, is the prospect of inherited tendency to malignancy in a child developing in the uterus of a mother already the subject of the disease in a more or less advanced stage; even though ordinarily heredity may be almost disregarded as a factor in the etiology of cancer. But there is a stronger argument against giving too much heed to the child in the adoption of any modern method of obstetric treatment. If we compare the results, so far as the child's life is concerned, of the earlier practice in cases of cancerous complications with those obtained since operation has been more largely resorted to, we find that in Cohnstein's statistics, published in 1873, only 42 children survived in 116, that is, 36·2 per cent. In the 142 cases quoted by Theilhaber, in giving the statistics for twenty years up to 1893, the proportion surviving was 46·4 per cent.

Now a large number of these survivors of birth die within the first few weeks: experience, therefore, shows that in any event the danger to the child on the expectant plan of treatment is very great.

If we may infer the opinions from the practice of those who have published cases, one would be led to the conclusion that the life of the fœtus has not been a matter of much concern to most of them, and that operations have been undertaken almost entirely in the interests of the mother. Even the great exception to this rule appears to show that the mother's life and welfare should be our main consideration in deciding the time and method of operation. The great exception is the case in which the disease has not been discovered until towards full term, or when labour has begun. The case has then usually become inoperable as a case of cancer; and the only thing that can be done is to endeavour to save the child by the Cæsarean section, which also enables the mother to live as long as the disease will permit.

The operable cases of cancer of the pregnant uterus readily divide themselves into three largely comprehensive classes. Yet some operable and many inoperable cases can hardly be classified; and a study of the individual case must guide us to what should be done or left undone.

The first class includes all the cases in which the cancer is discovered before the uterus has become so large as to make removal of it, unopened, impossible per vaginam; that is to say, at the latest in the fourth month.

To the second class belong those cases in which the pregnancy is too far advanced for this comparatively simple proceeding: in these cases in order to remove the uterus per vaginam it is necessary first of all to empty it by bringing on premature labour while the child is non-viable. The third class consists of those cases in which the disease is not dis-

covered until the woman is in labour and the child is living; then the alternatives are ordinary obstetric management and the Cæsarean section with complete removal of the uterus.

Cases of the first class present the most favourable features. The malignancy may be developing rapidly, and the amount of hæmorrhage and offensive discharge may be very considerable; but owing to the evolution of the uterus the tissues are remarkably loose, and the process of enucleation thus becomes comparatively easy and safe. It is, in fact, the most favourable method of treatment if the condition be discovered in time. Theilhaber gives a list of eleven cases, including the cases of Olshausen, Greig-Smith, Brennecke, and Kaltenbach, in which total extirpation without opening the uterus was the treatment in early pregnancy without a single fatal result.

When the uterus is too large for vaginal hysterectomy pure and simple, it is necessary first to bring on abortion or to perform the abdominal operation. But the dangers attaching to Freund's combined abdominal and vaginal hysterectomy are too formidable to allow it to be entertained except under unusual circumstances. To empty the uterus adds appreciable risk to the operative proceedings, inasmuch as there is considerable danger of infection. It may be assumed, however, that no one likely to undertake the management of such a case would operate without every possible precaution; or, if septic metritis occurred in spite of such precautions, would allow it to run its fatal course. If, after the exercise of every care to prevent septic infection arising from the induction of labour complicated with ulcerating cancer, and in spite of all precautions, suspicious symptoms arise, there should be no hesitation in proceeding at once to the complete operation of vaginal hysterectomy; but if no untoward symptoms arise the uterus is extirpated at some convenient time during the puerperium. Theilhaber gives a list of three cases in which this method was adopted, and the result was in each case satisfactory. Many other cases, suitable for this method, are mentioned in which unsatisfactory and usually feeble treatment was followed; with the results which might have been expected.

In the third class referred to, when the disease is discovered at or about full term, it is usually far advanced; and, whatever the treatment, the results are unsatisfactory. If the os uteri be dilatable the obstetric method of waiting until the forceps can be applied appears to give the best results for mother and child. In eight cases quoted the mothers all survived, and six of the children were born alive. In five cases where turning was resorted to three mothers died.

Cæsarean section by any of the methods, or combined with Freund's total extirpation operation, gave disappointing results. Eight cases of the old method of Cæsarean section are quoted; all the mothers died. After Sænger's Cæsarean operation, of 13 women only three survived for a month or six weeks; most died directly after the operation. Five out of twelve lived after Porro's operation; and two out of six survived Freund's combined method of total extirpation.



Cohnstein's statistics up to 1873 show that, including all cases, however treated, 72 women died out of 176 — a mortality of 57 per cent. Theilhaber's figures for the last twenty years are 162 patients, of whom 51 died during or immediately after labour — that is, a mortality of 31·5 per cent. A complete study with recent bibliography will be found published by Hernandez in 1894 (32).

**III. Cancer of the Body of the Uterus.** — Cancer of the body of the uterus is a comparatively rare disease, but published accounts of individual cases do not now indicate it as so rare an occurrence as they formerly did. More exact and earlier observation, and the inclusion of diffuse sarcoma and malignant adenoma, as, clinically speaking, cancer of the body of the uterus, greatly increase the number of cases.

The disease under consideration is malignant, and histologically it is carcinoma; but in its clinical features, including its amenability to radical and final surgical treatment, it might almost be considered a different disease from cancer of the vaginal portion and cervix. This difference is all the more striking clinically if we compare primary cancer of the body, which is the only disease under consideration at present, with cancer as found in the body when it is secondary to cancer of the cervix, whether by continuous extension or by inoculation during the manipulations of treatment, which certainly sometimes occurs. The clinical course of secondary cancer of the body is not separable from the course of the primary disease from which it sprung; we shall here concern ourselves with primary cancer only.

At the time of writing his monograph, about ten years ago, Gusserow had collected from all sources only 122 cases of primary cancer of the body of the uterus, including an indefinite number of cases of sarcoma. Schroeder diagnosed 28 cases as primary cancer of the body in 812 cases of carcinoma of the uterus — that is, 3·4 per cent.

Krukenberg gave an account of the radical operations for malignant disease of the uterus done at the University Clinic for Women in Berlin in five years ending with April 1891. Of 24,887 patients, 924 (3·7 per cent) were suffering from malignant disease of the uterus; and of these 292 (31·6 per cent) underwent surgical operation. The operation in 235 cases was total extirpation; and the disease in 197 cases was carcinoma of the cervix, in 30 carcinoma of the body, and in 8 sarcoma of the body. Here, in a large number of cases diagnosed beyond question, we find malignant disease of the body occurring with comparative frequency; the relative frequency to other forms appearing in a much higher proportion than in older statistics.

*Pathological Anatomy.* — Excluding adenoma malignum and diffuse sarcoma of the body, genuine carcinoma corporis uteri occurs in two fairly well defined forms, according as it originates (*a*) in the parenchyma or substance of the uterus, or (*b*) in one or other of the constituent elements of the mucosa. The form originating comparatively deep in the tissues is described as developing nodules or spheroidal masses in the

uterine tissue; these sometimes bulge on the peritoneal surface, sometimes on the mucous surface of the uterine cavity; but they have little tendency to soften within the uterine wall, or to ulcerate on either peritoneal or mucous surface. This form is almost invariably described by writers on the malignant diseases of the uterus, but it must be a rare disease; and some cases which have been observed and subjected to careful examination have not improbably been either sarcoma or some hybrid form.

Cancer of the body of the uterus originating in the mucosa varies in form according as its seat of origin is the utricular glands or the superficial epithelium. The most ordinary case of carcinoma of the body appears to begin in the utricular glands. These glands at the site of origin become blocked by the proliferation of the epithelial elements. This is usually described by the pathologist as the ultimate fact in the initiation of the phenomena of malignant change in the glands, but the anatomist—for example, Symington in *Quain's Anatomy*—describes blocking of the deeper extremities of these glands as a normal condition. Distension of the lumen follows the blocking of the glands, the blood-vessels in the interglandular spaces become obliterated, and occasionally deposits of pigment take place. At a comparatively early stage of this process hardening or nodulation, with a certain amount of projection into the lumen of the uterine canal, occurs; and simultaneously there is development towards the muscular tissue of the uterus. The condition usually met with on examination of the uterus after extirpation is that of an alveolar cancer deeply invading the muscular tissue of the uterus; sometimes with nodules bulging upon the peritoneal surface, and invariably with a certain amount of ulceration towards the uterine cavity. This is the adenocarcinoma described by Pfannenstiel. It is probably thus designated because of a distant resemblance to gland tissue which it assumes, but, as will be shown later, it is not adenoma malignum in the narrower sense. When the cancer begins in the superficial epithelium of the uterine mucosa, with invasion of the deeper tissue, there is also a papillary formation somewhat analogous to the cauliflower excrescence of the vaginal portion of the cervix. It may, however, take the form of mere superficial proliferation with necrosis and ulceration, forming a tumour comparatively late in its development. This is the adeno-carcinoma papillare of Pfannenstiel. Many of the cases described are probably epithelioma just as it occurs in the cervix. These, as Fritsch points out, are mere forms of the development of the disease in different varieties of cancer; and both forms may occur in the same case.

Quite recently, in some of the German special journals, accounts of cases called epithelioma (Hornkrebs) have appeared from time to time. I have recently operated upon a case which cannot well be described, either clinically or histologically, as other than papillary epithelioma of the body of the uterus. Hofmeier describes two cases of pavement-epithelium cancerous tumours of the body. In one the diagnosis was by the curette and microscope, as total extirpation could not be effected; in the other case both a tumour of pavement

epithelial formation and a glandular carcinoma occurred in the same uterus. The patient was a virgin of 50; menopause at 41; hæmorrhage for  $1\frac{1}{2}$  years; last half-year purulent discharge in addition. Vagina narrow; portio short; tumour size of a fist and a half bulging through cervix from cavity of body; curette used for diagnosis. Microscopic examination led to the belief it was sarcoma. Operation by abdominal section and vaginal method combined. Most of the tumour was ultimately found to be alveolar cancer, but part of it was unquestionably pure flat-celled epithelial carcinoma.

Several such cases of epithelioma corporis uteri have been reported in the course of the current year from various quarters.

*Etiology.* — Cancer of the body is comparatively so rare that we have no great volume of statistics to apply to and manipulate in the endeavour to find some clue to the cause of the disease. One thing is certain, that the most striking facts connected with cancer of the body are entirely different from the corresponding points in cancer of the cervix. In cancer of the body the patients are on the average much older; they are in a different position in life, usually much better cared for from beginning to end than the class of women most frequently affected with cervical epithelioma; and whereas the subjects of cervical epithelioma are, with few exceptions, parous, most of them multiparous, many of them remarkably prolific, the subject of corporeal cancer is almost invariably either elderly maiden or barren wife. All my five cases were women past the menopause: two were married, but only one had been pregnant; the rest were unmarried. In the case of the parous patient a hard, localised papillary carcinoma projected from the fundus, and this fact suggests that there is something different in the etiology of such rare tumours from those usually met with in the body of the uterus in elderly women. Relevant to this supposition is, for example, the apparent exception of Chiari's three cases quoted by Gusserow. The patients were married, child-bearing women, in whom the malignant disease made its appearance soon after child-bed. But these cases have since been shown to have been not carcinoma, but deciduoma malignum.

*The symptoms* of cancer of the body of the uterus in its early stages are as constant as the symptoms in the corresponding stage of epithelioma of the cervix. The most constant is hæmorrhage which, in the post-climacteric cases, is characteristic. In cases in which the disease occurs before the menopause, the hæmorrhage at first bears some resemblance to that which is caused by fibromyoma of the uterus. It is often menorrhagia, a profuse and prolonged menstruation, not an ordinary metrorrhagia. Too much, perhaps, has been made of this symptom in the ante-climacteric cases, as the number of cases reported is comparatively small, and generalisation a rather rash proceeding: in differential diagnosis too little has been made of the fact, that fibroids producing hæmorrhage in the immediately ante-climacteric period of life are usually well known to exist, and the cause of the hæmorrhage is consequently known. Besides, such fibroids are almost invariably sufficiently large to settle, without further

consideration, the question of cancer of the body of the uterus. In the great majority of cases the hæmorrhage has recurred after the complete menopause. It is, as a rule, comparatively slight, and at first there is no other symptom at all; there may be lumbar or hypogastric aching from the congested condition of the uterus, and from the reopening of the senile internal os uteri. The hæmorrhage is slight and continuous, and there may or may not be some leucorrhœal discharge between the periods of bleeding. The hæmorrhage often continues for a long time before the patient seeks for medical treatment. In one typical case of alveolar cancer, occurring in a maiden lady of fifty, whom I had under treatment for a considerable time, finally extirpating per vaginam, the menopause had occurred two years before the symptomatic hæmorrhage began; and the hæmorrhage had gone on for twelve months before the patient mentioned the fact to anybody. By this time pain had also become troublesome, and in this relation of the symptoms of hæmorrhage and comparatively early pain we have one of the most marked differences in cancer of the body from cancer of the cervix. When the cancer assumes a form of superficial epithelial change, producing a localised comparatively hard mass acting like a foreign body as in the case to which I have just referred, pain comes comparatively early, and ultimately is acute, it may be agonising: it is also frequently paroxysmal, and this fact, taken with the existence of great hypertrophy of the muscular tissue of the uterus, suggests that pain is caused by an effort of the uterus to shed or expel the diseased endometrium like a foreign body.

Another fact in support of this view of the cause of the pain, is that in such cases the os uteri is thinned out as in the case of submucous fibromyoma approaching the state of polypus; and the cervical canal is comparatively wide.

In cases of another class pain may be trifling or almost absent to a comparatively late stage of the development of the disease. This fact was well illustrated in two cases in which I removed the uterus during the last twelve months. One was a typical case of adenoma malignum, in which, after repeated curettings, the disease had destroyed the endometrium, and at the time of extirpation had left little but a tolerably thick layer of muscular tissue. In the other case, from a site of origin probably in the utricular glands, comparatively rapid ulceration had advanced, until little of the original structure of the uterus was left except a thin layer of muscular tissue and the comparatively soft peritoneal covering. There was no hardness or nodulation in either case; and the steady uniform necrosis, with free exit for the liquefied tissue, appeared to have some causal relation to the immunity from pain.

Even in the later stages of malignant disease of the body of the uterus, there is no pain analogous to that which arises, in cancer of the vaginal portion and cervix, from infiltration of the parametrium and interference with the neighbouring organs, especially with the urinary organs. The pain in the later stages is not from pressure, but from



peritonitis. In the first case to which reference has been made the peritonitic pain was extremely well marked after paroxysmal pain had disappeared under treatment; and on extirpation it was found that a considerable quantity of fluid, which was turbid and contained shreds of lymph, had collected in Douglas' space; and bosses of cancerous material were found bulging in various positions upon the peritoneal surface.

Another point with regard to the pain of cancer of the body, when it does occur, is that after the first hæmorrhage there is no symptom analogous to the distress from tension produced by pyometra, which, by closure of the internal os, is so often a complication of epithelioma of the cervix uteri. "The intense agonising pain at an early stage of the disease," of which Gusserow speaks, appears to be symptomatic only of circumscribed adeno-carcinoma of the body.

Another constant symptom of cancer of the body of the uterus is a discharge — not hæmorrhagic or sanguineous. As compared with cancer of the cervix, however, this symptom comes on comparatively late, and the discharge is different. It is different in being thinner and less turbid; and, although fœtid, it is usually much less offensive. The absence of the intensely offensive odour of cancer of the cervix is probably due to the absence of infection by bacteria. It is, perhaps, also on account of the comparatively late occurrence of infection of the ulcerating surface that sapræmic symptoms, with emaciation and cachexia, are comparatively late in appearing in a case of cancer of the body. In all the cases which I have seen, the least developed of which was twelve months from the beginning of the hæmorrhage, the aspect was that of anæmia, not of cachexia; and in the last case of all, although the hæmorrhage had continued at intervals for over a year, there was no appreciable loss of flesh. Emaciation comes after the anæmia, after the slight feverishness of the sapræmia; and the loss of rest ensues on the beginning of pain, the use of drugs, and the unexplained influence upon the digestive organs of malignant disease anywhere in the body.

The other symptoms and complications arising from cancer of the body are late in appearing. Metastases do not readily occur; and even infection of the lymphatics, after repeated curettings and interferences with the uterus, is strangely slow in appearing. With the invasion of the lymphatics in uterine cancer comes the reaction of the connective tissue invasion which produces fixation of the uterus; and in the absence of lymphatic infection in cancer of the body is probably to be found the explanation of the fact, that in cancer of the body the uterus is seldom if ever found to be fixed until a very advanced stage of the disease is reached.

My first case of extirpation of the uterus well illustrates the extent to which local and general changes may occur, and the length of time which may be occupied by these changes without lymphatic invasion or metastases; so that the capacity for full recovery still remains. After repeated curettings, the administration of drugs, and frequent hæmorrhage and foul discharge during an unnecessary delay of twelve months, which was owing to the decided diagnosis of sloughing fibroid made by

a well-known gynæcologist, my patient had reached a point of emaciation and suffering from agonising pain in the uterus, and disgust produced by the foul discharge, which no general or local medication seemed to relieve: thus the only alternatives became euthanasia or total extirpation. The operation was performed eight years ago, dating to the time of writing, and within a week an entire change had come over the patient. She was free from pain, had escaped all the misery of pervading malodour, and had begun to take food. Since the time of complete convalescence from her operation she has, I have reason to believe, required no medical treatment of any kind; and she is perfectly well at the present time.

Considering the amount of uterine peritonitis in this case, and the softness of the bosses on the peritoneal surface of the uterus, it is pretty certain that if the patient had been left untreated a short time longer death would have occurred from peritonitis, as has sometimes been the case, though wonderfully rarely.

*Diagnosis.*—In a case of cancer of the body, after the completion of the menopause, there should be comparatively little difficulty in establishing a diagnosis. It may be difficult or impossible to say what form of malignant disease exists; but the diagnosis of malignancy should not be difficult, and this is sufficient for all practical purposes. The particular form of malignant disease is seldom diagnosable from the symptoms and from the examination of shreds of endometrium; and, when the extirpated uterus is in the hands of the pathologist, it is sometimes even still a matter of doubt. When malignant disease of the body occurs before the menopause, there are only two other conditions or combinations of these which can produce symptoms likely to lead a well-informed practitioner into difficulty: these are necrosing fibroid polypus or subserous fibromyomatous tumour, and incomplete early abortion with slight bacterial infection.

In the case of cancer of the body, the cervix on digital examination gives, as a rule, the impression of being unchanged. The lips may be thinned out in cases of the class already referred to; but as a rule no such change has taken place. It is stated also, by some authors, that the exposure of the vaginal portion by the speculum does not assist the diagnosis. In the cases which have come under my observation there has always been a change in the endometrium, even of the vaginal portion. There is a suggestion of activity and hyperæmia, an indescribable change of colour of an unwholesome kind. It is a hyperæmia confined to the mucous lining without any other obvious change; and this change of colour and consistency is seen in an extremely marked form even after total extirpation of the uterus. On physical examination, per vaginam and bimanually, the uterus may not be found greatly changed in size or shape. In old virgins the examination should be invariably made with the aid of an anæsthetic; and then it will be almost certainly found that the changes ascertainable by palpation are sufficiently marked to arrest attention. Some slight departure from the normal symmetry of the organ, a greater or less departure from homogeneity in the resistance to pressure, hardness,

softness, or elasticity, are signs which must receive attention, and to which due weight must be attached in the diagnosis.

When the diagnosis of marked disease brings up the question of such a serious operation as total extirpation, there is much to be said for complete exploration by dilatation so as to permit the entrance of the index finger into the cavity; but this proceeding, not without danger in the senile, is apt to produce metritis or endometritis or peritonitis which may greatly embarrass the operation and make it more dangerous. Such manipulations are also undesirable on account of the ever present risk of producing sudden activity of the malignant process, which, after the production of a wound, might possibly result in lymphatic infection or in some other local infection by contact.

Rapid dilatation, it may be with the aid of an anæsthetic, and the use of the sharp curette or spoon, should make a final and definite diagnosis possible at once. There is nothing else in nature like the shreds thus obtained in a genuine case of malignant disease. It may be objected that the broken-down tissue of a sloughing fibroid is extremely like the tissue of a spindle-celled sarcoma. This is one of the cases in which assistance in diagnosis may be obtained by comparatively slight and easy microscopic examination. If any doubt can possibly exist, the differences revealed by the microscope are so obvious that any further difficulty becomes hardly conceivable; especially as there is always the history of the case to guide the judgment. With a definite history, such as may be obtained in cases of post-climacteric activity in the uterus, neither dilatation nor curetting may be necessary to a diagnosis justifying operation. The use of the uterine sound or, better still, of a long surgical probe, gives the impression of either roughness and irregularity, or of irregularity and friability in the body of the uterus that has no parallel in uterine disease. The probe, even when used in the gentlest fashion, is perceived to sink into the friable tissue, and such trifling manipulation is followed by an altogether disproportionate amount of hæmorrhage.

The differential diagnosis of ante-climacteric cases from fibroid tumour, or retained portions of early blighted ovum, may be worth consideration; although, a short period of observation being granted for the purpose of diagnosis, any important difficulty is hardly conceivable. In the case of blighted ovum there must be something in the circumstances implying the possibility of pregnancy, and a history of symptoms suggesting occurrence of pregnancy. Even with an offensive discharge, the appearance of the uterus when exposed by the speculum and volsella is altogether different from that which contains a malignant tumour; the physiological as contrasted with the pathological colour of the mucosa is unmistakable; and, finally, dilatation permitting the use of the curette must at once dissipate any doubt as to the nature of the condition: a tumour, however friable, is attached; a retained portion of ovum is free to come away on slight handling.

In the case of sloughing fibroid in a woman before the menopause, the circumstances may be such as to make the diagnosis doubtful until part



of the tissue is examined; but this must be a very rare occurrence. The hæmorrhage in the case of the fibroid is profuse menorrhagia; the intermenstrual discharge, if the patient have undergone no treatment, is hydroorrhœa, not a malodorous, turbid, sanious, or dirty water discharge. However anæmic the patient may be from the loss by hæmorrhage and discharge, the cervix, as revealed by the speculum, will give the impression of health.

In the case of the fibroid subserous tumour or polypus, the cervix will be comparatively soft, and the cervical canal more or less dilated. If any doubt continue to exist, dilatation to permit of digital examination may have to be effected, and some portion of the tissue removed. The only possible smooth, circumscribed tumour which can simulate fibromyoma is sarcoma; and an easy, rapid, microscopical examination of even a particle of the débris of tissue should finally settle the question. But no such question need arise. The naked-eye appearances of the two tumours are distinct: the sloughing fibroid, even when blackened in colour, is not so easily torn; and when torn it still shows the fibrous structure in the shreds: the malignant tumour, like all malignant tissue in the uterus, if not soft, is always friable, and is thus easy to distinguish from any possible form of fibromyoma in any condition which it ever assumes.

*The prognosis* in cancer of the body of the uterus is much more favourable than in malignant disease of any other portion of that organ. It is long after the initial stages of the disease that lymphatic infection occurs; and consequently fixation or even embarrassment of the movements of the uterus is an incident of an advanced stage only. This long continuance of mobility greatly favours surgical treatment; and, as a matter of experience, comparatively few cases of this affection come into the hands of the gynæcologists in an inoperable condition. Krukenberg found 63·2 per cent of cases of cancer of the body still suitable for operation. The risk of operation is said by some to be greater, for example by Mangiagalli on a very limited experience; but the prospects of the patient who has recovered are immeasurably more hopeful than after recovery from the same operation for cancer of the vaginal portion.

An important source of danger in the course of the operation—one which, perhaps, may not be sufficiently guarded against—is that of infection of the vaginal or of the peritoneal wound. In many of the cases of recurrence after cancer of the body the disease could be distinctly traced to contact infection.

Krukenberg's report in the paper already referred to shows the favourable prospects after extirpation for cancer of the body in a very striking way.

Of 26 patients there were free from recurrence after one year 18 (69·2 per cent); of 16, after two years, 13 (81·2 per cent); of 13, after three years, 9 (69·2 per cent); of 11, after four years, 7 (63·6 per cent); of 5, after five years, 4 (66·7 per cent). The results would probably have appeared better still if information concerning the missing patients had been obtained.

Hofmeier mentions one case of Schroeder's in which no relapse had



occurred after fifteen years. He gives also the history and results of 23 cases of operation of his own. In 4 it was necessary to perform the abdominal operation on account of the size of the uterus or of complications; and the patients all died in from two to eight days. Of the 19 operated on per vaginam only one died from the operation, and Hofmeier states that this was the only death in his last 60 cases of vaginal extirpation. In two of the surviving cases, in which the disease was of long standing at the time of operation, a recurrence took place in the first year, and one died suddenly from some unknown cause; all the rest were well at the time of the report, thus implying from one to eight years of immunity from the disease after operation.

*Treatment.*—When cancer of the body of the uterus is diagnosed before fixation has occurred, or before complications and lymphatic infection have made operation useless, there is only one method of treatment to be considered; that is, total extirpation per vaginam.

The experience of every year gives greater confidence to the advocates of this method of treatment. The technique of the operation continues to improve, and all experienced operators bear testimony to the smallness of the immediate risk to life and the excellent prospects of perpetual immunity.

Much harm is frequently done by temporising and meddling in an ineffectual way. There is in too many cases a history of medical treatment without examination; but it must be admitted that it requires faith and consciousness of knowledge to insist upon an early physical examination in the case of an elderly maiden lady.

Again we learn that the curette has been used, and something applied, and that the symptoms to some extent improved; this merely implies in all probability that the hæmorrhage temporarily disappeared, and thus still further time was lost.

In cases of this class my impression is that the practitioner is too shy of hinting at cancer, which idea after all has probably taken possession of the patient's own mind already.

After the least possible amount of manipulation consistent with forming a confident diagnosis, the operation of total extirpation should be performed without delay.

With regard to the operation there is little to be said that does not apply to the same operation for any other condition. One danger to be avoided is to prevent contact infection and consequent early recurrence from extravasation of the cancerous fluid. In portio cancer you may use the curette or scissors as the first step in the operation; the analogous step in corporeal cancer is to suture the external os so as to prevent any fluid from escaping.

A difficulty frequently arises from the senile condition of the vagina and parts generally. So difficult is the operation sometimes made by the narrowness of the vagina in an elderly maiden that it is possible to complete it only by making a free deep incision through the perineum. Retractors which, without considerably lacerating the parts, will stretch them to the uttermost, are also essential.

On account of this difficulty many operators have recommended the sacral operation, and probably still more the combined vaginal and abdominal method. We have seen, however, how terribly fatal Freund's operation is in even the best hands, and the drawbacks of the sacral method are too serious to justify it save under very exceptional circumstances. I do not regard the difficulty of a narrow vagina and senile change as so great as it has been sometimes represented. No operation of the kind could hardly appear more formidable than one which I performed recently on a virgin of over 60 years; but my first step was to make a free incision in the middle line of the vagina from an inch below the uterus right down and through the perineum to the sphincter. The last step was to stitch up this wound, and it healed perfectly without reaction or flaw.

In a far advanced case, when radical operation is out of the question, the methods of giving relief are exactly those employed in inoperable cancer of the vaginal portion and cervix. The prospect of keeping the patient fairly comfortable is moderately good. Hæmorrhage can be kept within bounds by means of the curette and tampon. The danger here is rather uræmia than septicæmia: it is the blood-poisoning and accompanying fever which saps the strength. Hence the need for every effort to keep the area affected as nearly aseptic as can be managed.

The complications of the later stages of cancer of the body differ considerably in an anatomical sense from those produced by disease beginning in the cervix; but the symptoms are practically identical, and the methods of giving relief from sufferings are the same.

**IV. Sarcoma.** — Sarcoma is a comparatively rare form of malignant disease of the uterus. Still it occurs sufficiently often to make it a matter of importance to the practical gynæcologist; it is not a mere matter of scientific interest to the pathologist. Sarcoma may occur at any period of the sexual life of the woman over 20 years of age; but like carcinoma it is found comparatively often in the years just before or just after the menopause. It may be accidentally met with during the climacteric period also.

Three (34) well-defined forms of sarcoma of the corpus uteri only will be described and treated of here. The first is the form, occurring in tumours or masses, which is so often mistaken for fibromyoma of the uterus; the second is the diffuse form found, in its earlier stages, in or near the endometrium, and bearing a strong resemblance in its clinical aspect to carcinoma of the body of the uterus. The third is sarcoma botryoides, which calls for little notice.

The development of the first variety has a striking resemblance to the growth of fibromyoma; and, in fact, all the details in the study of it are closely analogous to those of fibromyoma.

A woman who is approaching the climacteric period of life knows or suspects she has a tumour of the womb. She is led to look forward to abatement of her symptoms and diminution or disappearance of the

tumour with the cessation of menstruation. Instead, however, of her hopes and expectations being fulfilled the tumour, which may have been almost or altogether stationary, begins to grow, the hæmorrhage increases and becomes irregular, or it is replaced in time by a thin, watery, sanious discharge. The fibromatous tumour, which has been painless, begins to cause uneasiness, and ultimately gives rise to intolerable pain. The patient takes on an aspect of suffering and deterioration of health not sufficiently accounted for by the anæmia owing to the discharge; she gradually loses flesh and assumes a cachectic appearance. When examined after some weeks or months of medical routine treatment the uterus is found to be fixed, and the floor of the pelvis has the stony hardness of the middle stage of perimetritis. The infiltration of the tissues of the broad ligament affects the ureters and kidneys in the same way as in the corresponding stage of cancer of the cervix, and the termination may be the same; or symptoms owing to metastases in distant organs may arise, and the fatal termination come rapidly.

These are the chief facts in the history of a case of fibrosarcoma uteri, the form of the disease which is due to the transformation of fibromyoma into sarcoma. It is, I believe, by far the most common of the forms of sarcoma of the uterus, although some regard the diffuse form as the most frequent.

The second form of sarcoma of the body, as usually described, closely resembles the diffuse form of carcinoma of the uterine mucosa; and it is only to be clearly distinguished from carcinoma by the microscope. And in some cases there has even been a difference of opinion among competent clinicians and histologists as to the exact nature of the neoplasm, with the clinical symptoms and the microscopic appearances of removed tissues in evidence. In some of these cases there has probably been some intermediate condition between carcinoma and sarcoma.

A variety of this form is cystic sarcoma, of which a considerable number of cases have been described by competent observers. This is, pathologically, merely a cystic conformation of the interstitial variety, or myoma sarcomatodes; but it has sufficiently special clinical features almost to require a separate classification and description for the efficient exposition of its characters, their origin, and their practical consequences.

Many cases of sarcoma of the body of the uterus have been described as exhibiting such individual peculiarities that it would not be possible to reduce them to any classification which could serve a useful purpose. We must rest satisfied with describing all that pertains to the individual case.

The same remark applies to sarcoma of the cervix. It is a comparatively rare disease, and the anatomical situation is the only thing sufficiently in common to serve as the nexus for any clinical account of the individual cases. The most striking form occurring in the cervix is the sarcoma botryoides or grape-cluster tumour met with not only in children, but at any later period of life.

*Pathological Anatomy.*—A. The interstitial form of sarcoma is analogous in structure to the fibromyoma of the uterus as it is fre-



quently, perhaps always, a transformation of the common benign tumour. Some of the cases described, even when definite tumour masses existed, appear to have been soft sarcoma derived from the endometrium. As a rule, the new growth consists of one or more circumscribed masses, not to be distinguished by form or consistency from myoma. They are probably the "œdematous tumours" which gynæcological surgeons remark on as uninfluenced in their growth by castration. Histologically they show a proliferation of round cells, more or less replacing the normal tissues of the uterine wall. From Virchow and Schroeder to the present time the vast weight of authority has been in favour of the view that interstitial sarcoma is a malignant transformation or degeneration of the ordinary fibromyoma; and many sarcomatous tumours have been described which exhibited marked traces of their origin. It would be superfluous to quote authorities or describe even typical cases to substantiate and illustrate that which all recognise and accept.

Von Kahliden, in an important contribution on sarcoma, while supporting the usually accepted opinion of the origin of the disease, mentions a case in which the seat of origin of the tumour was in the blood-vessels, the result being a well-marked angio-sarcoma.

An attempt has been recently made to prove from the histological examination of operation material that sarcomatous tumours may arise from the muscular tissue elements of the uterus. Dr. Whitridge Williams has published a paper, highly valuable in many other respects, in which he describes a case under the designation of sarcoma-like myoma of the uterus (*myoma sarcomatodes uteri*). The patient was a nulliparous woman of 47, who had passed the menopause four years. A few weeks before admission to the hospital she began to show marked emaciation and œdema of the abdominal walls and lower extremities. The abdomen was filled with "large tumour masses which were diagnosed as malignant growths arising from the generative tract." The patient died without surgical treatment. A detailed description is given of the macroscopic appearance of the tumour, and of the results of histological investigation. Williams came to the conclusion that the new growth was derived from a proliferation of the muscle cells, and not from the connective tissue. After quoting some questionable authority, he proceeds to say, "It is evident that fibromyomata may be transformed into sarcomata either by the proliferation of the connective tissue cells between the muscle bundles, or by the proliferation of the muscle cells themselves."

Unfortunately this statement promises to lead to discoveries too frequently made in gynæcological pathology. Such observations do not long remain isolated. Dührssen, for example, describes a case of submucous fibrosarcoma in which he extirpated the uterus. The tumour presented a marrow-like appearance, and where it bulged out in the uterine cavity it was studded with knobs which on section simulated brain substance. It could be shelled out of its bed, and was enclosed in a capsule of which, by careful manipulation, considerable portions could be



peeled off. The principal mass of the tumour proved to be a round-celled sarcoma in which traces of smooth muscular tissue could still be made out. The presence of a capsule and the remains of muscular tissue removed all doubt. The tumour was originally a simple myoma which had undergone malignant degeneration four years after the menopause. This tumour formed the material for the observations embodied in a laborious work by Pick, in which he endeavoured, among other things, to prove the muscular origin of sarcoma of the corpus uteri.

Pure spindle-celled sarcomas also occur. These when they soften and disintegrate, shedding their débris through the uterine canal, give rise to symptoms which closely simulate those of sloughing fibromyoma.

The analogy to fibromyoma still holds, even with regard to pedunculated tumours. These also have been found undergoing sarcomatous transformation.

Whether such tumours may have also a capsule like a circumscribed fibroma used to be a disputed question. So many cases have, however, been observed by competent clinicians and pathologists in the transition stages, that it may be stated as a fact beyond further discussion, that even malignant tumours of the body of the uterus may have a distinct capsule, and may to this extent correspond still further in structure with the benign tumours.

B. Diffuse sarcoma of the corporeal mucosa resembles, as has been said, the typical form of carcinoma of the same structure. "The term diffuse sarcoma, sarcoma of the uterine mucous membrane, has been used since Virchow's time to designate a new growth proceeding from the connective tissue of the uterine mucous membrane, consisting mostly of small, closely-packed, round cells, though sometimes of spindle-cells, and constituting an exceedingly soft, friable infiltration of the mucous membrane" (15).

C. The third definite form of sarcoma of the uterus, sarcoma botryoides, or grape-like sarcoma, affects the cervix and occurs in the years just after puberty or after the menopause. A few cases which may be included in this class have been described as sarcoma of the corpus uteri. The first case appears to have been reported by Spiegelberg in 1872. A considerable number of cases were described, and the pathology was discussed during the next twenty years, and various names were suggested, until Pfannenstiel published his monograph in 1892, and proposed the term "das traubige Sarcom," or grape-like sarcoma. He opposed the view that the disease was a myxoma, and accepted Weigert's explanation of the histological appearances, which indeed in its essential points may be considered as established. The cyst-like masses, resembling hydatid mole, consisted chiefly of large round and spindle cells with clear spaces separating them. These spaces were traversed by a network of fine thread-like tissue and blood-vessels, and were filled with lymph corpuscles. The new growth was œdematous, not myxomatous; and its attenuated enclosing structure consisted of squamous epithelium, which was covered by a layer of cylindrical cells with indistinct cilia.

The cavities containing lymphatic fluid were not lined with epithelium, and therefore not glandular. The growth in Pfannenstiel's case took its origin from the superficial parts of the mucosa of the cervix, and derived its peculiar conformation from the papillary structures at its site of origin. The ultimate fact in its origin appeared to be some change producing proliferation in the lymphatics and blood-vessels.

Perhaps the most important of recent contributions to this subject is that of Pick, whose conclusions may be shortly stated.

Sarcoma botryoides, as observed in the cervix uteri of adult women and children, and the vagina of children, is in every respect a special variety of tumour characterised by its grape-like form. Clinically it is extremely malignant. Anatomically it develops from the most superficial layer of the mucous membrane; it spreads first in the superficial portions of the mucosa; it shows a strong tendency to invade the deeper tissues; and it assumes the grape-like form owing to the freedom with which it may expand and become œdematous in the wide cavity of the vagina.

The extreme rapidity of development of this form of sarcoma is accounted for by its greater virulence and the rapid circulation of the lymphatic stream in the subepithelial layers. The grape-like conformation is explained by the original papillary development, the freedom for expansion, and the dropsical condition brought about by interference with the blood and lymphatic circulation at the neck of each individual papillary element.

*Symptoms and Course.* — As compared with carcinoma, it may be said that all the forms of sarcoma run a more rapid course than the corresponding carcinomata, after the symptoms first attract attention.

It would be useless to attempt to separate the various forms in any general description of the symptoms produced; indeed it is not possible to establish exact diagnostic symptoms marking them off from carcinomata, for whatever suspicions may be aroused and surmises made, the differential diagnosis is only established by means of the microscope, after operation or death.

The fibrosarcoma gives rise at first to the same symptoms as the fibromyoma. It is only when a tumour begins to grow rapidly at the time it ought to diminish that the suspicion of malignancy is excited. It may be laid down as a rule, with few if any exceptions, that an apparent fibromyoma, which begins to grow at the menopause, is undergoing sarcomatous transformation. The apparent exception, a case of activity, not of enlargement, in a post-climacteric uterus which is the seat of tumour, is the separation of a submucous fibromyoma which has undergone a certain amount of shrinking, and has become starved by interference with its nutrition due to senile changes.

When post-climacteric growth of the tumour occurs two symptoms soon appear. One is pain owing to tension resulting from the rapid growth, and often from invasion of the circumuterine connective tissue; the other is marked deterioration in the general health. Quite recently

I performed abdominal hysterectomy on a patient suffering extremely from pressure symptoms, owing to jamming of a large uterine tumour in the pelvis. The case had been erroneously diagnosed as sarcoma, although the patient had not reached the menopause. I operated for fibromyoma, although it would be difficult to state explicitly the grounds for confidence in that diagnosis, apart from the aspect and the absence of marked deterioration of health. We may observe distinct anæmia from bleeding fibroid, but there is more than anæmia in the case of fibromyoma sarcomatosum: there is an aspect, accompanied by marked loss of strength, which the patient takes on early; the expression of suffering comes later. A few years ago I was consulted in the case of an unmarried woman of the post-climacteric age who, until a week or two before, had been undergoing the electric treatment for fibroid tumour. The pelvis was filled by a hard, irregular mass, and the uterus was absolutely immovable. The history of tumour had existed for years. There was profuse hæmorrhage and much pain, but no offensive discharge. From the appearance of deterioration of health, including loss of flesh, the diagnosis of rapidly growing sarcoma was given, and, after the patient's death, which occurred a few weeks later, this opinion was proved to be correct.

If the neoplasm is developing from a submucous fibromyoma or polypus, there will be severe hæmorrhage and pain from the efforts of the uterus to expel the tumour. If such a tumour be removed there is soon recurrence; but the expulsion of several polypi at intervals, although suspicious, is not to be considered diagnostic of malignancy. "Recurrent fibroid," and therefore malignant it may be; but it may be, and in the preclimacteric case more probably is, merely expulsion of several previously existing submucous fibroids which have shrunk on account of senile changes.

As the sarcomatous neoplasm advances in growth, in addition to occasional violent hæmorrhage, it may cause a sanious hydrorrhœa; even though it is not necrosed. This discharge sooner or later takes on an offensive odour. The tumour, moreover, may become gangrenous, and give rise to septicæmia more or less acute, according as surgical treatment has been attempted or not.

Owing to the intense anæmia, sapræmia, and marasmus, death is readily produced by peritonitis or obstruction of the intestines; or from pressure on the ureters. It is often preceded by œdema of the abdominal walls and legs, partly from pressure, partly from failure of the heart.

In the diffuse mucous form of sarcoma the symptoms are not distinguishable from carcinoma affecting the same structures. There is usually a profuse leucorrhœa occasionally mixed with blood; and severe hæmorrhage may occur, but not as a rule. It is rather persistent and irregular.

Pain as a symptom is variable. It is as a rule more severe than in the corresponding stage of any other form of malignant disease of the body, but cases have been mentioned in which it was entirely absent. The pain probably depends upon several causes. It may be, as suggested

by Gusserow, that it depends upon the depth to which the sarcomatous infiltration has penetrated, and that the immediate cause is "some morbid change in the terminal nerve filaments." From the frequency with which the os internum is partially or wholly blocked from within by the infiltration resulting occasionally in hydrometra or pyometra, the pain must be sometimes owing to efforts of the uterus to expel its contents. It is then partly a uterine colic.

Later in the course of the disease the peritoneum may become invaded, or the disease may penetrate the walls of some of the neighbouring organs.

Metastases are rarer than in the fibrosarcomata, but the diffuse mucous form extends continuously at a greater rate.

*Diagnosis.*—With the exception of the rare sarcoma botryoides of the cervix, sarcoma cannot be positively diagnosed without microscopic examination.

The first thing to be done is to observe the clinical symptoms carefully, and endeavour to settle the question of malignancy. If the malignant character of the tissue-changes in the uterus be once definitely established and acted upon, there will be time to distinguish by suitable means the particular kind of tumour from all others which it simulates.

In the case of the fibromyomatous sarcoma there are two points specially deserving attention: (*a*) the rapid growth at or about the menopause of a tumour previously known to exist, and (*b*) a more marked anæmia and deterioration of health than is ever found associated with the same stage of growth of a benign tumour.

The growth of the tumour may be so rapid as to suggest the French designation *grossesse cancéreuse* sometimes applied to such cases; and, however smooth and symmetrical the tumour, the early occurrence of fixation, as compared with cancer, is a point of some diagnostic value.

The profuse sero-sanguinolent discharge, like hydrorrhœa from sloughing fibroid but usually more turbid even before interference, may excite suspicion. The greater or less density or softness or sense of resistance conveyed on palpation of the tumour does not afford any help to diagnosis.

Attempts to diagnose the mucous form at a comparatively early stage by means of scrapings for microscopic examination have strikingly failed. It will be remembered that when arguments for and against total extirpation were being eagerly sought for in the early days of the controversy, Abel and Landau discovered that the endometrium of a uterus affected by malignant disease, even of the vaginal portion, was the seat of sarcomatous degeneration. The discovery was hailed as important, and its truth was supported by numerous observations. It is now, however, universally admitted that the appearances described are due to changes resulting from congestion of the endometrium, and that similar changes occur in the corporeal mucosa of the fibroid uterus.

*Prognosis.*—There is a remarkable difference of opinion among



writers on the subject as to the comparative unfavourableness of the prognosis in sarcoma and in carcinoma.

All are agreed as to sarcoma that it is malignant; no patient once affected ever recovers.

It is said by some to be slower in its development in the earlier stages than carcinoma, and when treated by early operation to be less likely to recur than carcinoma. V. Winckel commits himself to this opinion, but adds that if operation be impossible the disease is generally more rapidly fatal than carcinoma. This implies that the later stages of inoperable sarcoma are more rapid than in carcinoma, although the earlier development is slower. Reports of individual cases do not seem quite to support this symmetrical generalisation.

Most are agreed that if surgical interference is once begun, the downward course is rapid if the uterus and affected area be not completely swept away. The reported exceptions are comparatively few, although some of them are striking. In recent years, when much attention has been devoted to radical surgical measures, a tolerable consensus of opinion has been formed to the effect that sarcoma recurs sooner than carcinoma after extirpation.

*Treatment of Sarcoma.*—The treatment is radical or symptomatic. The radical treatment is the same as for carcinoma. If the uterus be movable, and there be no metastases or invasion of the vagina, the treatment is total extirpation. This should be done by the vaginal method if possible; if this be impracticable, then by the combined abdominal and vaginal methods. If there be infiltration of the sacro-uterine folds or broad ligaments, even though extirpation is still possible, the advantages obtained in operating at so late a period in carcinoma are not to be expected. Recurrence takes place all the sooner, and the progress of the disease afterwards is so much the more rapid.

**V. Adenoma Malignum.**—The question whether adenoma malignum should be considered a distinct class of cancer of the uterus is not yet settled. Such observations as have been published tend to the conclusion that it is a definite form of disease; just as epithelioma is a definite form of malignant disease of the cervix: and the separate study and description of it would more rapidly bring about its elucidation and more effective treatment.

It is a post-climacteric form of malignant disease almost restricted to the body of the uterus. It is too early in the history of the subject to generalise, but it may be safer and more useful in practice to assume that adenoma occurring in the body of the post-climacteric uterus is always a malignant disease, and ought to be treated as such.

Take as an illustration the case of a patient, age 57, married twenty-six years; never pregnant; menopause in her 49th year. For several years a history of slight discharge without colour and without offensive odour. The family doctor, several years ago, removed a small bunch of slimy polypi that projected from the os uteri; after which there was some diminution in the discharge. In 1893, the discharge had become

so profuse that the patient again consulted her doctor. There was slight occasional hæmorrhage also, though the amount of bleeding was never an important feature among the symptoms. The doctor sent her to consult a well-known gynæcologist, who spoke of some important operation, and on the patient's return home the uterus was dilated and curetted, some more polypi being removed. After this operation the discharge never ceased, and it was sometimes very profuse. After several months of "convalescence" at the sea-side she returned home much worse in health, and I had the opportunity of examining her soon after. The discharge had usually been thin and somewhat slimy, and only quite recently had it become at all offensive in smell.

From the history obtained at the first interview, and the character of the discharge (to the touch it felt like thin ovarian tumour fluid), I concluded that it was a case of malignant disease of the body of the uterus, and total extirpation was suggested. Before operation, however, a much better opportunity of examining the patient was obtained; and, although, on superficial observation, the cervix uteri appeared intact and healthy, there was a peculiar dark coloured, velvety condition of the endometrium of the cervix: on passing a surgical probe cautiously through the os internum the body was found to be enlarged, and the probe could be felt to penetrate the tissues round the cavity. The operation, which was extremely difficult owing to the narrowness of the vagina, was accordingly performed in November 1894, and a year later the patient was described as having been completely restored to health.

Microscopic examination of the uterus showed the muscular tissue penetrated everywhere—in some parts almost to the peritoneal covering; but in considerable patches near the cavity, where the neoplasm had not completely ulcerated, the characteristic glandular appearance of malignant adenoma could be very definitely made out.

The first case of adenoma of the body of the uterus was described by Matthews Duncan, and is quoted in full by Sir John Williams in his work. The chief points to be noted are: the patient, a virgin; her age, 52; previous length of illness, two years; and some uterine symptoms. There is a history of previous good health; then a copious red, watery discharge; later, hæmorrhage and the passing of fleshy pieces; the discharge continued without intermission and was not fœtid. There was pain in the back, then irregularly severe pain in the abdomen, and still later great deterioration of the general health. Then follows a description of the condition of the uterus, the naked-eye appearance of the growth, and the method of treatment; and then the author expresses the opinion that "it will, before many months are past, show the terrible characters of undoubted cancer." This prediction was soon fulfilled. The microscopic appearance was obscured by hæmorrhage into the tissues of the parts removed, but it showed canals lined with a continuous stratum of cylindrical epithelium. Other details are given, such as we read in more recent observations made in material obtained by extirpation, and therefore more favourable for examination.

We have little definite knowledge about adenoma malignum as distinguished from carcinoma of the body of the uterus. It could hardly be otherwise. Our knowledge of cancer as affecting the body of the uterus does not extend back much more than twenty years, when its very existence as a primary disease was still a subject of controversy.

The material obtained by hysterectomy enabled Ruge and Veit (40) to produce their celebrated essay on cancer of the uterus, based on exact clinical and anatomical observations of twenty-one cases. Since then vast additions have been made to the literature of the subject, and more exact observations show that cancer of the body is of more common occurrence than was formerly supposed. Sir John Williams, at the time his work was published in 1888, had seen only seven cases in all his experience; whilst Schmidt (46), in the most recent account of work in a German clinic, gives nine cases of cancer of the body, including two of sarcomatous degeneration of myoma out of a total of 39.

How many of the cases described as cancer of the body were malignant adenoma it is impossible to say, as very few observers have given sufficiently exact descriptions of the histology; and those who have observed and described exactly are divided in opinion as to the proper term to apply to it—whether malignant adenoma or adeno-carcinoma. By its symptoms it has not been differentiated from cancer of the body, although some of its characters are sufficiently well marked.

Ruge (42) maintains that the benign form is a mere product of inflammation; it is an endometritis glandularis hypertrophica, whilst the malignant form is closely related both clinically and anatomically to carcinoma. Ziegler calls it adenoma destruens, but ranks it among the carcinomata.

Fürst described a case of adenoma of the cervix, which was treated by the curette and Pacquelin's cautery. In a year and a half afterwards carcinoma of the body of the uterus had developed itself. He compared the simple glandular hyperplasia with the destructive form, and concluded that the latter shows its malignant character comparatively early by invasion of the deeper structures, and by the gland tubules assuming an irregular form with increase of their epithelium. In every such case he would extirpate the uterus, relying entirely on the microscopic appearances.

This case points to the development of genuine carcinoma from typical adenoma; just as we find that recurrence after epithelioma of the portio vaginalis may show itself as true carcinoma. The argument that adenoma is therefore only a form of carcinoma applies with equal force to canceroid of the portio vaginalis.

Hofmeier maintains that adenoma malignum should be placed in a separate category from carcinoma. He calls attention to the facts of its development. It consists of tubules of cylindrical epithelium which may lie side by side, or form coils by twisting about one another with little or no connective tissue layer intervening. It penetrates and destroys the underlying parenchyma, and recurs after operation. He accepts the

statement made by another observer that the benign form does not invade the underlying uterine muscle; and that an important fact for diagnosis lies therein.

His statements are largely controversial in reference to Ruge and Veit, on the one hand, and to Abel and Landau on the other; and they depend chiefly upon his belief in microscopic diagnosis. The important clinical characters, and the local tissue changes which differentiate it from carcinoma, have been, however, described nowhere better than in a case reported from Würzburg by Ländlerer. This was clearly a case of adenoma malignum, although the author holds on throughout to his pre-conception as to cancer. The patient was a married woman, æt. 48 years; had borne five children, the last fifteen years before; for many years menstruation had been irregular, and for four years she had suffered from almost constant coloured discharge. No pain or subjective symptoms. On examination (April 1891) the uterus was found enlarged to the size of a man's fist; it presented some irregularities in form and resistance; the sound, passed over four inches, indicated soft masses and projections, and great congestion of mucosa. Portio vaginalis normal, multiparous. Abrasion of the mucosa with curette proved it vastly hypertrophied and softened: two teaspoonfuls of shreds of tissue were thus obtained. Microscopic examination led to diagnosis of endometritis glandularis hypertrophica.

Some futile treatment followed. Temporary cessation of hæmorrhage; relapse and readmission to hospital, December 1891. Patient suffering then from pain to some extent, loss of flesh and failure of strength, and extreme anæmia. Cervical part examined; still apparently normal: corporeal part large, hard, nodular, and congested, but perfectly movable. Repetition of curetting, microscopic examination of débris, and report with much circumstance. Result: Diagnosis of endometritis chronica glandularis hyperplastica, which condition was assumed to be produced by the presence of a myomatous interstitial tumour. Patient sent out with prescription for *hydrastis canadensis*.

Relapse once more; hæmorrhage, general pain, great loss of strength, anæmia. Author regretted that there was not a third curetting, *zu diagnostischen Zwecken*; but total extirpation was resolved on, and carried out on March 31, 1892—that is to say, after five years of hæmorrhage and one year of treatment. Patient recovered.

There is the usual prolix description of the macroscopic and microscopic appearances of the uterus. There was not a nodule of myoma anywhere, but there was great hypertrophy of apparently normal muscular tissue, with occasional small cysts disseminated through it, and there were polypous projections from the walls into the cavity of the uterus. Histologically the growth of gland cells was the most prominent feature; the deep layers of the mucosa showed that sometimes the epithelium assumed the form of papillæ springing from the gland cavity, and sometimes a striking palisade-like arrangement of long, narrow, and closely-set cylindrical epithelium. Apparently without connection with the



mucosa there were lying throughout the whole muscular layers of the uterus islands of a tissue exactly resembling the mucous lining in structure. . . . These islands were really connected by long, narrow, glandular tubules, which broke through the muscular layers, and then formed gland-like coils of tubes. In the small cysts the papillary projections have, according to the description, exactly the histological form and appearance of the "mucous polypi" seen at the os externum in either young or old women. The author proceeds to remark that the whole mode of extension is in contrast to that of the ordinary form of cancer of the body, which we designate alveolar. It is altogether a special form. In adenoma the cancerous glands in a loose open fashion break through the neighbouring tissues; the form of extension is almost dendritic. In alveolar cancer, on the other hand, the process is hardly ever diffuse; it leaves large portions of the uterus intact, and invades the contiguous tissues continuously from the mucosa outwards. The author finally calls attention, as others have done, to a feature which is more or less characteristic of the rapid growth of epithelial elements in adenoma; namely, the rapid development of the palisade-like arrangement of a long, narrow, closely-planted cylindrical epithelium. With the name adenoma benignum we must become accustomed to associate the idea of a tendency to take on malignant action, so that the epithet "benign" becomes merely a term of self-comfort and indecision.

Länderer refers to a separate cystic space in the uterine wall in advance of the general invasion as a metastasis. Cases have been reported in which genuine metastases occurred in the lungs and liver, in which recurrence, as carcinoma, took place in the cicatrix after total extirpation of the uterus, and in which the disease ran a much more rapid course than that which is almost characteristic.

In the inchoate state of our scientific observations of this disease, and the consequent unripe condition of our knowledge, it would be altogether premature to attempt any exposition of the subject under the usual heads of pathological anatomy, course and symptoms, diagnosis, and so forth. We see the chief points in the cases quoted: the usual advanced age of the patients, the insidious beginning and chronic course, the absence of fœtor and other characters of the discharge, the usual occurrence of hæmorrhage, and later the development of the symptoms and of the general condition of health are characteristic of cancer of the body of the uterus.

From incidents in the history of treatment we may also reflect, not without advantage, on the fatuity of comforting ourselves with a jargon of nomenclature, such as senile endometritis, fungous endometritis, diffuse benign adenoma, or even endometritis chronica glandularis hyperplastica, as applied to post-climacteric activity in the uterus.

All activity of the endometrium in post-climacteric women which is not completely accounted for by other ascertainable causes should be looked upon as malignant. When so-called soft mucous polypi occur they may be removed, their seat of origin may be destroyed by operation,

and then, owing to the chronicity of the disease, the case is lost sight of and the disease is believed to be cured. The disease may occasionally develop before the menopause, but all post-climacteric polypus or fungus of the endometrium of the body of the uterus is adenoma malignum.

**VI. Deciduoma Malignum.**—This disease of the uterus, which has received much attention in recent years from German and French gynæcologists and pathologists, is by reason of its rapidity of local growth, and tendency to metastases, the most malignant of all known maladies. To M. Säger (43), of Leipzig, is due the credit of first calling attention to this disease, to which he applied the name given above. He maintained that the tumour described by him was malignant, and consisted of decidual or placental elements so characteristic as to distinguish them from any other form of tumour found in the uterus. Later he spoke of it (44) as “an entirely new type of decidual tumour,” which had been recognised in the malignant metastases forming deciduoma or decidual sarcoma. In 1893 Säger (45) published his observations and opinions in a more complete form, including a review and criticism of the cases published meanwhile by other gynæcologists. He then gave up the name “deciduoma malignum,” and adopted “sarcoma deciduo-cellulare,” to indicate his view of the origin of the tumour. Subsequent controversy would appear to suggest that this change was rather precipitate.

Säger's own case is given in detail as follows:—

A woman married four months, in consequence of an accidental stumble in leaving a railway carriage, had an abortion in the eighth week of pregnancy. The ovum was not completely expelled, and she suffered from profuse hæmorrhage for three weeks. In the fourth week a foul-smelling discharge from the uterus began, with accompanying high temperature. When Säger was called in he found the patient very anæmic, with all the marks of retention of putrid parts of the ovum, and of septic absorption. The uterus was cleared of its contents after dilatation with laminaria tents; the temperature then fell, the bleeding and foul discharge also ceased, but the pulse never came down to 100. The general condition of the patient did not improve much, and five months elapsed before she could leave her bed. The convalescence was hindered by a diffuse mass of parametritic exudation in front and to the left of the uterus. This gradually disappeared without corresponding improvement in the patient's health. The uterus remained large, but the abdomen was flat, and there was no trace of peritonitis. There was never any purulent discharge from the pudenda. Soon the patient had to take to bed again, owing to a return of the fever and pain in the left hypogastrium. Then there appeared in the right iliac fossa a tumour about the size of a goose's egg; this tumour was soft, elastic, and tender on pressure. It was at first supposed to be an abscess, resulting from septic infection; and the enlargement of the uterus, which was now distinct, was attributed to the same cause. The patient was admitted to hospital, and an incision was made into the swelling. Instead, however, of the expected

pus, the spongy, fungous substance of a tumour appeared, and a handful of it was cleared out with the fingers and sharp spoon. At the bottom of the cavity the bone was found to be denuded of periosteum. Microscopic examination showed that the masses consisted of round cells with large nuclei, together with a small amount of spindle cells and blood-clot. Tubercle bacilli were not found. The patient was transferred to Professor Thiersch for further operation, but owing to her general condition, with new symptoms including cough and dyspnoea, nothing was done. The uterus increased to the size of a four months' pregnancy, while the patient became greatly emaciated, and she died seven months from the onset of the symptoms of abortion. The post-mortem examination, which was made by Professor Birch-Hirschfeld, gave some surprising results. The uterus was found to be the seat of several tumours, which were at first regarded as sarcoma teleangiectodes; and there were metastases in the lungs, diaphragm, ribs, and elsewhere. The uterine mucous membrane was smooth throughout; and this point is of the greatest interest in comparing Sanger's case with others subsequently published. Microscopic examination led Sanger to the conclusion that his case was one of malignant deciduoma not hitherto described; and from the opinion which he formed of its origin in the cells of the decidual connective tissue he classed it as a form of sarcoma.

Contributions to the phenomena and pathology of the new disease soon began to appear. The first case we find in which the disease was diagnosed during life, and an attempt made to cope with it, is that of Gottschalk (12).

The clinical facts show that hemorrhage began in February, in a case of abortion at two months, and the curette and tampon were repeatedly used during the whole summer as hemorrhage recurred; it was not until the 10th of August that the operation of extirpating the uterus was carried out as a last resource, "in spite of the deplorable condition of the patient." Gottschalk formed the opinion that the placental villousities had undergone a process of malignant degeneration. The cellules of the serotina had become infected with the sarcomatous virus; and a fetal tumour had been, as it were, injected into the maternal tissues, producing destruction of the uterine wall.

These are early representative incidents in a discussion which has been proceeding for several years, and to which many addresses and written papers have been contributed. Concerning much of the published material it is not too harsh to describe it as "arid," with a French reviewer, who had evidently suffered under it. The most recent contribution to the literature of the subject of deciduoma malignum appears to be the report of the proceedings of the Berlin Gynecological Society; and we may now ask whether any facts stand clearly and definitely out after the cloud of words has cleared away? Is there anything in it worth our knowing? The answer must be that there has been a definite addition to our knowledge, and as far as practical gynecology is concerned the matter is settled. The controversy among the pathologists appears to be only well begun.



*Pathological Anatomy.*—The characteristic feature which gives to deciduoma malignum a special place among the new growths is the presence of giant cells grouped in a particular way, and endowed with a power of reproduction which is almost or altogether unique. These cells are also found in the secondary growths, where they present exactly the same appearance and relationships. The tumour is produced by an abnormal proliferation of these giant cells of the decidua; but its bulk is also largely made up of a cellular tissue resembling sarcoma, and the cells of this class are found around the tumour invading and infiltrating the normal tissues of the organ affected. The giant cells have been carefully studied in their forms, grouping, and method of increase; and have been divided by Nové-Josserand and Lacroix into three categories, though the authors admit that there are numerous anomalous and intermediate forms. The presence in the best examples of deciduoma malignum of a considerable proportion of sarcoma-like substance has led to the inclusion of cases in this group of new growths which really belong to pure sarcoma; and from this confusion has arisen much of the controversy.

The characteristic structure of the tumour is the layer, seen on section, which lies between the necrosed tissue lining the uterine cavity and the genuine uterine substance more or less altered by the reaction produced by invasion. In addition to its special cell formation this portion of the tumour is extremely vascular; hence the profuse hæmorrhages which are so constantly referred to in the clinical history of each case. It is here that in some cases the villous arrangement can be observed, which in appearance suggests the chorionic villi; hence the division of the cases into two groups by Säger, and the name chorio-deciduoma malignum proposed by Gottschalk. The dendritic form in this malignant disease has been ascribed to a myxomatous degeneration of the villi, largely on the ground that the genuine deciduoma malignum is so often seen after hydatid mole pregnancy; but several competent pathologists, who have carefully examined the tumours formed after hydatid mole, have failed entirely to find any trace of the villous arrangement.

The ultimate facts concerning the point of departure of these growths have given rise to much controversy, and are by no means settled.

The opinions of Marchand (30) have been received with the greatest favour, and may be concisely stated.

*a.* All the cases are essentially of the same nature, although they present individual differences owing to varying conditions in the history of their development.

*b.* All the tumours are epithelial, the tissues combining in their formation being (*a*) the syncytium, that is, the uterine epithelial layer of the chorion; (*β*) the elements of the so-called cellular layer (layer of Langhans), that is, the ectodermal epithelium of the chorion.

*c.* The two orders of elements form a normal constituent of the serotina.

*d.* The derivatives from the syncytium take different forms: (*a*)



very large cells with large nuclei rich in chromatine; (*b*) protoplasmic masses with multiple nuclei; (*c*) trabecular and retiform multinuclear structures which are surrounded by blood-spaces, and which hold the same relation to these as the syncytium does to the intravillous spaces.

*e.* The elements of the cellular layer (of the ectoderm) most frequently occur as polyhedral clear cells containing glycogen. They multiply by indirect division of the nuclei. They vary in size, but are usually smaller than those of the syncytium.

*f.* Hydatid mole pregnancy favours the occurrence of malignant neoplasms, inasmuch as the epithelial elements penetrate the serotina more deeply than in normal pregnancy.

*g.* The decidua cells, properly so-called, do not participate in the formation of the malignant neoplasms, or only in a very small degree at the primary site of origin.

*h.* No participation of the connective tissue of the chorion in the formation of the malignant neoplasm has yet been demonstrated.

*i.* The formation of metastases from these tumours proceeds almost invariably by way of the blood-vessels.

Marchand having convinced himself that these malignant tumours, designated "deciduoma" and "sarcoma deciduo-cellulare," are really epithelial growths, proceeds to show cause why he should not adopt the obvious alternative in nomenclature, and call them carcinoma. He proposes, therefore, the term "serotinal tumour" as the most suitable.

Marchand's exposition of his views is sufficiently clear, and he appears to have brought some sort of order into the chaos of opinion existing among his colleagues. A timely contribution by him (29) to the structure and pathology of hydatid mole has also done much to clear up the confusion.

*Course and Symptoms.*—When we come to consider the symptoms and course in a typical case of the disease in question we are on surer ground. It is a disease *sui generis*. All experience proves that cancer of the body of the uterus is a disease of elderly women. The average age in twenty-six cases of deciduoma malignum was 33·7 years.

The first symptom is hæmorrhage coming on soon after parturition at full term, or after interruption of pregnancy, especially of hydatid mole pregnancy. Almost invariably the hæmorrhage has been attributed to retention of products of conception, a natural enough mistake until after the first curetting, not afterwards. Rarely as the disease occurs, it should always be suspected as the cause of hæmorrhage after the apparently complete expulsion of a hydatid mole. This cause of abortion was the immediately preceding fact in about half of all the cases reported. In one case, at least, it was only the facts ascertained by the microscopic examination of an extirpated uterus that led to the inquiries which completed the clinical history of hydatid mole pregnancy as immediately preceding the appearance of symptoms. Nové-Jossier and Lacroix have endeavoured to prove that the hæmorrhage presents certain constant characteristics. It is certainly more profuse than the hæmorrhage usually

occurring after abortion; the patients become excessively anæmic, and in some of the cases reported death was mainly due to the loss of blood.

The next symptom which appears comparatively early is profuse fœtid discharge. It is a dirty-water, sanguinolent fluid, which persists even after hæmorrhage has been temporarily suppressed by the use of the curette and other measures.

Deterioration of the general health now comes on rapidly; the patient becomes cachectic looking, can take no food, and soon loses flesh to a serious extent. She has all the appearance of suffering from malignant or advanced wasting organic disease.

Physical examination usually reveals the fact that the uterus is larger than normal and freely movable. In more advanced or neglected cases bimanual examination may bring out the fact that there are irregularities about the uterus or in the vagina due to secondary growths. Dilatation of the uterine canal will enable the medical attendant to ascertain the presence in the uterus of soft friable masses of vegetating tissue, like placental débris, mixed with more or less changed blood-clot. The tumour may be diffuse, but it is usually distinctly localised and attached to the wall of the body of the uterus. This fact distinguishes the case from one of retained shreds of placenta, membrane or blood-clot. Some have described the site of attachment after the removal of the tumour as giving the impression that the uterine wall was almost or altogether perforated. This appears to prove invasion of the wall of the uterus by the neoplasm.

When the case has become fairly advanced metastases invariably occur, and give rise to symptoms connected with the organ or organs so affected. In most cases lung symptoms arose, sometimes in such a marked form as to suggest pulmonary tubercle. In Gottschalk's case the lung symptoms were urgent before operation; but they afterwards so far improved as to suggest that they must have been sympathetic. The patient, however, died in a few months from widely diffused secondary growths.

In the course of the undecided treatment described in some cases local inflammation followed by septicæmic symptoms was observed, so that it must have been difficult or impossible to say whether the patient died from the original disease or from septicæmia.

An account of the clinical characters of such a disease as deciduoma malignum with its rare occurrence and recent history would not be complete without some illustrative cases.

Menge's case (31), from the University Hospital for Women of Leipzig, is fairly illustrative of the disease under consideration, and from the clinical point of view it is instructive. In December 1892, admission to the hospital of patient, æt. 35, pregnant six months, with uterine hæmorrhage; thirteen days after admission, expulsion of hydatid mole with assistance of manipulations of uterus; shreds of tumour left in uterus, causing hæmorrhage; rise of temperature to 103.5°; no treatment or interference. Eight days after abortion examination revealed "lochiometra"; insertion of index

finger into cervix to effect relief. On 8th January patient left hospital. In May an attack of hæmorrhage from the uterus occurred, for which the patient was treated at home by curetting. On 7th July admission again to hospital on account of pain and hæmorrhage. Dilation by tents and removal of nodules of tumour with finger and curette. Material thus obtained thrown away without examination. Rise of temperature to 104°. Patient sent home 16th July. Three weeks later patient again brought into hospital after almost fatally profuse hæmorrhage. Next day, after dilatation by tents, removal by sharp curette of large masses of placenta-like substance from body of uterus. Patient extremely anæmic. Temperature immediately after operation over 104°, after which rapid fall. Nodules removed subjected to careful examination. After delay of another week total extirpation resolved on and carried out. During operation the author was "very disagreeably surprised" to find secondary nodules in the vagina. Unsatisfactory recovery; rapid recurrence; death of patient six months after operation.

The special feature of this next case (56) was the length of time which elapsed between the mole abortion and the marked symptoms of malignant disease. The abortion occurred at about seven months, in May 1891; expulsion of hydatid mole, described by practitioner in attendance as amounting to from three to four quarts. Hæmorrhage in the summer of 1891, but not regular menstruation. In February 1892 foul-smelling discharge. In May 1892, when patient came under Löhlein's observation, there was a foul, blood-stained watery discharge; os uteri open, with irregular friable masses projecting. The tumour masses were removed, and the patient improved. After six weeks, return of symptoms with fever. Total extirpation of the uterus after removal of "polypus"; good recovery. Patient reported well five months later. Examination of uterus and tumour showed sarcoma structure with distributed nodules containing large "decidua-like cells." Löhlein considers the tumour exceptionally benign, but still within the category of sarcoma of the uterus, with a causal relationship to hydatid mole pregnancy.

In the following contribution by Klein to the history of malignant tumours of the decidua from the Royal University Hospital for Women, of Munich, the author gives an account of what he considers to be a case of decidual sarcoma after hydatid mole pregnancy. The interest of the case, except as a warning, lies largely in the post-mortem examination and the material obtained from it, which was subjected to careful investigation. The patient was a married woman *æt.* 27. She began to bleed in the last week of January 1893. The fundus of the uterus was then as high as the umbilicus. Hæmorrhage from the uterus continued to 12th March, although tampons were used almost daily, and a hydatid mole was then expelled. Hæmorrhage and pain frequently recurred. After nearly two months more the uterus was curetted. Some improvement for a short time, then relapse, with complications. It was not till November that the patient was sent in a dying state into the hospital by the practitioner who had attended from the beginning of the illness.

The disease was found to have spread to the vagina and parametrium, and there were small metastatic areas elsewhere.

One of the best reported and in other respects most satisfactory cases recorded is that of Nové-Josserand and Lacroix, of Lyons, already referred to.

The case, shortly stated, was as follows:— Married woman, *ætat* 24, became pregnant the third time in 1892. In March patient's abdomen was about the normal size at full term. Hæmorrhage for from six to eight weeks, then spontaneous expulsion of enormous hydatid mole. Patient well for a month, then recurrence of hæmorrhage every few days. Sent into hospital, under Fochier, 5th June. Examination after dilatation and removal of some friable débris; temporary cessation of hæmorrhage. Re-admission 10th July. Patient then losing blood from uterus profusely; had become exsanguine and so weak that she could not leave her bed; evening rise of temperature. Vaginal hysterectomy 12th July; recovery excellent. Patient reported well three months later.

Histological examination gave results similar to those already published, with additional, but not essentially different details. In the "clinical study" of the disease the authors direct particular attention to certain peculiarities about the hæmorrhages, which are intermittent, sudden, and profuse, endangering the life of the patient; and a metrorrhagic or serous discharge of small amount frequently occurs during the whole of the intervals. Tamponment only temporarily arrests the bleeding. Then the discharge becomes offensive, indicating infection of the uterine cavity. A rapid alteration in the condition of the patient takes place; loss of flesh, weakness, pallor, and anorexia supervene. Physical examination shows the uterus to be more or less enlarged, and exploration of the cavity at an early stage reveals the presence of a localised friable tumour. If this tumour be removed it is rapidly reproduced. There may be room for difference of opinion as to the details of the examination and the preparatory treatment recommended by Fochier; but the main point, prompt total extirpation, a measure which must commend itself to all gynæcologists, is strongly enforced.

*Diagnosis.*— Considering the marked character of the disease brought out in the cases recorded it will be obvious that there should now be little difficulty in any case which may occur. The main facts to keep in mind are:—

1. The history of recent parturition probably following interruption of pregnancy, especially of hydatid mole pregnancy. The existence of decidua in the uterus is a condition essential to the development of *deciduoma malignum*.

2. The symptoms of profuse hæmorrhage which have recurred again and again to such an extent as to have made the patient extremely anæmic.

3. The occurrence of a foul-smelling, thin, watery, or sanguineous discharge, which continues in spite of such curetting as may have put an



end to the hæmorrhage for the time being; anæmia, with loss of flesh and deterioration of the general health, with a rapidity and to an extent beyond that which might be expected from the symptoms and the duration of the disease.

4. Such symptoms demand closer investigation, and it becomes necessary to explore the uterus; it has become more or less enlarged, and when the uterine cavity has been dilated to admit the index finger, friable bleeding masses can be extracted and put under the microscope for differential diagnosis. The diagnosis, however, can be completely established by clinical facts alone. When the uterus has been explored, and the curette used once for all, if there be a recurrence of hæmorrhage and foul discharge, there is also recurrence of a malignant neoplasm.

It is easy to criticise the treatment of some of the early cases by men who were placed in an extremely difficult position in dealing with a rapidly fatal malady which they could not diagnose without the guidance of previous experience; and there can be no doubt that the repeated use of the curette in order to bring away débris of a recurring malignant growth could only hasten the occurrence of metastases. But the mistakes appear to have been honestly recorded, and the experience all points to this, that the patient's life depends upon prompt diagnosis and prompt definite treatment.

*Prognosis.* — The disease is rapidly fatal. The prognosis as to length of life depends upon the results of surgical treatment, and these results depend in their turn upon certain circumstances which have to be weighed: —

1. There is the immediate danger from the operation of hysterectomy.

2. The danger that secondary invasion has somewhere occurred, in which case all surgical measures will be in vain.

The development of metastases appears to depend upon — (*a*) the degree of malignancy in the different cases; (*b*) the lapse of time since the first symptoms appeared; (*c*) the amount of stimulation or wounding of the uterus resulting from manipulations intended for treatment.

There appears to be nothing in the previous individual health or family history of the patients to be considered. They are usually young and apparently healthy women with every expectation of life. The disease has some analogy to puerperal septicæmia, which beyond a certain stage is absolutely fatal unless a definite course of treatment be pursued; and fatal even in this case when far advanced.

*Treatment.* — All experience points definitely to one method of treatment and to no other; that is, total hysterectomy per vaginam, with the removal of as much of the ovaries, tubes, and broad ligaments as can be reached without producing undue danger of shock.

Some recorded cases warn us against indecision and delay. We have seen how to arrive at a diagnosis: as soon as the diagnosis is settled on clinical grounds the operation should be carried out. It is painful to read of patient and doctors waiting for the pathologist's report while the clinical facts point with moral certainty to the diagnosis, and while the

disease is rapidly developing about the uterus, and perhaps also sending its elements of reproduction to distant parts of the body.

Several cases are reported which warn us against the use of the tampon to arrest hæmorrhage in this disease; and against the repeated scraping of the cavity of the uterus even after the discharge has become septic and the neoplasm is recurring. Bacon reports a case in which the plug was used repeatedly over a period of many weeks to arrest hæmorrhage after a hydatid mole pregnancy; the curette was used six months after the symptoms appeared, and the patient died nine days after the operation. The post-mortem diagnosis suggests a great deal. It was as follows: "Deciduoma of the right broad ligament and of the lungs; endometritis and suppurative salpingitis; diffuse purulent peritonitis and empyema (bilateral);" with other more general disorders.

Such misfortunes and failures in treatment as are contained in the clinical records of this disease were inevitable in the case of the pioneers who had to grope on without the light of previous experience of so mysterious and terrible a malady as deciduoma malignum. They have, however, the satisfaction of knowing that they have placed the medical profession under a debt of gratitude by the faithfully detailed and honest accounts of their cases published for the guidance of others. Those of us to whom their records are open will be without their excuse if we fail to diagnose with precision, and to treat promptly and effectively any cases which may henceforth come into our hands.

W. J. SINCLAIR.

#### REFERENCES

1. ABEL. "Zur Technik der vaginalen Uterusextirpationen," *Arch. für Gynäk.* Bd. xlvii. H. 1. — 2. AUVARD. *Traité pratique de gynécologie*, p. 413. Paris, 1892. — 3. BACON. "A Case of deciduoma malignum," *Amer. Jour. of Obstet.* May 1895. — 4. BERNHARDT. "Kurze Mittheilung über eine neue Behandlung des inoperabilen Gebärmutterkrebses," *Centralblatt für Gynäk.* 1894. — 5. BUCHELER. "Ergebnisse der vaginalen Total extirpation mit Peritonealnaht," *Zeitschrift für Geb. und Gynäk.* Bd. xxx. H. 2, 1894. — 6. BUMM. *Verhandlungen der deutschen Gesellschaft für Gynäkologie*, 1892, p. 360. — 7. BÜRKLE. *On the Condition of the Patient after Vaginal Extirpation of the Cancerous Uterus.* Berlin, 1892. — 8. DÜHRSEN. *Centralblatt für Gynäk.* p. 309, 1874. — 9. FREUND. "Indicationen und Technik der abdominalen und vaginalen Total extirpation des Uterus," *Verhandlungen der deutschen Gesellschaft für Gynäkologie*, 1893. — 10. FRITSCH. *Krankheiten der Frauen*, 1894. — 11. FUERST. "Ueber suspectes und malignes Cervixadenom," *Zeitschrift für Geb. und Gynäk.* Bd. xiv. 1887. — 12. GOTTSCHALK. "Deciduoma malignum," *Berl. klin. Woch.* 1893, No. 4. — 13. GRIFFITH, W. S. A. "The Early Diagnosis of Cancer of the Uterus," *Brit. Med. Jour.* February 1, 1896, p. 265. — 14. GUSSEROW. *Die Neubildungen des Uterus.* — 15. HERMAN. "Early Diagnosis of Cancer of the Cervix Uteri," *Brit. Med. Jour.* 1894, p. 1911. — 16. HERNANDEZ. "Traitement du cancer de l'utérus gravide," *Ann. de Gynéc.* August 1894. — 17. HERZFELD. "Ueber die Sacrale Total extirpation des Uterus," *Verhandlungen der deutschen Gesellschaft für Gynäkologie*, 1893. — 18. HOFMEIER. "Zur Anatomie und Therapie des Carcinoma Corporis Uteri," *Zeitschrift für Geb. und Gynäk.* Bd. xxxii. 1895. — 19. JOSSEYRAND and LACROIX. "Sur le deciduome malin," *Annales de Gynéc.* 1894. — 20. KAHLDEN. "Das Sarkom des Uterus," *Ziegler's Beiträge zur path. Anat.* Bd. xiv. 1893. — 21. KLEIN. "Fall von Deciduo-sarcoma uteri giganteo-cellulare," *Arch. für Gynäk.* Bd. xlvii. H. 2, 1894. — 22. KRÜCKENBERG. "Die Resultate der operationen Behandlung des Carcinoms und

- Sarkoms der Gebärmutter," *Zeitschrift für Geb. und Gynäk.* Bd. xxiii. — 24. KUESTNER. *Das untere Uterinsegment und die Decidua Cervicalis.* Jena, 1882. — 25. LANDERER. "Ein Adenocarcinom des Corpus uteri," *Zeitschrift für Geb. und Gynäk.* Bd. xxv. 1892. — 26. LEOPOLD. *Verhandlungen der deutschen Gesellschaft für Gynäkologie*, 1891. — 27. LOEHLEIN. "Sarcoma deciduo-cellulare nach Vorausgegangenem Myoma chorii," *Centralblatt für Gynäk.* 1893. — 28. MANGIAGALLI. "Risultate prossimi e remoti della isterectomia vaginale per Carcinomia," *Annali di Ostetricia e Ginecologia*, November 1894. — 29. MARCHAND. "Ueber den Bau der Blasenmole," *Zeitschrift für Geb. und Gynäk.* Bd. xxxii. H. 3, 1895. — 30. *Ibid.* "Ueber die so-genannten 'decidualen' Geschwülste, etc." *Monat. f. Geburt. und Gynäk.* Bd. i. H. 5, 6, 1895. — 31. MENGE. "Ueber Deciduosarcoma uteri," *Zeitschrift für Geb. und Gynäk.* xxx. 2, 1894. — 32. MÜLLER. "Zur Lehre von Carcinoma Uteri," *Charité Annalen*, 1892. — 33. PFANNENSTIEL. "Das traubige Sarcom des Cervix Uteri," *Virchow's Arch.* cxvii. 1892. — 34. PICK. "Zur Histogenese und Klassification der Gebärmutter sarkome," *Arch. f. Gynäk.* Bd. xxi. p. 24; and WHITRIDGE WILLIAMS, "Contributions to the Histology and Histogenesis of Sarcoma of the Uterus," *Amer. Journ. of Obst.* vol. xxix. p. 721. — 35. PICK. "Zur Histogenese und Klassification der Gebärmutter," *Arch. f. Gynäk.* Bd. xlviii. 1894. — 36. PICOT. *Les grands processus morbides*, 1878. — 37. Quain's *Anatomy*, vol. iii. part iv. p. 266. — 38. RICHELOT. *Archives générales de médecine*, 1892. — 39. *Ibid.* "Derniers résultats de l'hysterectomie vaginale," *Annales de gynécologie*, Dec. 1895. — 40. RUGE and VEIT. *Zeitschrift für Geburt. und Gynäk.* Bd. iv. 1881. — 41. RUGE. "Das Mikroskop in der Gynakologie und die Diagnostik," *Zeitschrift für Geb. und Gynäk.* Bd. 20, 1890. — 42. *Ibid.* "Ueber Adenom des Uterus," *Verhandlungen der deutschen Gesellschaft*, 1888. — 43. SÄNGER. *Centralblatt für Gynäk.* 1889. — 44. *Ibid.* "Ueber Deciduome," *Verhandlung. der deutschen Gesellschaft*, 1892. — 45. *Ibid.* "Ueber Sarcoma uteri deciduo-cellulare und andere deciduale Geschwülste," *Archiv für Gynäk.* Bd. xlv. 1894. — 46. SCHMIDT. *Centralblatt für Gynäk.* No. 43, 1895. — 47. SCHULTZ. "Des injections intraparenchymateuses d'Alcool dans le traitement du cancer inoperable utérin," *Nouv. Arch. d'obstet. et de Gyn.* No. 10, 1894. — 48. SIMPSON. *Clinical Lectures on the Diseases of Women*, 1872. — 49. SPIEGELBERG. "Casuistische Mittheilungen zu den Sarcomen des Uterus," *Arch. f. Gynäk.* Bd. iv. 1872. — 50. TERRIER and HARTMAN. "Immediate and Remote Results of Vaginal Hysterectomy for Cancer," *Revue de Chirurgie*, 1892. — 51. THEILHABER. "Die Behandlung des Uteruscarcinoms in der Schwangerschaft und bei der Geburt," *Arch. für Gynäk.* Bd. xlvii. 1894. — 52. THORNTON, J. KNOWSLEY. *Address on the Early Diagnosis of Malignant Disease of the Uterus*, *Brit. Med. Assoc.* London, July 1895. — 53. VULLIET. "Ueber die palliative Behandlung des Uteruscarcinoms mit Alkoholinjektionen," *Centralblatt für Gynäk.* No. 34, 1895. — 54. WELLS, Sir SPENCER. *Morton Lectures*, 1888. — 55. WILLIAMS, Sir JOHN. *Cancer of the Uterus*. — 56. WINCKEL. *Diseases of Women*. — 57. WINTER. "Ueber die Recidive des Uterus Krebses," *Verhandlungen der deutschen Gesellschaft für Gynäkologie*, 1893. — 58. *Ibid.* "Ueber die Schroeder'sche Supravaginale Amputation bei Portiocarcinom," *Zeitschrift für Geburt. und Gynäk.* Bd. xxii. H. 1, 1891. — 59. *Zeitschrift für Geb. und Gynäk.* Bd. xxxiii.

W. J. S.

## PLASTIC GYNÆCOLOGICAL OPERATIONS

THE following lines will not contain a history of plastic gynæcic operations. It appeared to me better to describe the methods adopted in modern gynæcology, than to recapitulate all the procedures recommended by the many writers of the past.

Plastic operations in gynæcology may be conveniently considered under five headings:—

- A. Those for injuries and lacerations of the pelvic floor, due directly to the process of parturition.
- B. Those for displacements of the pelvic floor, including prolapsus uteri, cystocele, urethrocele, rectocele, and vaginal enterocele.
- C. Those for laceration of the cervix, the result of parturition.
- D. Those for certain cervical deformities and inflammations.
- E. Those for repair of fistulous openings between the bladder or intestine and other viscera.

A. OPERATIONS FOR INJURIES TO THE PELVIC FLOOR DIRECTLY DUE TO PARTURITION

The anatomy of the pelvic floor may with advantage be given in a few introductory words. This is composed from within outwards of (1) a pair of broad and thin muscles (the levatores ani), which are the chief means of support of the pelvic viscera; (2) an arrangement of fasciæ and muscles (more superficially situated), the components of which act as accessories.

1. The levatores ani, with the coccygei muscles, form the true pelvic diaphragm: each levator ani arises from the pubes, the white line of pelvic fascia, and the ischiatic spine, and sweeping downwards, forwards, and inwards, by its anterior fibres becomes attached, from before backwards, to the lower portion of the vagina, aiding in forming the lateral sulci; by its middle fibres to the rectum, blending with the internal sphincter; and by its posterior fibres to its fellow of the opposite side: the coccygei may be said to complete this pelvic diaphragm in its posterior portion. One of the chief functions of this musculature is to elevate the vagina and rectum, and to preserve the slit-like form with bilateral sulci which the former presents on transverse section. By the vaginal sulcus is meant the depression between the centre and side of the vagina which produces a kind of groove on each side.

2. The most external covering of the pelvic floor is a layer of superficial fascia, itself a continuation of the general body fascia; beneath this is a deeper layer, and, finally, there is the so-called triangular ligament which consists of an anterior and posterior lamina filling in the pubic arch. Between the deeper layer of the superficial fascia and the anterior lamina of the triangular ligament three important pairs of muscles are found: (*a*) The transversus perinei. (*β*) The bulbo-cavernosus. (*γ*) The erector clitoridis.

The perineum until recently was considered as a thick wedge-shaped body, partly muscular, partly tendinous, lying between the vagina in front and the rectum behind; and materially aiding in the support of the uterus: we now more accurately regard it as a movable centre of attachment for the transversus perinei, the sphincter and levator ani, and the pelvic fascia; as well as for the lower portion of the rectum and vagina. Thus the levator ani muscle, with the pelvic fascia, forms the



true pelvic floor on which the viscera rest, and through which the rectum and vagina find their exit.

The pelvic floor consists of two "segments" — an anterior or pubic and a posterior or sacral — separated by the vaginal slit or cleft; the pubic portion is slightly drawn up, or remains stationary during labour; while the sacral is pressed down and stretched during the passage of the fœtal head through the vulval orifice: hence it is that practically all the lacerations of the pelvic floor requiring repair are confined to the latter segment. These injuries are treated by certain operative procedures which may be immediate (that is, at the time of labour) or remote (that is, at some variable time after the accident, not earlier than eight weeks); this paper is devoted only to a consideration of the "remote" operations, as the "immediate" belong to the department of obstetrics.

**The lacerations of the pelvic floor fall into three classes: —**

i. *Partial Rupture of the Perineum.* — This consists of a median tear through the transversus perinei and bulbo-cavernosus muscles, and the superficial fascia up to, but not into the sphincter ani. It is a frequent result of the passage of the vertex through the pelvic outlet in first labours. As a rule it is productive of no bad symptoms, but occasionally gives rise to a feeling of descent of the pelvic viscera, to entrance of air into the vagina, and other sensations of a less definite nature. Neither prolapsus uteri nor gaping of the vaginal orifice occurs as a result of this accident.

On inspecting such parts in a woman, in the dorsal decubitus, who has been confined a sufficiently long time for complete cicatrisation to have taken place, it will be noticed that the vulval outlet is somewhat prolonged backwards, but is not patulous; upon separating the labia, a kidney-shaped surface covered by shining mucous membrane (cicatrical tissue), paler than usual and without rugæ, will be seen. The sites of the torn ends of the transversus perinei and bulbo-cavernosus cannot, of course, be detected. On being told to bear down there should be no more than an ordinary descent of the uterus and vaginal walls, and the sphincter will be found intact. The lateral vaginal sulci will be present and, on passing the finger into each, the supporting band of fibres of the levator ani may be distinctly made out. The sacral segment will be in apposition to the pubic, as is indicated by the close application of the anterior to the posterior vaginal walls.

ii. *Complete Rupture of the Perineum.* — This is a tear, usually median, through the perineum and internal sphincter ani. The patient suffering from this distressing condition has more or less complete incontinence of fœces and flatus, painful sitting-down, and not infrequently dyspareunia. The appearance of the parts after cicatrisation is somewhat as follows: the anus is represented by an opening, the shape of an isosceles triangle; the base of this triangle is formed by a concave corrugated surface — the posterior margin of the anus; the sides are the edges of the torn recto-vaginal septum. The sphincter ani being completely torn through, the ends have retracted, wrinkling the skin between

them; their site is indicated by a small, almost circular, depression upon each buttock (Fig. 154). The mucous membrane of the rectum is red,

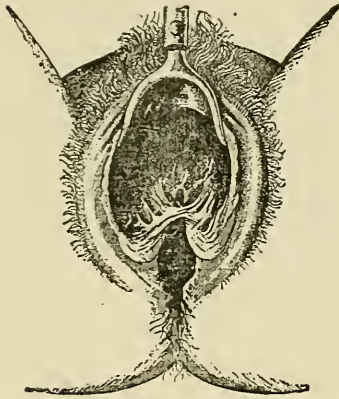

FIG. 154.—Complete rupture of the perineum and the lower portion of the recto-vaginal septum. The anterior vaginal wall retracted by speculum. A band of cicatricial tissue passes obliquely across the cleft. (After Pozzi.)

inflamed, and prolapsed or everted; it bleeds easily when touched, and secretes tenacious mucus. On introduction of the finger into the rectum there is a want of grip, and the edges of the torn recto-vaginal septum are more clearly defined. The anterior and posterior vaginal walls are in apposition, and the lateral sulci intact, as in the former case.

iii. *Lacerations of the Pelvic Floor Proper.*—These injuries are usually uni- or bilateral, and submucous, being produced by a tearing through of the fibres of the levator ani, especially of those attached to the vagina, rectum, and pelvic fascia. It is only after the patient begins to get about that the results of these lacerations are noticed.

If the attachments of the levator to the rectum and vaginal sulci be torn through, the sacral segment is dragged backwards towards the coccyx; the vulval orifice becomes elongated antero-posteriorly; the vaginal walls are everted, and the vulval outlet patulous—the latter condition being recognised in addition by the flatness of the crease between the buttocks, anterior to the anus; and the recto-vaginal wall, instead of being concave, becomes convex and protuberant, so as to produce a rectocele. The finger inserted into the vagina will fail to detect the attachment of the levatores ani to the lateral borders of the lower portions of the vagina; it is probable that the fibres of the levator ani attached to the left vaginal sulcus are those most usually torn through, owing to the frequency of the first position of the vertex.

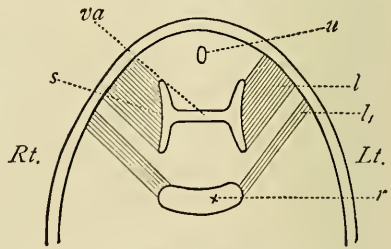

FIG. 155.—Relations of levator ani to the rectum and vaginal walls; normal condition. *u*, Urethra; *va*, vagina seen in section as a slit, with *s* its right lateral sulcus; *r*, rectum; *l*, levator ani muscle (vaginal fibres); *lt*, levator ani muscle (rectal fibres).

Typical instances of classes i., ii., and iii. are very frequent, but it must be borne in mind that it is very common to meet with cases in which complete perineal laceration is combined with lateral rents of the levator ani: in such cases the physical signs would present a compound of those depicted under class ii. and class iii.

It will be more convenient to consider together the plastic operations

necessary for the cases in class i. and class ii.; a full description of the technique to be adopted in class ii. will comprehend that of class i.

No plastic operation should be carried out without full antiseptic precautions; these are completely described in Dr. Amand Routh's paper on "Gynæcological Therapeutics," p. 249.

**Plastic Operation for Complete Laceration of the Perineum (class ii.).**—There is no procedure which, besides manual dexterity, requires greater care in the preparatory and after treatment than perineorrhaphy; and in order to describe it accurately, it is necessary to subdivide the subject into four headings: (a) Preparatory treatment; (b) Denudation; (c) Suturing; (d) After management. A fifth procedure, namely, stretching of the lacerated sphincter, is often inserted between the first and second of these, and is certainly useful in some cases.

(a) *Preparatory Treatment.*—The operation is performed under most favourable circumstances a week or ten days after the cessation of menstruation, and shortly after the patient's return from country or sea air. At least two months should have elapsed since the labour in which the injury was inflicted; the urine must be examined to ascertain the absence of albumin and sugar. If the woman be nursing her child it is better to wean it. For seven days the patient should be placed upon light diet—fish, eggs, and broth—and is better in bed, though this is not essential; some observers forbid the use of milk as apt to produce constipation. In order to get rid of all scybala from the large intestine, a pill composed as follows should be given every evening at bed-time for a week:—℞ Extr. aloes liq. gr. iss.-iiss., Pil. col. e. cal. gr. ij., Extr. cascar. sagrad. gr. iss., Extr. belladonnæ gr.  $\frac{1}{4}$ —the doses being so regulated as to produce two liquid motions daily. The night before the operation a full dose of ol. ricini should be administered, and a simple enema an hour before. For twenty-four hours immediately preceding the operation absolute rest in bed is necessary, and soup and barley water only as diet. During this week hot vaginal douches (temp. 110° to 120° F.) of 1 in 4000 corrosive sublimate solution should be administered thrice daily; these relieve congestion, soften the tissues, and prevent excessive venous oozing during the process of denudation. Should there be much leucorrhœa the douche may be followed by the introduction of a glycerine pledget, which protects the irritated surfaces from the discharge. Some operators are accustomed, a few days previously, to divide subcutaneously those scars which appear to distort the parts,

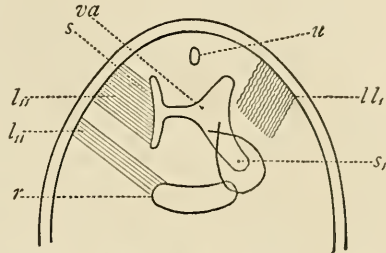

FIG. 156.—Relations of levator ani to the rectum and vaginal walls; injured condition. A deep tear through the vaginal and rectal fibres producing effacement of sulcus, and a patulous vagina. *u*, *va*, *s*, *r*, as in Fig. 155; *r'*, altered vaginal sulcus; *ll*, torn rectal and vaginal fibres; *ll'*, normal condition. (Diagrammatic form below.)



and are likely to interfere with the healing process; this procedure, however, is open to question.

Should the bowels have failed to act just before the anæsthetic is given, on its administration the rectum should be swabbed out, and any masses removed with the blunt spoon.

As the rectum communicates directly with the site of the operation, strict asepsis is impossible; at the same time contamination must be prevented as far as circumstances allow. The patient should lie in the dorsal position, with her knees supported and separated by a crutch; a mackintosh sheet, over which is a towel soaked in 1 in 4000 mercurial solution, should be laid under the buttocks; and a flat tray half filled with 1 in 20 carbolic acid solution, and containing the necessary instruments (recently boiled) is placed within easy reach of the operator, who should have gone through the usual purifying process on his own person.

Through a Sims' speculum the vaginal mucous membrane and the site of the rupture should be thoroughly and firmly rubbed over with cotton wool wetted with 1 in 1000 solution; the labia and parts about the perineum are shaved, and then purified, first with soap and water, afterwards with the perchloride solution.

The instruments necessary for the operation are (1) six pairs of Spencer Wells' artery forceps; (2) artery catch forceps; (3) long dissecting forceps, preferably with hooked ends; (4) a pair of sharp pointed angular scissors; (5) needles of various curves; (6) a needle holder, either Spencer Wells' or Hagedorn's, according to the needles in use.

Some operators stretch the sphincter, others condemn this practice; among the latter is Emmet. The reason for stretching is that when the torn ends of the sphincter are sutured, the irritation from collection of flatus and the bruising of the parts during the operation are productive of much reflex muscular contraction, which must prevent firm union or seriously interfere with it. If stretching be done before suturing the muscle remains paralysed for forty-eight hours at least, and good union takes place; moreover, after stretching, the ends of the contracted sphincter are more easily accessible. The manœuvre is carried out by grasping the tissues firmly on one side, over the depressed end of the sphincter, with the thumb and first finger of one hand, and forcibly stretching the contracted muscle with the other; this action is repeated on the other side.

(b) *Denudation* may be carried out either by paring, that is, removing a superficial layer of mucous membrane with the knife or scissors in order to leave a bare surface, or by the method termed "flap-splitting." The latter process is now generally adopted, and must be carefully described.

The patient being anæsthetised and lying in the dorsal position, the skin over the circular depressions (Fig. 157, *s s*) corresponding to the severed sphincter muscle (*k*) is seized with the hook dissecting forceps and slightly raised; with the scissors this portion of skin, say on the right side, should be excised, a procedure which bares the torn end of the muscle and opens



up the cellular tissue. The same manœuvre is carried out on the opposite side. The point of one blade of the scissors is now buried in the loose tissue at this bare spot on the right (operator's side) (Fig. 157, *s*), and carried along the edge of the vaginal opening between the superficial and deep tissue, until a point is reached above the level of the apex of the triangle formed by the rent of the recto-vaginal septum (Fig. 157, *a*): a few snips of the scissors will complete the incision; a similar manœuvre is carried out on the other side (Fig. 157, *b*). Starting again from the denuded spot (*s*), the point of the scissors is carried along the edge of the recto-vaginal septum in the direction of the arrow, separating it into an upper and lower flap. A similar incision beginning at *s*, meets this one at the apex of the triangle (*c*). If now the angles at *s* and *s*, be raised by catch forceps, and the scissors passed carefully into the cellular tissue, it will be seen how easily a flap is raised from the recto-vaginal septum (Fig. 158, *f*), leaving a raw bilobed surface. In Fig. 158 the flap has been raised, and it will be found that *s* and *w*, *s*, and *w*, are corresponding letters on the bare surface and flap respectively: the first finger of an assistant's hand in the rectum aids very much in bringing the different parts under the action of the scissors. This flap may be now cut away if there be a redundancy of tissue, as is sometimes the case; otherwise it is drawn up out of the way by a tenaculum and left to be dealt with later. The bleeding surface should be lightly swabbed over with small pieces of cotton wool dipped in 1 in 4000 solution and wrung nearly dry. Hæmorrhage soon ceases, as a rule, owing to the pinching action of the scissors; but if it continue, a hot douche of water at 110° F. should be played over the wound, and a sponge wrung out in water at the same temperature pressed upon it at intervals; if a distinct bleeding vessel can be made out, it must be seized with a Spencer Wells' forceps, which will remain attached until the sutures are passed.

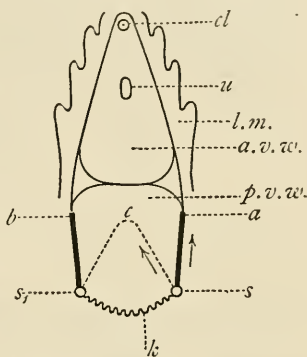

FIG. 157.—Perineorrhaphy; preliminary incisions. *cl*, Clitoris; *u*, urethral orifice; *l.m.*, labium minus; *a.v.w.*, anterior vaginal wall; *p.v.w.*, posterior vaginal wall; *k*, retracted sphincter. (Diagrammatic.)

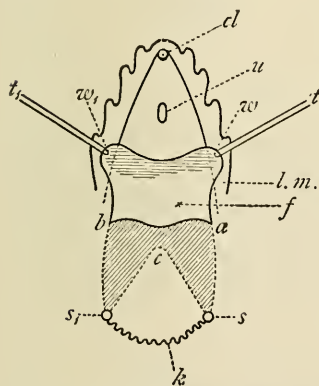

FIG. 158.—Perineorrhaphy; denudation. Flap (*f*) raised by tenacula (*t t*); *k*, *cl*, *u*, *l.m.*, as in Fig. 157.

(*c*) *Passage of the Sutures.*—The most suitable material is carbolic silk; but silver wire, chromic catgut, and silkworm gut are also extensively used by their respective advocates: a silk suture appears to me

to have the greatest advantages. Two sizes are required—a very fine one for repair of the torn recto-vaginal septum, and a slightly stouter material for the perineum proper.

*Closure of the recto-vaginal rent* may be performed in two ways:—by the “purse-string” suture, and by the interrupted “buried” suture.

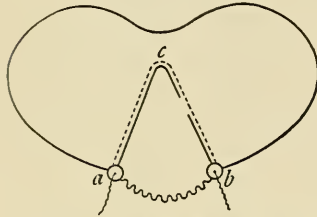

FIG. 159.—Purse-string suture; suture passed. *a, b*, Denuded ends of sphincter; *c*, angle of rent.

Fig. 159 illustrates the former method; the point of a fine half curved needle, in its holder, enters the point *b*; it is then passed up parallel with one side of the rent to the apex of the triangle *c*, brought down on the other side and out through the other cut end of the sphincter *a*. The two ends are tied tightly, so that the points *a, b*, and *c* are approximated, and the muscle repaired. Failure in operations on the

perineum is chiefly due to faults in passing the sutures; hence it is of the utmost importance that the severed ends of the sphincter should be carefully brought together. The latter procedure is more satisfactory, and consists in passing a series of sutures an eighth of an inch apart as shown in the diagram (Fig. 160). A needle threaded with very fine silk is passed through one edge (operator's left) of the rent from below; it is then carried over the laceration, and through the edge on the opposite side, from above downwards, so that when tied the knot will lie in the rectum itself. Five of these sutures are generally necessary, each being tied before the next is passed; the lowest is of the greatest importance, as by it the bulk of the sphincter is

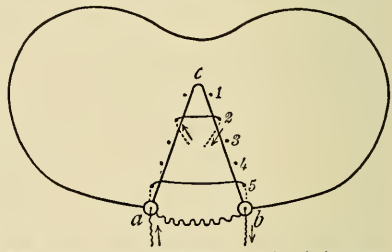

FIG. 160.—Perineorrhaphy; repair of the recto-vaginal septum. Sutures 2 and 5 are passed to show direction taken by the needle; the sites of ingress and egress of the others are indicated by dots with a corresponding figure.

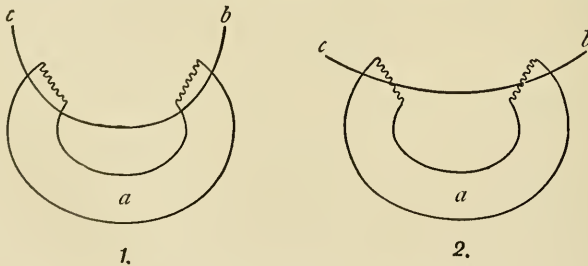

FIG. 161.—1. Section of torn sphincter (*a*), with suture (*b c*) properly passed. 2. Improperly passed.

repaired (Fig. 160, 5); if the little finger be passed into the newly made anus as the patient recovers consciousness, it will be grasped tightly.

It is now seen that a somewhat reniform raw surface is left, as in an incomplete rupture of the perineum already described, the repaired recto-vaginal septum forming a central vertical line in its lower part (Fig. 162): repair of this injury is extremely simple. The needle selected should be longer and stouter and the suture thicker than for the preceding step of the operation. The point of the needle is entered on the skin surface close to the raw edge, and pushed across the recto-vaginal septum beneath the denuded surface, emerging on the skin on the opposite side. Three other sutures are passed in the same way (I. II. III. IV.).

Nothing further should be done until bleeding ceases; the Spencer Wells' forceps can now be taken off, and if the surface remain fairly dry an antiseptic douche may be played over the wound, and the sutures tied or the wires twisted. Any blood flowing after the co-adaptation of the flaps or clots may break down into pus and prevent union. As the sutures are being secured the legs must be

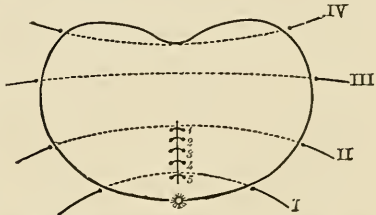

FIG. 162. — Perineorrhaphy; recto-vaginal septum repaired, the four superficial or perineal sutures passed, but not tied.

brought together and tied at the knees. The sutures should not be tied too tightly; practice only can enable the operator to gauge the proper amount of tension. Some local swelling always follows the operation. If at any part of the wound the edges are not quite in apposition, it is well to insert one or more superficial catgut stitches. The wound is now dusted over with iodoform powder; the urethral orifice is shown to the nurse in attendance to enable her to pass the catheter, and a wood-wool diaper is applied by means of a T bandage. The patient is then put to bed on her back, or side, with her knees tied together and supported over a bolster. No morphia suppository is necessary, as the patient rarely suffers pain, and no agent likely to produce constipation should be administered.

In those cases in which it is not thought desirable to cut away the dissected-up flap, three or more sutures are passed through its substance transversely, and it is, so to speak, longitudinally folded upon itself when these are tied.

(d) *The After Management.* — No opium or alcohol should be given. If vomiting come on after the anæsthetic, the nurse should support the perineum with the palm of her hand flat upon the diaper. The catheter is necessary every six hours, great care being taken to avoid dribbling of urine over the wound; the instrument when not in use should lie in 1 in 4000 solution. Some operators insist that the urine should be passed naturally from the beginning, lest the bladder be infected from the use of the catheter. No food is necessary for at least twelve hours; then only barley-water and milk, a teaspoonful at a time. Fluid diet only should be administered for twenty-four hours after the operation; gruel and bread and milk may be given on the second and third days. A

purgative of the same composition as that given before the operation must be administered on the evening of the third day, or even earlier; some operators give an aperient within twenty-four hours. Castor oil is of great value, but is often objected to by the patient; the compound liquorice powder in ʒj. doses is useful. A very efficacious plan is to give a teaspoonful of saturated solution of Epsom salts every half hour until the required result is attained. Flatus may be relieved by passing a catheter into the rectum, keeping it carefully pressed along the posterior rectal wall during introduction. If, before the action of the bowels takes place, the patient be aware of a scybalon in the rectum, a small amount of olive oil may with great advantage be injected into the bowel through a No. 8 male catheter.

After an action of the bowels the rectum should be washed out with a solution of boracic acid, to prevent contamination of the rectal sutures.

It was formerly customary to keep the bowels quiet until the sixth or seventh day; but it was found by experience that the scybala tore open the recently healed tissues. The object of the more modern treatment is to get early but liquid motions. No antiseptic vaginal douches are necessary; but twice daily the external genitals may be washed with a 1 in 4000 mercurial solution, and the gauze pad frequently changed to keep the wound dry. The sutures should be removed on the tenth day or before if they produce any irritation; a distinct rise in temperature, with a sensation of throbbing about the parts, followed by a purulent discharge, indicates that suppuration has taken place in some part of the wound.

Various modifications of the above method are in use, but of these two only need be described here; namely, that of Hegar, who modified Simon's operation (the "Simon-Hegar"), and that of A. Martin of Berlin.

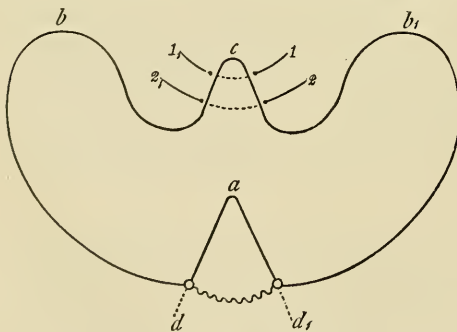

FIG. 163.—Perineorrhaphy (Simon-Hegar method of suture). *a*, Angle of recto-vaginal rent; *d d*, sites of torn ends of lacerated sphincter muscle; *c*, central tongue denuded and two sutures, 1 1., 2 2., passed; *b b*, extremities of denuded surfaces on labia majora.

Afterwards I shall describe Alexander Duke's mode of repair, which is on an entirely different plan.

*The "Simon-Hegar" Operation for complete Perineal Rupture.*—The principle upon which this method is founded assumes that the perineal body is torn on three surfaces, and that, to be successful in repairing the rent, sutures must be inserted on the vaginal, rectal, and external perineal surfaces.

The shape of the freshened surface may be compared in shape to a butterfly, the recto-vaginal septum being the body, and a tongue-shaped projection (Fig. 163, *c*) the head.



To mark out the area to be denuded a Sims' speculum is inserted to retract the anterior vaginal wall; and plugs of iodoform gauze are pushed into the rectum to prevent passage of fæces over the wound about to be made.

The hooked forceps should seize the mucous membrane at the point *c*, which point should be in the median line of the recto-vaginal septum, and two c.m. above the apex (*a*) of the tear through the sphincter. Two other points to be marked out are the extremities to which denudation is to take place on the inner surfaces of the labia majora (*b b*<sub>1</sub>). This butterfly-shaped area must now be bared of its mucous membrane by means of a knife or scissors; there is no flap-splitting.

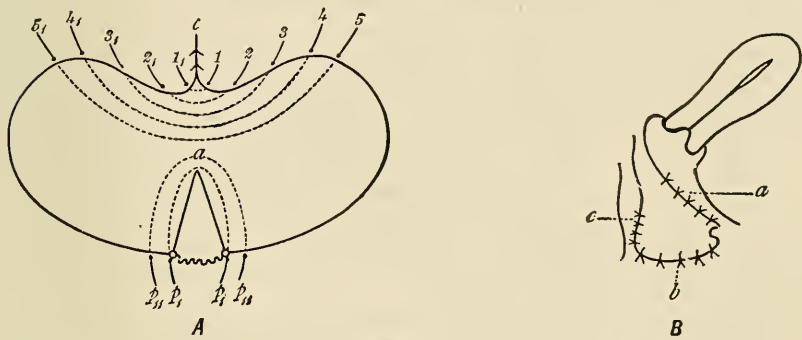

FIG. 164.

- A. Simon-Hegar method of suture, 2nd stage. The sutures 1 1, 2 2, in the tongue *c*, have been tied 1 1, 5 5, Vaginal sutures passed; *p*, *p*, *p*, *p*, perineal sutures passed.
- B. Simon-Hegar method completed (side view). *a*, Vaginal sutures tied; *b*, perineal; *c*, rectal.

Lateral venous sinuses may give rise to troublesome bleeding, but otherwise the hæmorrhage requires no treatment. Hegar warns operators against baring too extensive a surface, for when so much tissue is included between the stitches, suturing is rendered much more difficult and union less likely to take place.

The small central tongue should first be sutured and the stitches tied; two or three are sufficient (Fig. 164, A, *c*). This is supposed to give additional solidity to the recto-vaginal septum. Next the sphincter should be repaired, the needle being passed as is indicated in Fig. 164, A, *p*, *p*, *p*, *p*. The knots of these sutures will lie in the anterior rectal wall. The vaginal and perineal stitches are next inserted in the usual way.

The after treatment is as in the preceding operation, with the exception that Hegar recommends a purgative to be given on the fifth day, and that as soon as two free actions have taken place no more aperients be administered.

*A. Martin's Method.*—The denuded surface is the same as is recommended by Hegar and Simon, but the mode of suture is quite different. The flaps are brought together by the use of the continuous suture in superimposed layers (*vide* Figs. 169–171). The needle is entered at the

apex of the central triangle (Fig. 163, c) and continued downwards, so as to unite the edges of the recto-vaginal septum and thus repair the sphincter; an upward direction is now taken with the next superimposed layer, and finally the direction of the needle is again changed, and makes a series of superficial stitches from above downwards. Greater rapidity in the performance of the operation, and a closer adaptation of the raw surfaces, are the chief objects attained in this method.

*Alexander Duke's Method.* — This author published his mode of procedure in the *Dublin Medical Press* (9th May 1888); he considers it to be easy of performance and to make a good perineal floor.

The patient being prepared in the usual way, anaesthetised, and placed in the dorsal decubitus, the left index finger is introduced for almost its entire length into the rectum. "A long, straight, double-edged bistoury is now made to pierce the tissues *in front of the anus at right angles to the vulva*, and, guided by the finger in the rectum, is made to penetrate the septum for two and a half inches" in an upward direction. The incision may then be bilaterally widened to two inches as the knife is withdrawn (Fig. 165, *k k<sub>1</sub>*).

The patient being placed in the left lateral position, and the points *k k<sub>1</sub>* of the incision being pressed together, a lozenge-shaped opening will be made; sutures are passed in order to bring these raw surfaces together.

The sutures are introduced by means of a "strong sickle-shaped needle" (with the eye near the point) mounted on a handle. For suture the author prefers silver wire to any other material.

The needle is entered unthreaded at the edge of the incision on one side and, guided by a finger in the rectum, is made to travel under the raw surface to its full depth above, thus describing the arc of a circle; as the point of the needle appears directly opposite the wire is drawn through the eye: other sutures are passed in a similar manner.

If, after tying the stitches, a finger of each hand be passed into the rectum and vagina respectively, the septum will be found much thicker, and the external tissue pushed fully an inch forward from the anus.

Dr. Duke claims three great advantages for this method: (1) simplicity of performance and no fear of hæmorrhage; (2) no risk of sepsis, as the incision is not open for the admission of any discharge from either vagina or rectum during healing; (3) no loss of tissue.

**Plastic Operations for Lacerations of the Pelvic floor Proper (class iii.).**

— The treatment to be adopted in these cases differs very materially

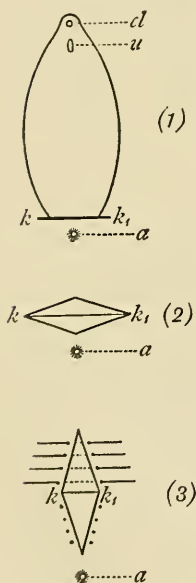

FIG. 165. — Alexander Duke's method. (1) Transverse incision (*k k<sub>1</sub>*) made; (2) conversion of incision into a lozenge-shaped cavity; (3) passage of sutures. *a*, anus; *cl*, clitoris; *u*, urethral orifice.

from the preceding: the objects to be attained are, first, to suture the torn ends of the levator to the lateral vaginal sulcus and perineum, and, secondly, to draw up or "lift" the pelvic floor.

The patient, both as regards diet and antiseptic precautions, is prepared as in the former case; and is placed in the dorsal decubitus. A Sims' speculum is inserted, and so placed as to elevate the anterior vaginal wall; the lateral sulci and the posterior wall are thus exposed.

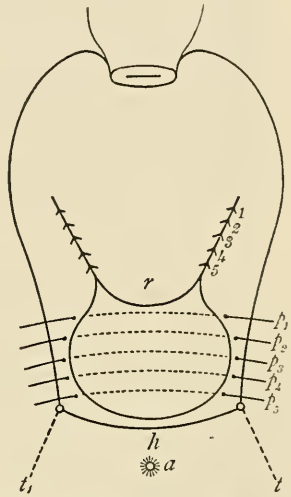
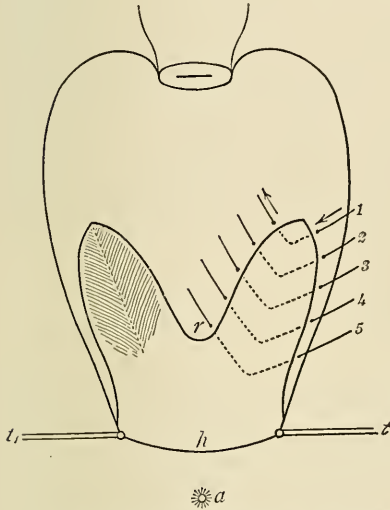

FIG. 166. — Surface view of posterior vaginal wall with right and left lateral sulci; the anterior wall supposed to be removed; on left side (patient's) sutures inserted, right side as the sulcus appears untouched. 1 to 5 sutures; their mode of passage being indicated by arrows; *h*, hymenal edge; *tt*, sites of attachment of tenacula; *r*, crest of rectocele.

FIG. 167. — Same view as Fig. 166 with both lateral vaginal sulci sutured, 1, 2, 3, 4, 5. Quadrilateral raw surface with sutures passed *p*<sub>1</sub>, *p*<sub>2</sub>, *p*<sub>3</sub>, *p*<sub>4</sub>, *p*<sub>5</sub> but not tied; *r*, crest of rectocele; *a*, anus; *h*, *tt*, as before.

With the left forefinger in the rectum the space to be denuded is mapped out by means of the sharp-pointed scissors, as shown in Fig. 166, the base line of the double triangle being formed by the site of the hymen (*h*): it is best marked out by inserting a tenaculum about three-quarters of an inch from the urethra on each side (*tt*), and using slight tension. The tip of the tongue between the two triangles should be situated on the most prominent point or crest of the rectocele (Figs. 166 and 167 *r*). The whole of the incisions must be contained in the vagina, and not extend to the vulva. The mucous membrane is now removed from this M-shaped space, particular care being taken to go deep enough into the sulci; bleeding is rarely severe enough to require the application of ligatures.

The insertion of the sutures is begun at the upper angle, usually on the left side (patient's) and after the manner shown in Fig. 166. The suture (1) is passed from the outside towards the median line; not straight across,

but first downwards and inwards to the centre of the denuded surface, and then upwards and outwards towards the mucous membrane through the tongue of the flap, as shown by the arrows in the figure: a series of four or five of these sutures are passed in a similar manner. On inspection of Fig. 156, which is an imaginary transverse section parallel to one of these sutures, it will be seen that the torn ends of the levator are sutured to the relaxed sulcus, and on tying the knot complete restoration of the parts to their original integrity results. Having completed the left triangle the right is treated in the same way, and we find that a roughly quadrilateral raw surface is still left below (Fig. 167); this is united by passing and tying four or more transverse buried sutures as in the operation for incomplete perineal rupture: a Y-shaped cicatrix should be the result.

The after treatment is exactly as detailed in class ii.; the sutures usually remain buried, cause no irritation, and do not require removal.

This is practically the operation devised by Emmet, and the steps of it are with very few exceptions the same as those laid down by him twenty-five years ago.

#### B. OPERATIONS FOR DISPLACEMENTS OF THE PELVIC FLOOR

Prolapsus uteri may be looked upon "as a downward and outward displacement of the entire displaceable portion of the pelvic floor, past the entire fixed portion," with eversion of the walls of the vagina (Berry Hart). Simple prolapsus may be complicated by more or less procidentia of the anterior and posterior vaginal walls, and by a varying amount of hypertrophy of the cervix. Prolapse of the anterior vaginal wall may occur alone or carry the posterior bladder wall down with it (cystocele). Both conditions are frequently cured by the same operation (anterior colporrhaphy), although for the latter a special one has been devised (Stoltz). In a similar manner prolapse of the posterior wall may be simple; or there may be in addition a displacement downwards of the anterior rectal wall (rectocele): both of these are treated by elytr- or colpoperineorrhaphy. The operative treatment of cystocele, enterocele, urethrocele, and prolapse of the urethral mucous membrane will be considered seriatim.

Hypertrophy usually affects the body of the uterus (metritis); apparent cervical hypertrophy is the result of the prolapsus: a differential diagnosis must therefore be made from congenital hypertrophy of the vaginal and the supravaginal cervix. As prolapsus uteri is usually attended by retroversion of the fundus this latter condition may require treatment.

For the purpose of selecting a suitable operation in each case it is better to divide these lesions into four divisions:—

(a) Prolapsus uteri and procidentia vaginae (cystocele and rectocele, etc.), associated with cervical hypertrophy. (b) Prolapsus uteri and procidentia vaginae, without cervical hypertrophy. (c) Prolapsus uteri, with



retroversion and procidentia vaginæ. (d) Simple procidentia vaginæ without uterine prolapse.

The various plastic operations to which resort can be had for the relief of the above conditions are:—

(i.) Those performed chiefly with the object of giving support to the prolapsed parts by repairing the perineum (perineorrhaphy); or, in addition to this, suturing together the inner edges of the pared labia majora (episio-perineorrhaphy). (ii.) Those performed with chief object of narrowing the vaginal walls (elytro- or colporrhaphy), or making a vaginal partition (Lefort's operation). (iii.) Combinations of i. and ii. (elytro- or colpoperineorrhaphy). (iv.) Those for prolapse of the posterior bladder wall with anterior vaginal wall (cystocele) of the urethra (urethrocele), of the urethral mucous membrane, and of the intestines (vaginal enterocele). (v.) Those tending to cure the metritis and cervical hypertrophy (curettagé, cervical amputation). (vi.) Those for the relief of the retroversion (vaginal fixation or hysteropexy).

(i.) Operations performed with the chief object of giving support to the prolapsed parts by perineorrhaphy or episio-perineorrhaphy.

(a) *Perineorrhaphy* or suture of the perineum has already been described (p. 747). Since the site of the operation scarcely includes the vaginal walls, it does not prevent their eversion; although it may contract the vulvar outlet. It is a useless and inadequate procedure in any but the mildest cases, and simply enables a pessary to be retained.

(b) *Episio-perineorrhaphy*. This operation consists in paring the inner and lower borders of the external labia in addition to the perineal surfaces, and suturing the opposing denuded areas together. The same objection obtains here as in perineorrhaphy and, except for the purpose of supporting a pessary, it is found to be equally useless.

(ii.) Operations performed with the object of narrowing the vaginal walls.

(a) *Elytrorrhaphy* or *Colporrhaphy*.—Sims' method. This is only performed on the anterior vaginal wall (anterior colporrhaphy); as originally devised a V-shaped surface was denuded, with the apex pointing downwards and commencing just above the urethra. On suturing these surfaces together a pocket was found to exist near the cervix into which the latter was liable to become incarcerated. Sims therefore added two short transverse denudations at the ends of this V (Fig. 168, *a a*<sub>1</sub>); on passing the sutures and tying them, a complete vertical fold of the anterior vaginal wall is produced, which in

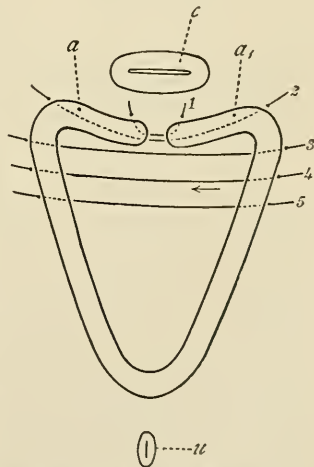

FIG. 168.—Elytrorrhaphy (Sims). The denudation is complete. *a a*<sub>1</sub>, Transverse bared surfaces; 1, 2, 3, 4, 5, sutures passed; *c*, cervix; *u*, urethral orifice.

suitable cases will be found to act as an adequate uterine support. Hegar makes his denuded surface in the form of a lozenge or rough ellipse, with the longer diameter in the axis of the vagina: he considers it useless to endeavour to make the flap of any particular shape, and advises the excision of all the redundant anterior vaginal wall. For practical purposes the denuded surface may be considered as of a more or less oval shape (Fig. 169); its upper border reaches as near the cervix as

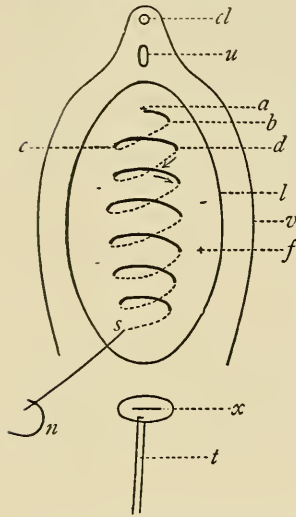

FIG. 169.—Anterior colporrhaphy; denudation and first layer of continuous suture completed. *a* to *s*, course of suture, the dotted portions being buried; *f*, denuded surface; *x*, cervix; *t*, tenaculum; *n*, needle; *v*, vulval outlet; *cl*, clitoris; *u*, urethral orifice.

The latter method is much the more expeditious, and will therefore be described.

A small half or fully curved needle threaded with a long piece of fine carbolic silk, a needle holder, and a pair of hooked forceps will be required.

The first suture is passed and tied (but not cut) near the urethral end of the incision (Fig. 169, *a*); the point of the needle is then entered at *b*, is passed beneath the denuded surface obliquely across to *c*, and then brought out, remaining exposed from *c* to *d*; it is then again passed obliquely beneath the surface, in the direction of the arrows: as each loop is passed it is tightened, and the silk kept taut by an assistant, while another loop is being passed. In the figures these loops are shown as still remaining loose in order better to demonstrate their mode of insertion. On drawing the suture tight a longitudinal line is produced between the two opposed folds (Fig. 170, *kk*), and the denuded area will be diminished

possible according to the amount of mucous membrane which can be drawn down to the vulva, while its lower edge is four-fifths of an inch behind the urethral orifice. The cervix is drawn down and steadied with a silver wire passed through its anterior lip. A Sims' speculum, lateral retractors, or the fingers of the assistant, may be used to expose the site of operation. Having marked out the area to be denuded with a scalpel, the upper edge of the flap should be seized with hooked forceps, and the sides steadied by tenacula; the mucous membrane can now be separated from the underlying tissues by means of a knife or scissors and gentle traction: the edge of the knife should always be turned towards the flap, to avoid cutting too deeply. Bleeding is as a rule very slight; if it persist, Spencer Wells' forceps should be applied and allowed to remain attached until the passage of the sutures.

Closure of the wound may be carried out by means of a deep and superficial layer of interrupted sutures; or by two or more layers of superimposed continuous sutures.

in size from side to side. The needle being brought out at *s* (Fig. 169), the silk is kept tense, ready for the suturing of the next layer. The point of the needle is passed superficially from *a* to *b* (Fig. 170) over the longitudinal line (*k*), that is, from the operator's left to his right. It is then passed back again in an opposite and upward direction beneath the raw surface, and emerges at *c*; it is superficial again from *c* to *d*, and buried again from *d* to *e*; the route taken by the needle being in the direction indicated by the arrows. The end of the suture is now brought out at *s*, and, if the denuded area be small, it may be tied and cut short. If, however, a third layer be necessary, the same procedure must be gone through, but from the urethral end downwards, the needle passing through points of junction of the denuded and mucous surfaces (Fig. 171). The needle has therefore during the operation passed from urethra to cervix, from cervix to urethra, and back again to cervix. It is important to remember that the deeper layer must be transfixed by the loops of the more superficial layer during the course of the suture from side to side.

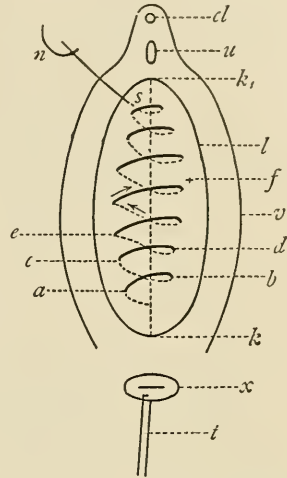

FIG. 170. — Anterior colporrhaphy; passage of second continuous superimposed suture. *k k*, The longitudinal puckering produced by the first layer of suture. The other letters as in Fig. 169.

The final cicatrix is obviously a straight line, running from the cervix to just above the urethra in the middle of the anterior vaginal wall.

The sutures do not require removal unless suppuration occurs along their track.

(β) *Lefort's Operation*.—This consists in the formation of an antero-posterior and longitudinal partition in the vagina. The originator of this operation bases his practice on the fact that prolapse of the vaginal walls almost always precedes that of the uterus; hence if the anterior and posterior vaginal walls can be kept in apposition the uterus must necessarily remain in its normal situation. The patient is anaesthetised and placed in the dorsal decubitus. The uterus is drawn out of the vulva to its fullest extent by means of a volsella. Four incisions are made on the anterior vaginal surface,

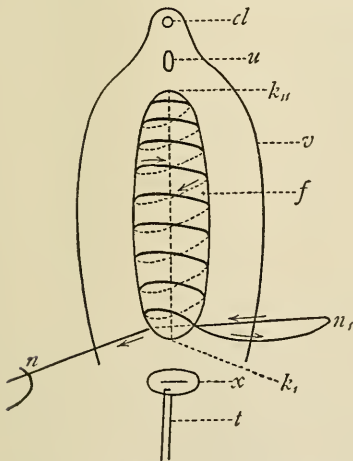

FIG. 171. — Anterior colporrhaphy; passage of third and final layer of superimposed suture. *k, k11*, Site of second layer; *n n1*, arrangement of silk preparatory to tying knot to complete operation.

enclosing a longitudinal space (Fig. 172, *f*) 6 centimetres long by 2 wide; the upper transverse line should be as near the vulva as possible. This area is denuded in the usual manner.

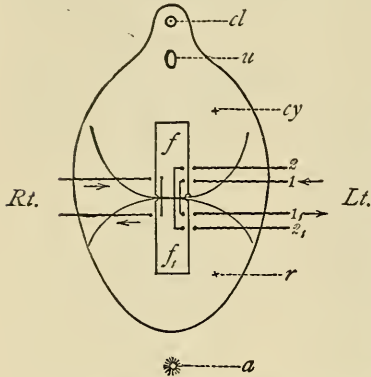

FIG. 172. — Lefort's operation; the anterior and posterior longitudinal areas *ff*, denuded. Two sutures, 1 1, 2 2, passed on left side, one on right; *cl*, clitoris; *u*, urethral orifice; *cy*, cystocele; *r*, rectocele; *a*, anus.

The cervix is now drawn upwards and forwards, and a similar area marked out and denuded on its posterior surface (Fig. 172, *f<sub>i</sub>*). Replacing the uterus sufficiently to bring the opposed surfaces into contact, as in Fig. 172, they are sutured together by a series of right and left lateral stitches (1 1, 2 2<sub>r</sub>); the first thread (1 1<sub>r</sub>) on the patient's left side being passed through the middle of the edge of the raw area nearest the cervix. The uterus is thus supported by a firm septum produced by the adhesion of portions of the anterior and posterior vaginal walls. The sutures are kept in for fourteen days or even longer.

The operation is said by Lefort to allow of coitus, but it is obviously one which would be selected for patients of more advanced age, and who have ceased to menstruate. Its performance has been attended by much success in France, but hitherto it has not gained favour elsewhere.

(iii.) Combination of i. and ii. (Elytro- or Colpoperineorrhaphy).

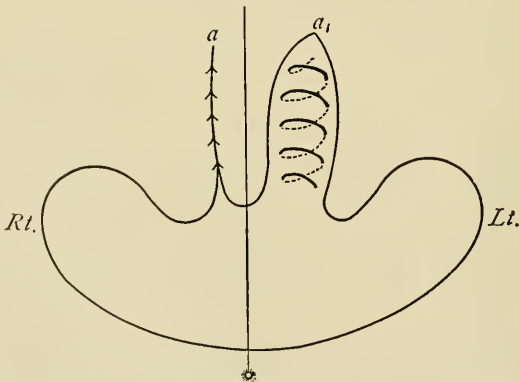

FIG. 173. — Colpoperineorrhaphy (A. Martin). 1st stage. Surface denuded, sutures passed (*a<sub>1</sub>*) and tied (*a*).

This operation consists in the performance of a posterior colporrhaphy concluded by an additional perineorrhaphy. The methods advocated by A. Martin and Hegar are those most in vogue; the former has been selected from among a large number for description. The advantage obtained by it is the preservation of the posterior column of the vagina,



which is very resistant and, according to Freund, should always be maintained intact.

*A. Martin's Operation.* — The usual antiseptic precautions must be taken in this as in all plastic operations; the patient being anæsthetised and in the dorsal position, the posterior wall of the vaginal *cul-de-sac* is seized by two pairs of hooked forceps, one on each side of the median line. Some traction is put upon them, with the result that the vaginal column appears strongly marked. On each side of this are made two longitudinal incisions; two corresponding flaps are removed, the amount varying according to the redundancy of the vaginal walls (Fig. 173, *a a*). The continuous buried suture is applied to each and two linear eicatrices result (Fig. 174). This concludes the first part of the operation or the posterior colporrhaphy; the perineorrhaphy or perineauxesis has now to be performed. The boundary lines are almost the same as in the operation for incomplete perineal rupture, the contained space presenting a semilunar appearance while the parts are at rest; but when traction is made upon its lower or anal extremity it assumes a lozenge shape (Fig. 174). The deep and superficial superimposed buried suture is now passed after the manner already described (p. 758), and the operation is finished; a Y-shaped scar results (Fig. 175). If antiseptic precautions have been carefully carried out, no suppuration takes place along the track of the sutures, and these may be left untouched.

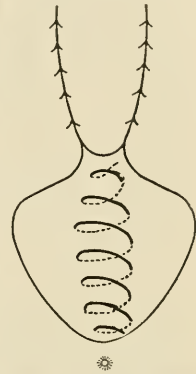

FIG. 174. — 2nd stage. First layer of superimposed suture passed.

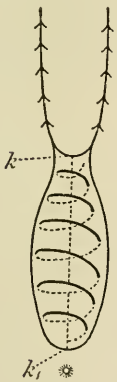

FIG. 175. — 3rd stage. Superficial layer of superimposed suture passed; operation complete.

(iv.) Operations for Cystocele, Urethrocele, Prolapse of the Urethral Mucous Membrane, and Enterocoele.

(a) *Cystocele.* — Whether the prolapsed anterior vaginal wall carry down the posterior bladder wall or not the operative treatment is the same; namely, by anterior colporrhaphy, already described (p. 757), or by a special method devised by Stoltz of Nancy.

The instruments necessary are a No. 8 male bladder sound, two tenacula, hooked forceps, sharp-pointed angular scissors, half-curved needles, and a holder (Spencer Wells' or Hagedorn's according to the kind of needle used). Fine carbolised silk is preferable for the suture.

The parts are best exposed by means of a Sims' speculum and a silver wire passed through the cervix (*x*), by means of which traction downwards and backwards may be exerted. Four points must be selected: two lateral (Fig. 176, 1 1<sub>1</sub>), fixing the external boundaries of the surface to be bared, one behind the urethral orifice (2), and another in front of the cervix (3): these four points should be capable of fairly close approximation. They are united by curved incisions, so that the space to

be denuded is almost circular in shape (*f*). The sound is now passed into the bladder, and the mucous membrane of the vagina kept on the stretch by pressure of its point. Denudation should be performed in the usual way with knife or scissors, the sound being used as a guide and a resistant body. As a rule no bleeding requires attention. The needle being threaded, its point is inserted on the right (operator's) side of the urethral orifice, and slightly below it. It passes beneath the mucous, and appears upon the raw surface; is again introduced on the mucous, and again made to come out on the denuded surface. This manœuvre is repeated all round the edge of the wound, and finally the thread brought out on the left (operator's) side of the urethra and below it (Fig. 176). Traction is then made upon the two ends of the suture at the same time that the sound (now removed from the bladder) is used to push in the projecting cystocele. The edges of the denuded surface are by this means drawn together and the prolapsed bladder wall restored to its normal situation. On tying the

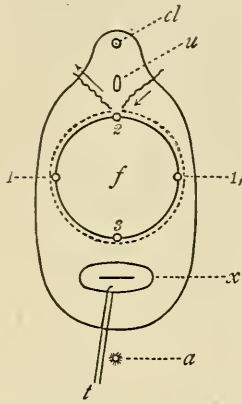

FIG. 176.—Stoltz's operation for cystocele. *f*, Denuded area; 1, 2, 3, points of attachment for tenacula before denudation; *cl*, clitoris; *u*, urethral orifice; *x*, cervix; *l*, wire or tenaculum; *a*, anus.

ends of the silk suture, the site of the operation will be marked by a pouch-like cicatrix. The urine should be drawn off every six or eight hours, and the suture withdrawn about the tenth day.

This method is of great value when combined with Martin's or Hegar's colpoperineorrhaphy for the treatment of cystocele and rectocele. It results in a very firm circular cicatrix, and requires very little manual dexterity for its performance.

The objection to Stoltz's method is that his operation tends to draw the cervix downwards; hence with a uterus prolapsed in a state of ante-version it would tend to aggravate the condition.

(β) In *urethrocele* there is a localised dilatation of the urethra in its middle third, the neck of the sac being more or less constricted. A certain amount of urine collects in this sac, and becomes alkaline or putrid (Fig. 177).

The sac should be opened by means of the scissors, or Pacquelin's cautery, and allowed to drain until the parts are in a more healthy condition: a very simple plastic operation can then be carried out, the edges of the wound being denuded and brought together by a deep and superficial set of interrupted sutures.

(γ) *Prolapse of the urethral mucous membrane* is recognised by the

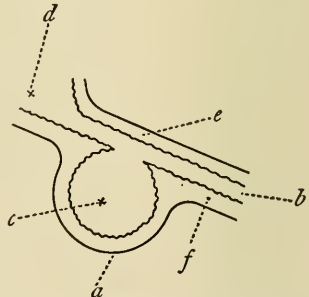

FIG. 177.—Urethrocele; lateral view in section. *a*, Vaginal surface of sac; *b*, urethra; *c*, cavity of urethrocele; *d*, bladder; *e*, anterior wall of urethra; *f*, posterior wall.

appearance at the meatus of a swelling of deep red colour, easily reducible.

Emmet's operation for the cure of this displacement is as follows: The patient is placed in the left lateral position, and a Sims' speculum inserted into the vagina; a button-hole longitudinal slit one and a half inches long is made into the urethra, and through this orifice from before backwards the redundant prolapsed portion of mucous membrane is drawn with a tenaculum. This is held by an assistant in the wound while a large-sized metal bladder sound is passed into the urethra, so as to smooth out the lining membrane and push it towards the neck of the bladder.

Sutures should now be passed through the flaps of the wound transversely, and in such a manner as to transfix the drawn-through lining membrane; the excess of this tissue is now cut away, and the opening brought together by means of interrupted carbolie silk sutures.

(δ) *Vaginal enterocele* may be either anterior or posterior; the anterior is so rare that it may be neglected. In posterior vaginal enterocele the intestines are forced down between the anterior rectal and posterior vaginal walls: as a consequence a large mass is found projecting like a rectocele. The cervix and uterus, however, remain in their normal situation. The patient being anæsthetised, and in the dorsal position, a volsella is attached to the posterior lip of the cervix, and some traction downwards and forwards is used; a space is then denuded on its posterior surface, and a corresponding one on the posterior vaginal wall; these raw surfaces are then sutured by means of carbolie silk in the usual manner, after reduction of the intestine.

(v.) Amputation of the cervix may be necessary for either supravaginal or infravaginal hypertrophy.

*Supravaginal hypertrophy* of the cervix is essentially a hypertrophy of the cervix above its insertion into the vagina; it occurs, as a rule, in nulliparous women. The uterus is increased in weight which causes prolapse; it should be noted that in this variety, as the uterus descends, prolapse of the upper part of the vagina takes place first, whereas in prolapsus uteri of the multiparous woman, rectocele and cystocele appear and precede the uterine prolapse.

*Infravaginal hypertrophy*—or more properly "elongation"—may occur:

1. As a complication of prolapsus uteri, when indeed it is apparent only: reduction of the displacement usually results in a disappearance of the hypertrophy.

2. As a congenital condition.

Amputation of an apparently elongated cervix in prolapsus uteri is rarely justifiable, but in the congenital form a plastic operation is certainly indicated (*vide* p. 769).

(vi.) Vaginal fixation (*Hysteropexy*) consists in fixing the retroverted fundus in a forward or anteverted position by suturing it to the anterior vaginal *cul-de-sac*.

This operation, which was originated by Shucking, has been im-

proved by Dührssen, and modified in some of its minor details by Mackenrodt.

*Dührssen's Operation.*—The patient being under the influence of an anæsthetic is placed in the dorsal position, with knees supported and kept apart by a Clover's crutch. The genitalia are thoroughly cleansed with 1 in 1000 mercurial solution, and, after inserting a Sims' speculum, the vaginal mucous membrane is carefully rubbed over with cotton wool dipped in the same mixture.

The anterior lip of the cervix is now seized with a volsella, and the uterus dragged down as low as possible; the uterine cavity is slightly dilated, and then scraped with a sharp flushing curette: possible contamination of the uterine sutures to be passed later is thus avoided. If the cervix be much hypertrophied it is amputated, as a large cervix tends to prevent the uterus remaining in a position of anteversion.

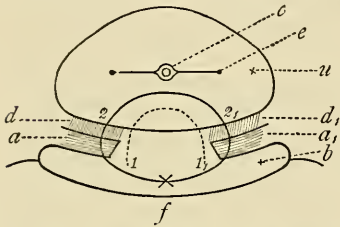

FIG. 178. — Vaginal fixation; transverse and somewhat oblique section above the level of the internal os uteri. 1 1, Temporary uterine suture; 2 2, suture including vaginal flaps, *a a<sub>1</sub>*, and uterine wall; this is tied at *x*; *b*, anterior vaginal *cul-de-sac*; *d d<sub>1</sub>*, cellular tissue in front of uterus; *c*, catheter in *e*, uterine cavity; *u*, uterine body; *f*, bladder.

A superficial transverse incision is made with a scalpel at the insertion of the anterior vaginal wall into the cervix; with scissors and the forefinger, the cellular tissue (Fig. 178, *d d<sub>1</sub>*) between the bladder and cervix is broken down until the peritoneum lining the utero-vesical pouch is reached. The peritoneal cavity is now opened and the edges sewn to those of the vaginal wound.

A No. 8 silver male catheter is now passed into the uterus, and by means of the usual *tour-de-maitre* it is anteverted; by pressure backwards of the handle the fundus, covered by the peritoneum, appears at the incision wound. With

a handled needle provided with a rectangular curve, a stout carbolised silk suture or silkworm gut stitch is passed through the anterior wall of the uterine fundus as high up as possible, the vaginal flaps not being, however, included; the ends of the suture are given to an assistant, who exerts traction downwards, allowing of the introduction of two or more further sutures into the anterior wall higher up than the first; the last should pierce the uterus at the level of the catheter point (Fig. 178, 1 1<sub>1</sub>). These are temporary, for traction only.

Three sutures should now be passed one above the other through the uterine wall, but including the edges of the vaginal flaps (2 2). The temporary ligatures may now be removed and the permanent ones tied; a superficial continuous suture may be inserted to obtain an accurate adaptation of the flaps.

The uterus will now be felt in a state of anteversion. After washing out the uterine cavity with an antiseptic solution the vagina must be packed with iodoform gauze.

The patient should be kept at absolute rest for fourteen days, and



have a ring pessary inserted before getting up. The value of this proceeding is still uncertain. The three dangers of the operation are— (i.) cutting one or both ureters; (ii.) wounding the bladder; (iii.) hæmorrhage from the vaginal flaps. Two after-effects must be taken into consideration; namely, a certain irritability of the bladder and a tendency to miscarriage, owing to the fixation of the anterior uterine wall to the vagina. It has been denied, however, by many that either of these sequels are met with. Dührssen has recently published statistics of 197 cases with one death (about 0·5 per cent).

*Mackenrodt's Modification.*— This operator does not consider it necessary to open the peritoneum in the anterior *cul-de-sac*, and is strongly opposed to fixing the uterus by carbolic silk suture or silkworm gut stitch; he transfixes the body of the uterus in preference to the fundus only, and also prefers a longitudinal vaginal incision.

The advantages claimed for this method are— 1. That the longitudinal incision does away with the risk of injury to ureters or bladder, and again that, where the vagina is roomy, and the walls lax, this incision can be converted into a rhomboidal one; thus an anterior colporrhaphy can be carried out, which strengthens the point of attachment of the uterus. 2. That by using absorbent catgut the uterus is maintained in place purely by adhesions, which in the event of pregnancy ensuing are capable of being stretched; repeated miscarriage after this operation is thereby avoided (Webb).

#### C. OPERATIONS FOR LACERATIONS OF THE CERVIX (NOT RECENT) THE RESULT OF PARTURITION (EMMET'S OPERATION OR TRACHELORRHAPHY AND ITS MODIFICATIONS)

If the cervix of a woman who has been confined at least two months be exposed by means of a Sims' speculum, one or more of the following conditions may be observed:—

- (a) The cervix may be normal, with the exception of two lateral notches more or less marked.
- (β) The anterior and posterior lip may be separated by one or two lateral rents extending to the vaginal roof.
- (γ) One or two lateral lacerations may be present as before, but in addition considerable extroversion of the cervical mucous membrane; the uterus will be probably subinvolved, and the patient suffering from menorrhagia, leucorrhœa, backache, and reflex disturbances. If a tenaculum be applied to the outer surface of each lip, and the two approximated, the extroversion disappears, and the rent becomes more apparent.
- (δ) The anterior lip may be torn through from front to back, the posterior being intact; or the reverse obtains, the posterior lip only being injured. Extroversion may or may not complicate either of these injuries.

(ε) The lacerations may be arranged in a stellate form and of varying depth.

Of these varieties none but those included under the headings (γ) and (δ) require operation, and then only when extroversion is present. Until recently it was considered that there was a direct relation between cervical lacerations and cancer; but so far no affirmative evidence has been adduced in support of this surmise. It is therefore obvious that the necessity for the performance of this operation does not frequently arise.

**Operation when there is a simple deep bilateral laceration with extroversion.**

*Preliminary Treatment.*—Vaginal injections of hot water (110° F.) should be used night and morning for a month or six weeks before the

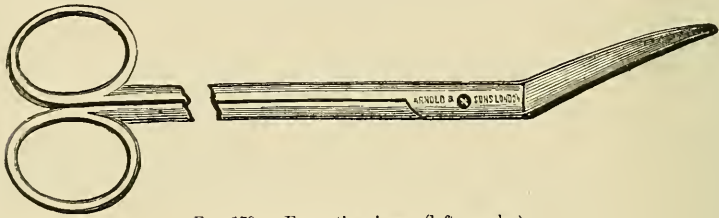

FIG. 179. — Emmet's scissors (left angular).

operation, and during this time the patient should be in the recumbent position. By their means local congestion is relieved, and the loss of blood at the operation from the denuded surfaces is much less. Should there be any cicatricial tissue at the base of the broad ligament in connection with either laceration, the corresponding fornix should be painted once every seven days with strong lin. iodi. The temperature should be normal night and morning, the urine free from albumin and sugar, and the general health of the patient good; it must be ascertained that there is no possibility of existing pregnancy.

*Actual Operation.*—The instruments required are: A Sims' speculum; volsellas and tenaculums; long-handled angular bladed knives (right and left); Emmet's scissors (right and left), angular (Fig. 179) and angular and curved (Fig. 180); needle holder; short stout needles, with sharp triangular points, straight or very slightly curved; two sizes of silver wire; carbolised silk suture (medium thickness).

If necessary the operation, which is painless, may be performed without general anæsthesia, local injections of a cocaine solution into the cervix being all that is requisite.

If a general anæsthetic be preferred, the patient, being brought under its influence and an antiseptic vaginal douche given, should be placed in the semiprone (Sims') position. The necessary manipulations are carried out much more easily in this attitude, although respiratory effort is somewhat interfered with. Some operators prefer the dorsal decubitus as giving more space, but this is open to doubt.

As subinvolution is almost invariably present, it is considered advisable to commence the procedure by *slight cervical dilatation and curettage*; it takes but a few more minutes, and is of great benefit to the patient.

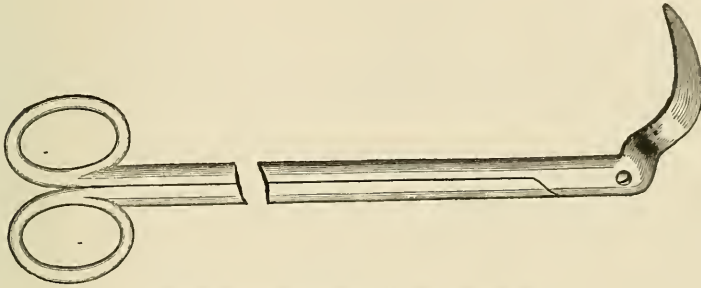

FIG. 180. — Emmet's scissors (angular and curved).

Having performed this with a flushing curette, introduce the Sims' speculum (Fig. 181, S) and expose the cervix. A piece of stout silver wire (*w*) should be passed deeply through the anterior lip (*a*<sub>1</sub>). By means of this steady traction can be made downwards, and the uterus kept firm while denudation and suturing are carried out.

If there be marked extroversion, with hypertrophy of the cervical glands, and the parts bleed easily on handling, erosion by means of the curette will make the subsequent steps easier of performance.

Having passed the uterine sound to mark the site of the internal os uteri (*o u i*), denudation is commenced. The lower portions of the anterior and posterior lips are first pared by means of the angular knives and scissors. An important site which frequently escapes is the deep angle of the laceration on each side (*l l*). The upper portions of the anterior and posterior lips may now be treated in a similar manner. A sufficiently broad strip (*a a*<sub>1</sub>) must be left unpared on both lips to avoid complete closure of the cervical canal when suturing is carried out. Any cicatrices at or about the angles of the laceration should now be excised; but, in doing so, large vessels may be opened and serious hæmorrhage result. Frequently the tissue is extremely hard, and great patience is necessary in order to denude

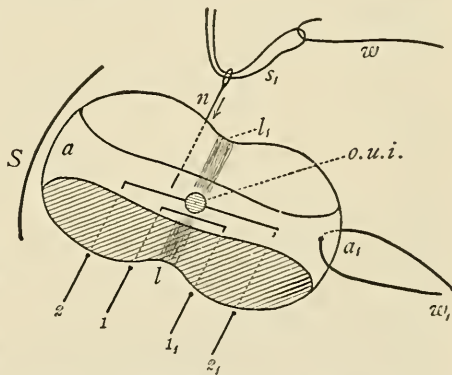

FIG. 181. — *a*, Posterior cervical lip; *a a*<sub>1</sub>, anterior cervical lip; *a a*<sub>1</sub>, undennuded strip; *w*, stout wire by which cervix is steadied; S, Sims' speculum (blade in section); *l l*, angles of deep laceration; *o u i*, os uteri internum; *n*, needle passing through upper bared surface; *s*, double thread, through loop of which the wire suture *w* is passed; 1 1, 2 2, sutures inserted but not tied.

the flaps thoroughly. An intermittent antiseptic douche should be used during denudation to wash away the blood and to preserve asepsis.

*The Introduction of the Sutures.*—Silvered copper wire of medium stoutness, and about 12 inches in length, should be used for each suture. The short, stout triangular pointed needle (*n*) is first doubly threaded with carbolised silk (*s*), so that a loop of 3 or 4 inches in length is produced. The needle and silk suture are passed, as in the upper portion of the figure, on the lower bared surface in the direction of the arrow, the loop remaining suspended from the point of entry. The wire suture (*w*) is hooked through it, and the needle and silk are rapidly pulled through beneath the raw surface, drawing the wire in their track. The needle is entered again at the edge of the undenuded strip, and passed directly outwards, the same manœuvre with regard to the silver wire being carried out. The other sutures are passed in a similar way; generally three or four are sufficient. The upper bared surface is treated in a like manner. The stout wire (*w*) is now removed, and the anterior and posterior flaps (*a*, *a*) are brought into apposition. The wires are twisted, but not too tightly; and the sound is passed to test the patency of the cervical canal. The ends of the wire sutures may be cut short or twisted together, covered with protective gauze and allowed to remain in the vagina. The latter method permits much easier access to the stitches when their removal is required.

*The after treatment* is not different from that to be followed after any other plastic operation. Vaginal gauze packing is not necessary. Should secondary hæmorrhage occur the cervix must be exposed through a Sims' speculum, and a suture passed through that half from which the bleeding is taking place. On tightly tying this the hæmorrhage will cease. The sutures may be removed on the tenth day, a small blunt hook being required to bring the loop of wire under the action of the scissors. In a successful case the cervix assumed a virgin appearance.

Dührssen describes a modification of Emmet's operation by "flap-splitting." He considers that a cervical laceration may be repaired without denudation by cutting into the tear at the line of junction of the cervical mucous membrane and that of the portia, the incision being  $\frac{1}{2}$  cm. in depth. On putting traction on the wound edges a raw surface is produced, the upper half of which is to be sutured to the lower. Another advantage claimed is that the cicatricial bands extending from the laceration into the parametric tissue can be safely divided.

Should the tear of the cervix have extended into the parametric tissue a cicatrix results, which draws over the uterus to the affected side. Severe pain may be caused by this condition, and Martin has proposed and carried out a plastic operation for its relief. The patient being anaesthetised, and in either the dorsal or left lateral position, the uterus is pulled over from the affected side, and a semilunar antero-posterior incision made over the base of the broad ligament, following the line of the cervix. The anterior and posterior extremities of the wound are



brought together by sutures, so that a transverse cicatrix results. Martin reports excellent results from this method.

#### D. OPERATIONS FOR CERTAIN CERVICAL DEFORMITIES AND INFLAMMATIONS

Cervical deformities requiring operation include stenosis of the os uteri externum and infravaginal hypertrophy; in chronic and intractable inflammation of the mucous membrane of the cervical canal resort to the knife is sometimes also necessary.

1. *For stenosis of the os uteri externum*, when associated with a conical cervix, Marckwald has introduced a flap operation which will be described in the next paragraph. In Germany and America it has met with considerable favour, but in England simple bilateral incision has been deemed sufficient.

2. *In hypertrophy of the vaginal portion* there is no thickening of the mucous and underlying tissues, hence the diameter of the cervix is not increased. On examination, the anterior and posterior fornices are in their normal situation, and the fundus uteri is found at its proper level in the pelvis; the sound may pass from 4 to 6 inches into the canal of the cervix. The os uteri externum is frequently very small. For the treatment of this condition nothing avails but removal of the hypertrophied portion; many methods have been recommended for this purpose, of which three have been selected for description.

(i.) Conoidal excision (Sims).

(ii.) Circular amputation (Hegar).

(iii.) Wedge-shaped excision of each lip (Marckwald).

A modification of ii. and iii. is advocated by A. R. Simpson.

*Sims* excised a cone-shaped portion of the cervix, and sutured the vaginal and cervical mucous membranes together.

*Hegar* has fully described his technique in his work. The patient being anæsthetised and in the dorsal position, the cervix is pulled down by a volsella and amputated with knife or scissors, the cut being directly transverse to the long axis of the hypertrophied organ; a certain amount of shrinkage of the stump takes place, producing an inversion of the vaginal mucous membrane (Fig. 182 A, a). A raw surface remains, over which the vaginal and cervical mucous membrane must be united by sutures. These are passed in the following manner: a short straight needle, double-threaded with a loop of carbolised silk, is passed from the vaginal mucous membrane (beneath the raw surface of the stump) to that of the cervix (c) in the direction of the arrows, and then brought back over the surface (Fig. 182 A, 1 1). Into this loop is hooked a piece of silver wire about 10 inches long, and by means of the silk pulled through the stump, which thus takes the place of the original suture: a series of these are passed and arranged in a radiating manner (1 1, 2 2, 3 3), and the wire loops are twisted so as to secure accurate adaptation and union by first intention (Fig. 182 B). The patient should remain in bed for fourteen days, and the sutures are best removed on the tenth day.

Marckwald's method, which is a modification of Simon's, has been in general use in Germany since the publication of his original paper on the

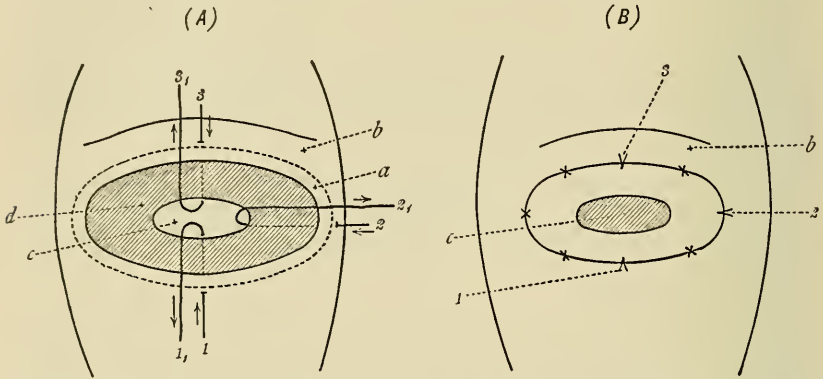

FIG. 182. — Amputation of cervix (Hegar). (A) Mode of passage of sutures; *a*, inverted vaginal mucous membrane; *b*, cervix; *c*, cervical canal in section; *d*, raw surface of stump. (B) Sutures tied; letters and figures as in A.

subject. The cervix is split into an anterior and posterior lip by means of scissors or the knife (Fig. 183 A, *a b*), and out of each is excised a wedge-shaped piece leaving a deep groove (Fig. 183, A, *c c c c*, B, *c c*), bounded by an anterior (B, *d d*) and posterior (B, *e e*) flap, front and

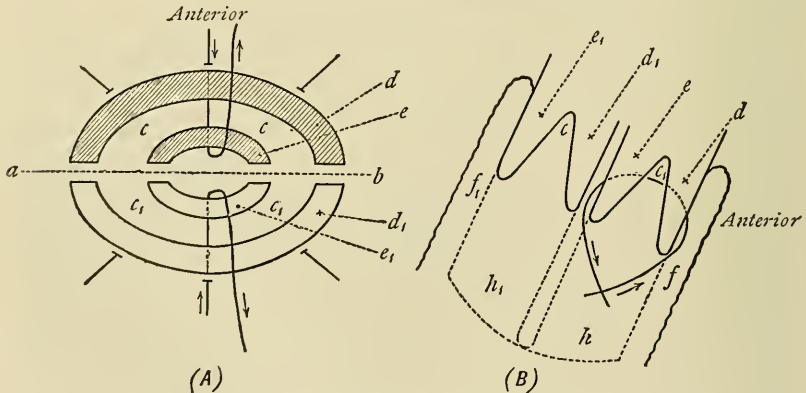

FIG. 183. — Amputation of the cervix (Marckwald's method). (A) Surface view. *a b*, Incision dividing cervix into anterior and posterior lips, in each of which is a wedge-shaped groove, *c c*, *c c*. The direction and mode of passage of two sutures is shown. (B) Side view. The dotted outline indicates the original dimensions of the cervix *h h*, *f f*, anterior and posterior fornix; *d e*, *d e*, anterior and posterior flaps of anterior and posterior lips of cervix respectively; *c c*, as in A.

back; the cervical surface of each is united to the corresponding vaginal surface by a series of sutures which are passed as shown in the diagram. The sound should be passed to ascertain if the cavities of cervix and body together do not exceed  $2\frac{1}{2}$  to 3 inches.

The advantages of this operation appear to be that it is almost entirely free from danger; no after bleeding can take place and, as a patent external os uteri is produced, it is of much value in stenosis; lastly, the technique is very simple and convalescence is rapid.

*Simpson* of Edinburgh introduces the sutures before amputating the hypertrophied cervix, the needle being passed through the whole thickness of the organ. After removing the mass each stitch is cut in two at the site of the cervical canal, and the stump treated as in *Hegar's* method. There are manifest advantages in this method: "It is easier to pass the needle through the dense tissue when the cervix is fixed with the volsella; the sutures serve as a means of traction when the portion grasped by the volsella has been cut away." Ligatures can be tied immediately the flaps have been made by amputation (*Hart and Barbour*).

If the sutures are of silver wire they should be removed in about ten days' time by means of a *Sims' speculum*, a rake (a blunt bent probe) to bring the embedded sutures into view, and a pair of scissors.

The removal of a hypertrophied cervix by an *ecraseur* or galvanocaustic wire is not to be recommended.

3. In certain cases of intractable cervical catarrh, it is a legitimate proceeding to excise the mucous membrane lining the cervix.

*Schroeder's* method consists in drawing down the cervix by means of two tenacula, one being attached to each lip; it is then divided bilaterally with knife or scissors, the incision being carried up to the vaginal fornix. A transverse incision is made at the base of each lip, and as high as can be reached, cutting right through the mucous membrane [*vide* Figs. 46, 47, p. 202, in *Dr. Barbour's* paper, "Inflammation of the Uterus"]. The point of the knife is next entered at *c*, and the blade passed up to join the deeper part of incision *a*. A large piece of mucous membrane is thus excised; the same manœuvre is carried out on the other side. The points *a* and *c* are brought together by sutures. The lower and middle portions of the cervical canal are now lined by vaginal mucous membrane.

*Martin* combines this with amputation of the cervix in his method of treating these cases.

#### E. OPERATIONS FOR REPAIR OF FISTULOUS OPENINGS BETWEEN THE BLADDER OR INTESTINE OR OTHER VISCERA

It will be convenient to subdivide fistulas into those in which the chief symptom is an involuntary escape of urine through the vagina (urinary) and those in which intestinal contents are similarly passed (fæcal).

**Urinary Fistulas.** — The septum between the genital and urinary channels may have its continuity destroyed in various situations; any artificial communication thus produced between two organs is called a fistula. The varieties of urinary fistulas are six in number, and are

named according to the organs between which an artificial opening occurs: 1. Urethro-vaginal; 2. Vesico-vaginal; 3. Vesico-utero-vaginal (juxta-cervical); 4. Vesico-uterine, cervical, corporeal; 5. Uretero-vaginal; 6. Uretero-uterine.

A rare condition in which the intestine (small or large) opens into the bladder, and fæces are passed with the urine, constitutes an entero-vesical fistula.

Of urinary fistulas, by far the most frequent is the vesico-vaginal; it is due either to direct injury to the vesico-vaginal wall during labour, or to a sloughing of the same subsequently, owing to prolonged impaction of the foetal head. An ulcerated opening may result from a vesical calculus. This variety of fistula frequently complicates the extension of malignant disease from the uterus to the bladder wall, and is artificially produced as a means of cure for chronic cystitis (Emmet's operation).

The urine dribbles away involuntarily, in a more or less continual stream; and the passage of the catheter gives a negative result. An exception, however, is found in those cases in which the opening exists above the orifices of the ureters; the patient then has a more or less considerable retentive power when in the erect position. Incontinence occurs immediately after labour, when the accident is due to the forceps or version; if it be not noticed until a few days subsequently it is due to sloughing of the parts pressed upon.

In urethro-vaginal fistula the urine is retained in the bladder, but passed in a stream through the lower portion of the vagina. In uretero-genital fistula urine is voided voluntarily at the usual times, and if the catheter be passed into the bladder a certain amount of secretion (but not so much as usual) is drawn off; the vagina will at the same time be found moistened with urine. This accident may be a sequel of total extirpation of the uterus. It will be most convenient to describe (I.) the operative treatment of vesico-vaginal fistula; and next (II.) the more complicated varieties.

**I. Vesico-vaginal Fistula.** — As this lesion is most frequently the result of prolonged pressure during parturition its situation will necessarily depend upon the point at which this pressure was most strongly exerted; hence it is usually found in the median line and behind the symphysis pubis. If, however, at the time of labour the bladder were distended, and therefore above the symphysis, the solution of continuity will be above the ureteral orifices. The size of these openings varies very much: the whole vesico-vaginal septum may be destroyed, producing an aperture as large as the palm of the hand; or the orifice may be so small as to escape notice, and admit a bristle only. The usual shape is oval or elliptical; but should cicatricial bands in the vaginal wall be present, the edges of the aperture may present every variety of irregularity. In the larger kinds the anterior bladder wall is protruded through the opening and may be covered with incrustations. The continual flow of alkaline and often decomposing urine over the vaginal walls and external genitals produces much redness, soreness, and swelling of the parts;



urinary concretions may be formed along the edges of the fistula or in the vagina. A urinous and characteristic odour emanates from the patient's person. There is usually amenorrhœa.

The plastic means adopted for the cure of this condition are by:—

(A.) The interrupted suture directly applied to the fistulous opening. (B.) Elytropy. (C.) Occlusion of the vagina below the fistula (kolpoplekisis).

(A.) *Suture*.—Three operators have each introduced a method of denuding and suturing a fistulous opening to which their names are respectively given; they are Sims, Simon, and Bozeman.

(i.) *Sims' Method*.—This is chiefly characterised by the careful preparatory treatment of the patient before operation, and by the use of silver wire for sutures; it is much in vogue in England and America. A description of this procedure may be given under four headings:—

(a) Preparation of the patient. (β) Denudation or vivifying of the edges of the fistula. (γ) Passing and securing the sutures. (δ) After treatment.

(a) *Preparation of the Patient*.—The importance of this measure cannot be over-estimated; without it failure will occur almost inevitably. Six months or more after the labour is the earliest time at which operative measures should be adopted. Constitutional treatment by means of tonics, a stay at the sea-side, with a course of shampooing and careful dieting, must be carried out for a month or six weeks. Hegar and Kaltensbach think six to eight weeks after the labour is the best time for operation. Much care and patience are necessary in the local management of such a case. The chief object to be attained is a healthy condition of the edges of the fistula, which are frequently inflamed, thickened, and covered by urinary deposits, usually phosphatic in nature. These deposits should first of all be removed by means of a soft sponge, and the raw surface brushed over with a weak solution of silver nitrate. Frequent hot vaginal douches and hip baths should be administered, and the parts carefully dried afterwards. The vaginal mucous membrane and vulva are then best smeared freely with vaseline to protect them from the action of the irritating urine. The napkins used by the patient must be thoroughly washed free of the urine with which they are saturated, and not simply dried.

So long as the phosphatic condition of the urine is present no local improvement will take place, hence it is desirable to produce acidity, and the following prescription is best adapted for that purpose: Acid. benzoici ʒj., Acid. borici ʒiss-ʒij., Aq. ʒvj.;  $\frac{1}{2}$ th part in water three times daily.

When a state of acidity is attained the dose may be reduced to such a quantity as to just keep the urine acid; too long a continuance of the larger dose is apt to produce gastric disturbance.

Vaginal cicatrices, besides the pain to which they give rise, often obstruct the view and treatment of the fistula, the introduction of sutures being rendered impossible thereby. These should be severed by scissors

in preference to the knife, as the hæmorrhage is less. A Sims' glass vaginal tube is then passed into the vagina to prevent reunion of the raw surfaces, and it may be worn a few hours daily; when it is removed the douche is to be given. Pressure applied in this manner frequently results in an absorption of the cicatricial tissue.

For the operation an anæsthetist, three assistants, and a nurse are requisite; one nurse will hold the Sims' speculum and elevate the right buttock, another will sponge and hand the instruments. The use of chloroform is advantageous in that it permits free access to the parts; the actual pain of the operation itself, however, is trifling.

The following instruments are necessary: A Sims' speculum; two flat spatulas; three long-handled knives, one with a long haft and a short, straight, narrow blade, the other two with angular blades (right and

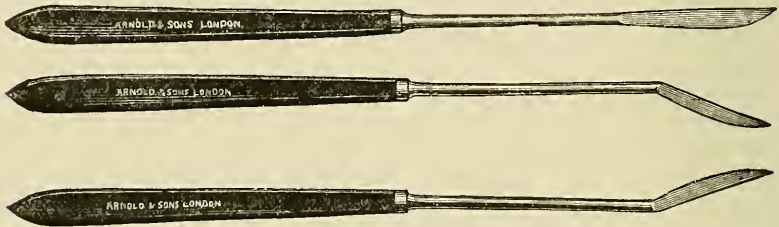

FIG. 184. — Vesico-vaginal fistula knives (Sims').

left) (Fig. 184); two long-handled, sharp-pointed, curved scissors (right and left); uterine hook (Emmet's) for making counter pressure (Fig.

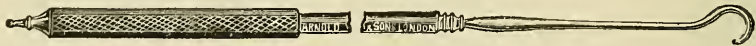

FIG. 185. — Uterine hook (Emmet's) for making counter pressure.

185); wire adjuster (Fig. 186); volsella and tenaculum; Spencer Wells' forceps; long toothed forceps; six sponge holders for very small



FIG. 186. — Wire adjuster.

sponges; needle holder and curved needles (from  $\frac{3}{4}$  to 1 in. long) with points not too sharp and cutting; silver wire and carbolic silk sutures; two sigmoid (S-shaped) catheters.

( $\beta$ ) *Denudation.* — The patient is placed in the left semiprone position. The fistula is thoroughly exposed, and a strong light thrown on to the site of operation by means of Sims' speculum; if necessary the cervix may be pulled downwards and backwards by means of a volsella attached to the anterior lip. The tenacula are applied at the opposite sides of the fistula to ascertain where the least traction will bring the edges together.

This being ascertained, the highest point of the fistulous edge is seized, either by long toothed forceps or a tenaculum, and placed slightly on the stretch. By means of a straight or angular bladed knife (Fig. 184) a strip of mucous membrane is then removed entire from the vaginal edge of the opening: the blade of the knife should cut in an oblique direction, and not touch the vesical mucous membrane, as an injury to it will inevitably lead to copious bleeding (Fig. 188, A, B). Some operators use scissors, and a combination of both instruments may be necessary in order to obtain a raw surface. Any hæmorrhage is checked by the intermittent hot douche and the pressure of small sponges on holders.

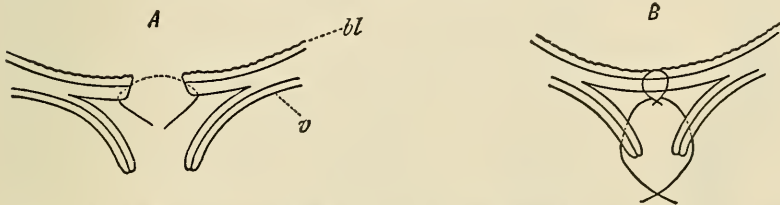

FIG. 187.—Mode of freshening the edges of a fistula by "flap-splitting." A. Flaps split and deep suture passed but not tied. *bl*, Bladder mucous membrane; *v*, vaginal mucous membrane. B. Deep suture tied and superficial one passed.

Another mode of freshening the edges is by the process of *dédoulement* or flap-splitting (Fig. 187, A, B); it is useful when the vagina is narrow, and there is not sufficient redundant tissue to make satisfactory flaps. The raw surface is produced by splitting up the edges of the

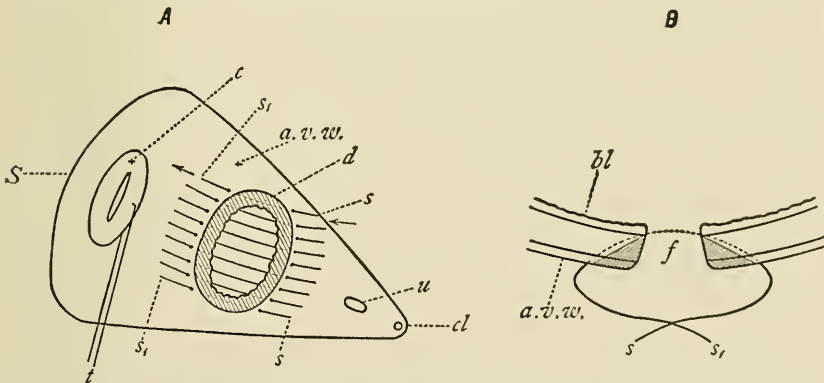

FIG. 188.—Mode of passing sutures in vesico-vaginal fistula. A. As seen in semiprone position. *S*, Sims' speculum, blade in section; *c*, cervix, secured by tenaculum *t*; *a.v.w.*, anterior vaginal wall; *d*, denuded surface; *s s s*, 1st and last of series of sutures; *u*, urethral orifice; *cl*, clitoris. B. As seen in section. *bl*, bladder mucous membrane; *a.v.w.*, anterior vaginal wall; *f*, fistulous opening; *s s*, suture passed but not tied. The shaded areas denote amount of tissue removed in denudation process.

fistulous openings, so that the mucous membrane of the bladder and vagina are separated all round; the flaps are brought together separately

by fine silk. No tissue is hereby lost, but the same accuracy of suturing is not possible as by the paring process.

(*γ*) *Passing and securing the sutures.*—The needle is first double threaded with carbolic silk; a tenaculum seizes the most inaccessible point of the denuded surface, and places the tissue on the stretch. By means of the holder the needle point is entered on the vaginal surface, about one-third of an inch from the raw edge, passed obliquely (Fig. 188) through the tissues, and brought out at the bladder orifice of the fistula; great care being taken to avoid the bladder mucous membrane. The needle is then entered again on the opposite side of the bladder opening of the fistula, and passed obliquely through the tissues; it emerges on the vaginal mucous membrane about one-third inch from the raw edge, and as nearly opposite the site on the other side as possible. Care must be observed not to make the point of entry of the needle more than half an inch from the raw edge, as the ureter may otherwise be included in the ligature. The wire suture about ten inches long is now hooked into the silk loop and pulled through.

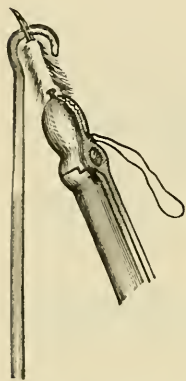

FIG. 189. — Mode of applying counter pressure to the point of the needle by means of a blunt hook (Emmet's).

In order to produce counter pressure on the tissues against the needle point, Emmet's blunt hook is used as in the diagram (Fig. 189). Care should be taken to include sufficient tissue in the sutures. A series of these are now passed in a similar manner about one-fifth of an inch apart. The two ends of the silver wire are now twisted together by means of forceps and a Sims' adjuster or shield (Fig. 186) — an instrument devised for accurate adaptation of the flap without producing torsion upon the tissues (Fig. 190). After all the sutures have been thus secured, they may be cut short and the sharp ends either covered with sealing wax or bent over. Having ascertained that the denuded edges are in accurate apposition, by inspection and by the injection of milk into the bladder, should the fistula be quadrilateral in outline the resulting cicatrix will be found to be Y-shaped; if oval, a transverse or longitudinal line will result. Sims' sigmoid catheter (a self-retaining instrument) with a long piece of india-rubber tubing attached may be introduced, and the patient put back to bed.

(*δ*) *After Treatment.* — The two chief complications to be encountered are hæmorrhage into the bladder and cystitis. The catheter should be changed daily, replaced by a second, and thoroughly cleansed before being used again. It is better for the tube to open into a deep dish filled with a 1 in 60 carbolic acid lotion. No other local treatment is necessary. The stitches may be removed about the tenth day.

Such is the operation as carried out by Sims and modified by Emmet.

When the fistula is close to the cervix, and treatment prevented by



its presence, it is better to incise the anterior cervical lip or to excise a wedged-shaped piece to allow of free inspection and access. The denudation should then be freely made around, and, in case of tension, liberating incisions are advisable: the sutures should then be passed as before.



FIG. 190. — Method of fixing and twisting the sutures (Sims').

In urethro-vaginal fistula the edges are denuded and sutures passed, as in the operation for prolapse of the urethral mucous membrane (p. 762).

(ii.) *Simon's method.*—This is carried out very extensively in Germany, and differs in many essentials from the preceding. It is fully detailed in that author's paper, published in 1862. Simon attaches less importance than did Sims to the preparatory treatment. The semiprone position is

replaced by an exaggerated lithotomy position, the buttocks being raised by a cushion, and the parts exposed by a handled speculum.

During denudation Simon endeavours to make the fistula a deep funnel-shaped aperture, with walls nearly perpendicular (*cf.* Sims' method), and thinks incision of the vesical mucous membrane of no moment. Should the fistula be small his mode of suture is somewhat similar to that already described; in the larger varieties, however, he introduces two sets of stitches — a deep or relaxing and a superficial set; the former enter and emerge at a considerable distance from the raw surface, and pass either close to the bladder lining or pierce it. The latter are passed alternately with the deeper. Care is taken to avoid inclusion of the mucous membrane of the bladder between the flaps. Silk is always used in preference to wire, and the sutures are placed very closely together.

As regards the after treatment the catheter is considered unnecessary, and the patient is allowed to pass the urine herself at whatever intervals she likes. Simon is of opinion that the urine has no ill-effect upon the healing of the wound, and that distension of the bladder (provided the stitches were inserted properly and tied firmly) does not matter. There are no restrictions as to diet. The sutures are removed as early as the fourth or fifth day.

(iii.) *Bozeman's, or the Button-suture method*, is again quite different from the two already described. The author is most careful in carrying out the preparatory treatment, concerning which he claims priority to Sims. He commences proceedings by "kolpoepetasis," or removing obstructions to the view of the fistula and to operation upon it. Any bands of adhesions are severed, and gradual dilatation is effected by means of an elastic bag or glass plug. This is continued until the fistulous opening can be well seen, and the edges are soft and lax.

The position in which he places the patient for operation is a modified genu-pectoral one; that is, she rests upon the knees with the legs apart, and the chest and head are supported in a horizontal direction by specially constructed cushions. The operator, therefore, sits facing the nates, with the anterior vaginal wall downwards. An anæsthetic may be given or not, but it is better avoided on account of the awkward position of the patient. Bozeman prefers to have little assistance; and, to attain this object, a trivalve speculum is inserted to expose the fistula, which is pared *in situ*; the uterus is not drawn down by a volsella.

After paring the edges the sutures are passed in the usual manner, and the ends instead of being tied are brought through a perforated plate which lies over the line of union, and are then fastened by means of perforated shot. An ordinary catheter is inserted into the bladder, and the after treatment is as in Sims' operation.

The special instruments used in this method are depicted in Bozeman's original paper, to which the reader is referred. The advantages claimed are, that the position of the patient allows better access to the fistula; that the perforated plate gives the margins of the flap more complete rest; and, finally, that it also protects the wound from urinary

and vaginal discharges. Although advocated by many surgeons in America it has not found much support in Europe, where Sims' and Simon's, or a modification of the two, are usually practised. Neugebauer of Warsaw performs the operation in the same position, and with a special apparatus for exposing the opening, but omits the use of the perforated plate.

(B.) *Elythroplasty* was first brought into notice by Jobert of Lamballe in 1834; it consists in raising a flap from various situations, such as the posterior wall of the vagina, the labium, or even the thigh, and suturing it accurately to the denuded edges of the fistula. This operation would only be necessary when there was much deficiency of tissue; and it is now almost entirely abandoned, in view of the results brought about by the preparatory treatment already described.

(C.) *Kolpokleisis*, or closure of the vagina below the fistulous opening, is resorted to when direct closure of the fistula is found impossible, and will be found described on page 780.

**II. Fistulas requiring Special Treatment.** — 1. In *vesico-utero-vaginal* or *juxta-cervical fistulas* the cervix is involved, and must be distinguished from the vesico-vaginal variety in which the cervix is intact.

They are subdivided into superficial and deep according to the partial or complete sloughing of the anterior cervical lip.

In the superficial form much may be obtained by simple denudation and suture; the tissues being extremely tough from cicatrisation the freshening must be extensive, as a healthy, broad, and pliable surface is more easily sutured than a cicatricial and inelastic one.

Deep juxta-cervical fistulas are very rarely amenable to treatment by suture, and it is generally necessary to bring the posterior lip of the cervix in apposition with the vaginal edge of the fistula, and stitch the two together. The os uteri, therefore, will open directly into the bladder. This operation has been termed *vesico-hystero-cleisis* by Pozzi.

2. *Vesico-uterine fistulas* may be cervical or corporeal. In the cervical form the anterior portion of the cervix should be dissected off the posterior or bladder wall to a distance above the orifice of the fistula. The anterior lip is split up to the cervical opening, and the denuded surface on the posterior bladder wall is then sutured in a similar manner to an anterior colporrhaphy, while the artificial cervical tear is treated by trachelorrhaphy.

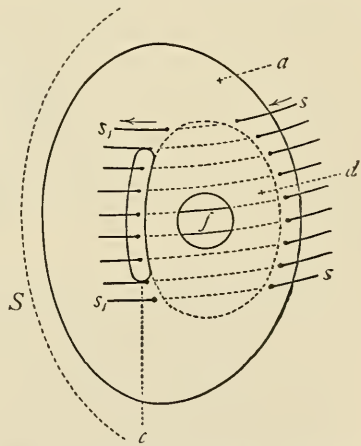

FIG. 191. — Juxta-cervical fistula (superficial variety). S, Sims' speculum in section; f, fistula; d, denuded area; c, cervical canal; a, anterior lip; s, s, s, s, series of sutures passed.

In the corporeal variety such an operation is obviously impossible; and the only treatment feasible is that of suturing the two lips of the cervix together — hystero-stomato-kleisis; the uterine secretions must, therefore, pass through the fistulous opening into the bladder.

3. *Uretero-vaginal Fistulas*. — These are frequently complicated by a vesico-vaginal fistula. Landau has invented and successfully performed the following operation for this condition: The patient is placed in the dorsal or left lateral position; if a vesico-vaginal fistula do not already exist, the surgeon makes one by the excision of an oval flap around the ureteral opening. A very fine gum elastic catheter is then passed into the renal or proximal end of the ureter, and into the urethra through the bladder. The genu-pectoral position is now assumed and the edges of the fistula denuded; a series of fine sutures are passed through the flaps at right angles to the ureter and tied. The catheter must remain in the ureter and urethra for at least eight days. Should union take place the ureteral opening into the bladder will necessarily be higher up than in the natural condition. In event of failure kolpokleisis, or some similar operation, is the only resource open to the patient.

4. *Uretero-uterine fistulas* obviously cannot be treated in this manner, and the only means of relief to be obtained is by excision of the corresponding kidney or artificial closure of the vagina or vulva by a plastic operation.

A recent and valuable paper on the treatment of vesical fistulas is that by Dr. Winternitz of Tübingen, and is well worthy of perusal.

The operations so far described for repair of urinary fistulas have been “direct” methods; allusion must now be made to the “indirect” modes of cure. These consist in closure of the genital canal at a point below the site of the fistula, so that the portion of the vagina above this becomes a part of the bladder; menstruation will then take place into this viscus.

Three varieties have been devised:—

1. Antero-posterior closure of the vulva, or *episiostenosis* (Vidal), the inner surfaces of the labia majora being denuded and brought together by sutures.
2. Complete vulval closure, with the formation of an artificial recto-vaginal fistula.
3. Obliteration of the vaginal canal transversely (*kolpokleisis*).

The two former have proved so unsatisfactory that they have been practically abandoned. In kolpokleisis, however, in some rare cases, we have a valuable operation. The indications for its performance are when the loss of tissue is too great to allow of direct suture of the fistulous edges; when there is much cicatricial tissue at the margins of the fistula, or when they are adherent to subjacent bone; lastly, when there is risk of wounding the peritoneum.

*Kolpokleisis*, or transverse obliteration of the vagina, may be performed in three places according to the situation of the fistula, at the urethral portion, that over the base of the bladder, and the fornix.



For the first of these Simon's position is the best, but for the two latter the decubitus advocated by Neugebauer is to be preferred.

A ring is first marked out by the point of a knife on the vaginal mucous membrane, below the fistulous opening; sufficient room being allowed to avoid the cicatricial tissue always present. Denudation is performed on the anterior surface with a sound in the bladder as a guide, while the finger in the rectum is necessary during the paring of the posterior surface.

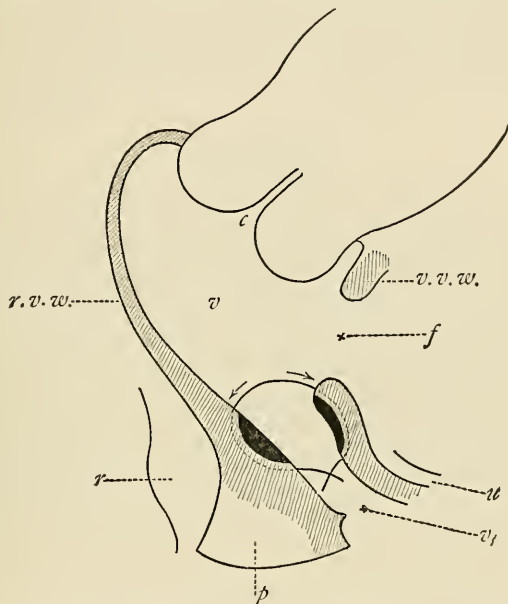

FIG. 192. — Kolpokleisis. Surfaces denuded, and one suture passed. *v.v.w.*, vesico-vaginal wall above fistulous opening *f*; *v.v.*, vagina; *v.v.w.*, recto-vaginal wall; *c*, os uteri externum; *u*, urethra; *p*, perineum; *r*, rectum.

The sutures of wire or carbolie silk are passed by means of two short half-curved stout needles, one at each end; both are passed from above downwards. The anterior needle (Fig. 192) will be entered on the vaginal surface, below the fistula, then pass through the substance of the vesico-vaginal septum, beneath the denuded area, and out again on the vaginal mucous membrane; the posterior needle will enter the recto-vaginal wall, immediately above the edge of the denuded area, pass beneath this, and have its exit on the vaginal aspect opposite to that of the anterior needle. Several similar sutures are passed, and they are then tied. Great care should be taken to avoid injuring the bladder or rectal mucous membrane by including either in the loop of the suture.

The objection to this method is that the vagina being closed, sexual connection is impossible; the patient should be warned of this result before consent to the operation is obtained.

Fæcal fistulas may be recto-vaginal, entero-vaginal, or recto-labial. *Recto-vaginal* fistula is an opening between vagina and rectum, and may be the result of parturition, when the lower portion of the sutured perineum has healed after suture, but the upper still remains open. Advancing malignant disease, rupture from abscess, and various kinds of ulcerative processes, may also lead to this condition. In cases in which a plastic operation is advisable, should the opening be low down, it is better to cut through the perineum and re-suture the two flaps after the manner already described in complete perineal rupture (p. 747): if the orifice be higher up denudation should be carried out over an area around it, and carbolised silk sutures passed as in vesico-vaginal fistulas.

JOHN PHILLIPS.

#### REFERENCES

1. BOZEMAN. *Remarks on Vesico-vaginal Fistula*, 1856. — 2. DUKE, ALEXANDER. *Dublin Medical Press*, May 9th, 1888. — 3. DÜHRSEN. *Archiv für Gynäkol.* 1894, Bd. xlvii. S. 281. — 4. EMMET. *The Principles and Practice of Gynæcology*, 1885, p. 817. — 5. FRITSCH. "Ueber plastische Operationen in der Scheide," *Centralblatt für Gynäkologie*, 1885, No. 49, S. 804. — 6. HEGAR. *Die operative Gynäkologie*, 1881, S. 462. — 7. LANDAU. "Ueber Entstehung, etc. der Harnleiterscheidenfisteln," *Archiv für Gynäkologie*, 1876, Bd. ix. S. 426. — 8. LEFORT, LÉON. "New Method for Curing Prolapse of the Uterus," *Bull. de Thérapeut.* Apr. 30, 1877. — 9. MARCKWALD. "Ueber die Kegelmantel-förmige Excision der Vaginal Portion," etc., *Archiv für Gynäkologie*, Bd. viii. S. 48. — 10. NEUGEBAUER. "Casuistik von 140 Vesico-Uterinfisteln," *Archiv für Gynäk.* Bd. xxxiii. S. 270, and Bd. xxxiv. S. 145. — 11. SHUCKING. *Centralblatt f. Gyn.* 1888, Bd. xii. S. 682. — 12. SIMON. *Ueber die Heilung der Blasenscheidenfisteln*, Rostock. — 13. VIDAL. "Obliteration of the Orifice of the Vagina as a Treatment for Vesico-vaginal Fistula," *Ann. de la chir. franc. et étrangère*, 1844, p. 208. — 14. WEBB, R. CURTIS. "On Mackenrodt's Operation," Thesis for M.B. degree, Cambridge, 1896. — 15. WINTERITZ. *Centralblatt für Gynäkologie*, 1895, No. 15, S. 377, with Bibliography.

J. P.

#### DISEASES OF THE FALLOPIAN TUBES

**Injuries of the Fallopian Tubes.**—The Fallopian tubes are tough, and no structures in the body are better protected by their position and relations. They accommodate themselves, as is well known, to the normal changes of the uterus in pregnancy. A wound of a Fallopian tube from a dagger or similar weapon would involve, in all probability, more serious injuries to neighbouring vessels and viscera than to the tube itself.

A healthy tube is sometimes cut through during an abdominal section. I have noticed that it does not bleed very freely; the blood mostly issues from small vessels in the investing mesosalpinx. The serious feature of such an injury is the exposure of a mucous canal which may contain septic matter. In most cases there is little or no danger even from

this source; still it is best to touch the exposed mucosa with tincture of iodine, especially if the surgeon intends to carry out some other part of the operation before removing the wounded tube. It is seldom of any use to sew up the injured tube, as it usually has to be removed with adjacent diseased structures.

The experience of countless ovariectomies teaches us that the healthy tube bears well the necessary injury inflicted by the ligature of the pedicle. The stump seldom sloughs, and when gangrene does occur the remains of the tube are not necessarily the seat or the origin of this grave incident. In cases of extensive disease of the appendages, on the other hand, the unhealthy tissues of the tube do not always tolerate the ligature. Sometimes the silk, when tightened, cuts through the tube. The real danger in such a case is not hæmorrhage, but exposure of the mucosa, as explained above; suppuration around the ligatured stump is not unknown.

**Atrophy and Hypertrophy of the Tube.**—After the menopause the tube shares in the atrophic process which involves the uterus. It likewise undergoes a certain amount of involution after pregnancy. The term atrophy cannot be applied to the arrested development of a malformation. In subjects who have died from chronic wasting diseases the tube is often found like a piece of thin twine, the fimbriæ being reduced to small, very pale, red shreds. In twisting of an ovarian pedicle atrophy of the tube may proceed to such an extent as to reduce it to a thin cord. In extreme cases the entire pedicle may part in the middle, and the uterine as well as the distal end of the divided tube is then always found in a state of extreme atrophy. The dragging of an omental adhesion may cause stretching and atrophy of the tube. As a rule adherent omentum is dragged down; but in exceptional cases the omentum may pull up the tube and stretch it considerably. I have observed two cases where this condition was well marked, the tube being atrophied.

Perimetritic bands pressing on the tube may bring on local atrophy, with obstruction of the lumen. Extreme atrophy of the tube may be occasioned by pressure between the pelvic wall and a large fibroid of the uterus.

Hypertrophy of the tube is a physiological condition in pregnancy. It must be remembered that in a healthy young woman the tube is a stout, deep red, tortuous, worm-like structure, with thick budding fimbriæ almost as big as the petals of a small carnation. Inexperienced operators, whose notions of a "normal" tube are based on the examination of dissecting-room subjects, or specimens shrunken from the action of spirit, may regard a healthy tube as diseased, or at least hypertrophied. True hypertrophy of the tube occurs when a myoma develops in the uterus near the cornu, and in all cases of large "fibroids" where the tumour does not press the tube against the pelvic wall. In ovarian cystic disease and in other pedunculated pelvic tumours the tube certainly grows longer, but it is not the essential tissues that undergo hypertrophy. I have always found that the mucosa appears more or less atrophied, the

fimbriæ being often much reduced in size. A yet more extreme condition is seen in the simple broad ligament cyst and other non-pedunculated tumours of the pelvis, where the tube undergoes great stretching and a certain amount of hypertrophy, in which the mucosa assuredly takes no part.

Hypertrophy of the muscular coat occurs in some forms of salpingitis.

**Inflammation of the Tube or Salpingitis.**—The earlier essential and purely local changes which occur when the tube is inflamed will be considered in the following paragraphs. These changes affect the coats of the tube and the ostium. The remarkable complications which follow when the disease is well established will be fully discussed in the section



FIG. 193. —Section of a healthy tube from a young subject. The corresponding ovary was removed, as it showed signs of incipient cystic disease. The opposite ovary formed a large tumour. The plicæ are delicate and well formed; very large vessels run in the muscular coat. (Beck,  $\frac{1}{4}$  inch.)

on pelvic inflammation. Here I need only note that amongst these changes are hydrosalpinx, pyosalpinx, and the rarer forms of hæmato-salpinx. The union of the cavity of a tube which has become cystic with the cavity of a cyst of any kind in the adjacent ovary produces the commoner form of tubo-ovarian cyst, which is to be distinguished from the teratological condition to which Mr. Bland Sutton has given the name of “ovarian hydrocele.” The development of the first or inflammatory variety was described by myself in 1887 (15*b*). Sutton makes the same distinction, or rather goes farther, and denies that an ovarian hydrocele is a “tubo-ovarian cyst” at all.

In the paragraphs on new growths of the tube, however, I shall return to the subject of salpingitis, bringing forward evidence that these new



growths specially affect tubes which have long been subject to inflammation. Indeed, it will be shown that papilloma, itself prone to undergo malignant degeneration, seems to originate amongst inflammatory products.

The observer, when studying sections of diseased Fallopian tube, must avoid the common error of taking normal for morbid appearances. Nor must he conclude that the presence of normal amongst morbid tissues necessarily implies that the disease is not advanced. The columnar epithelium lining the plicæ in health is, of course, perfect; but it is by no means the first structure to be distinctly affected by the inflammatory

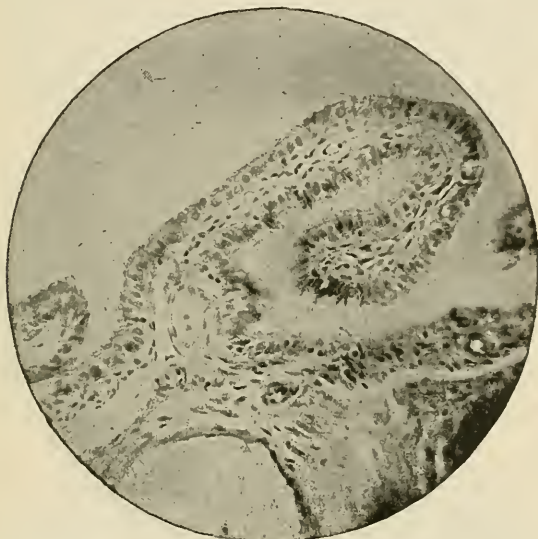

FIG. 194. — One of the plicæ in Fig. 193, as seen under a  $\frac{1}{8}$  inch objective. It is slender and well formed; its surface is invested with columnar ciliated epithelium.

process. In health large vessels with stout coats are to be found in the plicæ and at their roots. These vessels undergo changes, in relation to the menstrual cycle and pregnancy, not yet perfectly determined. In inflammation they tend, I find, to become obstructed rather than enlarged. The pathologist must not forget that in tubes removed by operation any marked change in the blood-vessels may be due to the ligature.

The naked-eye appearances in the earlier stages of salpingitis are not very distinct, even when the microscope can already reveal marked changes. A highly vascular appearance of the tube may be due to menstruation or the ligature, and a considerable amount of mucus may be seen in the healthy tubes. Exuberant fimbriæ are evidence of health and vigour, not of disease; the fimbriæ in inflammation tend to shorten and retract, as will be explained further on.

In early salpingitis the most prominent feature is small-celled infiltration of the plicæ, which causes them to become thick and club-shaped. (Compare Figs. 193 and 194 with Figs. 195 and 196.)<sup>1</sup>

The blood-vessels, at first perhaps dilated, soon appear narrower than in health. There is no rapid desquamation of the epithelium; indeed, this change need not take place at all. Mucoid degeneration of the cells is not rare; Weichselbaum admits its existence. It will be shown, however, that in advanced salpingitis the epithelium persists in certain places. Even when the inflamed tube becomes obstructed and dilated for months or years the epithelium may remain intact. In that case, as in less



FIG. 195. — Section, near the ostium, of an inflamed tube. The plicæ, normally very slender in this part of the tube, are thickened by small-celled infiltration ( $\frac{1}{2}$  inch objective).

chronic disease, the cells become low and cubical, and lose their cilia (Fig. 197). The nuclei become large and spheroidal, nearly filling the cell. Schramm describes this appearance as occurring early in tubercular disease of the tube.

A characteristic change, peculiar for evident reasons to salpingitis, soon follows. This change is the adhesion of the edges of adjacent fimbriæ. The small-celled infiltration presses the swollen edges together, and the epithelial surfaces thus in contact become destroyed, so that the cells disappear by a purely secondary change quite unlike what is understood by catarrhal desquamation. The plicæ, however, remain apart near their roots. Here the epithelium remains intact, another proof how

<sup>1</sup> The photo-micrographs illustrating salpingitis were kindly taken by Mr. Edmund Roughton and Mr. H. Cosens from sections of diseased tubes which I have removed by operation. I have been careful to select cases where the clinical history was very clear.

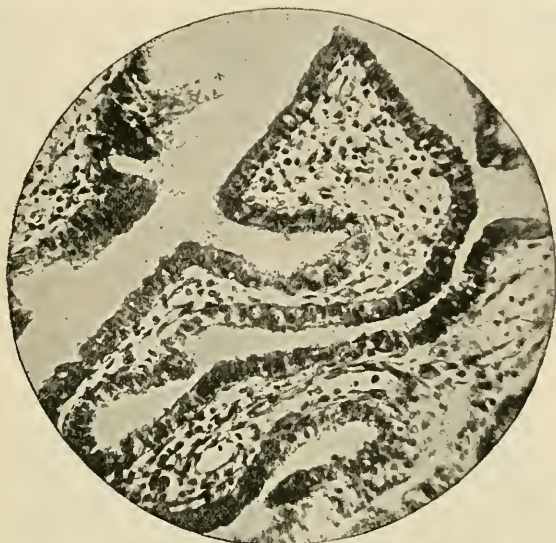

FIG. 196.—Section of a plica (same case as Fig. 195), showing the earlier changes seen in salpingitis. It may be compared with the healthy plica, Fig. 194. Small-celled infiltration has taken place, causing distinct thickening, especially towards the free edge. The epithelium is intact. ( $\frac{1}{2}$  inch objective.) From a woman aged 33, subject to pelvic inflammation for about seven years. The appendages were removed and advanced disease discovered. The portion here seen displays the effect of a recent attack of inflammation over an area which had previously escaped disease.

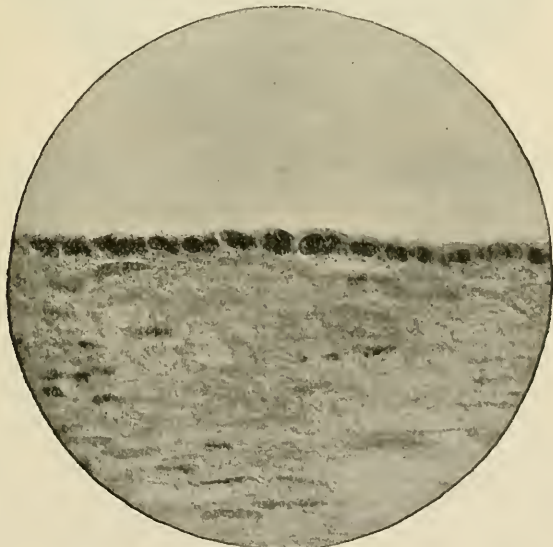

FIG. 197.—Section showing the free surface of the interior of a tube which had been obstructed and dilated for a long period. From a woman aged 42, who had suffered for over ten years from chronic pelvic inflammation. The epithelium has not disappeared, but the cells have become cubical and have lost their cilia. The middle coat is reduced to fibrous tissue; the vessels and muscular fibres have entirely disappeared. ( $\frac{1}{2}$  inch objective.)



little it is subject to primary change in salpingitis. In consequence of the adhesion of the plicæ along their edges spaces, often lined with perfect epithelium, appear in sections. There can be no doubt about the fusion of plicæ; many independent observers have noted it: this being the case there is no mystery about the spaces lined with epithelium; they are in no sense cysts at first, but they often become so after a time, when a long and broad area of plicæ sinks embedded in inflammatory effusion. The observer must not confound this pathological union of plicæ with the normal union of the tips of plicæ sometimes seen in



FIG. 198. — Section of an inflamed tube, in its middle third, showing active inflammation, more advanced than in Fig. 196. The small-celled infiltration is marked, the free edges of the plicæ are much swollen. To the left they are becoming fused and their epithelium is disappearing.

healthy tubes. Nor must the cut-off spaces be taken for the teratological diverticula (Whitridge Williams), not rare in tubes otherwise normal. These diverticula contain healthy plicæ.

In the middle coat œdema, separating the muscular fibres, is very frequent; and the small-celled infiltration is constant. The œdema is the chief factor in obstructing the ostium from within, — the “salpingitic closure of the ostium,” — of which more will be said presently. The inflammatory infiltration may end by organising so as to form fibrous tissue which makes the tube feel tough. The “kinking” of the tube, so often described, is usually a congenital condition, not rarely due to shortness of the mesosalpinx. It is always increased by this sclerosis of the middle coats, and by perimetritic changes without. As the outer or serous coat of the tube is part of the peritoneum, its changes in inflammation are those seen in peritonitis.



The more advanced form of uncomplicated inflammation of the tube should be called purulent salpingitis. Pyosalpinx implies also closure of the tube: in purulent salpingitis the ostium is usually, but not always closed. I have seen pus issuing from the open ostium of a tube not greatly enlarged; this was the case in the specimen from which Fig. 198 was prepared. Hartmann and other observers describe the same appearance.

Under the microscope the plicæ are found thickened by infiltration of round cells (Fig. 199), and reduced in length. The epithelium on



FIG. 199. — The free surface of the interior of a suppurating tube. The plicæ are extremely thickened, but not all fused together. The deeper parts were less vascular than in health; the muscular coat was hypertrophied. From a woman aged 44, subject to symptoms of pelvic inflammation for four years: very severe for four months before operation. Double pyosalpinx was discovered.

the surface is always lost, to a great extent, but deeper down are spaces in which it usually persists (Fig. 200). In short, we see an advanced stage of the changes already described. In part, however, as in Fig. 200, there is evidence of actual breaking down of the diseased plicæ, granulation tissue appearing on the free surface. When pyosalpinx exists the diseased mucous surface is ultimately opened out by the stretching of the walls of the obstructed tube; thus it suffers further damage, and may be entirely reduced to a surface of granulation tissue — to an abscess wall, in fact. Yet experience shows that even in long-standing pyosalpinx the epithelium is not always destroyed.

The plicæ in purulent salpingitis, reduced to low tuberos elevations (Fig. 198), are far less vascular than in health; though a few abnormally thick-walled vessels remain. Many vessels disappear, doubtless through pressure of inflammatory products.

The middle coat is always more or less infiltrated with small cells in purulent salpingitis. Sometimes there is actual hypertrophy of the muscular fibres; more often an increase of connective tissue is observed. In consequence the middle of an affected tube, with its low plicæ and thick walls, often looks like the uterine end of a healthy tube (Fig. 198).

A general atrophy of the affected structures in the tube may and often does follow long-standing inflammation (Fig. 197). More frequently the long-diseased tube shows several stages of inflammatory change simultaneously. A tract of granulation tissue may be bounded on one side by dense cicatricial fibres, showing atrophy of the structures involved; in



FIG. 200. — Section of a suppurating tube, showing advanced disease. Fusion of the plicæ is complete, and much granulation tissue lies on the free surface of the mucosa. The cysts, or pseudo-cysts, representing the spaces between the roots of the plicæ, have not lost all their epithelium. From a woman aged 26, subject for three years to pelvic inflammation. Seven months before the appendages were removed the curette was applied to the uterine cavity. The patient disregarded advice, got up too soon, and an acute attack occurred with high temperature. Both tubes were found full of pus.

another direction it may impinge on plicæ which seem almost healthy, resolution having evidently taken place. I find that these irregular appearances are the rule. Spaces actually cystic are usually observed in advanced salpingitis. Sometimes they seem to be of lymphatic origin. The presence, however, or rather the persistence of epithelium in many of these cysts proves their true nature, which has already been explained.

It is easy to understand why these changes proceed irregularly; for in the clinical history of any chronic case we know that exacerbations are common, and that enforced rest ensures a certain or uncertain degree of amelioration. Subsequent neglect makes matters worse, and the disease once more advances. When a pyosalpinx is established the pus may

not press on the tubal walls with any degree of steadiness; indeed, it may occasionally escape into the uterus, so that for a time the condition which constitutes pyosalpinx ceases to exist. In other cases the pressure may be steady, but the pus degenerates into a watery fluid, and the mucosa and muscular coat into more or less pure fibrous tissue.

In consequence of the irregular course of the inflammatory process the appearances in diseased tubes are very puzzling. Hence intricate forms of classification have been devised, not always on truly scientific principles. The dilated cystic cavities sometimes convert the tube into a strange-looking structure; and when the tube is extremely contorted, it may appear on section to have more than one lumen. Tracts of hypertrophied muscular tissue sometimes present an unusual appearance, but the muscle cells may here represent a new growth rather than an inflammatory product. I shall refer to this subject in my observations on myoma of the tube.

*Changes in the Ostium.*—The abdominal end of the tube is not necessarily obstructed even in chronic salpingitis. I have seen an open ostium in advanced suppurative inflammation, which is one reason why that term must not be used as identical with “pyosalpinx.” In these cases the general peritoneal cavity is protected from the pus by perimetritic bands near the ostium which, though actually open, can only pour its contents into a narrowly limited space.

As a rule, however, the ostium in salpingitis becomes more or less obstructed and more or less permanently closed. The obstruction may arise from without or from within the tube.

To obstruction from without I have applied the term “perimetritic closure of the ostium.” In this condition the outer coat, which is part of the peritoneum, is affected. The adjacent peritoneum may be inflamed before the tubal mucosa is involved. A little deposit covering the delicate fimbriæ as they lie on the surface of the outer aspect of the ovary is sufficient to bind them down, and when the deposit is organised the ostium becomes firmly closed. In ascites, and especially in ruptured ovarian cyst, I have seen the fimbriæ assume the form of chalk-like wattles. This is probably a result of inflammation and of simultaneous deposit of salts from the morbid fluid. Diseased fimbriæ are eminently adapted to receive fibrous deposit (15*g*). Sometimes, on scraping away bands of lymph in the course of an operation, the fimbriæ come in sight, well formed and bright red, being full of blood. In such cases little or no salpingitis may be present. As a rule, however, when its ostium is closed from without in this manner the tube is actually the seat of inflammation; and the perimetritis which causes the closure is the result of extension of inflammatory processes from the tubal canal. This extension protects the peritoneal cavity even more completely when the ostium is directly closed than when it remains patulous, yet cut off from the great serous cavity in the manner explained above.

The accompanying sketch (Fig. 201) represents a characteristic exam-



ple of purely perimetritic closure of the ostium. The well-formed and exuberant fimbriæ were packed in a deep pouch, on the outer side of the ovary, formed by a firm band of membrane. In the drawing the fimbriæ are displayed as they appeared when pulled half out of the pouch. The ostium, before the parts were disturbed, lay deep in the pouch, completely obstructed. The tube was tortuous, being kinked by some firm perimetritic bands; it was also the seat of salpingitis, but the ostium was not closed by changes in the mucosa.

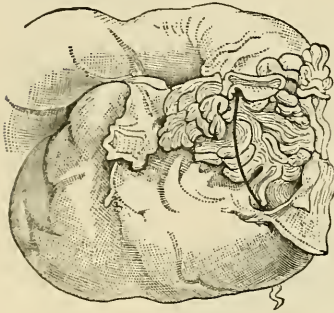

FIG. 201. — Ovary and tube showing obstruction of the ostium by a perimetritic band which forms a deep pouch. The fimbriæ have been partly pulled out of the pouch. A bristle passes into the pouch out of the ostium.

brane and the middle coat become greatly thickened by inflammatory processes already described; they swell and bulge round the ostium, and ultimately close over it. The fimbriæ do not retract like the tentacles of a sea-anemone; the infiltrated tissues simply close over them, till they lie reduced to plicæ inside the tubal canal. A glance at Fig. 202 will show the difference of this form of obstruction from that already described. Around the bristle the thickened tubal walls bulge high, the œdematous ovarian fimbria alone remains outside. The perimetritic bands behind and above the bristle must not be mistaken for fimbriæ. When the bulging structures touch and adhere over the side of the ostium the obstruction becomes very firm.

Owing to the anatomical characters of the part, stricture of the uterine end of the tube, after the manner in which the ostium is so often closed, is impossible. A firm perimetritic band may press on the outside of the tube near the uterus; more frequently the uterine end is closed in salpingitis simply by the swelling of the mucous membrane.

The natural tendency of an obstructed tube is doubtless towards cure by spontaneous relief of the obstruction. The liability of the patient to repeated attacks of pelvic inflammation often prevents spontaneous cure.



FIG. 202. — Tube showing obstruction of the ostium from inflammatory swelling of its coats. The end of the tube has been drawn up from the ovary and the ostium forcibly opened; a bristle lies in its orifice.



Very extensive changes follow chronic obstruction, some of which are described in the chapter on pelvic inflammation. Others, more severe, I will dwell on presently, and show how an inflamed tubal mucosa may become papillomatous; and how the new growths may undergo cancerous degeneration.

Closure of the uterine end by simple swelling of the mucous membrane must obviously be relieved when the swelling subsides; it is not apt to be so permanent as salpingitic or perimetritic closure of the ostium. Temporary subsidence of the swelling of the mucosa at the uterine end fully accounts for "hydrops tubæ profuens." The ostium remains in these cases firmly closed, but the fluid in the tube rushes out of the uterine end and escapes externally.

This condition, termed "hydrops profuens," may be caused by simple hydrosalpinx, by congenital tubo-ovarian cyst ("Ovarian hydrocele" of Bland Sutton), or by growths within the tube, as in No. 5 in the papilloma series, and No. 15 and No. 17 in the cancer series. Great quantities of fluid may escape. The term "hydrops tubæ profuens" indicates rather a symptom than a definite disease. The symptom, as the above observations indicate, may be of grave import.

**Tuberculosis of the Tube.**—This interesting disease has attracted much attention since chronic affections of the appendages have been studied in a scientific manner. For precise information on its essential nature we must rely upon the bacteriologist and authorities on tuberculosis. The affected tissues undergo changes which deserve some consideration in these pages. The proportional frequency of tubercle of the tube has not been accurately determined. The statistics of several living authors show great discrepancies, whether in respect to the proportion of cases detected in long series of autopsies, or in regard to the number of tubercular tubes discovered in operations for the removal of diseased appendages. Of all parts of the female genital tract, the tube, no doubt, is the most often affected.

Tuberculosis may involve the Fallopian tube long before puberty. Dr. W. C. Chaffey has described a case where a child aged four died with tubercle in the lungs and abdominal organs. The Fallopian tubes formed two nodular masses, each about the size of a filbert; the tubal wall bore caseous deposit on its inner aspect. Dr. Quarry Silcock detected a similar condition in a child aged five, who died of tubercular meningitis following cough and otorrhœa; the lungs and peritoneum were also involved, and the Fallopian tubes were enormously distended with caseous material. These two cases are of clinical importance, as they may throw light on the significance of tubercular salpingitis in virgins. Dr. Cullingworth states that tubal disease in the virgin is generally, if not always, tubercular: in such subjects, it is, at any rate, very frequently tubercular, and then often appears as though primary. Nevertheless, as in Chaffey and Silcock's cases, in infancy the patient may have suffered from tubercle elsewhere. An organ primarily involved may recover from the tubercular affection.

A secondary deposit in the tube may presumably remain latent until puberty.

Infection of the tube in a patient already tubercular can well be understood. Jani found the tubercle bacillus in the mucosa of a tube from a patient who had succumbed to chronic phthisis and tubercular disease of the intestine: the tube was perfectly healthy. Thus the specific germ may be widely diffused without necessarily involving every structure to which it pays a visit. The tube may be invaded and infected through the circulatory system. Tuberculosis of the peritoneum and intestines is a well-recognised source of the disease in question. Invasion of the tube from the lower part of the genital tract is rare.

Pathologists seem fairly agreed that the Fallopian tube may be the seat of primary tubercle; but in any suspected case we must bear in mind the qualification made above in reference to Chaffey and Silcock's observations. Martin and Orthmann, writing in 1895, assert their belief in direct infection from without, the vagina and uterus escaping damage from the gerin. The bacilli may be introduced by instruments, by the explorer's finger, and, it is believed, by the seminal fluid in coitus. Whitridge Williams, on the other hand, does not think that it has ever been satisfactorily proven that genital tuberculosis occurs as the result of infection by coitus. Menge's case is attributed to this cause, chiefly on the strength of the fact that the disease appeared shortly after marriage. The husband, it is true, "was known to have genital tuberculosis," but he "refused to be examined." Of course, if the tubercular history had related to himself and to his relatives only, and not to his wife's also, Menge's theory would have been almost proved. I find, however, that Menge admits that the patient's father had succumbed to phthisis, five sisters had died at an early age and were reported as scrofulous; and, above all, the patient was laid up when six years old with ascites and some visceral disease. She had also been subject to swollen glands. This history implies primary infection elsewhere than in the tube. Tubercular pyosalpinx was no doubt detected, and the peritoneum was studded with tubercular deposit. The apparently complete recovery of the patient a few months after the removal of the tubes is no proof that the primary seat of tubercle was extirpated; it is but an interesting example of the disappearance of the symptoms of tubercular peritonitis after simple opening of the abdominal cavity. Penrose and Beyea definitely state that they have detected primary tuberculosis of the tube in three cases, and their diagnosis was made or confirmed on abdominal section. The patients seem to have recovered. Yet, in one or more of these cases, older deposits of tubercle may have existed in other organs.

Dr. Whitridge Williams is the author of the best synoptic work on tuberculosis of the female genital organs. He is wisely cautious about the question of primary infection. "The majority of cases are secondary to tuberculosis elsewhere, and are due either to infection from the blood or the neighbouring organs. Even in the apparently primary cases it is

impossible to exclude blood infection." I agree entirely with Dr. Williams in his cautious decision.

*Pathology.* — Hard as it is, for evident reasons, to procure a tube in the earliest stage of ordinary salpingitis for examination, it is still harder to obtain evidence of the initial changes in the tubal tissues after tubercular infection. The bacillus, as above noted, has been seen in a still healthy tube in a phthisical subject. Schramm gives a good description of incipient salpingitis due to tubercle. I have always found that, with important modifications, advanced cases resemble advanced salpingitis of other kinds. As I find in ordinary inflammation of the tube, the epithelium, according to Schramm, is not shed even when the tubercular disease is already definite. The cells swell and sometimes lose their cilia, but they are slow to fall. The essential primary change is a diffuse cell-growth of lymphoid and epithelioid character in the plicæ, which become greatly swollen. Cheesy metamorphosis of this cell-growth speedily follows, the change beginning in the nuclei of the epithelioid cells. Schramm notes that the epithelium at first appears swollen; and the nucleus, greatly enlarged and spherical, fills up nearly the whole breadth of the cell. This change, however, is precisely what I have seen in ordinary chronic salpingitis. It is represented in Fig. 197, p. 787. The patient in this instance was free from any sign of tubercular disease, and remained so two years after the parts were removed.

When caseation takes place Schramm finds that the epithelium disappears. Thus its destruction is a secondary, and almost a purely passive process, which I make out to be the case in ordinary salpingitis. The diffuse cell-growth invades the muscular coat. The thickening and subsequent breaking down of the infiltrated tissues is a process which is easy to observe; it is seen in tubes where the disease is more advanced than in Schramm's specimens. In Münster and Orthmann's fine drawings of chronic tubercular salpingitis the appearances are much the same as in the chronic non-tubercular form, shown in Fig. 200, p. 790. There are the same cyst-like spaces lined with epithelium. There is, of course, this essential distinction, that the stroma in Münster's specimens is not only subject to small-celled infiltration, as in uncomplicated salpingitis, but it is also infested with giant cells and other characteristic elements of tubercular disease. Thus precise observation shows that both in the earlier and later stages tuberculosis of the tube is, to say the least, intimately allied with salpingitis.

I think that great attention should be paid to Schramm, Münster, and Orthmann's researches; since they show that in the early stage of tubercular disease of the tube it is the mucous membrane and adjacent tissues that are first attacked, and that the disease is inflammatory — in fact a form of salpingitis. Martin and Orthmann find "acute catarrh" in acute tuberculosis of the tube, whilst the chronic form of the same disease, if the ostium be closed, is, according to their researches, practically suppurative salpingitis or pyosalpinx. Whitridge Williams' fifth case is a possible exception; the entire tubal mucous membrane was

studded with miliary tubercles of very small size, but no accompanying inflammatory change could be detected. Perhaps after all this is the earliest stage of tuberculosis of the tube. The specific cell-growth invading the mucosa speedily irritates surrounding tissues, and salpingitis is the result. On the other hand, previous inflammation assuredly renders the tube more liable to be damaged by the tubercle-bacillus. As in tubercular disease of the epididymis and testis, gonorrhœa certainly disposes the tube to infection from the tubercle-bacillus. This subject is familiar to the bacteriologist, and mixed infection has already been recognised.

When tubercular peritonitis exists, invasion of the tube from without is easy to understand. So long as the serous coat alone is involved the disease is tubercle on the tube rather than tubercle of the tube. The deeper coats, however, are soon invaded. I have frequently examined such tubes and never found inflammatory changes absent.

The naked-eye changes are not hard to detect when the tubercular disease is advanced. The tube assumes the characters seen in severe pyosalpinx; its dilated cavity nearly always contains pus. The coats, much thickened, show abundant cheesy deposit. Free adhesions to adjacent structures are the rule. Atrophic fibroid changes have been noted by some writers. The tubercular tube becomes extremely tortuous and, if unobstructed, remains so.

*Symptoms and Diagnosis.* — When a history of tubercle exists diagnosis is not usually difficult; but when chronic inflammation of the appendages occurs in phthisical subjects and in patients with ample evidence of tubercle, the tubes may remain unaffected by the specific germ. Hence salpingitis in tubercular patients must not be recklessly reported as tubercular.

The presence of a tender swelling in one or both lateral fornices in a tubercular subject is fair evidence, I admit, of disease of the tube due to the general infection. Tubercular salpingitis is often, I find, a very chronic disease, less painful than the non-tubercular form. Some writers speak of pain as a special feature; but this, I believe, is due to strong adhesions which interfere with neighbouring organs. Ultimately the condition is the same as in neglected pyosalpinx from other causes, and fistulas discharging pus aggravate the patient's condition. The ill health may at first cause amenorrhœa. As a rule, however, menstruation is profuse and painful, a symptom caused in many instances, I believe, by tubercular changes in the endometrium. T. S. Cullen (9a) finds that "there may or may not be irregularity of menstruation" in the disease which he describes. He finds that it is generally secondary to tuberculosis of the tubes. Ascites is very frequent in tubercular peritonitis; hence when pelvic exploration in a young subject with ascites, not due to visceral disease, exhibits evidence of enlarged or inflamed tubes, these structures are very probably tubercular.

Evidence of gonorrhœal infection added to symptoms and clinical records indicating tubercle of the tube greatly increases the probability



of the latter. In one case where I operated this kind of infection was admitted by the patient's husband, in a second it was self-evident. The pathology of this complication is discussed above.

*Treatment.* — When the disease is apparently confined to the tube the removal of the morbid structure is decidedly indicated. The extirpation of an active focus of tubercle is very advisable.

In more doubtful cases exploratory incision is quite justifiable. In many cases of disseminated tubercle the opening of the peritoneum proves

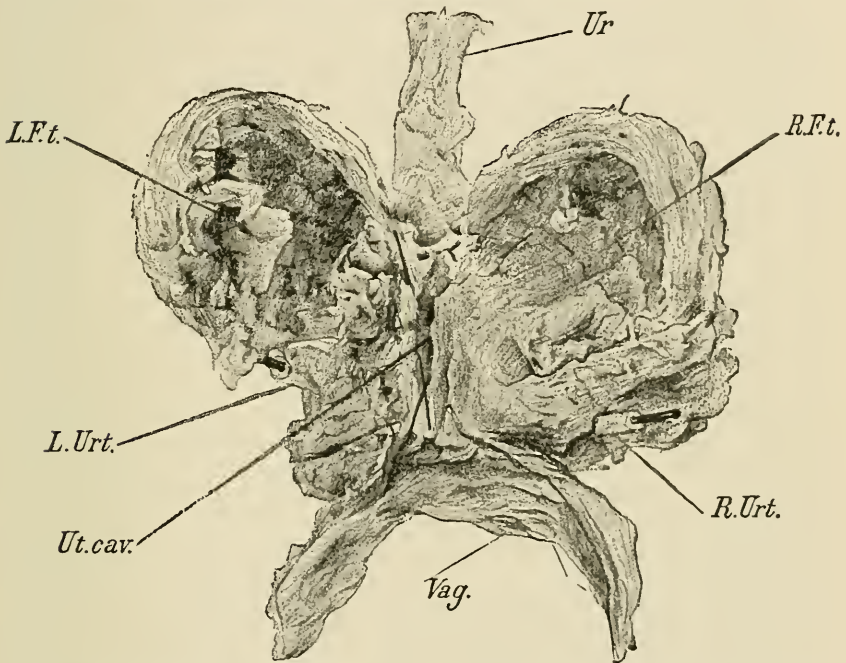

FIG. 203.—Tubes and uterus from a patient who died of phthisis three years after incision of peritoneum infected with tubercle. (See *Trans. Obst. Soc.* vol. xxxi. p. 217, and vol. xxxiii. p. 185.) *R.F.t.*, *L.F.t.*, Right and left Fallopian tubes. *Ut. cav.*, Uterine cavity. A bristle passed into each tube. *R.Urt.*, *L.Urt.*, Right and left ureter. *Vag.*, Upper part of vagina. *Ur.*, Urachus, abnormal.

in itself beneficial. In two cases in which I incised a tubercular peritoneum, but did not remove the diseased appendages, the abdominal symptoms subsided. One patient died of phthisis three years later; the tubes were found diseased, yet in a quiescent condition (Fig. 203). The other is still living, four years after the operation; she presents practically no objective or subjective pelvic symptoms: one knee remains weak from an attack of synovitis which occurred during convalescence from the operation.

**Hydatid Disease of the Tube.** — M. Doléris (*La gynécologie* 1896, p. 97) recently operated on a butcher's wife, successfully removing both her

tubes, which formed a pair of large convoluted tumours stuffed with hydatid cysts.

**Actinomycosis of the Tube.**—This disease has been more talked about than observed, as it was the cause, a few years since, of a dispute between two authors. There can be no doubt that in Zemann's case, so often quoted, the tube was the seat of actinomycosis. Zemann's report is thus summed up by Dr. Illich in his recent monograph on actinomycosis:—

“A cook, aged forty, taken ill with symptoms of peritonitis. Death after meningitis had set in. A few coils of intestine were found bound by a firm and widely diffused deposit to the right tube, which was converted into a sac as thick as a finger, full of pus and lined with granulation tissue containing actinomyces. Metastases in brain, lung, and liver. The author (Zemann) traces the infection to the genitals. Israel suspects that the infection more probably proceeded from the intestine. The deposit above mentioned indicates, in our opinion, the way of infection.” The fungus was only found in the tube, and not in the metastases, a fact which would seem to favour Zemann's opinion. Illich, however (1892), stated that in no case of actinomycosis of the abdomen, published since Zemann's report (1883), has there been the slightest evidence of infection through the genitals. Sir T. Grainger Stewart, nevertheless, writing in 1893, brings forward evidence which we must not disregard. In his case the patient died with symptoms of uræmia, and both ovaries were infected with the parasite; colonies of actinomyces were found in the pus which filled a dilated portion of the right Fallopian tube. Stewart concludes that the mode of entrance was by the vagina and uterus. “The strict localisation of the disease on the right side to the ovary, and the presence of the parasite in the corresponding Fallopian tube, afford practically conclusive proof that the disease had spread along the tube.” In a patient aged thirty-six, under Illich's observation, a mass was felt in Douglas' pouch. An exploratory operation proved disastrous. This seems always to be the case in peritoneal actinomycosis, as the disease is widely diffused before marked symptoms set in. A cyst containing characteristic deposit was found on each side of the uterus. It is not stated whether these cysts were tubal, in fact no mention is made of the tubes. The intestines, liver, and lungs were infected with actinomycosis. [*Vide* art. “Actinomycosis,” *Syst. of Med.*, vol. ii. p. 81.]

Should actinomycosis of the tubes be suspected, he must follow Netter's advice, and prescribe large doses of iodide of potassium. That drug, so useful when the same disease attacks cattle, has cured two cases of actinomycosis of the lung and cæcum respectively in the human subject. Cart of Paris (1894), therefore, maintains that we must trust to iodides rather than to the knife. Choux (1895), though he gives full credit to Netter, is more inclined to rely on surgery than on salts, but he brings forward no clinical evidence to support his preference.

**Fibroma and Enchondroma.**—The existence of a solid tumour of the

tube which can be strictly placed under either of the above denominations is very doubtful. The first term is often loosely applied in works on the pathology of the female organs. By "fibroid" many writers mean not so much a tumour as the disease where a myomatous tumour has developed in the uterus. Hence it is natural that "fibroma," still a purely pathological term, should be sometimes used in error for "fibroid," a word which is now generally used in a clinical sense. By "fibroma of the tube," then, certain writers really mean "myoma," a new growth of which something will presently be said.

On the fimbriae it is not rare to find small, semi-transparent bodies looking and feeling like fragments of cartilage. Bandl states in his text-book that he has observed them: he speaks of them as "connective-tissue growths hard as cartilage." Mr. F. S. Eve has reported more explicitly on a specimen of this kind of growth. "Each nodule contains two, three, or more circumscribed structureless (except for the occasional appearance of faint lamination) yellow masses, apparently in part calcified; the edges of some of the nodules are crenated. The surrounding connective tissue is very rich in large round cells. Of the nature and mode of origin of these masses I can offer no opinion. They are neither cartilage nor bone." The specimen is preserved in the pathological collection at the Museum of the College of Surgeons (No. 4584 A). I believe that they are identical with the very similar bodies found in ordinary papilloma of the ovary, which cause the mass to feel gritty. In examining Sir Spencer Wells' case of papilloma of the tube, a few years before Mr. Eve described the cartilage-like bodies, I found that the cells of the stroma near the apex of a papilla resembled cartilage-cells.

Kossmann and Whitridge Williams may hold that the above facts confirm their opinion that true papilloma of the ovary is derived from tubal elements. They do not confirm the opinion that true enchondroma of the tube has ever been seen.

**Tubal Calculus simulating Tumour.** — I have several times detected small gritty collections of deposit in inflamed tubes, and noticed that the grit often adheres firmly to the mucous membrane. If the deposit happen to lie near the fimbriae, the condition might be confused with the morbid appearances detected by Eve. The truth is, however, that such deposit is not cartilage, nor calcareous matter from a hypothetical degenerating fibroma of the tube. It is essentially calculous in nature. Dr. T. S. Cullen (9a) describes and figures an S-shaped calculus nearly an inch long which he found in an inflamed and obstructed tube.

**Myoma of the Tube.** — Seeing that the tube is morphologically a part of the uterus, and that its walls contain dense layers of muscular tissue, it is perhaps remarkable that it is hard to find authentic cases of myoma.

The uterus has thick walls, and the development of a myoma from a minute spherical body to its well-known advanced forms is familiar and easy to observe. With the tube it is different; the walls are, in absolute measurement, thin. A tumour corresponding to the "interstitial fibroid"

of the uterus must soon spoil the tube by growing inwards and obliterating the canal, or at least rendering it too much deformed to carry on its functions. On the other hand, it may, we can assume, be a "subperitoneal fibroid"; in such a case its growth would not affect the tube so much.

Most of the reported cases of myoma of the tube were pedunculated, that is, of the subperitoneal class. In any of these cases the tumour may have developed from the muscular fibres in the broad ligament at its point of reflexion over the tube, and not from the muscular coat of the tube. Sir J. Y. Simpson's case of fibroid tumour of the tube has been repeatedly quoted. It was "of a size equal to that of a child's head." On inspecting the well-known woodcut in his *Clinical Lectures*, it will be seen that the tumour, which was attached to the upper aspect of the tube by a pedicle several inches long, could hardly have arisen from the walls of the tube, which appear perfectly normal. It is easy to see how a myoma, developing in the broad ligament over the tube, would acquire a pedicle consisting of a part of the ligament itself, and stand out free from the tube. The same observation applies to the drawing in Keating and Coe's recent work, described as "fibro-myoma of tube (Museum of the College of Physicians and Surgeons)." The peduncle is of some length and breadth. No clinical history is given. Schwartz's case seems similar to Simpson's. At the operation a tumour "as big as an egg" was found connected by a pedicle, as thick as a fore-finger, and about one inch long, with the right tube, close to the uterine end. The pedicle was ligatured and divided. The tube itself is reported as normal, and was not removed. The uterus was free from any morbid sign. The patient was fifty-four, and the menopause had not occurred. It is hard to understand how a relatively large tumour, springing from relatively small structure like the tube, could have grown so free from the latter as to render removal possible without the sacrifice of the otherwise healthy structure. But further experience may prove that a myoma developed in the tubal wall does tend to grow outwards till it becomes more or less free from the parent structure, the sole ultimate connection being a band of broad ligament. Such a change is quite different to what is so often seen in subperitoneal uterine myoma, and I doubt if it can ever be authenticated. In Spaeth's and Prochownik's case there was uniform hypertrophy of the muscular coat of the outer part of the tube rather than a true circumscribed tumour. The disease proved to be an oval mass two inches long; the tubal canal passed an inch forward into its substance, ending in a blind extremity; the ostium and fimbriæ were effaced. The patient was thirty-nine years old. Bland Sutton reports a case where an interstitial myoma of the size of a Tangerine orange was found in the walls of a tube at the junction of the uterine and middle thirds.

Lastly, many observers have mistaken collections of tuberculous matter and inflammatory changes in chronic salpingitis for minute myomas. In myoma of the uterus irregular hypertrophy of the



muscular coat of the tube is very frequent; Reymond has recently shown that this condition is associated with inflammation, hence he terms it "nodulo-follicular salpingitis," not "myoma of the tube." The follicular change is at least purely inflammatory.

**Cysts of the Tube.** — The large irregular yellow bullæ so often seen on the surface of the tube in cases of uterine myoma are not true cysts, but dilated lymphatics. When the adjacent tissues are divided during an operation the lymph drains away, and these bullæ disappear. The common broad ligament cyst occasionally develops above the tube, or, more accurately speaking, under the serous coat at the free border of the tube. I have described a characteristic case elsewhere.

The well-known pedunculated cysts which are so frequent near the fimbriæ contain clear fluid and are lined with endothelium. The largest is the pyriform "hydatid of Morgagni"; with its morphology and development we have nothing to do at present: it never forms a large cystic tumour, but I have seen it as large as a Williams pear. I find that it is very apt to undergo hypertrophy when the adjacent structures are diseased. In one case which I have examined its walls had undergone calcareous degeneration. The ovary was cystic, with twisted pedicle. In a case of attempted cure of an ovarian cyst, by drainage and subsequent removal of the cyst, I found that the hydatid of Morgagni was greatly hypertrophied; its pedicle was six inches long, and a vessel of considerable size ramified on its surface. The cyst itself, though so elongated as to measure several inches, was narrow, so that it held but little fluid. Ott figures a "hydatid" several times as large as the adjacent ovary, which was itself "three times the normal size." The "hydatid" has connective-tissue walls with endothelial lining. There was chronic inflammatory disease of the corresponding appendages, and tubal pregnancy on the opposite side. Professor Säger has recently described a most remarkable case, where two masses of cysts and solid growths sprang each from a pedicle which was evidently an abnormal fimbria. He has kindly permitted me to reproduce Dr. Barth's sketch of the specimen, taken when it was fresh. The uterus and opposite appendages were included in the sketch (Fig. 204) so as to display the relations of the tumour. The patient was twenty-six; after delivery an irregular tumour could be seen under the relaxed abdominal walls. Four months later it was removed as it had grown larger. The two fimbriæ were simply ligatured with silk and divided. The left appendages, whence the growths sprang, were replaced, being otherwise perfectly normal, as were the right tube and ovary. The patient recovered and became pregnant again. The masses were of different colours — white, yellow or deep red. The more solid were made up of mucoid tissue, the cysts bore no epi- or endothelium, hence they probably represented a degenerative change, mucoid tissue having broken down. They bore no relation to the "hydatids" common in their neighbourhood. The entire growth was, Säger believes, of congenital origin.

Minute thin-walled cysts are often seen on the surface of the tubal

mucous membrane within the ostium. Their precise pathological import has been much disputed.

**Dermoid Tumours of the Tube.**—Thirty years ago Dr. Ritchie reported a case of tumour in a tube attached to a cystic ovary. The cyst was “as large as a plum; it contained four loculi which were originally filled with a creamy fluid. Each loculus was lined with a serous-looking membrane, studded at intervals with projecting dendritic growths absolutely similar to those so frequently met with in ovarian cysts. Besides this the tumour contained a plate of true bone, one and a half

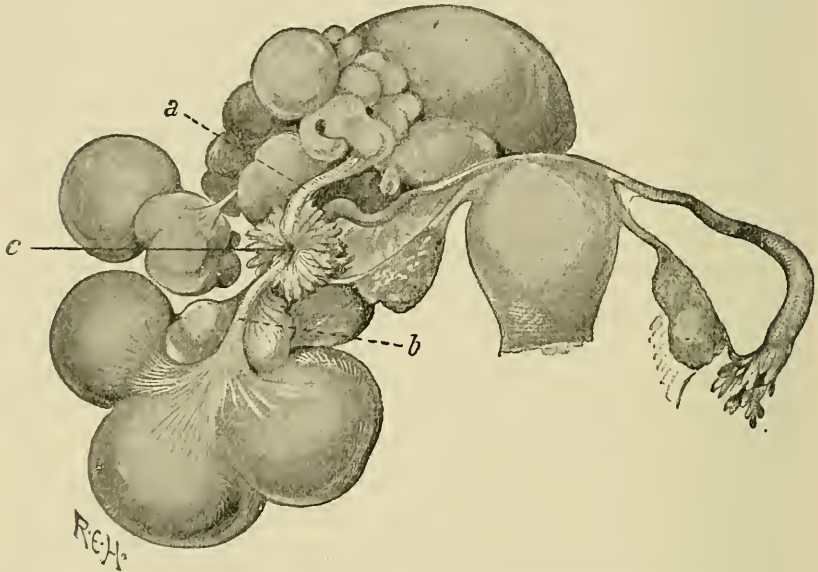

FIG. 204. — Cystic fibromyoma of the fimbriae (Sünger). *a, b*, Fimbriae forming pedicles to the cysts; *c*, ostium of the tube.

inches long by about half an inch broad.” I cannot find out what became of this specimen. Dr. Ritchie called it a dermoid cyst, but his description of its interior suggests papilloma and ossification. “Dendritic growths” are not often associated with dermoid cysts. Treub believes that a tumour which he removed from the tube was dermoid, but it is highly improbable that a dermoid tumour can develop in tubal tissue proper. On the other hand ovarian dermoids have strange peculiarities. I can well conceive how a tumour of that familiar class could contract very intimate adhesions to the tube so as to deceive the observer. Old pus and cheesy matter in the tube may also simulate the greasy material which fills many dermoids.

In short there is no sound evidence that a dermoid tumour of the tube has ever been seen.

**Lipoma of the Tube.**—I have detected true adipose tissue under

the mucous membrane of absolutely healthy tubes in young subjects. There would appear, then, to be no reason why a lipoma should not develop in the substance of the tube, even close to the uterus. On the other hand, it has long been known that a distinct layer of fat is sometimes to be seen between the folds of the broad ligament just below the outermost part of the tube, following the ovarian fimbria. Rokitsansky first recognised this condition. In 1889, in examining a dermoid ovarian cyst, I found a considerable amount of dense granular fat between the layers of the broad ligament (15*e*). In a specimen of papillomatous ovarian cyst, which I removed in 1894, I found an oval fatty tumour hanging by a distinct pedicle from the Fallopian tube close to the root of the ovarian fimbria (15*i*). It measured barely half an inch in long diameter. It arose, I believe, from the broad ligament fat just described, or from an extension of that fat to the subserous tissue of the peritoneum covering the tube.

Parona's case is of some importance: it is too often quoted at second hand. The patient was thirty-seven; removal of the appendages for the relief of a uterine fibroid was undertaken. The left were low down and their removal was difficult: the right ovary and tube bore the lipoma; and as they lay high upon the myomatous uterus they were easily amputated. The lipoma weighed a little under 3 oz., and measured  $3\frac{1}{2}$  inches in long diameter. The ovary, "of normal size and texture," was attached to the tumour by a kind of pedicle formed of two layers of peritoneum which invested the lipoma; the mesosalpinx, in fact, had been opened up. The fimbriated extremity of the tube showed clearly at one end; the tube was partially sunken in the parenchyma of the tumour. On microscopical examination "traces of the wall of the tube with characteristic ciliated epithelium were seen mixed up with the adipose tissue of the lipoma." Parona's own words state that the tube "con adatte sezioni del tumore si trovò *parzialmente sepolta* nel parenchima del esso. Ciò fù accertato con ripetute preparazioni microscopiche mediante le quali si rilevarono tracce di parete dell'ovidotto col caratteristico epitellio vibratile *tramezzo al tessuto adiposo* del lipoma." In an illustration the tube is shown laid open, winding on the surface of the lipoma in which its lower part only is "partially buried." The end of the original quotation just given might imply that the lipoma had really arisen in the substance of the tubal wall. If so, however, the upper or free border of the wall would surely have been invaded, so that the imbedding would be much more complete. I suspect that the fat arose in the folds of the broad ligament, as in my own case, and that it afterwards invaded the tube; but even in that case Parona's expression "*tramezzo al tessuto adiposo*" does not explain whether an entire piece of tube, muscular coat, and epithelium was seen mixed up with the fat, or whether the histological elements of the tube, muscular fibres, and epithelial cells were actually scattered amid the fat cells of the tumour.

**Papilloma of the Fallopian Tube.**—Much diversity of opinion still exists respecting papilloma and cancer of the tube. Only by a patient examination of existing records can we establish the diagnosis and pa-

thology of these important diseases. I therefore feel compelled to introduce the essential part of these records, trusting that my report will not be so brief as to be obscure, nor so long as to be wearisome.

In 1879 I applied the term papilloma to an exuberant morbid growth which lay in the interior<sup>1</sup> of a Fallopian tube. Several observers, especially in Germany (29a), agree with me as to nomenclature. That distinguished pathologist, Mr. Bland Sutton, on the other hand, classes such tumours under "adenoma." Here at once is matter for debate.

In case 3 in the tables I detected patches of the disease in its earliest stages. It appeared as a small wart. The microscope showed (Fig. 205)

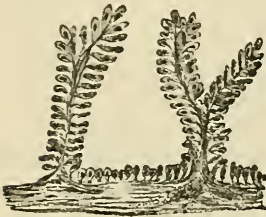

FIG. 205. — Microscopical section of a papillomatous outgrowth from the left tube (case 3). The papillae are very fine, like villi, and bear columnar epithelium; one papilla is branched.

that its structure was essentially papillomatous. The elevations are not glands, nor are they tubal folds. The section was made through a portion of the diseased tube, where the folds had long been effaced. The epithelium of the tubal mucosa, as I have already shown in the observations on salpingitis, is not necessarily shed, even after all the plicæ are effaced (Fig. 197, p. 787). When that change has occurred, as in this and other instances of papilloma of the tube, there may, therefore, remain plenty of epithelium to develop into villi which are essentially epithelial growths.

I made these researches in January 1888, and demonstrated sections at a meeting of the Pathological Society of London a month later. Next year appeared some perfectly independent investigations by Eberth and Kaltenbach (Tables, Carcinoma of Tube No. 3). In examining a tubal growth which proved, clinically at least, to be cancerous, they found that in its earliest stages it was made up of true papillæ. As in my case (No. 3), the papillæ appeared at first sight like villi. In parts the tubal mucosa looked like velvet, owing to collections of numerous long and short branched villi. At more healthy points on the mucosa there were evidences of incipient papillary growths. On microscopical examination the entire process of growth was found to correspond to the development of ridges of papillæ on the skin. The increase of the stroma, or sub-epithelial connective tissue, was secondary, a fact which tallies with my own observations on No. 3 papilloma. This fact must be borne in mind when the opinion that the growth is adenoma, not papilloma, comes to be considered. Zweifel (Tables, Carcinoma No. 6), in 1892, noted that these growths in their earliest stage were villiform; more precisely they began as papillæ, as is above explained. The question of cancerous degeneration will be discussed in the paragraphs on tubal carcinoma.

When I applied the term "papilloma" to case 1, I had in my mind Hennig's observation, made three years earlier, that hyperplasia of the

<sup>1</sup> Papillomatous growths on the serous coat are not included in this class, which is confined to papilloma *in* the tube.



tubal mucous membrane passed into polypoid growth (as in some of the warts in No. 3) through the successive stages of warty and papillary tumours; these transitional forms being often found side by side in dropsical tubes. I had already detected warty growths in a dilated and obstructed tube which, together with the adjacent ovary, had been subject to long-standing inflammation. I believe that these papillomas are allied to the condylomas and warts seen on the external genitals irritated by venereal discharges. Doléris is of precisely the same opinion. In his case, No. 5, Tables of Papilloma, the patient had suffered from a venereal discharge. In No. 1 this complication may be discarded, but the history of pelvic inflammation was distinct. In all the six cases in the tables there is good reason to suspect that the disease was of inflammatory origin, a sequel of salpingitis. Positive evidence is alone wanting in No. 4, Dr. Walter admitting that the earlier history of the patient's illness could not be determined.

Mr. Bland Sutton's opinion that these growths are adenoma is based partly on the theory that true glandular structures exist in the tube, and partly on a painstaking re-examination of the growth in No. 1. That specimen, however, represented an advanced condition. I have already explained that the first stage in the development of a papilloma is represented by a villus or papilla, consisting chiefly of epithelium. The great increase of the stroma, which makes the tumour assume the appearance of a succulent adenoma, is late and quite secondary. Säger and Barth make out two forms of the disease, "simple papilloma" and "cystic vesicular papilloma"; No. 1 being of the second class: but both are held to be essentially papillomatous.

The well-known solid intraeustic ovarian growths are not inflammatory, but are glands which develop in the ovary just as hair and teeth may develop in that organ. Mr. Sutton and myself both believe it reasonable to consider adenomatous non-malignant ovarian cysts as allied to what is understood by the term "dermoids." In any case they are adenomas and not associated with inflammation. I cannot admit unreservedly that papilloma of the ovary is identical with papilloma of the tube; clinically, at any rate, they are distinct, but, according to my observations, both diseases begin as papillæ; hence both are papilloma. Whitridge Williams and, more emphatically, Professor Kossmann declare that papilloma of the ovary is not derived from parovarian relics as Coblenz, Sutton, and myself tend to believe, but from tubal elements (*Nebentubencysten*, parasalpingeal cysts). At present all we have to bear in mind is that these observers admit that papilloma occurs in connection with the tube.

Bland Sutton, like Hennig, believes in the presence of glands in the tube. His arguments will be found in his well-known text-book. I myself was once inclined to accept the gland theory without hesitation. I cannot, however, overlook the fact that some of the most recent observers absolutely deny the existence of any structure corresponding to a gland in the Fallopian tube. Frommel, Whitridge Williams, M. Dixon Jones,

and, quite recently, Martin and Säger in their text-book on Tubal Diseases issued in June 1895, are all more than sceptical about the existence of glands. (See observations on Säger's case of cancer of the tube, No. 8 in Cancer Tables.) Dr. Berry Hart, in the chapter on the Anatomy of the Female Genital Organs in this work, expresses the same doubts. All that I can say in relation to my subject, which is the nature of a certain tumour, is that the scepticism about the presence of glands in the Fallopian tube prevents me from believing without hesitation that the tumour in question is an adenoma. The opinion of so distinguished an author as Bland Sutton must not, however, be set aside lightly. If he be correct adenoma of the tube may occur. Von Recklinghausen denies that the tubal mucosa is furnished with normal glands, but he has detected, chiefly in tubes taken from the bodies of old women who had died of pneumonia, and the like, remarkable glandular structures which he considers to be relics of the Wolffian body. They may be the source of Sutton's adenoma.

The possibility of adenoma developing in the tube cannot affect the evidence which I and others have long since brought forward, that when seen at an early stage the tumour in question is always found to consist of a papilla or villus. Thus Fig. 205 could not be a morbid development from one of Bland Sutton's glandular diverticula. Therefore I shall retain the term "papilloma."

There are two features of high interest in association with papilloma of the tube. The disease is known to assume characters apparently malignant, though the after history, when the diseased part is removed, may prove the new growth to be innocent. It seems equally certain that if left alone the papilloma will undergo malignant degeneration. In the second place remarkable symptoms have been observed, as result of discharge from the growths in instances where the ostium or the uterine end has remained unobstructed. I have tabulated six cases which have been under close observation. In two (Nos. 1 and 4), the ostium was open and the peritoneum was full of fluid. In one (No. 5), the ostium was closed and the uterine end patent; very free watery discharge escaped through the vagina in consequence. In two (Nos. 2 and 3), the tube was closed at both ends, and there was neither ascites nor discharge. No. 6 resembled Nos. 1 and 4, the ostium being open, but there was no ascites.

No. 1 was a patient of Mr. Bickersteth's of Liverpool, and Sir Spencer Wells operated. I published the history, with a full pathological report in 1879, and issued notes of the after history seven years later. This is the case to which I referred at the beginning of these observations on papilloma of the tube. The great feature of interest is the gloomy clinical aspect of the case before and during operation in 1879, as compared with the after history. For, in spite of ominous pleural and peritoneal effusions containing ugly-looking cells, and notwithstanding the presence of an exuberant new growth, and the impossibility of cutting through the Fallopian tube, at the operation, far beyond the limits of the

growth, no recurrence occurred. Schroeder in 1886 maintained that this case was evidently malignant. (See also observations on No. 3 in the Tables of Cancer of the Tube.) On 14th November 1895, Mr. Bickersteth wrote to me saying, "Miss — called on me a few days ago, and I never saw her looking better."

The patient was first seen by Mr. Bickersteth in October 1877. She then had symptoms of inflammation of the right ovary following menorrhagia, which subsided after rest. This history of inflammation must be borne in mind; it is common to all the cases of papilloma (except that in No. 4 it was not noted), and the relation of this morbid growth to inflammation has already been discussed. The clinical and pathological relations of adenoma are different. In March 1878 the patient had an attack of pleural effusion on the right side; 120 ounces of clear fluid were removed by tapping. In July, 9 pints of fluid were drawn off from the abdomen, which had become swollen. In September, 13 pints were removed from the abdomen. In October, 100 ounces were drawn off on tapping the right pleura. In January 1879, the abdomen was tapped a third time and 16 pints were drawn off. These accumulations of fluid and the five tapplings were not accompanied by rise of temperature or systematic disturbance. There were no signs of cardiac, hepatic, or renal disease.

In March 1879, when the patient, a thin and emaciated maiden lady, was fifty years of age, Sir Spencer Wells first saw her. As she objected to an exploratory incision the abdomen was tapped for the fourth time, and 22 pints of fluid were removed. The specific gravity of the fluid was 1022, and it coagulated almost entirely under the action of heat and nitric acid. Its scanty flocculent deposit was found to consist of large cells, mostly grouped in clusters and apparently proliferating; many were distinctly vacuolated: similar cells had been found in the pleural fluid. I examined some of these cells, and never saw any structure in morbid fluids that more thoroughly suggested malignancy; and at that date I was examining ascitic and cystic fluids many times a week. Since then I have ceased to trust the evidence of solitary cells in the diagnosis of malignancy. The incident of effusion will be considered in association with one of the conditions detected after the operation.

The uterus was movable, and so low in the pelvis that the cervix lay close to the vulva; behind that organ a hard nodular mass could be detected. On April 28, 1879, Sir Spencer Wells operated. The peritoneal cavity contained 17 pints of amber-coloured fluid. A tumour of the size of a large orange lay to the right of the uterus; it was removed together with the right ovary. No secondary deposits could be found on the peritoneum, notwithstanding the most careful search. Recovery was rapid. The patient suffered from an attack of pleurisy four months later without any effusion. Menstruation had ceased for over two months before operation; one tube and ovary, be it remembered, were not removed. As has been already observed, the patient was well in the autumn of 1895, sixteen years after the operation.



The tumour, now in the Museum of the Royal College of Surgeons (Path. Series, No. 4584) consists of the Fallopian tube, extremely dilated, with the ovary, unaffected, beneath it. The uterine end admitted a bristle which could be passed through the entire tube and out of the ostium. The fimbriæ, short and thick, were still to be seen; the ostium was abnormally patulous. Cauliflower excrescences sprouted from all parts of the mucous membrane; they were covered with a mucoid material which issued from the ostium.



FIG. 206. — Papilloma of the Fallopian tube. Case 1. The tubal wall has been divided along its upper border and turned back, exposing the papillomatous masses springing from the mucous membrane. A bristle, entering the cut uterine end, passes along the tube amidst the growths, and emerges at *b*, the ostium. The tube is undilated as far as *a*; *c*, ovary; *d*, small pedunculated cyst; *e*, cyst developed amidst the papillomatous growths.

Here I must pause to consider the pleural and peritoneal effusions in this non-malignant case. So far as innocent ovarian tumours are concerned, M. Demons of Bordeaux has published researches of great value. He has seen pleural effusion in 9 out of 50 cases of common ovarian cyst. One of his patients had an ovarian tumour on the right side and free effusion into both pleuræ. Cancer was reasonably suspected, as in the case of tubal disease now under consideration. The pleura was tapped several times on both sides; but the fluid rapidly re-accumulated and the health began to fail. Demons did ovariectomy, the double effusion disappeared "like magic" and never returned. He attributes



the pleural effusion to lymphatic obstruction due to the interference of the tumour with the circulation in the abdominal lymphatics, which arrest extends through the diaphragm to the lymphatics of the pleura. In other cases Demons observed more or less abundant ascites. Verneuil believes in the lymphatic obstruction theory.

In this case of papilloma the existence of lymphatic obstruction is hard, if not impossible, to detect. I found that free mucoid material issued from the ostium. As in this case 1 in the tables, so in case 4 there was ascites; in both the ostium was open. Hence it is reasonable to believe that some irritation from the discharge set up the effusion. The big cells indicated more than lymphatic obstruction. Lucas-Championnière, in the discussion on Demons' communication, stated that he found pleural effusion with or without ascites most frequent in cases of proliferating abdominal tumours. I have operated on free papilloma of the ovary, where abundant ascites existed, the effusion disappearing permanently afterwards; hence, I fancy that the effusion is due to irritation of some sort. The papillomas in one of my cases seemed too small to obstruct anything. In the tubal case both the peritoneum and one pleural cavity suffered from this irritation, but as the phenomenon of abdominal tumour with pleural yet without peritoneal effusion did not occur in this case, it need not be discussed here.

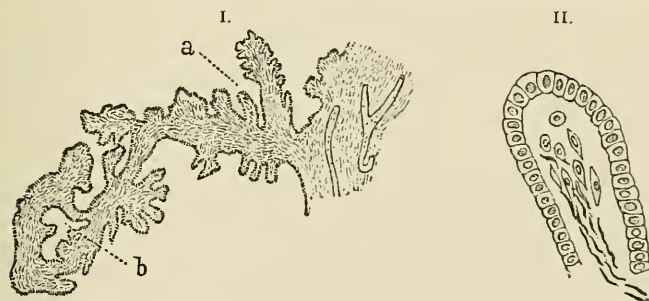

FIG. 207.—Papilloma of the Fallopian tube. Case 1. Sections of an outgrowth under a high and a low power. *a*, Papilla, the same which is shown more highly magnified; *b*, space lined with epithelium.

I have minutely described elsewhere the microscopic appearances of this growth. A layer of columnar epithelium invested the whole of the outgrowths which made up the tumour. It was ciliated at certain points, and nowhere invaded the stroma.

The arguments in support of my original opinion that the new growth was in this case a true papilloma rather than an adenoma, have been given at the beginning of these paragraphs on the subject. Secondary increase of the stroma may fully account for the appearances in this tumour. It may account for the large cystic spaces lined with epithelium which I discovered in the stroma (Fig. 207. *b*). The papilla developed, I believe, as a result of salpingitis. The spaces would in that case be identical with those which so often develop when the

tubal mucosa becomes inflamed; the manner in which they form has been already explained (see p. 788, and Fig. 200). Bland Sutton compares the tumour-substance with the normal tubal mucosa in a macaque monkey. As there is still more stroma in the macaque's tube in health,<sup>1</sup> this resemblance would imply, not that the tumour was an adenoma, but rather that it was a pure hypertrophy.

The clinical features of case 2 are sufficiently explained in the appended tables. I assisted at the operation, and plainly saw that it was a Fallopian tube that was removed. The ostium was closed. The cavity was stuffed with rather gritty papillomatous masses. Unfortunately this valuable specimen was accidentally lost.

Case 3 is very suggestive. At the beginning of these observations I have noted that the new growth could be detected in its incipient form as a papilla (Fig. 205, p. 804). The ovaries and tubes had undergone simultaneous cystic degeneration, the result of long-standing inflammatory disease; and papilloma had begun to develop on their inner walls. I fully discussed these changes in the paper referred to in the tables, and I shall again refer to this case in speaking of Warnek's example of tubal cancer (No. 12, Tables of Cancer of Tube).

The fourth case was originally recorded by Bland Sutton. Dr. Walter informs me that the patient did not recover from the operation. Mr. Sutton has given a description of the microscopical appearances of the growth, which he considers to be an adenoma. I must, however, dwell on one sentence in his observations; namely, that "the specimen differed from Doran's case in that it contained a far larger proportion of stroma." Hence it may have been of older growth. As in No. 1, there is no evidence as to what the earliest appearances of the growth might have been. The ascites and patulous ostium cause No. 4 to resemble No. 1.

In case 5 the patient was a public singer of irregular habits. There was a long history of vaginal discharge, attacks of pelvic inflammation, carelessness of advice, and immoderate sexual indulgence. In May 1888, when straining at stool, a great quantity of sero-sanguineous fluid escaped from the vagina. The discharge continued for six days, often drenching the patient's clothes. Several quarts came away. A week later the period occurred and lasted six days, then the free discharge recommenced. The pains, which had been severe, subsided. The abdomen was almost flat throughout. (Nos. 15 and 17 in the Cancer Tables presented these remarkable symptoms of "hydrops profluens.") On examination a swelling was found in each fornix; serous fluid was seen to issue freely from the os uteri. The tubes could not be catheterised. Eleven months after this examination, the serous discharge having become very free, M. Doléris operated. The left appendages were removed; they were much altered by chronic inflammation. On the

<sup>1</sup> Here we must be careful in verifying Mr. Sutton's researches, lest the tubes of quadrupana selected for examination as normal be really diseased. Monkeys in captivity are very often sickly, their well-known sterility and still better known sexual irritability both lead us to suspect that disease of the genital tract must be frequent.

right side was a tumour adherent to intestine, omentum, and the pelvic wall. Its surface was pearly white. After removal it was found to consist of the right Fallopian tube. From its inner wall grew masses of arborescent vegetations of the kind usually observed in papilloma. There was a central part of vascular connective tissue, and a layer of epithelium on the surface. At certain points these cells, which were cylindrical, were arranged in double or triple layers which the pathologists reported as suggesting malignancy. The ostium was closed, the uterine end remained relatively narrow, bearing no papillomatous growths, but the canal was patent and dilated. The operation was performed in July 1889. Doléris informed me, in a letter dated 23rd October 1894, that there had been no recurrence, and that the patient was in very good health. In a less marked case of intra-tubal papilloma in his practice the result had proved equally satisfactory.

The remarkable symptom which was so prominent in this case is evidently identical with the "hydrops tubæ profluens" of old writers, though watery discharge may occur in simple hydrosalpinx. Indeed, case 1 was an instance of the same phenomenon, save that the fluid discharged itself into the peritoneal cavity and not externally.

Case 6 fortunately came under the observation of a competent observer, Mr. Bland Sutton, who was also the operator. The patient had been subject to pelvic pain and menorrhagia for some time. "The right tube was enlarged to the size of a finger; the ostium was open, the walls greatly thickened, and its interior stuffed with adenomatous masses in structure resembling those found in Doran's specimen (No. 1). There was no hydroperitoneum or watery discharges from the vagina." Thus Sutton's valuable report shows that in papilloma of the tube with patulous ostium peritoneal effusion is not always present. On the strength of his evidence I have refrained from generalising on this rare disease; it shows, at least, that one important clinical symptom was absent in 1 out of 3 similar cases (Nos. 1, 4, and 6). The left tube in case 6 was strangulated by an adhesion between the ovary and intestine; it did not bear papillomas. The patient, Mr. Sutton kindly informs me, was living nearly four years after the operation.

Since the above notes were prepared, Godart (19a) has described a case where abdominal section was performed for symptoms of pelvic inflammation in a woman aged 32. In a dilatation, as big as a walnut, in one tube, there was a papillomatous mass consisting of hypertrophied plicæ. He looked upon it as a purely inflammatory condition, not a new growth, a distinction which I have already discussed.

*Treatment.*—The clinical and pathological evidence above given indicates but one line of treatment, removal of the diseased tube. The ovary must be removed with it. The ligature should be tied close to the uterus, and if papillomatous growths are seen on the exposed mucosa of the stump they should be destroyed with the thermo-cautery. Prognosis must be guarded even after a successful operation. No doubt the after history in case 1 is most encouraging, but it will be seen that



the distinction between papilloma and cancer is not by any means easy.

**Cancer of the Fallopian Tubes.**—There can be no doubt that the Fallopian tube may be the seat of primary cancer. Until a few years ago it was asserted in text-books that authors were agreed that cancer of the tube is always secondary. Since attention was first turned to the subject, cases of alleged primary cancer, not always indisputable, have been published from time to time by clinical and pathological observers.

Those who speak of tubal cancer as always "secondary" are further incorrect in that they usually mean to imply simple extension of malignant disease from the uterus or ovary. A good instance of this extension of cancer from the uterus is described and figured in Sir John Williams' *Harveian Lectures*. Drs. Ballantyne and Williams record an interesting case of cancer of the tube, which they are inclined to consider as "secondary," in the true pathological signification of the term. Scanzoni's case is sometimes reported as primary tubal cancer. I believe that it began in the ovary, as that organ was "of the size of a fist," whilst the tube was only "of the thickness of man's thumb." This proportion is reversed in No. 2 in the appended tables. Scanzoni observes that his case proves that cancer of the tubes does not always arise from the contiguity of those organs to diseased neighbouring structures. It seems likely that the tube was affected with true secondary cancer.

In cancer of the ovaries the tubes, as a rule, are not involved till very late, if at all. I have repeatedly seen the tube quite healthy when the corresponding ovary had become a large sarcomatous or carcinomatous tumour. Schroeder and Ballantyne and Williams note this clinical fact. Sanger (41, Fig. 53) describes a case of cancer of the ovaries extending to the tubes, which remained quite small though distinctly infected. Extension of cancer from the uterus to the tube is not common.

Since Dr. Orthmann described Dr. Martin's case (No. 1) over a dozen instances of primary cancer of the tube have been described.<sup>1</sup> Two forms may be distinguished: in the first, carcinoma develops in the mucous membrane of a normally formed tube; in the second it develops in a tube which is malformed, bearing a cyst (not connected with the ovary) into which the ostium opens. The cyst wall becomes infected.

1. *Primary Cancer of a normally developed Fallopian Tube.*—In May 1888, I stated at a meeting of the Pathological Society "that malignant disease of the tube may result from a degeneration of papillomata of the tubal mucous membrane." This remark was in reference to the specimen (case No. 2) which I then exhibited. Since that date this opinion has been confirmed by other writers who have examined other specimens. I have already shown that papilloma tends to degenerate into carcinoma (p. 806); I may now add that it is not easy to distinguish papilloma of

<sup>1</sup> Dr. Renaud of Manchester, in an Atlas of unpublished pathological drawings, now in the Library of the Museum of the College of Surgeons, figures a specimen of "medullary cancer of the right and left oviduct, also of right and left ovaries." The date is November 1847. As far as can be judged from a drawing the disease appears to have originated in the tubes



the tube from carcinoma. Landau and Rheinstein (No. 5) discuss the histology of those new growths very carefully. The column "Character of the Tumour" in the tables shows how frequently the supposed cancer was papillomatous, at least in appearance (Nos. 1, 3, 4, 6, 7, 8, 9, 10, 12, 13, 14, 15). The distinction between "villous" and papillomatous" must remain doubtful. The actual origin of these papillomas from papillæ, described at page 804, must be carefully borne in mind when any case of cancer is considered. I have given reasons for believing that the morbid papillæ develop on the mucosa of tubes subject to chronic inflammation.<sup>1</sup> Hence, in the tubes, cancer seems to be a distant sequel of inflammation. The "Chief Symptoms" column in the Tables of Papilloma and Carcinoma tends to confirm this theory.

The appended tables are based on a more limited compilation which I prepared for my second report of case 2. It has been extended by Dr. Fearn and by Sanger and Barth. I here add fresh cases and additional information<sup>2</sup> respecting recurrence and other matters on cases already reported. For such information I must thank the gentlemen after whose names, in the "Reporter and Reference" column, I have added the words "private correspondence." These words will serve to explain how certain facts not in the original printed records came to be inserted in the tables.

In case 1 there is a long history of pelvic inflammation, following an attack of typhoid fever one year and a half before operation; but the inflammation may have arisen from abortion a little previous to the fever. The mucous membrane of the tube was covered with soft papillomatous growths filling the lumen of the abdominal end, where they were numerous. Each growth consisted of a stroma or connective tissue, including numerous nests of epithelial cells. Here and there involutions of epithelium were detected passing into the stroma.<sup>3</sup>

I was present at the operation upon No. 2, and made a minute examination of the diseased tube. I was also enabled to inspect the pelvic viscera after the patient's death from recurrence. The specimen is preserved in the Museum of the Royal College of Surgeons, No. 4584 D.

At the operation the infected ovary, much smaller than the diseased tube, was found strongly adherent to adjacent structures; the examination of the pelvic viscera ten months later showed that none or very little of the ovary was left behind, as the operator feared at the time. The uterus was quite healthy. The cancerous tube measured five inches in length when collapsed. It contained several drachms of ill-smelling, bloody serum with minute solid fragments. This fluid closely resembled the vaginal discharge which Dr. Amand Routh, who attended the case

<sup>1</sup> See especially the observations No. 3 in Tables of Papilloma of the Tube.

<sup>2</sup> Thus in Sanger and Barth's tables there is no note under Kaltenbach's case (No. 3 in my tables) that recurrence took place.

<sup>3</sup> See the fine microscopic drawings in Orthmann's original paper (reference, No. 1 in tables).

before operation, had already observed. Almost the entire mucous membrane was covered with a soft and highly villous growth of a bright red colour when fresh. No trace of ostium or fimbriæ could be found. The ovary was almost spherical, and measured in its long diameter about one inch and three-quarters. No normal ovarian tissue remained.

The microscope showed that the new growth in the tube consisted of large polymorphous cells. They formed clusters bounded by trabeculæ, in which the connective-tissue cells were undergoing proliferation

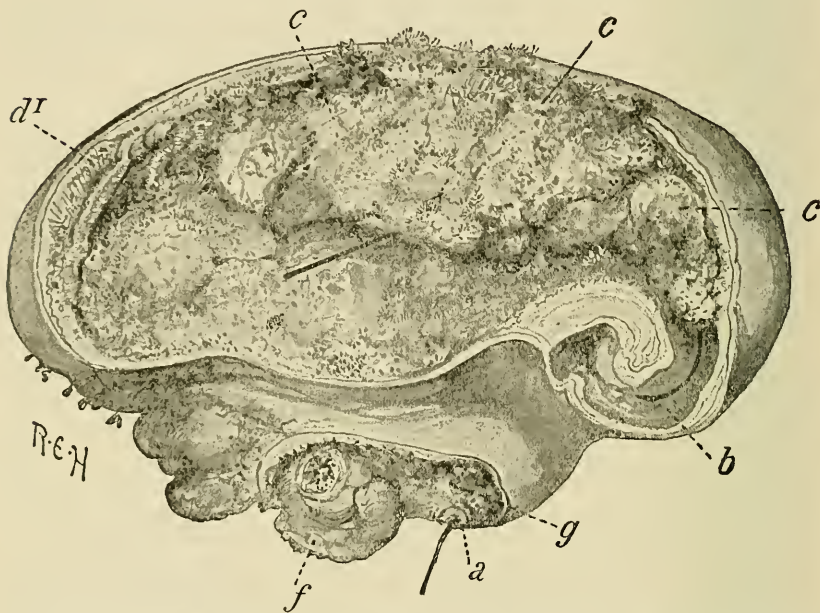

FIG. 208. — Primary cancer of Fallopian tube. Case 2. *a*, Uterine end of tube divided at the operation. A black bristle has been passed through it along the channel of the tube. *b*, Portion of the tube near the uterine end free from growths; *c, c, c*, masses of cancerous growth springing from the inner surface of the tube; *d*, new growth invading the muscular coat, which is elsewhere mostly free from disease; *f*, ovary converted into a mass of tumour substance; *g*, cut surface of broad ligament, which is infiltrated with new growth.

(Fig. 209). In the deeper parts I noted some well-formed tubules lined with perfect columnar ciliated epithelium and surrounded by a wide area of large cells. The precise significance of these tubules is not at first sight clear. Senger, in his case of sarcoma (No. 1, Sarcoma Tables), detected tubes lined with cylindrical epithelium in the tumour substance, and traced them, as Von Recklinghausen would do, to the parovarium. Sænger in commenting on Senger's case, insists that such "tubes are not glands, as Senger maintains, but simply outrunners from normal plieæ or from papillomatous growths. Eberth and Kaltenbach have already noted these false tubes. Hence these "tubules" are possibly homologous to the "cysts" lined with epithelium, on which I dwelt in my observations

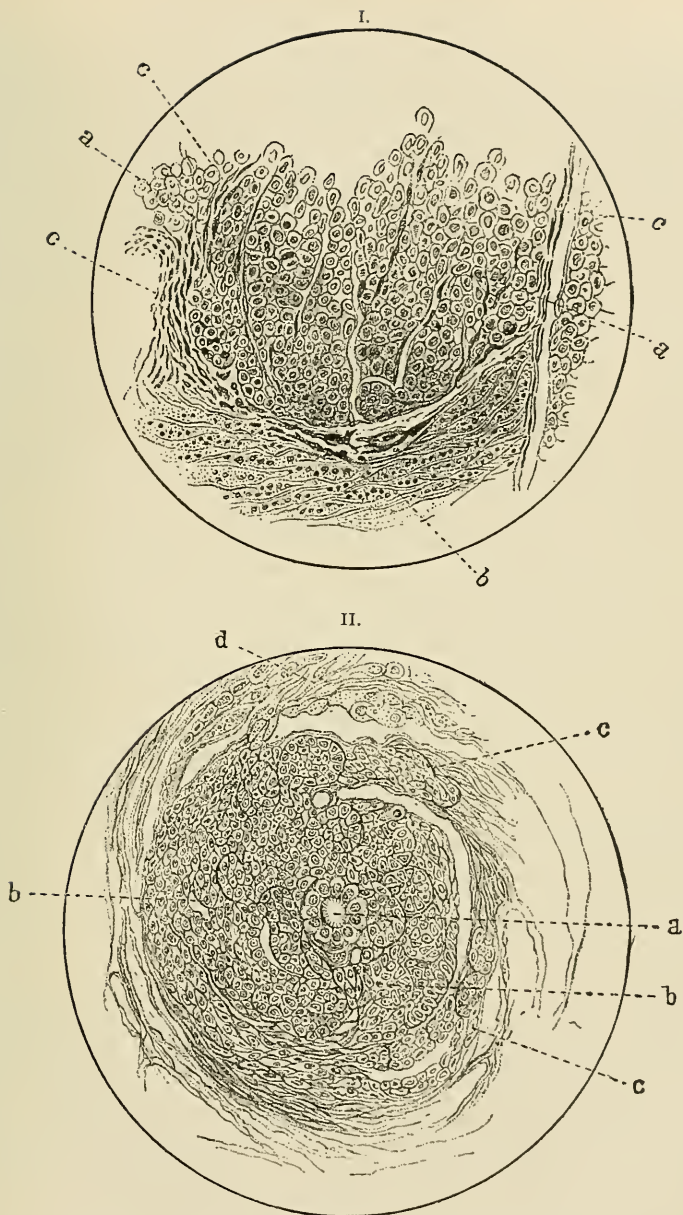

FIG. 209. — Primary cancer of Fallopian tube.

- I. Section of cancerous growth invading the wall of the tube ( $\frac{1}{4}$  inch objective). *a, a*, Large polymorphous cells; *b*, part of a trabecula, bounding the group of cells, showing small cell infiltration; *c, c, c*, muscle-cells indicating remains of the muscular coat of tube.
- II. Tubule-like structure *a*, seen in cancerous growth (see text). It is lined with cylindrical ciliated epithelium. Large cells, *b, b*, surround the tubules; they are arranged somewhat spirally, and prolonged outwards into the stroma at *c, c*. Farther on, at *d*, are larger cells.



on salpingitis. Possibly again, the tubules may be Wolffian relics, such as Von Recklinghausen has recently described. Fabricius (17*a*) believes in involutions and outrunners from the tubal mucosa. He has traced them to the serous coat. In short, there are several probable explanations of the origin of the tubules in Fig. 209, but it is not clear which is correct.

The ovary seemed to be made up of the collections of large cells bounded by trabeculæ as in the tubal growth. The disease seems clearly to have originated in the tube, where it was more advanced than in the ovary. The clinical symptoms before operation all indicated not ovarian tumour, but tubal disease.

The patient died from recurrence nearly eleven months after the operation. Dr. Amand Routh kindly brought me the pelvic viscera for inspection, and I published my report. The surface of the cervical canal and the endometrium bore numerous slightly elevated white spots representing secondary deposit; otherwise the uterus, though rather bulky, was normal. A spherical mass of cancer, not one inch in diameter, lay to the right of the cervix in Douglas' pouch, in a situation corresponding to the point of adhesion of the diseased ovary.

No. 3 shows how difficult it is to distinguish a malignant papillary carcinoma from an innocent papilloma of the tube. I have shown how No. 1, in the Tables of Papilloma, looked very malignant, yet proved innocent. The present case was described by Professor Kaltenbach in a society report as "primary bilateral tubal cancer." Shortly afterwards I published the sequel or post-mortem report of case 2. I stated that Kaltenbach's case appeared "to represent simultaneous cancerous degeneration of papillomatous tubes." A few months later the deceased professor, in conjunction with Dr. Eberth, issued a complete report of the pathological appearances of the tubes. They traced the growth from its beginning as papillæ springing from the mucosa, as I did, in the case of No. 3, Tables of Papilloma, at the very same time. These "independent researches" are discussed at page 804. They went farther, and declared that they could in no part of the growth detect any invasion of the stroma of the papillæ by the epithelium, that is to say, any true cancerous process.

Unfortunately the disease recurred after this careful report was published. In reply to inquiries, Professor von Herff, Kaltenbach's successor, informed me last year that the patient was readmitted into hospital, and extensive recurrence was detected. "She could hardly have lived much longer, but I could not obtain further information." (See Tables, No. 3.) Either Kaltenbach overlooked an area of cancerous degeneration, and thus failed to include it in his microscopic sections, or more probably, some papillomatous tissue, left behind after operation, became malignant.

Sänger and Barth observe in their work that Eberth and Kaltenbach considered that the tumour in question was malignant, and that "Doran classes it without further discussion under Cancer"; at pages 265, 266 they still write doubtfully as to the malignancy of the same



tumour. But in their tables, under the heading "Result of Operation," I find, "Still quite well three-quarters of a year later." It is fortunate that I applied to Professor von Herff; the consequence is that I have added, under the same heading, "Recurrence within eighteen months,"—most important evidence in relation to the malignancy question.

On the other hand, No. 4 was described as "a case of carcinoma of the tube," at a meeting of the Berlin Obstetrical Society, 14th December 1888. Professor Veit removed it in September of that year. There was pyosalpinx; the inner surface of the tube was studded with abundant small growths, and microscopic examination of the latter plainly demonstrated carcinoma. Professor Veit, however, informs me that the patient was free from recurrence and in excellent health seven years later. Hence either the papillomatous growths were malignant in appearance only, or else the distinguished professor extirpated a cancer very thoroughly.

No. 5 is the subject of an excellent monograph, where the opinions of Kaltenbach and myself on papilloma are impartially considered. Landau and Rheinstein, the authors, are, however, too sanguine when they infer that papillomatous growths in the tube are "not to be reckoned amongst malignant tumours." They rely on an observation of their own and on the history of my own cases (Nos. 1 and 3, Tables of Papilloma). No. 3 in the Cancer Table, however, proves that a papilloma of the tube is always suspicious. Landau's case appeared to be an instance of medullary cancer; he gives a good drawing of a section. As in case 2 the disease was advanced; it most likely represented a growth originally papillomatous. Recurrence was less rapid than might have been expected in so clearly malignant a growth.

No. 6 was carefully examined by Professor Zweifel. At first sight sections viewed under the microscope seemed to indicate sarcoma; but the cells with very large nuclei, which lay in groups in alveoli amidst the stroma, were traced to the epithelium of the tube. Zweifel comments on the great resemblance between the new growth in his case and that which I described as No. 1 in the Tables of Papilloma. The latter would have had the fate of the former, we may fairly assume, had operation been delayed. Zweifel, less fortunate than Spencer Wells, had the disadvantage of operating when the disease was advanced and bilateral.

No. 7 has frequently been quoted from second-hand sources, the original record being published in a Scandinavian medical serial. The authors give excellent reasons for believing that the morbid growth was a papillomatous cancer; they maintain that the infection of the right ovary was secondary, quoting my observations concerning infection of the tube in primary ovarian cancer (see p. 812).

Professor Sanger removed a papillary cancer of the right tube "as big as a goose's egg" (No. 8). The patient was forty-five; and, as in Thornton's case, there was a history of menorrhagia. The uterus was dilated and explored, but found to be free from any new growth. Shortly afterwards abdominal section was performed, and the right tube was found

occluded at its abdominal end and cancerous; but between the infected part and the uterus was an inch and a half of tube free from cancer, but subject to chronic inflammation. The growth seems to have advanced slowly; and Professor Säger considered it to be a papilloma which had undergone malignant degeneration. The patient was in good health and free from recurrence seven months after the operation. The operator has published a complete report of this case, with good microscopic drawings. His opinions on the papillary origin of the growth are in accordance with my own; and in this case there was a history of old inflammation, which may indicate that the papilloma was a product of inflammation. As for the appearances of the malignant changes in the growth in case 8, he admits that they reminded him strongly of malignant adenoma of the uterus and papillary adeno-carcinoma of the ovary (*loc. cit.* p. 257); but he cannot consider that the growth No. 8 is homologous to uterine and ovarian tumours of the varieties just noted, as he is by no means certain that gland-like structures are to be found in the tube.

No. 9 is excellently described by Dr. Fearn. His microscopic researches support my views that papilloma of the tube is truly papillomatous from the first; that this growth tends to develop in tubes subject to chronic inflammation, and that, as in No. 9, it may undergo malignant degeneration. According to his drawing of the diseased tube, it looks very like that in No. 2 (see Fig. 206). Though he describes the growth as "heteroplasmic throughout," the patient, Professor Leopold informs me, showed no sign of recurrence a year and seven months after the operation.

In No. 10 it is to be regretted that no note was made of the condition of the right ovary. The sequel, however, showed that the ovary could not have been cancerous, as the patient, MM. Tuffier and Hartmann inform me, was free from recurrence a year after the operation.

Case 11 occurred in Dr. Cullingworth's practice, and has been fully described. In October 1894 the operator and Mr. Shattock kindly allowed me to examine the specimen.

The tube measured a little under three inches. It was shaped like a gherkin, with a large prominence (Fig. 210, *a*) externally. Its walls were very thick; the lumen wide for the first two inches, then lost, so that it was uncertain whether it went into the prominence *a*, or ended near *b*. No trace of a fimbriated extremity could be seen. The inner wall was very irregular, and at points (*c, c*) there seemed to be a smooth membrane over the new growth in the walls. This new growth was spongy on section, exposing irregular cavities; minute papillary growths sprouted inside these cavities. Mr. Shattock compared this intra-tubal cystic growth to what is seen in duct-cancer of the breast. The mesosalpinx was opened up, so that the tube lay on the ovary, which was converted into a cyst. On the surface of this cyst were some small papillary masses similar to the growths in the tubes.

Under the microscope the sponge-like tissue showed spaces with

projections of the character of villi. Groups of cylindrical epithelial processes were detected in the connective tissue matrix. These processes acquired a lumen, which grew larger till the cystic appearance was developed. Mr. Shattock has minutely described these characters elsewhere. It is clear that the tubal growths and the secondary deposits on the ovarian cyst were carcinomatous.

Warnek, a Russian authority, describes No. 12, the details of which are sufficiently explained in the tables. The pedicles of both diseased tubes were twisted. The malignancy of the growths was determined by Dr. Nikiforoff, Professor of Pathological Anatomy in the University of Moscow. Two features of particular interest are to be noted in No. 12. There was a tubo-ovarian cyst on the right side. The papilloma-

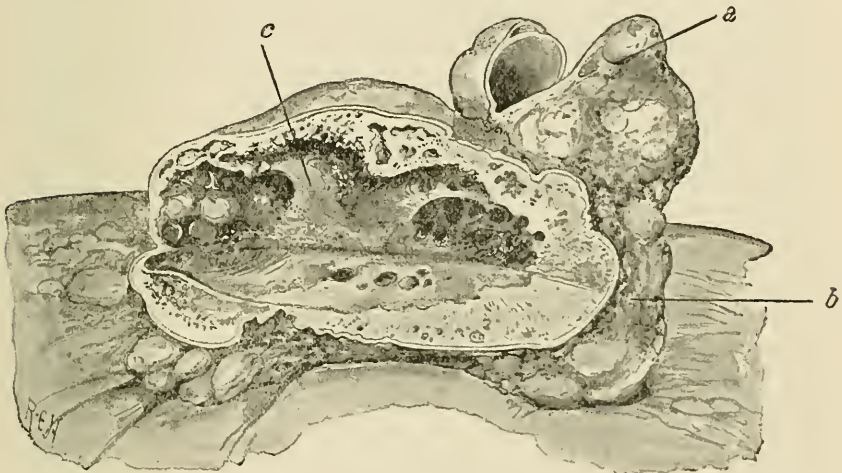

FIG. 210. — Dr. Cullingworth's case of primary cancer of the tube. It is seen lying on the surface of the cystic ovary. For lettering see text.

tous masses in the left tube were pedunculated. These facts associate the case with No. 3 in the papilloma series, where tubo-ovarian cyst was in course of development; though the cavities of the tube and ovary, both cystic, did not as yet communicate. In that case some of the papillomas were pedunculated. In other words, No. 3 Papilloma Tables seems to represent an early stage of the condition seen in Warnek's case.

No. 13 will shortly be reported in full; it is said to be a genuine example of primary cancer. No. 14 is a case where tubo-ovarian cyst seems to have existed. The right tube was dilated, and opened into a large cyst which contained over 17 pints of dirty brown fluid with sloughy shreds. This cyst, let it be remembered, could not be completely removed, and the limits of tube and ovary do not seem certain. It may be homologous to Warnek's case (No. 12), and thus represent a malignant degeneration of the condition seen in No. 3 Papilloma Tables.



On the other hand, the cyst into which the tube opened may have been independent of the ovary, as in Essex Wynter's case which will be described under a special heading.

No. 15, which is published in full in Péan's work, issued in the summer of 1895, bears a certain resemblance to No. 2. There was sanious discharge for some time. A special feature was the disappearance and reappearance of the hypogastric tumour. "Hydrosalpinx profluens" was diagnosed. The case, in fact, seems a malignant form of No. 5 (Doléris) in the Papilloma Tables. M. Péan is, I find, very sceptical about the primary character of tubal cancer. I have already shown, however, how that the tube is subject to papilloma, and how the papilloma may become cancerous,—facts favouring the probability of primary cancer of the tube. Moreover, Péan seems to believe in case 15, where there was clearly a true cancerous degeneration of tubal papilloma.

A few more cases of primary cancer of the normal Fallopian tube have been reported, but less fully than those already described. Dr. Smyly, of Dublin, relates that "I operated upon one case of cancer of the tube, supposing it to be an inflammatory condition. The operation was exceedingly difficult, and the rectum was opened in two places. These I closed by suture; but the patient died of collapse. The true nature of the case was revealed by the microscope." Dr. Smyly informs me that, unfortunately, the report of the case has been lost. At the time of the operation he had no idea that he "was dealing with a case of malignant disease. The tissue was very friable, though not more than in many inflammatory cases. The uterus appeared normal and the tube and ovary on the opposite side were free from disease. The specimen was examined by Dr. Earl, a very competent pathologist and assistant to the Professor of Physiology in Dublin University. He reported it as undoubtedly cancer. Had I suspected this I should certainly have examined the uterus, but, unfortunately, the woman was buried before I received his report. There was no cancer anywhere else so far as I could see at the operation."

Professor Zweifel recorded a second case of primary cancer of the tube in 1894. As in Dr. Cullingworth's case, it was associated with an ovarian cyst; and the diseased part corresponded in naked-eye appearances with the cancerous tube in case 6. Dr. Westermarck sent me the following important piece of information in January 1895: "I promised, in my paper, a future description of a new case of cancer of the tube, but at the last research this case showed itself to be a caneroid developed in the ovary (probably arising from a dermoid), which had grown into the tube. In July last I operated on another case of primary cancer of the tube, but as the pathological research is not finished, I am unable at present to give any further description." Säger, in his tables, adds the name of Mischnoff, but all that is said of the case is, "Not certain."

2. *Primary Cancer partly in a Cyst connected with the Ostium.*—A second form of primary cancer of the tube has been noted by two observers, and



I have been kindly permitted to examine the first case. The pathology of this form is somewhat obscure. The tube is malformed, its ostium opening into a distinct cyst.<sup>1</sup> This cyst is unconnected with the ovary. Zedel has already described and figured the anomaly in tubes where there was no suspicion of cancer.

Essex Wynter and Routier have reported these remarkable, though somewhat obscure cases. I am much indebted to Dr. Wynter and Dr. Voelcker for assistance in a thorough investigation of the case, which is briefly reported as a "Card Specimen" in the transactions of the Pathological Society.

The principal features are recorded in the tables (No. 16). The patient had menstruated regularly since the age of sixteen, she was well-nourished, but complained of loss of strength, having been stout. The nature of the disease was doubtful during life; her memory had failed considerably. Three days before her death pain began in the hypogastric region, and there had been vomiting in the morning. She became delirious, without fever, and died in the Middlesex Hospital about one month after admission.

There were caseous, tubercular deposits at the apices of both lungs. The liver was small and fatty; the kidneys fibrocystic. Other organs were normal, and there was no new growth in them or in the lymphatic glands. There was no ascites, and with the exception of a few intestinal adhesions to the tumour, the abdominal viscera were healthy. A cyst of the size of an ostrich's egg was attached to the right tube, with which it was continuous. This cyst contained 8 oz. of brownish fluid. It had ruptured and leaked; but, in Dr. Wynter's opinion, not till after death. There was no sign of peritonitis.

Such is the report. The exact cause of death remains obscure. The absence of any new growth beyond the limits of the tube and its abnormal cystic appendage remains certain.

I examined the specimen myself in October 1894. The appearances are indicated in Fig. 211.

The right tube measured 4 inches in length. The corresponding ovary (Fig. 211, *d*),  $1\frac{1}{2}$  inches in its longest measurement, was atrophied, elongated, and very thin. The ovarian ligament was abnormally long. The outer end of the ovary tailed off on to the surface of the cyst, from which that organ was otherwise quite distinct.

The first inch of the right tube was relatively narrow, and united to the elongated ovarian ligament by membranous perimetritic bands. The second inch and a half was dilated and very tortuous, and over an inch in diameter in its widest part. The remaining and outermost part of the tube was yet more dilated, forming a spherical cyst over an inch in diameter; in its wall was a solid deposit over a quarter of an inch in thickness (*a*). This outer portion communicated by an opening (*b*) with

<sup>1</sup> Dr. Martin's case, No. 1, may be of this kind; the ostium of the cancerous right tube opened into a cavity full of pus. As, however, there was suppuration of the left tube and ovary, the cavity most likely represented an abscess.

a thin-walled cyst (*c*). This cyst was quite free from the bladder, and measured six inches in diameter, before removal at the necropsy; the anterior part had burrowed under and lifted up the anterior fold of the corresponding broad ligament, raising the serous coat of the uterus and the innermost part of the anterior fold of the left broad ligament. These relations are not indicated in Fig. 211, which was taken after the peritoneum had been displaced during dissection. The interior of the cyst contained, in parts, a thick deposit which appeared encephaloid in character.

The left appendages were free from the cyst. The tube (*e*) was four

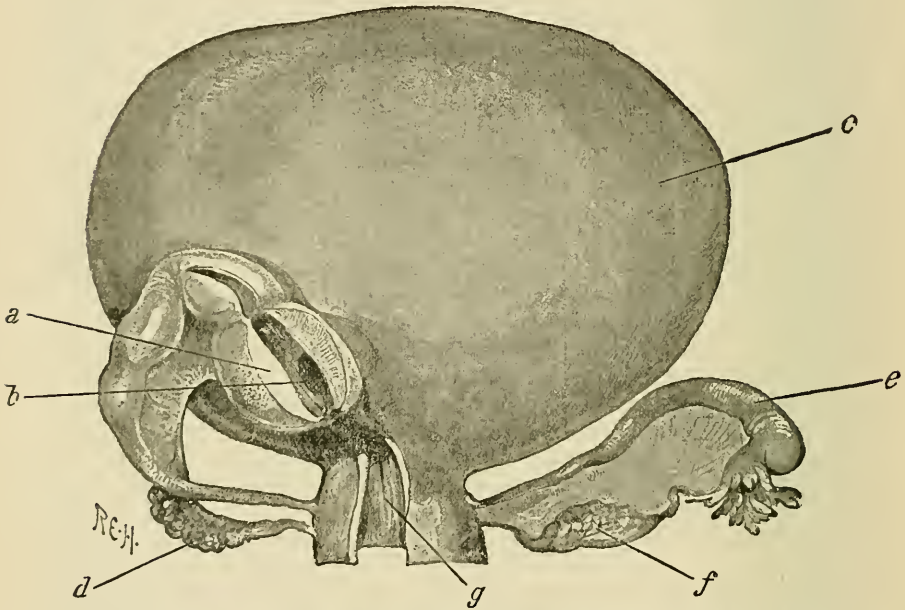

FIG. 211. — Dr. Essex Wynter's case of cancer of the tube. The uterine cavity (*g*) has been laid open. The uterus was closely adherent to the cyst (*e*), but did not communicate with its cavity. The rent in the right mesosalpinx was made after death. The view is anterior.

inches long, the infundibulum somewhat dilated, the ostium open. The left ovary (*f*), hardly an inch long, was atrophied; the ovarian ligament, very thick, measured an inch and a half.

I examined with Dr. Voelcker some microscopical sections taken from the deposit in the dilated extremity of the right tube. The stroma was scanty and formed wide alveoli containing cubical epithelium. In parts these cells were collected in great masses, as in encephaloid cancer.

All evidence seems to indicate that the tube was the primary seat of cancer, the disease extending to the abnormal cyst connected with the ostium. No. 17, M. Routier's case, resembled Wynter's in many respects. On the high authority of Professor Cornil, the growth was

pronounced to be "primary epithelioma of the tube." Cornil further considered that the cyst was connected with the tube, and was not ovarian; we must not forget, however, that the corresponding ovary could not be found at the operation. Hence the cancer may have developed in a true tubo-ovarian cyst. Eighteen months before the operation sharp pain was felt in the left iliac region, suddenly "an enormous quantity of lemon-coloured fluid" escaped from the vagina. The pain lessened and the tumour became at once much smaller. This escape of fluid reminds us of case 5 in the papilloma series, and case 15 in the Tables of Cancer. The etiology is quite different, but the pathology may be similar, the discharge coming from papillomas which ultimately became cancerous.

*General Considerations on Cancer of the Tube.* — The above records amply prove that cancer of the tube is not an unknown disease, and that it may certainly be primary. No doubt some of the reporters of the sixteen cases which are included in the Cancer Tables may have been mistaken. A primary seat of malignant disease, more or less distant from the tube, may have been overlooked. The tumour may in one or more cases have been sarcomatous, not cancerous. In one or more cases an innocent papilloma may have been recorded as malignant. Nevertheless the majority of the cases were cancerous. The cancer in nearly every tube assumed a villous or papillomatous appearance; the exceptions are doubtful, as the disease may have lost a papillomatous character which it originally possessed. The origin of papilloma may usually be traced to inflammatory changes. Hence cancer is a remote result of salpingitis; or perhaps it is safer to say, cancer is specially apt to attack tubes long subject to inflammation.

Clinically, at least, the early history of tubal cancer nearly always suggests tubal inflammation. The disease is unknown in youth. Out of the seventeen cases in the Cancer Tables only one was in a patient so young as thirty-six; and in this instance (No. 4) the after history indicated a very low degree of malignancy. Another patient was forty-three. All the remaining fifteen patients had passed their forty-fifth year.

When a patient who has reached her forty-fifth year, and has been subject to pelvic inflammation, shows a sudden or steady aggravation of subjective and objective symptoms, cancer may be suspected. A watery or especially a sanious discharge in such a case greatly increases the probability of malignancy.

*Treatment.* — If, as has been shown, removal of the tube is necessary in papilloma, it is all the more urgent in cancer. Out of the seventeen cases in the tables, sixteen underwent operation; two died of the direct effects of the operation; five lived over one year; four died within a year; whilst in five the after history is incomplete — one (No. 14) being convalescent when reported; one (No. 13) died of "marasmus" at an uncertain date; one (No. 15) was in good health eight months later, but the tumour had recurred; one (No. 8) was still alive and well seven months after operation, whilst the fifth (No. 17) never reported herself after convalescence.

For cancer the above record is by no means gloomy. Even when recurrence was comparatively rapid the patients seem to have enjoyed a few months of comfort. This was certainly the case in No. 2, which was under my own observation.<sup>1</sup>

**Sarcoma of the Fallopian Tube.** — In primary sarcoma of the ovary, a well-recognised and not very rare disease, the tube is seldom implicated. I have examined enormous sarcomas of the ovary where the tube remained intact. On the other hand, in a few cases I have seen sarcomatous nodules scattered over the peritoneal covering of the tube. The new growth more frequently passes from the ovary to the omentum, and to the serous investment of the intestines, uterus, and abdominal walls.

Few can deny that in all or nearly all the cases of alleged primary cancer of the tube the new growths were carcinoma, at any rate, if not primary. Thoughtful observers have expressed doubts whether the recorded cases of primary sarcoma of the tube do not demand a different interpretation. The growths, they believe, are not evidently sarcoma or even true neoplasms. The close relations of papilloma of the tube to carcinoma, and the tendency of the former to degenerate into the latter, have already been noted. When the stroma of a papilloma becomes abundant it may possibly undergo sarcomatous degeneration. Some of the cases in the tables may represent this change, which is certainly rarer than cancerous degeneration.

Much confusion exists in relation to the first recorded case, as the name of the original observer is Dr. Senger, which is often misspelt "Sänger," whilst another case has been reported by Professor Sänger himself. In this case (No. 1, Sarcoma Tables) papillomatous masses, consisting of small-celled, round-celled sarcomatous tissue were found growing from the tubal mucous membrane, chiefly in two oval dilatations of the tube. In one of these dilatations there was a polypoid growth containing collections of tubules lined with cylindrical epithelium, and surrounded partly by true sarcomatous tissue, partly by new connective tissue rich in nuclei. Dr. Senger believes that these tubules were derived from the parovarium; an opinion in accordance with Von Recklinghausen's new hypothesis quoted above (p. 806). The tubules suggest the appearances which I detected in the tube from case 2, Cancer Tables — an instance of cancer, not sarcoma, whatever the tubules may have been. I find that Sänger and Barth are of the same opinion. Dr. Coe of New York gives a different interpretation to this morbid appearance. He believes that the whole growth was no neoplasm, but chronic inflammatory deposit. He has observed a similar condition in many tubes removed for chronic inflammatory disease. The tubules were, he considers, simply gland-like depressions in the mucous membrane developed by the folding-in of the hypertrophied mucosa. I noted this condition in my description of No. 2 (Cancer Tables), but observed that it was also seen in papilloma. The history of the case may seem to favour Dr. Coe's view that the tube was

<sup>1</sup> I add in the Cancer Tables two cases (15a and 17a) of considerable interest, published since the above lines were written.



the seat, not of a tumour, but of old and quiescent inflammatory disease. Dr. Coe, however, must not overlook the fact that a similar history is the rule in cases of tubal cancer. The presence of a secondary deposit in Douglas' pouch makes me incline rather to the theory that the morbid deposits were new growths. Sanger (who also dwells on the secondary deposit) considers that Senger's case pathologically resembled his own (No. 4, Sarcoma Tables).

In case 2 there was a blood-cyst as big as an apple "between the sacrum and right ovary, adjacent to a tumour of the size of a walnut" developed in the abdominal portion of the right tube, the lumen of which was pervious. This tumour, on the high authority of Professor Landau, was a small-celled, spindle-celled sarcoma. No relation between the blood-cyst and the sarcoma is suggested,<sup>1</sup> nor any reference made to tubal pregnancy; the latter subject will be discussed in respect to Dr. Charles Dixon-Jones' cases.

Case 3 must remain doubtful. Dr. Janvrin's original report is excellent. Unfortunately, as in case 2, the patient died a few days after the operation, so that we cannot tell whether recurrence could have occurred had either patient recovered. The pathologist, Dr. Porter, does not speak very decidedly about Janvrin's tumour. "The general histological construction of this newly developed tissue would argue against its being classed as an inflammatory growth, but would place it among the mixed connective-tissue growths. Owing to the large variety of histological elements found, it is impossible to give it any single name which will in any adequate manner express the condition. It may well be classed under one of two headings, either as a composite fibro-sarcoma, or a composite myxo-sarcoma, the latter being the more accurate of the two." The photogravure appended to Janvrin's paper and the clinical report alike suggest that the tube was the seat of chronic inflammatory changes. Such changes, on the other hand, are sometimes followed by malignant tubal disease, as I have already shown.

The fourth case, Dr. Sanger's, is the least doubtful, for the patient recovered from the operation; but the mischief recurred and proved fatal. The microscopical report comes from a very trustworthy quarter. Professor Sanger calls the tumour "essentially a small-celled, round-celled sarcoma." There was a broad ligament cyst on the left side.

A remarkable paper was recently written by Dr. Charles Dixon-Jones, who quotes freely from Dr. Janvrin's report of case 3, accepting, it is clear, the opinion that it was an instance of sarcoma and not inflammation. Dixon-Jones received from Professor Formad of Philadelphia, thirty-five specimens of tubal tumours all believed to be cases of tubal pregnancy removed after death from women who had died suddenly. They were selected specimens from the necropsies of over 3000 adult women. Many of the thirty-five were decomposed. Of those found fit for microscopic section three proved, in Dixon-Jones' opinion, to be

<sup>1</sup> Both tumours might have been sarcoma originally. See Godlee, "Blood-cyst developed in a Sarcoma." *Trans. Path. Soc.* vol. xxvi. p. 193.

malignant tumours of the tube-wall, and not tubal pregnancies. Intra-peritoneal hæmorrhage is assumed as the cause of the sudden death in all the thirty-five cases. In the three supposed malignant cases there certainly was evidence of rupture of the tubal wall and hæmorrhagic infarction into the substance of the new growth. The large vessels involved in the sarcoma tissue seem to have yielded. Dixon-Jones describes the three specimens as (1) "globo-myeloma (large round-celled sarcoma)"; (2) "spindle myeloma (large spindle-celled sarcoma of Virchow)"; (3) "melanotic myeloma (melanotic sarcoma of Virchow)."

No pathologist could accept unconditionally the opinion that these morbid specimens were really sarcomas. The clinical histories are hypothetical. The alleged discovery, in so limited a number of specimens, of three cases of a rare disease, the very existence of which is still disputed, is in itself suspicious. Where else do we hear of a case of sudden death from rupture of a sarcomatous tube? Old inflammatory deposits mixed with blood-clot and relics of tubal gestation may readily deceive the pathologist.

Finally, it is clear that primary sarcoma of the tube as a disease is very rare, and as a subject highly obscure. The evidence of Sænger and Landau establishes the fact that a tumour of this pathological class may involve the mucous membrane. Sænger's case seems to support this evidence. Janvrin's shows that sarcoma may be confined, or almost confined, to the deeper part of the tubal wall. Sænger seems inclined on that account to place that case (No. 3) in a distinct sub-class. We have not sufficient evidence, however, to prove that sarcoma does not always arise in the interior of the tubal wall, as the pathologist would naturally expect. In 2 and 4, where the mucosa was involved, the disease was advanced. The difficulty of distinguishing between new growths and inflammatory deposit greatly complicates the sarcoma question on account of the well-established frequency of true inflammatory changes preceding the development of a true neoplasm. Nothing can be decided until more clinical evidence is at our disposal. In the meantime there can be no doubt that the timely removal of a suspected sarcoma of the tube is justifiable.

**Deciduoma Malignum of the Tube.**—Two cases of this remarkable disease have been described, both, in Professor Sænger's opinion, seeming quite authentic. Deciduoma malignum, or malignant degeneration of relics of the fetal envelopes and appendages, is a disease which has been repeatedly noted during the past ten years on the Continent. The very existence of this disease, as distinct from ordinary sarcoma following pregnancy, has recently been disputed in this country (50*a*). If malignant degeneration of a piece of placenta or chorion can really produce a large uterine tumour followed by metastatic deposits in the abdominal and thoracic viscera, it is not surprising that a similar malignant change may occur in a tubal sac in ectopic pregnancy.

Sænger holds that the possibility of deciduoma malignum following tubal pregnancy being established, we have one more argument not only

for active interference in cases of abnormal gestation, but also for the extirpation of tubal moles and appendages where "tubal abortion" has occurred. I leave the question to the consideration of obstetricians; the subject of tubal gestation is treated in another section of this work. I felt, however, that deciduoma malignum must be mentioned under the head of malignant new growths affecting the tube.

Finally, I say "malignant," not "cancerous," or "sarcomatous," because the few authorities who have observed deciduoma are not quite agreed as to the precise nature of its malignancy.

ALBAN DORAN.

#### REFERENCES

1. BALLANTYNE and WILLIAMS. "The Histology and Pathology of the Fallopian Tubes," *Brit. Med. Journal*, vol. i. pp. 107, 168.—2. BANDL. "Die Krankheiten der Tuben, der Ligamente," etc., Billroth und Lücke, *Deutsche Chirurgie*, 1886.—3. BARTH, see SÄNGER.—4. CART. "De l'actinomycose," *Archives générales de médecine*, vol. clxxiii. 1894, p. 342.—5. CHAFFEY, W. C. "Pyosalpinx in a Child," *Trans. Path. Soc.* vol. xxxvi. 1885, p. 303.—6. CHIARI. "Zur pathologischen anatomie des Eileiterkatarrhs," *Prager Zeitschrift für Heilkunde*, vol. viii.—7. CHOUX. "Étude clinique et thérapeutique de l'actinomycose," *Archives générales de médecine*, vol. i. 1895, p. 664.—8. CHROBAK. Knauer "Ein Fall von primären Carcinom der Tube bei einer Tubo-ovarial Cyste," *Centralblatt f. Gynäk.* 1895, p. 574.—9. COE. "Neoplasms of the Tubes," *Mann's American System of Gynec.* vol. ii. p. 895.—9a. CULLEN, T. S. "Tuberculosis of the Endometrium," *Johns Hopkins Hosp. Rep.* vol. iv. pp. 367, 441.—10. CULLINGWORTH. (a) "The Value of Abdominal Inosp. in certain Cases of Pelvic Peritonitis," *Trans. Obst. Soc.* vol. xxxiv. 1892. (b) "Primary Carcinoma of the Fallopian Tube," *Trans. Obst. Soc.* vol. xxxvi. 1894, p. 307.—11. DEMONS. "Épanchemens pleurétiques compliquant les kystes de l'ovaire," *Bulletins et mémoires de la Société de Chirurg. de Paris*, vol. xiii. 1887, p. 771.—12. DIXON-JONES, CHARLES. "Three Cases of Myeloma (Sarcoma) of the Fallopian Tube," *American Journal of Obstetrics*, vol. xxviii. 1893, p. 324.—13. DIXON-JONES, MARY. "The Minute Anatomy of the Fallopian Tubes," *American Journal of Obstetrics*, vol. xxix. 1894, p. 785.—14. DOLÉRIIS. "Tumeur végétante de la muqueuse tubaire; Papillome endo-salpingitique; Échec du traitement intra-utérin; Ablation par laparotomie," *Bulletins et mémoires de la Société Obst. et Gynéc. de Paris, pour l'année 1890*.—15. DORAN. (a) "Papilloma of the Fallopian Tube, associated with Ascites and Pleuritic Effusion," *Trans. Path. Soc.* vol. xxxi. 1880, p. 174; (b) *Ibid.* vol. xxxviii. p. 241; (c) "Papilloma of both Fallopian Tubes and Ovaries," *Ibid.* vol. xxxix. p. 201; (d) "Primary Cancer of the Fallopian Tube," *Ibid.* same volume, p. 208 and vol. xi. (sequel to same case) p. 221; (e) *Ibid.* vol. xli. 1890, p. 202; (f) "Papilloma of the Fallopian Tube and the Relation of Hydroperitonium to Tubal Disease," *Trans. Obst. Soc.* vol. xxviii. p. 229; (g) *Ibid.* vol. xxix. 1887, p. 186; (h) "Cases of Tuberculous Disease of the Uterine Appendages and Peritonium," *Brit. Med. Journal*, vol. ii. 1893, p. 887; (i) Figured in a woodcut illustrating "Two Cases of Ovariectomy performed twice on the same Patient," *Lancet*, vol. ii. 1894, p. 1415.—16. EBERTH and KALTENBACH. "Zur Pathologie der Tuben," *Zeitschrift f. Geburtshülfe und Gynäk.* 1889, p. 357.—17. EVE, F. S. See LAWSON TAIT. "An undescribed Disease of the Fallopian Tubes," *Trans. Obst. Soc.* vol. xxv. 1883, p. 249.—17a. F. FABRICIUS. *Archiv f. Gynäk.* vol. i. 1896, p. 385.—18. FEARN. Leopold's *Arbeiten aus der Königlich. Frauenklinik.* Dresden, vol. ii. p. 337.—19. FROMMEL. "Beiträge zur Histologie des Eileiters," *Verhandlungen der Deutsch. Gesellschaft f. Gynäk.* 1885, p. 95.—19a. GODART. *Annales de l'Institut St. Anne*, Brussels, No. 4, March 1896.—20. GOTTSCHALK. "Primäres Tubensarcom," *Centralbl. f. Gynäk.* 1886, p. 727.—21. GRIFFITH, WALTER S. A. "Tubercle of the Ovaries," *Trans. Path. Soc.* vol. xl. 1889, p. 212.—22. HARTMANN. "Pyosalpingites gonococcienens sans oblitération du pavillon de la trompe," *Annales de Gynéc. et d'Obstét.* vol. xliii. 1895, p. 333.—23. HENNIG. *Die Krankheiten der Eileiter und die Tubenschwangerschaft*, 1876.—24. ILLICH. *Beitrag zur Klinik der Actinomycosen*, 1892, pp. 102-7 and 138.—25. JANI. "Ueber das Vorkommen von Tuberkelbacillen in



gesunden Genitalapparat bei Lungenschwindsucht," *Virchow's Archiv*, vol. ciii. p. 522.—26. JANVEIN. "A Case of Myxo-Sarcoma of Fallopian Tube," *Annals of Gynæcology*, vol. ii. p. 357. Boston, U. S. A.—27. KEATING and COE. *Clinical Gynæcology, Medical and Surgical, by American Teachers*, 1895.—28. KOSSMANN. "Zur Pathologie der Urimierenresté des Weibes," *Monatsschrift f. Geburtsch. und Gynäk.* vol. i. 1895, p. 97.—29. LANDAU and RHEINSTEIN. "Beiträge zur pathologischen Anatomie der Tube," *Archiv f. Gynäk. und Geburtsh.* vol. xxxix. p. 272.—29a. *Ibid. Loc. cit.* p. 273.—30. MARTIN. *Die Krankheiten der Eileiter*, 1895.—31. MENGE. "Ueber tuberkulöse Pyosalpinx," *Centrabl. f. Gynäk.* 1894, p. 24.—32. MÜNSTER and ORTMANN. "Ein Fall von Pyosalpinx auf Tuberkulöser Grundlage," *Arch. f. Gynäk.* p. 97.—33. OTT. *Beiträge zur Kenntniss der ektopischen Formen der Schwangerschaft*. Leipzig, 1895. (For the case here quoted see p. 34, and Fig. 7 in Dr. Von Ott's work.)—34. ORTHMANN. "Ueber Carcinoma Tubæ," *Zeitschrift f. Geburtshülfe und Gynäk.* vol. xv. p. 212.—35. PARONA. "Caso di Lipoma all ovaia ed ovidotto di destra," *Annali di Ostetricia e Ginecologia*, 1891, p. 103.—36. PÉAN. *Diagnostic et traitement des tumeurs de l'abdomen et du bassin*, vol. iii. "Tumeurs primitives des Trompes," pp. 547 to 571.—37. PENROSE and BEYEA. "Tuberculosis of the Fallopian Tubes," *Amer. Jour. Med. Sciences*, vol. cviii. 1894, p. 520.—37a. RECKLINGHAUSEN. *Die Adenomyome und Cystadenome der Uterus- und Tubenwandung*, 1896.—38. REYMOND. *Contribution à l'étude de la Bactériologie et de l'Anatomie Pathologique des Salpingo-Ovarites*, 1895.—39. RITCHIE. "Dermoid Cyst developed in the Fallopian Tube," *Trans. Obstet. Soc.* vol. vii. p. 854.—40. ROUTIER. "Épithélioma primitif de la Trompe," *Annales de Gynéc. et d'Obstét.* vol. xxxix. 1893, p. 39.—41. SÄNGER, Professor M. "Etiology, Pathology, and Classification of Salpingitis," *Amer. Journ. Obstet.* vol. xx. 1887 ("Actinomycesis," p. 320); also chapter on New Growths in Martin's *Die Krankheiten der Eileiter*.—42. SCANZONI. *Lehrbuch der Krankheiten der weiblichen Sexual-organe*, 5th ed. 1875, p. 511.—43. SCHRAMM. "Zur Kenntniss der Eileitertuberkulose," *Archiv f. Gynäk.* vol. xix.—44. SCHWARTZ. "Fibromyome de la Trompe Utérine droite à son origine; Métrorrhagies et accidents nerveux; Laparatomie; Ablation; Réduction du pédicule; Guérison," *Bulletins et mémoires de la Société Obstétrique de Paris*, 1890, pp. 73-76.—45. SCHROEDER. *Die Krankheiten der weiblichen Geschlechts-organe*, 7th ed. 1883, p. 361.—46. SENGER, EMIL. "Ueber ein primäres Sarkom der Tuben," *Centrabl. f. Gynäk.* 1886, p. 601.—47. SILCOCK, A. QUARRY. "Tubercular Endometritis and Salpingitis, associated with Accumulation of Tubercular Matter in the Body of the Uterus and Fallopian Tubes of a young Child," *Trans. Path. Soc.* vol. xxxvi. 1885, p. 303.—48. SIMPSON, Sir J. Y. *Clinical Lectures on the Diseases of Women*, 1872. Fig. 93, p. 540.—49. SMYLY. "Report of 112 Abdominal Sections performed in the Rotunda Hospital," *Dublin Journ. of Med. Science*, vol. xcv. 1893, p. 285.—50. SPAETH. "Ein Fall von Fibroid des Eileiters," *Zeitschrift f. Geburts. und Gynäk.* vol. xxi. p. 363, and plate x.—50a. SPENCER, HERBERT, and others. *Trans. Obstet. Soc.* vol. xxxviii. 1896, Part 2.—51. STEWART, Sir T. GRAINGER. "Note on a Case of Actinomycesis of Ovaries and Liver," *Edin. Hosp. Rep.* vol. i. 1893, p. 96.—52. SUTTON, J. BLAND. *Surgical Diseases of the Ovaries and Fallopian Tubes, passim*.—53. TREUB. *Leerboek der Gynaecologie*, 1895, p. 470.—54. VEIT. Report of a Meeting of the Berlin Obstetrical and Gynaec. Soc., *Zeitschr. f. Geburts. und Gynäk.* vol. xvi. 1889, p. 212.—55. WARNEK. "Trois cas des tumeurs des Trompes compliquées de la torsion du pédicule," *Nouvelles archives d'Obstét. et de Gynéc.* 1895, p. 81.—56. WEICHELBAUM. *Elements of Pathological Histology*. Translated by Dr. Dawson, 1875, p. 318.—57. WESTERMARK and QUENSEL. "Ett Fall af dubbelsidig kancer i Tubæ Fallopii," *Nordiskt. Mediciniskt Arkiv*, vol. xxiv. 1892.—58. WILLIAMS, Sir JOHN. *On Cancer of the Uterus*, being the Harveian Lectures for 1886, plate xvi.—59. WILLIAMS, J. WHITRIDGE. (a) "Contributions to the Normal and Pathological Histology of the Fallopian Tubes," *Amer. Journ. Med. Sciences*, vol. cii. 1891, p. 377; (b) "Tuberculosis of the Female Generative Organs," *Johns Hopkins Hosp. Rep.* vol. iii. 1892.—60. WYNTER, W. ESSEX. "Primary Carcinoma of the Right Fallopian Tube, with large Cyst in connection with the New Growth," *Trans. Path. Soc.* vol. xlii. p. 221.—61. ZEMANN. *Medicin. Jahrbuch des K. K. Gesellschaft d. Aerzte in Wien*, 1883.—62. ZWEIFEL. *Verlesungen über klinische Gynäkologie*. Berlin, 1892, pp. 139-142.



PAPILLOMA OF THE FALLOPIAN TUBE. (This Table only includes cases closely observed clinically and pathologically.)

No.	Age and Condition.	Side.	Chief Symptoms.	Duration of Symptoms before Operation.	Character of Tumour.	Result of Operation.	Operator.	Reference.
1	50 S.	R.	Acute pelvic inflammation. No vaginal discharge. Effusions into pleura and peritoneum	2 years	Tube dilated, filled with papillomatous growths, none on its exterior or elsewhere. Ostium patentous, allowing escape of secretion into peritoneum. Uterine end open	Recovery, well 16 years afterwards	Spencer Wells	Doran, <i>Trans. Path. Soc.</i> vol. xxxi, 1880, p. 174; <i>Trans. Obst. Soc.</i> vol. xxviii, 1886, p. 236; and Bickersteth, private correspondence
2	45 M.	R.	Amenorrhoea, pelvic pain, tense tumour. Difficulty in micturition and defecation. No ascites, no vaginal discharge	1 year	Tube dilated, filled with papillomatous growths. Ostium closed, state of uterine end uncertain. Bilobular cystic cavity of uncertain nature below tube	Died 4th day	Bantock	Doran, <i>Trans. Obst. Soc. loc. cit.</i> p. 230
3	31 M.	R. and L.	Pelvic inflammations and swellings, both symptoms fluctuating. No ascites, no vaginal discharge	7 years	Tube dilated, filled with papillomatous growths. Ostium closed. Ovary cystic, containing papillary growths. No communication between tube and ovary on either side. No growths outside cysts	Recovery, alive 8 years later	Bantock	Doran, <i>Trans. Path. Soc.</i> vol. xxxix, 1888, p. 200
4	(?)	(?)	Ascites	(?)	Papillomatous growths in outer third of tube issuing out of ostium, which was patulous	Died	Waller, Manchester	Sutton, <i>Surgical Diseases of the Ovaries and Fallopian Tubes</i> , p. 226, 2nd edition, and Dr. Waller, private correspondence
5	28 S.	R.	Vaginal discharge, probably gonorrhoea, at 21; 4 years hy-postric pains; 15 months profuse serous discharge from vagina. No ascites	7 years	Papillomatous growths in right tube, none outside. Ostium closed, uterine end dilated. Chronic inflammatory disease of opposite appendages	Recovery, alive over 4 years afterwards	Doleris	Doleris, <i>Bulletin et mémoires de la Société Obstet. et Gynéc. de Paris</i> , 1890, p. 12, and private correspondence
6	39 (?)	R.	Severe pelvic pains and profuse menstruation; menorrhagia. Large bulbous swelling on each side of uterus. No ascites, no vaginal discharge	(?)	Right tube size of a finger. "Interior stuffed with adenomatous masses" resembling those in No. 1. Ostium open. Left tube diseased. (See text)	Recovery, alive nearly 4 years after operation	Bland Sutton	Sutton, 1st edition, p. 285, see No. 4; also private correspondence (not recorded in 2nd edition)

For Godart of Brussels' case see text.

CASES OF PRIMARY MALIGNANT DISEASE OF THE FALLOPIAN TUBE.

I. — CARCINOMA.

A. — Cancer in a Normally-developed Tube.

No.	Age, Married or Single.	Children, Date of Menopause.	Side of Tumour.	Chief Symptoms.	Duration of Symptoms before Operation.	Result of Operation.	Character of Tumour.	Other Parts Involved.	Operator.	Reporter and Reference.
1	46 M. (8 yrs. only)	Abort. (3) 1½ yrs. before operation	R.	After convalescence from typhoid fever, tumour to the right of uterus, then moderate leucorrhœa. Encysted serous perimetritis to left.	About 1½ years	D. 6th day	Cancerous papillomatous growths in the abdominal end of the tube. Ostitum communicated with a pus-cavity	Cancerous nodules in vesico-uterine pouch. Enlarged pelvic glands. Large abscess of right ovary. Suppuration of left tube and ovary	Martin, Berlin	Orthmann, "Ueber Carcinoma Tubæ," <i>Zeitsch. f. Geburtshülfe</i> , vol. xv. 1888, p. 212
2	45 M.	1 child, 22 years 6 months	R.	Sanious, watery discharge; perimetritis after scraping of endometrium; then tumour to right of uterus	3 years	Lived 10 months 3 weeks	Large, soft, cancerous mass growing from tubal walls. Fetid bloody serum in tubal canal	Right ovary small, cancerous. Left appendages much diseased through old inflammation. Recurrence in stump of left appendages. Secondary deposits in uterus, bladder, vagina, and lumbar glands	Thornton	Doran, <i>Trans. Path. Soc.</i> , vol. xxxix, p. 208, and vol. xl. p. 221
3	50 M.	Sterile, 6 months	R. and L.	Sanious, watery discharge, club-shaped swelling in right fornix, and pains 8 weeks before operation. Elastic tumour as big as a plum in left fornix; small subperitoneal uterine myoma	4 years	"Recurrence within 18 months" (von Herr, Dec. 1894); see text	Medullary masses in both tubes; possibly innocent papilloma at the date of operation; see text	Apparently (at operation) no extension to neighbouring organs. Recurrence on both sides, chiefly left	Kaltenbach	Kaltenbach, <i>Centralblatt f. Gynäk.</i> , 1889, p. 74. Id. and Eichert, <i>Zeitsch. f. Geburtsh. u. Gynäk.</i> , vol. xvi. 1889, p. 357, and Prof. von Herr, private correspondence, Dec. 1894
4	36 M.	Sterile (?)	L.	Hypogastric pains, fever, swelling in left side of pelvis	"For a long time" (Veit)	"Free from recurrence and in good health" nearly 7 years afterwards (Veit, Jan. 1895)	A pyosalpinx with cancerous papillomatous masses on its inner wall	No other parts involved	J. Veit	J. Veit, <i>Zeitsch. f. Geburtsh. u. Gynäk.</i> , vol. xvi. 1889, p. 212, and private correspondence, Jan. 1894

5	6 M.	Sterile. Regular	R.	Uterus pushed to right by a left hydrosalpinx. A tumour on right side of pelvis. Hypogastric pain	2 years (pain)	Recovery; recurrence within 10 months. "The patient must have died soon afterwards"	Right tube contained a medullary mass; true medullary cancer, large alveoli, and scanty stroma	No other parts cancerous. Right ovary atrophied. A pint of sanious, watery fluid in left tube, which was not removed. Ten months later "abdomen and pelvis full of tumours of a hard, irregular form; a little ascites." Patient emaciated	Landau	T. Landau and Rheinstein, <i>Archiv f. Gynäk.</i> , vol. xxxix, 1891, p. 278, and private communication
6	46 M. 20 yrs.	1 child. Periods still regular	R. and L.	Free, watery discharge. Abdominal pain, emaciation. Two tumours felt through parietes	About 9 months	"Lived for about a year and a half." (Zweifel, December 1894)	Distended tubes full of large, soft villous masses. Microscopical characters of "carcinoma papillomatatum"	Uterus, ovaries, and adjacent parts healthy. (Uterus removed as a precautionary measure)	Zweifel	Zweifel, <i>Vorlesungen ueber Klin. Gynäk.</i> , 1892, p. 139; and private correspondence
7	45 S.	1 child. Period still regular	R. and L.	Hypogastric pains; metrorrhagia; elastic tumour of the size of a fist in right side of pelvis; smaller tumour to left and above uterus	1 year	Recovery; recurrence in 2 months; death in 5 months	Advanced papillomatous cancer of right tube, involving ovary. Cancer of left tube, not involving ovary. Cystic degeneration of ovaries and tubes	At necropsy cancerous deposits found in liver, uterine mucous membrane, and pelvic lymphatic glands	Westermarck	Westermarck and Quensel, <i>Vordiskt med. Arkiv</i> , vol. xxiv, 1892, pt. 7, No. 2. Also <i>Centralblatt f. Gynäk.</i> , 1893, p. p. 272 and 1197 (two reports by different writers). And private communication from Dr. Westermarck
8	45	1 child 20 years ago. Still regular, scanty show	R.	Symptoms of "painspangitis." Menorrhagia. Uterus dilated shortly before operation; nothing found in it	"Some time later"	Recovery; no recurrence 7 months later	Papillomatous cancerous mass in outer part of tube; the inner and a half next the uterus was free from malignant disease	..	Sänger	Sänger, in Martin's <i>Krankheiten der Frauen</i> , p. 253
9	56 M.	Sterile. Regular	R.	Sanious, serous discharge; dysuria. Latterly a large tumour developed on right side, diagnosed as a "subperitoneal uterine myoma"	1½ years	Recovery; "patient alive and free from recurrence 1 year and 7 months after operation"	Large sausage-shaped tumour 7 inches long. Exuberant papillomatous masses on inner walls ("Carcinoma papillare," or "Carcinoma adeno-papillomatousum")	No other parts were found involved. Ovary atrophied, no trace of cancer in its substance	Leopold	Fearn, <i>Arbeiten aus der Königl. Frauenklinik</i> , Bresden, vol. li, p. 381, and private correspondence with Professor Leopold

1 (2) signifies no note about menopause or catamenia.

CASES OF PRIMARY MALIGNANT DISEASE OF THE FALLOPIAN TUBES — Continued.

No.	Age, Married or Single.	Children, Date of Menopause.	Side of Tumour.	Chief Symptoms.	Duration of Symptoms before Operation.	Result of Operation.	Character of Tumour.	Other Parts Involved.	Operator.	Reference.
10	55 (?)	..	R.	Hypogastric pains; discharge of blood. Fluctuating tumour in right side of pelvis, right iliac fossa, and Douglas' pouch	2 months	Recovery; free from recurrence 1 year later. "Afterwards lost sight of"	Reduplicated villous mass growing from tubal wall; the mass was epitheliomatous. Much clot and serum in dilated canal of tube	No evidence of extension at operation. Uterus and opposite appendages normal. Circulation, respiration and digestion unaffected	Anger	Tuffier, <i>Annales de gynéc. et Obstet.</i> , vol. xlii, 1894, p. 203; and private correspondence
11	60	Sterile. 52	R.	Attacks of pain in right iliac fossa. Nodulated swelling in hypogastrium. No discharge	4 months	Recovery; recurrence in 6 months. Death 1 year after operation	Spongy mass of cancer inside tube, which was obstructed at abdominal end and connected with a cystic tumour of the ovary	"Evidence of infection beyond the limits of parts removable by operation." "Cancerous patches on surface of the ovarian cyst. No necropsy"	Cullingworth	Cullingworth and Shattock, <i>Trans. Obst. Soc.</i> , vol. xxxvi, 1894, p. 307; and private communications and personal inspection of specimens
12	43 S.	3 children. Catamenia 3-weekly. Menorrhagia	R. and L.	Pain after exertion 19 days before operation. Fever and dysuria. Torsion of an ovarian pedicle suspected. Small hypogastric tumour; cord-like body in right fornix, tender swelling in left	..	Death, 3 weeks after removal of tumours, from intestinal obstruction, and a few hours after an operation for relief of the obstruction	Papillomatous growths in both tubes, which were greatly enlarged ("papillary case found in abdominal cavity after death. See text	Ovaries and uterus free from cancer. No trace of malignant disease found in abdominal cavity after death	Warnek	Warnek, <i>Novel-les Arch. et de gynéc.</i> , 1895, p. 81
13	"In climacteric age"	..	R. and L.	Escape of pus. Tumour like a pyosalpinx to the right	..	Death from "Malignant rasmus"	Papillary cancer and suppuraton of both tubes	Inguinal and retroperitoneal glands	Von Rosthorn	Ditto. ("The case will be published in full")



14	58 M.	I.	18 years swelling of abdomen; recently great pain, ill-health, and increase in size of tumour	18 years	Incomplete. Con- valescent when re- port was published	A cancerous papillo- matous mass in the droopsical right tube, which communicated with a large ovarian (?) cyst <sup>1</sup>	No sign of cancer in uterus, other append- ages and peritoneum	Chrobak (Uterus and appendages re- moved. A piece of the ovarian tumour could not be re- moved, and was fixed to the uterine stump in the abdominal wound)	Knauer, <i>Central- f. Gynaik.</i> 1885, p. 574.
15	46 M.	R. and L.	2 months amen- orrhœa; then uter- ine hæmorrhage and hypogastric swelling, which dis- appeared after at- tack of colicky pain. Free "se- rous leucorrhœa." Mass filling both fornices and Dou- glas' pouch	8 months	Recovery 8 months after operation. A mass size of fist in pelvis	Papillomatous cancer of tubes, which were dilated and full of se- rosanguineous fluid. Chondrification of part of wall of left tube	No sign of cancer in adjacent organs at operation	Lebedeff	Miknoff, Péan. <i>Diagnostic et traite- ment des tu- meurs de l'abdo- men</i> , vol. iii. 1895, p. 564
16	59 S.	R.	Discharge of blood for a few months before ad- mission. Hypo- gastric pain for three days before death	"III" 4 months. See text	None	Mass of medullary cancer in ostium of tube; communication with a cyst external to tube and ovary	No extension to neighbouring or dis- tant parts	None	W. Essex Wyn- ter, <i>Trans. Path. Soc.</i> , vol. xli. p. 222, and text of present treatise
17	60 M.	L.	Abdominal swell- ing. Escape of quantities of yellow fluid from vagina, swelling diminish- ing. Phlebitis, left leg	2 years	Recovery from operation (Nov. 22, 1892). Case lost sight of	Cancerous papilloma in walls of tube, the ostium opening into a cyst of the size of an adult head. Ovary not found. See text	No other parts were involved	Routier	Routier, <i>Enlle- tins et mémoires de la société de chirurgie de Paris</i> , vol. xviii. 1892, p. 108, and <i>Annales de gynéc. et d'obstét.</i> vol. xxxix. 1893, p. 39, and private corre- spondence

### B. — Cancer partly in Cyst connected with Ostium.

<sup>1</sup> I suspect that Nos. 12 and 14, where tubo-ovarian cyst existed, represented a malignant degeneration of papilloma of the type seen in No. 3 in the "Papilloma" Table. Possibly, however, they were like 16 and 17 in this series.

(The following cases were published when the text was completed.)

CLASS A.

No.	Age, Married or Single.	Children. Date of Menopause.	Side of Tumour.	Chief Symptoms.	Duration of Symptoms before Operation.	Result of Operation.	Character of Tumour.	Other Parts Involved.	Operator.	Reference.
15 a	40 M.	1 abort. Recovered before illness	R. and L.	Yellow discharge 7 months, hypogastric pain. Period ceased 3 months, then came on again. Ovary tumour reached above umbilicus. Deposit in Douglas' pouch	Over 7 months	Recovery. Died 7 months after operation. No necropsy	Papillomatous cancer of tubes. The right tube formed a large cyst. Left tube could not be removed, it was united by malignant deposit to adjacent structures	Metastatic deposits on visceral peritoneum and omentum. A little ascites	Fischel	<i>Prager's Med. Wochenachricht.</i> J. Heilkunde, xvi, 1886, p. 143

CLASS B.

17 a	58	1 ch.	(?)	Hypogastric inflammation 30 years before. For 18 years a stationary swelling of abdomen. 1 year hypogastric pain, cystitis. Cyst filled abdomen at last	18 years tumour A cute symptoms 1 year	Well 3 months after operation	Tabo-ovarian cyst "with a primary cancer of the tube adjacent to it"	Firm adhesion of cyst to adjacent parts, part left behind	Savor	Savor "Cystitis evouosa bei saucem Haru," <i>Wiener klin. Wochenachricht.</i> , vol. viii, 1895, p. 775
------	----	-------	-----	---	--	-------------------------------	--	---	-------	---

II. — SARCOMA.

1	51 M.	(?)	R. and L.	No clinical symptoms of helvic disorder. Disease discovered after death of patient from diabetes	Unknown	No operation	Two oval dilatations in each tube, containing papillary masses made up of rounded sarcoma	Secondary deposit in Douglas' pouch	None	Senger, <i>Centralblatt f. Gynäk.</i> 1886, p. 601.
---	-------	-----	-----------	--	---------	--------------	---	-------------------------------------	------	---

2	37 M.	3 children. Regular	R.	Hypogastric pain; two tumours to right of uterus	3 months	Death, 4th day	Small-celled spindle- celled sarcoma in ab- dominal half of tube involving mucosa	Secondary deposit in Douglas' pouch; blood-cyst behind ova- ry (no necropsy)	Landau	Gottschalk, <i>Cen- tralblatt. Gynäk.</i> 1886, p. 727
3	36 M. 15 years	Sterile. Regular	R.	Pelvic peritonitis (second attack) present when opera- tion was perform- ed. First attack 12 years earlier	4 months	Death, 4th day	Myxo-sarcoma (?) in tubal wall, mucosa hardly involved. Tube over 4 inches long, quite firm and solid, containing no fluid	A abundant old adhe- sions; no new growth beyond tube	Janvrin	Janvrin, <i>Annals of Gynaecology</i> , vol. ii. 1889, p. 357
4	42 M. 18 years	Sterile. Menorrhagia	R. and L.	Injury from fall, 6 months; menor- rhagia; watery dis- charge between periods. Eimada- tion. Tumour fill- ing left side of ab- domen, extending to right side in- feriorly	6 months	Recovery. Re- currence. Lived over 7 months	Papillary masses of small round-celled sar- coma springing from mucosa of left tube, which was connected with a cyst in the broad ligament, holding three pints of a brown fluid. Eight tube formed a pyosalpinx with malig- nant contents	Recurrence in pelvis. Inguinal glands en- larged	Sänger	Sänger, <i>Marin's Vierteljahrsschrift der Ärzte</i> , p. 286

N.B. — For cases less completely reported (Renaud, Smyly, Zweifel, and Westermarck) see text.  
For C. Dixon Jones' cases see text.

ALBAN DORAN.

## DISEASES OF THE OVARY

TUMOURS OF THE OVARY. — Solid tumours of the ovary arise from the connective-tissue stroma; cystic tumours, on the other hand, although their walls and a large part of their solid contents have a similar origin, appear to arise either from Graafian follicles, or from ingrowths of the germ epithelium which covers the ovary.

I propose in this article to avoid, as far as possible, the minute subdivision of ovarian tumours which has been the first and the natural result of the labours of investigators in a new field; and also the somewhat speculative views of the origin of the different varieties. While, for the most part, the characteristic features of the principal classes are readily recognisable, the variations and combinations of them are so numerous that, in the present state of our knowledge, it is often not practicable to classify a particular tumour with certainty. Innocent kinds pass by almost insensible gradations into malignant; solid tumours develop cysts, and cystic tumours develop solid masses; papillomatous growths develop both in cystic tumours and on the surface of the ovary without any cystic formation; and cysts with papillomatous or dermoid contents occur either alone, or as parts of tumours of different kinds.

I propose, therefore, to describe first the characters common to all, and then to point out some of the features of special kinds.

The first requirement for a systematic investigation of ovarian tumours is undoubtedly a knowledge of the structure of the healthy ovary. The absence of this knowledge, and the inherent difficulties of the subject, have led and still lead to much difference of opinion on points which by this time should have been settled.

The bulk of the solid parts of all ovarian tumours is composed of well-developed connective tissue, or of a spindle-celled stroma identical with that of the normal ovary, or of both these constituents. The spindle cells have been identified by some observers as connective-tissue corpuscles; by others as unstriped muscle; or in some cases as sarcoma cells. The fact that the spindle cells of such tumours are for the most part indistinguishable from those of the normal stroma, and that in solid tumours the development of these cells into fully formed connective-tissue may often be distinctly traced, should lead the observer to hesitate before describing a tumour as a myoma, or as a spindle-celled sarcoma, on anatomical evidence alone.

The connective tissue of cyst walls varies greatly in vascularity; the greater the bulk of solid tissue the more vascular it is: the walls of unilocular cysts with fluid contents are often parchment-like and almost bloodless.

All cystic tumours, with the exception of those formed by degeneration from solid growths, are lined more or less by epithelial structures,



upon which their cystic character depends. Now, excluding the lining of the vessels, epithelium is present in the normal ovary in two forms only: firstly, as the germ epithelium covering almost the entire surface of the organ; and, secondly, as the epithelium lining the Graafian follicles. These parts we should naturally regard, therefore, as the seats of development of all cystic tumours. No author now regards the epithelium of the vessels as the source of cystic tumours; and the evidence of many observers is accumulating in favour of the follicular source of most ovarian cysts. We are, however, still unable to explain the great differences which are found not only in the several tumours, but also in the several compartments of the same tumour.

*Hydrops Folliculorum.*—The simplest cysts are the small unilocular dilated follicles known by this name. They are generally multiple and small in size; although occasionally a single cyst may be as large as a fist, a man's head, or even yet larger. When the cysts are minute, the ovary may be but little enlarged, some of them projecting on the surface, others lying deep in the stroma. The fluid contained in these cysts, as in all ovarian cysts, may be clear or blood-stained. The lining membrane is clear and transparent, and covered with columnar epithelium. As a rule the cysts are few in proportion to the amount of stroma; but occasionally they are very numerous, and the stroma so scanty that the ovary is converted into a small mass of delicate cysts.

It is quite common to meet with ovaries, otherwise healthy, with a single unilocular cyst as large as a pigeon's or a small hen's egg; it is situated usually at the outer extremity.

The causation of these cysts is probably a very simple matter. It is believed that the normal rupture of the follicles is prevented by a thickening or undue toughness of their walls, resulting, perhaps, from inflammation; and this leads to an increased accumulation of their fluid contents. Occasionally ova can be detected in them. Such cysts have been known to occur in the foetal ovary.

These forms of cystic ovary rarely give rise to symptoms, or interfere with the normal functions of the organ; menstruation, ovulation, and pregnancy take place in their usual course. Progressive enlargement beyond a moderate size is not common, and any of the cysts may rupture and be cured spontaneously.

*Cystic Corpora Lutea.*—These also are unilocular cysts, and are usually of the size of a pigeon's egg; though occasionally they have been found as large as a small apple (Gottschalk and Nagel). They were first described by Rokitsky. The wall is comparatively thick, and is lined by the yellow and apparently folded membrane characteristic of these bodies, altered by pressure and stretching, and stained by the blood which usually forms their contents. Careful observation of this lining membrane by the eye and the microscope will distinguish them from other small cysts containing blood. It will not be possible to explain the occurrence of these cysts until our knowledge of the natural history of normal corpora lutea is more complete. I have examined specimens which have led me

to believe that a corpus luteum may be developed in an unruptured follicle; if this be correct, dropsy with subsequent hæmorrhage from the very vascular lining membrane is a reasonable explanation of the cysts.

*Proliferating Cystoma.* — I now come to a far more difficult and complicated class, the various forms of proliferating cystoma. This class comprises the great bulk of ovarian cystic tumours. They vary greatly in size: occasionally they are met with at an early stage, and are then very small; if not removed by operation they may attain enormous dimensions, so that the emaciated woman may almost appear to be an appendage to the tumour.

These tumours are composed of a greater or smaller number of primary cysts which contain secondary cysts in their walls, or projecting in more or less solid masses into their cavities. There is every variety of size in the primary and secondary cysts. Usually one or more greatly exceed the others in bulk: many of the cysts rupture and communicate with each other by small or large openings in the septa; in consequence some disappear, and are recognised by an orifice in a septum closely compressed against the inner surface of the larger cysts. The very large cavities are usually, if not always, formed in this manner.

A cyst composed of a few thin-walled cavities may by fusion become practically if not strictly unilocular.

Fusion of cystic tumours of both ovaries may also occur in the same way, and form a single tumour, the nature of which may be recognised by the presence of two characteristic pedicles, one on each side of the uterus.

*Structure.* — The cyst walls are composed mainly of dense, more or less vascular connective tissue, arranged chiefly in bundles of long white fibres; the most recently formed parts contain also the characteristic spindle cells of the ovarian stroma, and in the neighbourhood of the pedicle non-striated muscle fibres have been found by Olshausen and others.

The walls, therefore, if at all thick, are very tough and strong; some, however, being naturally thin, or being weakened by papillomatous growths, secondary cysts, or some partial degeneration, may rupture from very slight or inappreciable exciting causes.

The epithelium is polymorphous; cylindrical, ciliated, and goblet cells being the principal forms: the cells are sometimes quite irregular in shape, sometimes flattened, and sometimes even absent. Usually they form a single layer, sometimes several layers. Where proliferation is taking place cup-shaped depressions occur which, gradually invading the cyst wall and becoming closed at their mouths, form secondary cysts. Groups of cysts thus formed may project into the principal cavity and make semi-solid masses, which not rarely attain considerable size. On section these masses are seen to be composed of small secondary cysts, and they may thus be distinguished from the papillomatous growths occasionally found in these cysts.

Much less frequently there are found in some of the cavities of these

tumours connective-tissue buds covered with columnar epithelium in the form of dendritic masses which may fill the containing cysts. Sometimes they perforate the wall of the cyst and spread to adjacent ones; or, if the main cyst wall be perforated, they spread over the adjacent peritoneum, and particles, becoming detached, may be carried to distant parts of the abdominal cavity and grow there. Such papillomatous masses may be found with three different characters:—(i.) Developing in certain loculi of otherwise typical proliferating cysts. (ii.) Developing in the principal cyst and in any secondary cyst—such tumours are as a rule not very large, and show a tendency to invade the broad ligaments. (iii.) Developing on the surface of the ovary without any evidence of having been previously contained in a cyst. Such cases are very rare, and are well described as “surface-papillomas.”

A different origin is, of course, possible in some cases of surface-papilloma; the growths may originally have been developed in a cyst which was perforated and has entirely disappeared.

Microscopic sections of these masses closely resemble transverse sections of the middle and outer parts of the Fallopian tube; there is little tendency to the formation of cysts. Small sand-like concretions, called psammomas, are frequently present in them, and are sometimes also found in the walls of proliferating cysts.

It will be noticed that the proliferating cysts are lined almost uniformly by structures closely resembling certain mucous membranes with their simple tubular glands; and as a result the term “glandular” has been applied to them. Waldeyer, Bland Sutton, and others have drawn attention to these resemblances.

Papillary cysts are more frequently bilateral than the proliferating cysts. The rare surface-papilloma is generally accompanied by abundant hydroperitoneum. In the latter case Olshausen states that the cubical surface-epithelium of the ovary is directly continuous with and gradually lengthens into the columnar epithelium of the papilloma.

Recently Whitridge Williams (37) has carefully investigated the papillary tumours of the ovary. He is of opinion that only a small proportion of them invade the broad ligaments, while at least half of them are bilateral. He finds that they are lined by a single layer of columnar cells, except at points where new papillæ are being formed, when the layers are multiple. The epithelium is often, but not invariably ciliated. He also finds the same characters in surface-papilloma, of which he has collected twenty-six well-described cases. The entire surface of the organ may be covered with papillæ, the ovary itself being almost unchanged; although at times epithelial processes and duct-like structures may be found to extend into the stroma, and from these papillomatous cysts may arise in the substance of the ovary. Psammomas are present in large numbers. He believes that the surface papillomas arise from the germ epithelium.

*Contents.*—The fluid contained in proliferating cysts is usually viscid; but it varies greatly in consistence and colour in different tumours,



and even in different cavities of the same tumour. In some it is so viscid that it will not flow, and has to be removed in handfuls from the cysts or the peritoneal cavity; in others it is quite thin, and every intermediate degree of viscosity may be found. The fluid is at first colourless, and either transparent or opaque; but from admixture with blood and subsequent changes, the colour may vary through every shade of blood-red to brown, green, or yellow.

The specific gravity varies from 1·002 to 1·020, the average being perhaps about 1·012; higher that is than in the case of broad ligament cysts, and some papillomatous cysts.

Histologically the fluid, however viscid, is structureless; though at times a delicate connective-tissue reticulum may be found in colloid material. Blood corpuscles are often present, and epithelial cells which vary, of course, in character, and in the different degrees of degeneration. Sometimes crystals of cholesterin are found. The reaction is neutral or alkaline. Various forms of albumin are present in solution, such as metalbumin, paralbumin, albumin peptone, and so forth; to these bodies the viscosity of the fluid is due.

*Dermoid Structures in Ovarian Cysts.* — These form a very remarkable and not common variety of ovarian tumours (3·5 per cent according to Olshausen). Both structurally and clinically they present characteristic features, by which they may be recognised. There are three principal varieties of these tumours, which are always cystic: (i.) A unilocular cyst possessing the characteristic features. (ii.) A cyst with two or more cavities each with characteristic dermoid contents; the component cysts having probably arisen independently, not by proliferation. (iii.) An ordinary proliferating cyst, one or more cavities of which contain characteristic dermoid structures. Out of thirty-one dermoid cysts Doran records four of this kind.

The anatomical structures characteristic of these, as of all dermoid tumours, are portions of true skin present in the cyst wall. Occasionally, perhaps, the whole cyst may be lined with cutaneous structures, but usually there is only a relatively small, well-defined patch of skin.

Section of these patches reveals the histological characters of true skin; often with the hair, sweat and sebaceous glands resting on a layer of subcutaneous fat which unites it to the cyst wall. Teeth, bone, cartilage, and, much less frequently, other structures — such as non-striped muscle and nerve tissue — may be found in different parts of the cyst wall.

The dermoid mass sometimes curiously resembles the mamma in shape, and may even present a rudimentary nipple, as described by Von Velits, Bland Sutton, and others. The mass is, however, composed not of mammary gland tissue, but of fat; the gland tubes present being obviously modified sebaceous and sudoriparous glands.

The hair is developed from follicles in the ordinary way, and may grow to a considerable length: it is often detached, and then, if long, may be coiled up into balls; or if short, mixed up with the other contents of the cyst. The colour bears no necessary relation to that of



the normal hair of the individual. Irregular plates and masses of bone, and occasionally nodules of cartilage, are found embedded in the cyst wall. Teeth may be found projecting from these bony plates; they are often irregular in shape and vary greatly in number: usually they are few, but as many as 300 have been described by Antreich. The characters of these dermoid teeth have been fully described by Mr. Bland Sutton. Nails have been found by Cruveilhier and others. Mr. Knowsley Thornton records a dermoid containing a mass like a malformed limb with long nails at the extremity.

Dermoid cysts usually contain a thick, white, pultaceous or putty-like substance, consisting of fat, cholesterin, epithelial cells and hair, which may be rolled up into coils or balls. The fat is sometimes fluid at the body temperature. Occasionally large numbers of small solid balls of fat are found. Bland Sutton has described one containing several hundreds of these bodies; each one examined had a short hair coiled up within it.

Dermoid cysts, like the other varieties, may contain sarcomatous or carcinomatous masses; and there is reason to believe that they are more often followed by malignant secondary growths than are the other forms of cysts.

A remarkable case of Martini's is recorded by Kolaczek, who on removing a dermoid cyst found the peritoneum studded with numbers of small yellowish bodies the size of peas, many of which contained a thin woolly hair attached to the peritoneum. He supposed that they arose as a result of rupture of the cyst.

*Hydatids of the Ovary.* — There is very great doubt whether any of the cases so recorded are really hydatids of the ovary; most probably they are examples of hydatid cysts involving but not originating in the ovary.

Schultze, in 1893, operated on a woman 32 years of age, and removed from the abdomen 30 hydatid cysts: the largest was 6 inches in diameter, and the right tube was stretched over it; it was apparently a cyst of the right ovary. The left ovary and tube were healthy. Several cysts had to be left behind, but the patient made a good recovery. Schultze admits there was no proof that the disease originated in the ovary.

*Malignant Growths in Ovarian Cysts.* — The presence of malignant masses in the walls of different varieties of ovarian cysts has already been referred to. The well-known clinical fact that a certain number of women die from malignant disease after ovariectomy, in whom at the time of operation the tumour was thought to be benign, is probably to be explained by the non-recognition of such malignant masses.

Landerer gives details of three cases of proliferating cystoma with malignant growths in the walls. In two there were secondary growths in the tube of the same side, and in one both tubes were affected. Secondary nodules were also found in: — (i.) The utero-vesical cellular tissue and broad ligaments. (ii.) The mesentery, and parietal and visceral peritoneum. (iii.) The abdominal surface of the diaphragm.

(iv.) The retro-peritoneal, inguinal, mediastinal, and bronchial glands.  
 (v.) The parietal and pulmonary pleura. (vi.) The liver.

The growths in the cyst wall were carcinomatous, arising from proliferating (glandular) processes of the lining epithelium, which were hollow or in some places filled with polymorphous cells; in others lined with columnar epithelium or dilated into small cysts. In other places well-marked alveolar cancer was present.

In such cases metastasis occurs through the blood or lymph channels, or by the migration of detached particles to distant parts of the peritoneal cavity.

Landerer justly remarks that if apparently simple ovarian cysts may thus become the seat of carcinomatous growths, it is wise to remove all such tumours, however small, immediately they are detected. In the case of papillomatous cysts, it is not very uncommon at the time of operation to find that secondary papillomatous growths are present in the parietal or visceral peritoneum. These secondary growths probably arise by detachment and migration of papillomatous particles from a cyst which has become perforated, and from which papillomas protrude. This simple explanation does not, however, apply to cases in which secondary papilloma has been found upon the pleura; in such cases distribution must, of course, occur through the blood or lymph channels as in the case of true malignant metastasis. Indeed, it seems clinically established that papillomatous cysts are more nearly allied to malignant disease than are the simple proliferating cysts. It is a curious, but well-established fact, that secondary papillomas, not removed at the time of operation, disappear after the removal of the principal growth, and in no way prejudice the ultimate result of the operation.

*Solid tumours of the ovary*, according to Olshausen, form about 5 per cent of all ovarian tumours. Like cystic tumours they may be either innocent or malignant; they may also undergo cystic degeneration.

The larger innocent tumours are composed of spindle-celled tissue similar to that of the normal ovarian stroma, with two well-marked differences; namely, the tendency to develop into pure fibrous tissue, and the tendency to softening of the fibres, leading to the formation of cyst-like cavities like those which occur in uterine fibroids. Cysts may also arise by lymphangiectasis. Occasionally calcification is met with.

Solid tumours, whether innocent or malignant, are often bilateral; and this condition is therefore no important evidence of malignancy.

The name fibroma is obviously correct for such tumours as these; those who, like Mr. Doran, apply the name myoma must satisfy themselves that the normal ovarian stroma is principally non-striped muscle.

This variety of tumour is distinctly rare, but is probably the most common form of solid ovarian tumour. In general character it closely resembles the harder uterine fibromyoma: there is, however, one clinical distinction of great importance; namely, that they are frequently accompanied by hydroperitoneum. Being very slow in growth and

generally discovered early, they do not attain a very large size. As they are formed by hyperplasia of the whole stroma, they maintain the general contour of the ovary. As a rule they are freely movable, having no adhesions, and are surrounded by fluid. The oviduct, though often thickened, apparently by simple hyperplasia, is not stretched over the growth, as in the case of cystic tumours, but lies free, because the mesosalpinx is not opened up by the growth.

The tumours sometimes contain small cavities or cysts, rarely large ones; these may be formed by dilated follicles, lymphangiectasis or softening of the constituent fibres; proliferating or papillomatous cysts have not, I believe, been met with in the same ovary.

There is a peculiar form of fibroma of the ovary which, as it leads to no great enlargement of the ovary, is generally met with in the dead-house, or accidentally during operations. The ovary may be as large as a small hen's egg, and is irregular in shape. On section the enlargement is seen to be due to the presence of one or more, sometimes of many oval bodies the size of peas or beans, well defined from the rest of the stroma by being paler in colour, and showing a sinuous arrangement of the fibre bundle. They are found to consist of well-developed white fibrous tissue, which stains with difficulty, and is less vascular than the surrounding stroma. They are identical, except in size, with corpora lutea in their penultimate stage; and undoubtedly they are corpora lutea which have undergone hypertrophy instead of atrophy. The largest specimen I have examined was the size of a walnut; it contained a considerable number of these bodies.

They have also been described by Rokitansky, Klebs, and Klob. In Klob's case the tumour was as large as the fetal head. In Rokitansky's cases the largest was no bigger than a walnut.

Dr. Mary Dixon-Jones has described and figured this form of tumour under the appropriate name of gyroma; but she believes these growths to be closely connected with those described as endothelioma of the ovary, and that they are developed from corpora lutea when found in the cortex, from endothelium when found in the medulla.

The term "endothelioma" was first applied by Leopold, in 1874, to a peculiar form of fibroma of the ovary, containing numerous alveolar spaces packed with epithelioid cells. He traced the origin of these spaces to dilatation of lymphatic and capillary channels, with proliferation of their endothelium; hence the name. Similar tumours have been since described by Marchand, Rosthorn, Amann, and others. The last author made the interesting observation that certain typical sarcomas of the ovary could be traced back to proliferation of the adventitia of the smaller vessels, others to proliferation of the endothelium of lymphatics and capillaries. Although there is much still to be learned about these tumours, it seems well established that they really do arise from the walls of lymphatics and blood-vessels, and that they must be regarded as closely allied to sarcoma.

*Sarcoma of the Ovary.*—All authorities are agreed that our knowledge

of this form of malignant growth is very imperfect. Primary sarcoma and carcinoma, in the form of solid tumour, are rare.

Olshausen says that "the spindle-celled form of sarcoma is the most common; mixed round and spindle-celled forms are met with, but true round-celled sarcoma is very rare."

The consistence of these tumours varies much; generally they contain cysts, and in size they may equal the fœtal head at term. The bundles of spindle cells do not differ materially from those of the normal stroma, and between them are often large numbers of round cells. These tumours are closely related on the one hand to fibroma, and on the other to adenoma and carcinoma.

*Sarcoma carcinomatosum* has been described by Spiegelberg, who says, "The tumours consist for the most part of round-celled sarcoma. In certain parts are large alveoli separated by a very vascular connective tissue, and containing large cells undergoing fatty degeneration, the whole being quite like carcinoma."

Secondary sarcomatous growths are found most frequently in the stomach, liver, intestines, pleura, and peritoneum.

Mr. Bland Sutton says, "It is important to remember that the majority of solid ovarian tumours classed in museums as fibromata are examples of sarcomata." This statement requires further proof before it can be accepted; it is at least certain that many tumours classed as sarcoma are really fibroma. Sutton also says that sarcoma of the ovary grows very rapidly; this forms a very important clinical distinction, as fibromas grow very slowly.

What is needed to settle these questions is that every solid ovarian tumour shall be carefully examined by a competent histologist, and its characters recorded with the after histories of the patients, which, unless death occur soon from some other disease, will give the most important evidence as to the malignancy or otherwise of the tumour.

*Carcinoma of the ovary* is still rarer than sarcoma; as already stated, however, carcinomatous growths are not infrequently met with in cystic tumours. According to Olshausen the disease in 50 per cent of cases is bilateral, and the medullary form is the most common. The tumour may be as large as a man's head.

Mr. Shattock has recorded a case of columnar-celled cancer of the ovary, forming a large tumour 11 inches by 5 inches; this variety is, however, very rare.

The greater number of recorded cases are clearly secondary; but there is no doubt that cancer may arise primarily in the ovary. Bland Sutton points out that as typical adenoma is met with in the ovary there is reason to believe that cancer may also occur there; for experience shows that wherever adenoma occurs cancer may also appear. Positive observations have, however, been made by Steffek and others.

Steffek was able, in one instance, to trace to his satisfaction the origin of the cancer to the epithelial lining of the Graafian follicles, thus proving conclusively the possibility of a primary origin of the disease



in the ovary. Doran records a case of alveolar cancer in a girl of fifteen.

*Cysts of the Broad Ligament.* — A considerable number of cysts, removed by ovariectomy (11 per cent according to Olshausen), are found to occupy one or other broad ligament. Some of these have arisen in the ovary and gradually invaded the broad ligament; such cysts have probably originated near the hilum, although not necessarily in the parovarium. Both proliferating and dermoid cysts may be thus found in the broad ligament. The greater number, however, arise in the broad ligament, are independent of the ovary, and have distinctive characters. They are thin-walled and usually unilocular; although occasionally they contain a few distinct cavities, and possess a loosely attached coat of peritoneum which can easily be separated from the true cyst wall. They contain a clear or opalescent watery fluid of low specific gravity (1.002 to 1.008), which contains chlorides but no albumin. The epithelial lining may be columnar (when it is often ciliated), or cubical; at times the cyst is lined merely by a thin layer of hyaline substance.

The oviduct is stretched over the cyst, and often is greatly elongated; it does not communicate with the cyst cavity as in tubo-ovarian cysts. It always remains patent.

The ovary may be found free, or stretched and flattened against the cyst wall.

The smaller and medium-sized cysts are sessile, being contained entirely within the broad ligament; the larger cysts often develop a broad pedicle easily dealt with surgically.

Mr. Doran has carefully investigated and described an uncommon form of broad ligament cyst, namely, the papillary form, identical with papillary cysts of the ovary. He believes that they all arise from the parovarium; those of the broad ligament from the vertical tubes of that body, those of the ovary from the prolongation of the parovarium into the hilum. Doran also points out that no case of proliferating cyst of the broad ligament has ever been described in which the ovary was not the seat of origin. The common broad ligament cysts, he believes, are developed outside the parovarium; so that the name parovarian cannot be accurately applied to them.

Minute cysts are also often found above the tube and in the mesosalpinx, quite distinct from the parovarium; also cysts may be formed by distension of the hydatid of Morgagni. None of these, however, attains such a size as to be clinically recognisable.

**Etiology.** — The investigation of the origin of ovarian tumours includes two distinct parts: (i.) The anatomical structures from which they arise; (ii.) The conditions which cause them. Of the latter subject we know nothing; and there is much difference of opinion and uncertainty concerning the former. It is not worth while, in this article, to do more than recapitulate briefly the views of the most important observers.

It is obvious that the chief difficulty lies in determining the origin

of the epithelial structures, which for the most part determine the characters of the cystic, papillary, and carcinomatous tumours. The connective tissue, and such unstriped muscle as may be present, are without doubt developed from these elements of the ovarian stroma.

Hyaline degeneration of blood-vessels, of abortive follicles, and of corpora lutea have been regarded by some authors as important factors in the origin of ovarian tumours; but I am unable to regard this passive melting of degenerating tissues as having any but a subordinate importance in relation to structures bearing such evidence of vigorous growth as do most ovarian tumours.

With the exception of the endothelium of the vessels, the only epithelium that exists in the ovary is (*a*) the germ epithelium which covers the ovary at all stages, and from which (*b*) the epithelium of the Graafian follicles is probably derived, and (*c*) the epithelium of the parovarian tubes prolonged into the hilum. It is probable that observers, in their anxiety to find a solution for these etiological problems, have been led to draw their conclusions from well-defined types, and to neglect the numerous mixed forms which are met with (*vide* *Intro.*, vol. i. of this System, p. xxix). The result is that no sufficient explanation has been found for the occurrence of these mixed tumours.

It is difficult to accept a different site of origin for papillomatous and proliferating cysts when both may be found in different compartments of the same tumour. And with regard to dermoids, a hypothesis which only accounts for the distinctively dermoid portion of a mixed cystic tumour is not a sufficient explanation of the origin of the whole tumour.

*Proliferating Cysts.* — According to Virchow, Rokitansky, and Rindfleisch, these tumours arise in the ovarian stroma by colloid degeneration of the connective-tissue cells or intercellular substance. Führer, Klob, Doran, Sutton, and I may add almost all recent investigators, believe that they arise from Graafian follicles. Another view was advanced by Klebs and Waldeyer, and supported more recently by de Sinéty, Malassez, and Fleischlen: these observers believe that they arise from certain tubular ingrowths of the germ epithelium found in early foetal ovaries, and associated with the development of the Graafian follicles. These ingrowths are known as Pflüger's tubules. Such evidence as there is to hand certainly appears to favour the view that these cysts arise in the Graafian follicles.

*Papillary Cysts and Tumours.* — Many observers, among whom may be cited Olshausen, Fischel, and Doran, believe that papillary cysts arise from the paroöphoron, some tubules of which have been repeatedly traced into the hilum of the ovary. On the other hand, Marchand and Fleischlen have satisfied themselves that these cysts also arise from Pflüger's tubules. The most recent writer upon the subject is Dr. Whitridge Williams, who has been able to demonstrate the origin of papillary cysts from: (*a*) germinal epithelium; (*b*) the Graafian follicles. Surface-papillomas he proves to arise from the germ epithelium. He is not satisfied with the evidence adduced to prove that papillary cysts arise from

relics of the paroöphoron in the hilum of the ovary, and believes that their origin from the epithelium of the Fallopian tube, although possible, has yet to be demonstrated. According to the statistics of various operators, the proportion of papillomatous cystomata to glandular cystomata is as one to ten. When it is remembered that mixed papillary and proliferating cysts are by no means rare, it appears most probable that they arise from the same structures; if so, the difference of their characters must depend upon some other cause.

*Dermoids.*—The etiology of these tumours is quite obscure. The theory most generally accepted is that here, as in other parts of the body, they are developed from minute fragments of epiblast included in the ovary at a very early period of development.

It must be remembered, however, that this ingenious and widely accepted view is by no means a complete explanation: the occurrence of mixed forms of dermoid and proliferating cysts points to a follicular rather than an intestinal site of origin.

**The Natural Progress of Ovarian Tumours.**—The majority of ovarian tumours, being proliferating cysts, grow much more rapidly, in their advanced stages, than ovarian dermoids and the solid tumours both of the uterus and ovaries; some malignant tumours excepted. Owing to their greater mobility, and to their often unequal increase in size, their position in the abdomen varies much more than that of the gravid uterus.

Our knowledge of the early stages of ovarian tumours is very small; for it is only occasionally, and almost by accident, that small ovarian tumours are discovered: they may attain a large size before the patient is led to seek medical advice. In the early stages the rate of growth is probably quite slow; in the case of dermoids and benign solid tumours it is slow throughout. Rapid increase in size, to such an extent that it can be recognised almost from day to day, is the result of hæmorrhage into a cyst. This is a complication almost equalling in importance the occurrence of concealed accidental hæmorrhage in the gravid uterus.

If the uterus and broad ligaments are normal in position the ovary, enlarged by early cystic disease, lies at first in the usual position on the superior and posterior surface of the broad ligament on one side of the middle line. As it increases in bulk the tumour rarely remains in the posterior pelvic pouch, but rises in the direction of least resistance, and displacing the bowels, gradually comes into contact with the anterior abdominal wall; then, if free to move laterally, it tends to assume a more central position. The pedicle formed by the attachment of the ovary to the broad ligament, while at first anterior and inferior to the tumour, is now as a rule directly beneath, and sometimes posterior to it; the tumour lying more directly above the uterus. It is supported by the brim of the pelvis, causing little or no discomfort to the patient and, if the pedicle be long enough, no displacement of the uterus. Occasionally the tumour becomes impacted in the pelvis; either from irregularity of enlargement of its component cysts, or from the formation of adhesions.

Rarely the pedicle may remain anterior, and the broad ligament is then pulled up in front of the tumour leading to lateral displacement and fixation of the uterus; and so to difficulties in diagnosis.

Again, in the exceptional cases in which the tumour develops in the hilum of the ovary, it may separate the layers of peritoneum, and invade the broad ligament and the pelvic cellular tissue continuous with this. As a result the uterus becomes much displaced laterally and, its mobility being restricted, the diagnosis is obscured.

Not infrequently the tumour is found to occupy the utero-vesical pouch of peritoneum, the uterus and broad ligaments lying retroverted behind it.

When the tumour is once fairly upon the pelvic brim its further enlargement usually leads, by pressure on the abdominal walls and viscera, to a gradually increasing prominence of the abdomen suggestive of pregnancy; the bowels being displaced upwards and laterally as in the case of the gravid uterus. At this stage it is usually recognised and removed; but if it continue to increase the enlargement of the abdomen becomes very great, the diaphragm is pushed upwards, the lower part of the thorax becomes expanded, and severe pressure symptoms result. Cases are recorded in which the enlargement of the abdomen was so great that the head and limbs of the patient appeared to be mere appendages to an enormous abdominal tumour.

In such cases of great abdominal distension, the effects of pressure on the organs of respiration, circulation, and digestion become so marked that the consequent suffering and emaciation of the patient lead to a characteristic facial expression; not rarely seen in former days when, owing to its great mortality, the operation of ovariectomy was usually postponed as long as possible.

Doran has drawn attention to the frequency of dilatation of the ureters, with chronic interstitial changes in the kidneys, found in fatal cases after operation; he believes that these changes are the result of the pressure of the tumour.

The development of ovarian tumours does not, as a rule, interfere with ovulation and menstruation; and, although both ovaries may be the seat of considerable tumours, so long as a portion of healthy ovarian tissue remains, these functions may be unaffected. Mr. Thornton has recorded a case of pregnancy with bilateral dermoid cystic disease; the relic of healthy ovarian tissue being indicated by the presence of a corpus luteum in the wall of one cyst. But amenorrhœa may occur from great deterioration of the general health, produced by the size and pressure effects of the tumour, or by its malignancy.

In the case of solid tumours, which are so often bilateral, amenorrhœa, if present, may be due to the total destruction of Graafian follicles which usually occurs in these cases.

**Complications.** — Cystic tumours only occasionally cause hydroperitoneum, solid tumours frequently do so; the reason for this difference is not known: nor is it known why solid tumours of the ovary should do so when similar tumours of the uterus do not.



If much fluid be found associated with a cystic tumour, it is most likely to be due, in the absence of surface or perforating papilloma or other extraneous causes, to leakage from one or more of the cyst cavities into the peritoneal sac. It is frequently due, of course, to pressure of the cyst upon the vena cava and great abdominal veins. In the same manner œdema of one or both legs may occur, and in rare cases distension of ureters and renal pelves.

The most frequent complication is that which leads to the formation of adhesions to adjacent structures; namely, to the omentum and intestines, oviduct, uterus, bladder, and abdominal wall. Such adhesions may be the result of acute inflammation of the cyst leading to local peritonitis, a complication to be next described; or they may arise passively and painlessly, without any symptoms to alarm the patient, or even to interfere with her usual occupation. A possible explanation of their occurrence is that the epithelium covering the cyst wall in its earlier stages may be removed by friction, and a fibrinous exudation would then occur leading to the formation of adhesions between the adjacent surfaces. Such adhesions may be more or less dense and extensive, or merely thread-like; sometimes, especially when connected with the omentum, they may contain vessels so large as to become an important source of blood-supply to the tumour. Dermoids appear to be more frequently complicated by adhesions than are other tumours. Cysts of the ovary adherent to the bladder or rectum may form communications with either viscus, and, in the case of dermoid cysts especially, with curious results: a lock of hair may be found protruding from the urethra or anus; or bones, teeth, and other contents of these cysts may be evacuated.

Tubo-ovarian cysts usually arise in a similar manner; they are described later (p. 801). Adhesions are chiefly important in respect of the difficulties they make for the operator; in some cases, indeed, the operator has great difficulty in determining whether he is dealing with the parietal peritoneum, the cyst wall, or some adherent viscus.

*Acute Inflammation of Cysts.*—This is usually a spontaneous complication. In the pre-antiseptic period it was a common result of tapping the cyst for the purpose of diagnosis or treatment; and, together with septic peritonitis, was not uncommonly one of the causes of the death of the patient. Apart from this it occurs most frequently in connection with conditions which interfere with the vitality of the tumour; such are acute torsion of the pedicle, injury by pressure, and strangulation during labour. Under such conditions pyogenetic organisms appear to enter from the intestinal canal, and lead to suppuration. It is probable also that an acutely inflamed Fallopian tube becoming adherent to a cyst may infect it without the actual formation of a tubo-ovarian abscess.

*Torsion of the Pedicle.*—This complication, when acute, is one of great importance; for, unless recognised and dealt with by operation without delay, the danger to life is very great. A slight degree of torsion ( $\frac{1}{4}$  of a circle) is a common occurrence, and is probably due to the change of position which a small tumour undergoes as it rises from the posterior

surface of the broad ligament to a position of greater mobility above the pelvic brim. This slight degree of torsion does not produce symptoms, and is probably persistent.

Under certain conditions, such as strain of the abdominal muscles, or in connection with the movements of the intestines, or from unequal enlargement of some of the component cysts, this slight torsion becomes increased gradually or suddenly, with results which vary with the suddenness and degree of the strangulation. In the slowly produced cases the circulation is gradually obstructed; as a result, the growth of the tumour may be arrested. In rare cases atrophy of the twisted pedicle is so complete that the tumour becomes more or less separated from its original attachment; its vitality may then be maintained by a blood-supply obtained from the adherent viscera, most commonly from the omentum. If no such adhesions exist, the tumour lies free or almost free in the peritoneal cavity, and gives rise to considerable hydroperitoneum. Acute torsion is a far more serious matter; the sudden interference to the return of blood from the tumour frequently leads to hæmorrhage into it, and consequently to rapid enlargement. The tumour also becomes very tender, and the condition comes to simulate cases of moderately acute latent accidental hæmorrhage in advanced pregnancy. I have seen a case in which, in a young patient, torsion of the pedicle led to severe hæmorrhage into the cyst; as a consequence of this accident it ruptured into the peritoneal cavity, which was filled with blood. The symptoms were very urgent. The patient, however, made an excellent recovery.

In other cases strangulation of the pedicle interferes with the vitality of the tumour, and allows it to be rapidly invaded by septic micro-organisms, resulting in an acute inflammation of the cyst and peritoneum which necessitates immediate operation.

Hermann W. Freund has discussed the mechanism of torsion of the pedicle, and suggested that a law may be laid down that right-sided tumours rotate to the left, and that left-sided tumours rotate to the right; he admits, however, that there are many exceptions to this law. Professor A. R. Simpson has also illustrated the same law by three cases. Freund quotes ten cases; in six only was the pedicle twisted, in four the rotation was right, and in two left sided. Of the four which rotated to the right, two were right tumours, and two left; and of the two which rotated to the left, one was a right, the other a left tumour. Out of sixty-six cases of ovariectomy at St. Bartholomew's Hospital, between August 1892 and October 1894, there were fifteen cases of torsion of the pedicle of ovarian cysts, and one of a broad ligament cyst. Of ten left-sided tumours, six were twisted in the opposite direction to the movements of the hands of a watch, that is, from right to left; and four in the same direction, that is, from left to right. Of five right-sided tumours three were twisted from left to right, and two from right to left. These numbers are not large enough to decide the question of Freund's "law"; but they suggest that the direction of rotation does

not present a constant relation to the side to which the tumour is attached.

*Incarceration of Ovarian Tumours in the Pelvis.* — This is a rare complication; but it is found occasionally in the case of tumours which invade the broad ligament, and which having no pedicle are greatly restricted in their mobility. Still more rarely a pedunculated ovarian tumour may become incarcerated in the retro-uterine pouch of the pelvic peritoneum, giving rise to retention of urine; as in the far less rare cases of incarceration of uterine fibroids or extra-uterine gestation cysts. In St. Bartholomew's Hospital Museum is a rare specimen (No. 2951 c) of a dermoid cyst adherent to the uterus, and causing retention of urine. This was unrelieved, owing to the common mistake of not recognising that constant dribbling of urine following retention is a symptom of extreme distension of the bladder.

*Rupture of Cystic Tumours.* — This occurs in three forms: (a) Rupture of a thin-walled unilocular cyst, leading to a sudden disappearance of the tumour, and the presence of free fluid in the peritoneal cavity. In these cases the cyst usually fills again. (b) The rupture of one or more loculi of a multilocular cyst, leading to constant leakage into the peritoneum, and thus to the presence of a cystic tumour with free fluid. (c) The perforation or rupture of a cyst, or parts of a cyst containing papillomas, followed by the detachment and escape of particles, and the spreading of the growth over adjacent parts. The rupture may occur spontaneously, or during a medical examination, or in consequence of injuries, such as falls or blows. If the contents of the cyst are aseptic, as is usually the case, the immediate effects are slight. Unless hæmorrhage occur there is little pain or shock, as a rule; although sometimes these are marked. The tumour of course disappears, and occasionally does not reappear. The fluid, if thin, is rapidly absorbed by the peritoneum, and excreted by the kidneys; a condition of polyuria persisting for some days. If the fluid is viscid it accumulates in the peritoneal cavity, the cyst continually leaking; gradually it occupies all the peritoneal spaces between the bowels, and even the more distant parts between the liver and the diaphragm, so that it becomes very difficult to remove it entirely at the operation.

A case of infection of the peritoneum with dermoid growths after rupture of the primary tumour has already been mentioned; and the spreading of papillomatous growths in this way is well known. Such secondary growths are benign; and after removal of the main tumour, although the infected peritoneum is very imperfectly dealt with, spreading ceases, and the patient makes a permanent recovery.

*Pregnancy and Labour complicated by Ovarian Tumours.* — Ovarian tumours form a very important complication of pregnancy and labour. The difficulty during pregnancy is in the diagnosis, not in the treatment: experience shows that ovarian tumours may be safely dealt with at any period of pregnancy; and as a general principle should be so dealt with.

Labour may be complicated by the presence of an ovarian tumour in



the abdomen or in the pelvis. In the abdomen tumours may be of considerable size without doing much harm; but if even a small tumour occupy the utero-sacral pouch of the pelvis it will cause obstruction, and must be dealt with. Most of these are cystic tumours; but a case of fibroma of the ovary has been recorded by myself which during labour simulated the head of a second extra-uterine fœtus.

Cystic tumours have been driven down by the advancing fœtal head, and have burst through the posterior vaginal wall, so that the tumour has been spontaneously delivered before the fœtus.

Sometimes it is possible, under deep anæsthesia, to raise the tumour above the pelvic brim, and so out of the way; especially during the earlier stages of labour.

When the obstructing tumour is a thin-walled cyst, simple puncture through the posterior vaginal wall will be the best method of dealing with it for the time. When this is not successful, owing to its multilocular character, or when the tumour is solid, there can be no doubt that abdominal section, followed, in certain cases, by the Cæsarean section and removal of the tumour, is preferable to dragging the fœtus past the obstructing mass. When this latter course is adopted, so much injury is done to the tumour, as a rule, that afterwards it becomes acutely inflamed, and the patient is placed in a state of very great danger.

**Diagnosis.** — *Ovarian and Broad Ligament Tumours.* — The diagnosis of ovarian tumours rests upon the recognition of their physical characters, for there are no symptoms of diagnostic value; the abdominal enlargement which attracts the patient's attention is generally her only complaint. Still this very absence of symptoms, coupled with progressive enlargement of the abdomen, is of value in the investigation of the case; and in the endeavour to set aside other abdominal diseases. It does not require a very large experience to convince us that, as Matthews Duncan said, until the abdomen is opened and the tumour exposed, the diagnosis of such cases is not one of scientific precision, but rather of a great probability; amounting, no doubt, in very many cases to practical certainty. This fact, coupled with personal recollection of mistakes, will make the physician cautious even in cases that appear to be simple, and still more so when they present unusual characters. In the large majority of cases, so long as the patient's health is not seriously affected by this or other causes, and the uterus itself is healthy, menstruation and ovulation continue unaffected by the disease. Interference with ovulation is of much more frequent occurrence in the case of the rare solid tumours than it is in cystic tumours. Too much stress has been laid by some authors on the presence of a tendency to amenorrhœa as a symptom of ovarian cystoma. It is far more correct to say that the absence of amenorrhœa and other menstrual disorders is the symptom of importance. That is to say, that in a woman having an abdominal tumour of pelvic origin, if the menstrual function remain normal it is of diagnostic value in favour of ovarian tumour; and as a symptom it must be considered as of equal value to the amenorrhœa of pregnancy and the menorrhagia of uterine fibroids.



Of the last 118 consecutive cases operated on in "Martha" ward at St. Bartholomew's Hospital up to March 1895—20 cases were in patients either before puberty or after the menopause. Of the remaining 98—in 73 menstruation was normal; in 7 there was amenorrhœa for short periods—3–12 months; in 3 the menstrual flow was lessened in quantity; in 3 menorrhagia was present; in 4 menstruation was increased in quantity, but the health was not thereby affected; in 8 menstruation was quite irregular as regards both time and quantity. These figures show that in about 75 per cent of cases of ovarian tumour menstruation continues unaltered during the twelve months preceding the diagnosis of the tumour; and that in the remaining cases increased loss is nearly as frequent as diminished loss. But in these cases of altered menstruation the possibility of a uterine cause must be borne in mind before the disturbance is assigned to the ovarian tumour.

Pain is an unusual symptom in cases uncomplicated by impaction, inflammation, or strangulation; and the pressure effects are usually not attended by much discomfort until the tumour has attained a considerable size. In rare cases the pressure appears to be the immediate cause of procidentia uteri, even in nulliparous women. I have seen two such cases in neither of which was the tumour impacted.

Matthews Duncan, in his *Clinical Lectures*, says with regard to the diagnosis of ovarian cystoma: "You get no aid from symptoms. Frequently there are and have been no symptoms; the case comes before you solely on account of size; or you may accidentally discover the tumour. Sometimes there are symptoms which may be described as resembling those of advancing pregnancy; only instead of the mammary and clavicular fat increasing as they generally do in pregnancy, you have them generally diminishing. Sometimes you have disturbance of menstruation. Sometimes you have a history of severe pain in the womb, or in one or the other ovarian region. Sometimes you are told the swelling began on one side. But all these indications vary much, and however they may be combined they form no basis for a diagnosis."

The first stage in the diagnosis of ovarian tumour is obviously the recognition of an abdominal or pelvic tumour. The second is the identification of the tumour as ovarian, partly by the recognition of its physical characters, partly by exclusion of other kinds of tumour. Both of these stages present difficulties, sometimes so great that nothing short of an exploratory opening of the abdomen is sufficient to determine the diagnosis; and there are cases of such obscurity that even this operation, in the hands of an experienced operator, followed by more or less complete evacuation of the contents of some cavity, may prove insufficient to determine the exact nature and origin of the tumour.

In the first place, let it be certain that the bladder is empty, using the catheter if there be any doubt on this point. It would be easy to quote examples of mistakes made, not by beginners only, from neglect of this simple precaution. Almost equally important is the clearing

out of the bowels; for fæcal masses are not infrequently mistaken for abdominal tumours. Next, and of first-rate importance, let it be always assumed that a woman, who is of the child-bearing age, and whose menstruation has been absent for a period of one to twelve months, is pregnant until absolute proof to the contrary be obtained. Mistakes in connection with pregnancy are the most common and the least excusable of any. How often do we meet with cases in which a simple normal uncomplicated pregnancy is diagnosed to be an ovarian cyst; and how often is a woman or girl suspected of pregnancy, sometimes even accused of it, when her only misfortune is an ovarian tumour!

The diagnosis of pregnancy, intra- or extra-uterine, when the fœtus is dead, of pregnancy with hydramnion or complicated with ovarian or other tumours of considerable size, is often difficult enough; but that of normal pregnancy, advanced to such a size as to form an abdominal tumour, is simple if the examination be systematic. This is not the place to go fully into the question of the diagnosis of pregnancy; but it may be mentioned that the easiest way of diagnosing this condition beyond the fifth month (that is, the fundus above the navel) is by palpation of the abdomen, when the hand may recognise parts of the fœtus floating in fluid, and some of them may present spontaneous movements. Next, in every case of obscurity, let the patient be put under an anæsthetic; and when muscular relaxation is complete, repeat the examination of the abdomen and pelvis. The general condition of the abdomen, fluctuation, and the area, site, and limits of the supposed tumour become far clearer when the abdomen is well relaxed; hence the aid of an anæsthetic is often invaluable.

*Recognition of Abdominal Tumour.*—This involves the recollection and the exclusion of conditions which simulate abdominal tumours: namely, enlargement of the abdomen by accumulation of fat in its walls and within it; distension by flatulent bowel and by fæcal masses; ascites; and masses of bowel matted together by adhesions, with or without much fluid effusion. Of these, certain cases of localised hydroperitoneum and cases of chronic peritonitis are apt to give rise to the greatest difficulties of diagnosis.

An ovarian tumour has usually a well-defined outline above and at the sides; it is often irregular, not rarely nearly spherical; usually there is a distinct feeling of fluid within it, with well-marked fluctuation in parts, if not in the whole mass.

The presence of fluctuation in all directions, and over the whole area of an abdominal tumour, proves the continuity of the fluid and the practically unilocular nature of the cyst; but this may be closely simulated in some cases of solid tumour in front of which lies a layer of free fluid.

Hard masses felt in an otherwise cystic tumour usually indicate secondary cysts, which when small are usually very tense and feel solid; they have no tendency to ballottement, and do not present spontaneous movements, as do parts of a fœtus in utero. There is dulness on percussion over its whole surface, except perhaps at the margins where

bowel distended with gas may overlap it, or by contact give a false impression of resonance.

No pain is given by palpation unless strangulation or inflammation of the tumour, or considerable hæmorrhage into it, have occurred. An ovarian tumour is usually dumb, no souffle being audible as it frequently is in all kinds of uterine tumour; but pulsation sounds communicated from the great abdominal vessels may be heard and are of no importance.

The recognition of these features will enable us to exclude all the ordinary conditions simulating abdominal tumours. There is no defined tumour, dull on percussion, produced by accumulation of fat, or by distended flatulent bowels; whilst fæcal masses are more likely to be overlooked than to be mistaken for ovarian tumours: I have already referred to the paramount necessity of clearing the bowels and emptying the bladder before attempting to make a diagnosis.

*Hydroperitoneum (Ascites).* — It is only under exceptional circumstances that a passive hydroperitoneum gives rise to difficulty in diagnosis in relation to ovarian tumours. Hydroperitoneum may be present with any form of abdominal tumour; or if one or more parts of a cystic tumour having burst continue to leak into the peritoneal cavity, a condition of tumour with free fluid may be produced. In such cases the tumour will usually be felt, and the presence of free fluid ascertained with equal certainty.

But the most puzzling and unexpected cases are those in which a passive serous effusion takes place, perhaps to the extent of several pints; and the fluid, instead of sinking to the most dependent parts, is confined to the centre of the abdomen, in a kind of sac formed by the coils of intestine tightly pressed together or slightly adherent. The physical characters of such a collection are not distinguishable from those of a thin-walled unilocular cyst. Two such cases occurred in succession in my own practice, and both were mistaken for ovarian cysts.

Collections of fluid in the peritoneal cavity in connection with chronic tubercular peritonitis, are frequently met with; but as a rule a "tumour" thus formed will be resonant on percussion over a large part of its area, and will be accompanied by other signs of evident illness; the temperature will usually be found distinctly raised at night — a symptom of the highest importance.

The last class of false abdominal tumours are those formed from matted coils of intestine and omentum, with more or less fluid in the interstices, whether serum or pus. Such masses are produced in connection with inflammations of the vermiform appendix, or of the ovaries and oviducts; and these, from their close proximity and frequent adhesion to the uterus, are liable to be mistaken for uterine fibroids.

*Diagnosis of Pelvic Tumours.* — To recognise the presence of a pelvic tumour, and still more to be able to identify its nature, is a far more difficult matter than in the case of most abdominal tumours. It requires not only an intimate knowledge of the subject, but a greater experience

in the practical application of that knowledge than most practitioners are able to obtain. We have here first to deal with the recognition of a tumour.

A pelvic tumour from simple anatomical reasons is most likely to occupy that part of the pelvic cavity which lies above and behind the uterus and broad ligaments. This space, in health, is occupied by coils of small intestine, which are very easily displaced from it; and it varies in size with the varying distension of the bladder and rectum. Normally the utero-vesical pouch is merely a linear cavity, the uterus and broad ligaments resting directly on the bladder. This linear cavity is at once opened up and admits coils of small intestine, when the uterus and broad ligaments are retroverted; and, under such conditions, is of course most open when the bladder is empty. A pelvic tumour can only be recognised in either of these cavities by a bimanual examination; and the emptying of bladder and rectum, and the use of an anæsthetic, are of the greatest importance in this examination, as in the case of abdominal tumours.

A tumour may be so small as not to lead to any appreciable displacement of the uterus; such are the rare tumours of the round ligaments of the uterus, the common small enlargement of the ovaries and tubes, and small uterine fibroids. But as a rule the tumour, according to its position and size, will be found to displace the uterus more or less to the opposite side if lateral to the uterus; forwards if behind it; backwards if in front of it.

The first suspicion of the presence of a pelvic tumour usually arises during a vaginal examination. The cervix is first identified either in a nearly normal position or displaced laterally, anteriorly, posteriorly, upwards or downwards; and careful palpation reveals a convex swelling behind, in front, or on one or on both sides of it. The next stage is to ascertain that the convex swelling is part of the surface of a more or less spherical tumour, not something simulating one. The conditions most likely to simulate a tumour are—(i.) the body of the uterus felt as it normally is through the anterior fornix; or felt more readily than normally because anteflexed or because of an increase of its normal anteversion; or felt on one side of the cervix from lateral displacement; or through the posterior fornix from retroversion or retroflexion: (ii.) the bladder more or less distended, or the rectum loaded with feces: (iii.) some adhesions intra- or extraperitoneal. The diagnosis of the second states is so easily determined by the use of the catheter, and by digital examination of the rectum, that it is not necessary to allude to it further; but adhesions, the result of perimetritis, or parametritis, require careful examination. In the first place, simple adhesions usually draw the uterus to the affected side, and by bimanual examination are found to have little thickness; the two hands may meet, and the absence of a "tumour" is then clear. If there be much effusion of pus, blood, or serum, either into the cellular tissue or peritoneum, a definite tumour is formed and the uterus is displaced from its normal position. If, by a



bimanual examination, the abdominal hand finds a convex surface projecting into or above the pelvic inlet, and corresponding with that discovered by the finger in the vagina, the presence of a "tumour" is then clear; and we proceed to endeavour to ascertain its nature, and in the first place to determine that it is not the body of the uterus enlarged by pregnancy, or by such diseases as produce uniform increase in size — such as certain fibroids, cancer of the body, pyometra, hæmatometra, and hydrometra.

Here, as in the case of abdominal tumours, to set aside pregnancy is of the first importance, a task by no means always easy even to the experienced physician; and it is not rare to find pregnancy at any stage complicated by the presence of a tumour.

The diagnosis of the pathological enlargements of the body of the uterus is given elsewhere, the difficult bimanual examination being of the greatest importance.

If pregnancy is certainly set aside, the uterine sound passed up to the fundus is of the greatest value; for it not only determines the length of the uterine cavity, a detail of great value in distinguishing uterine from non-uterine pelvic and abdominal tumours, but it identifies the relative positions of tumours lying close to it in cases in which a bimanual examination has failed to do so. The difficulties which are met with in passing the sound to the fundus, however, lead sometimes to mistakes in both these particulars, and to incorrect inferences.

Having now excluded or recognised enlargement of the body of the uterus, and determined that there is a tumour adjacent to it, and what their relative positions are, we proceed to consider, one by one, the different forms of tumour that may be present.

The consideration of such tumours shows how necessary it is to have a wide knowledge of the diseases themselves, and of their symptoms and physical characters, as well as a large experience in practical diagnosis, to enable the practitioner to arrive at an accurate conclusion; and every one knows how often the diagnosis, even by men of large experience, is imperfect, or indeed sometimes quite mistaken.

Before proceeding further it will be well to return to abdominal tumours that we may make a preliminary selection of them, as both pelvic and abdominal tumours have many points in common; and the differential diagnosis, when once the tumour is ascertained to have a pelvic origin, proceeds on almost identical lines. Also abdominal tumours can often be felt on vaginal examination to lie partially within the pelvis; even sometimes when they arise from organs so distant as the kidneys and spleen. We must, therefore, bear in mind that while tumours contained in the pelvis are almost invariably of pelvic origin, abdominal tumours which lie entirely above the brim of the pelvis may have originated either in the pelvic or in the abdominal organs; and that tumours that lie partly in the abdomen and partly in the pelvis, while usually of pelvic origin, may have arisen primarily in an abdominal organ, and have descended later into the pelvis.

*Diagnosis of the Site of Origin of an Abdominal Tumour.*—It is not nec-

essary here to discuss all possible sites for every variety of abdominal tumour. We begin with the assumption that the tumour before us is so situated in the abdominal cavity that a pelvic connection is not altogether improbable; thus we exclude at once such tumours as those of the gall-bladder and pylorus. Now such a tumour may arise in the pelvic, renal, splenic, hepatic, and central (mesenteric and omental) regions. A tumour of pelvic origin can be traced down to the pelvic brim, as the physician stands by the side of the patient and looks towards her feet, with his hands placed on her abdomen and his fingers directed downwards to the pelvis; there will be no area of resonance between the prominent part of the abdominal tumour and the pelvic brim, because the tumour, as it arose out of the pelvis, will have displaced the intestine in much the same way as a gravid uterus does, and will lie in contact with the abdominal wall. A small tumour of pelvic origin lying above the pelvic brim is usually very freely movable, and may therefore be found sometimes on one side, at other times on the other; but if it be found constantly on one side, this will indicate with great probability the side from which it sprang.

Large tumours, having to accommodate themselves with greater difficulty to the abdominal cavity, are more centrally placed, and their mobility is much more restricted.

Many tumours arising from the kidneys are easily identified as to their origin. A renal tumour is almost confined to one-half of the abdominal cavity, and it can be traced by bimanual palpation (one hand being on the abdominal surface of the tumour, the other on the loin) right into the region of the kidney.

The only tumours of the liver likely to be mistaken for ovarian are hydatids. They are notoriously deceptive; but as a rule their connection with the liver can be traced, and an area of resonance between the tumour and the pelvis can be detected.

A large fluctuating hydronephrosis, extending well across the middle line of the abdomen and so far down into the cavity of the pelvis that it can be reached by a vaginal examination, may very easily be mistaken for an ovarian cyst.

The spleen may become dislocated and greatly enlarged, and sinking down to the pelvis be mistaken for an ovarian tumour. Mr. Meredith operated on such a case, which he and the writer believed to be a solid ovarian tumour. It occupied the utero-vesical pouch, where it was easily recognised; and it rose nearly to the navel. On opening the abdomen a black mass was exposed, which proved to be the spleen. It was left untouched in this position, the patient being in excellent health. The cause of the dislocation appeared to have been a violent fall from a dog-cart.

Tumours arising in the central abdominal regions are often very puzzling; the presence of a well-defined area of resonant bowel between them and the pelvis, and the absence of any definite connection with the pelvis, though not sufficient for diagnosis, is sufficient to distinguish

them, with rare exceptions, from ovarian tumours. It must be borne in mind, however, that in exceptional cases a tumour of pelvic origin may lose its pelvic attachment, and be fed by the blood-vessels of its omental and other adhesions; or may have such a long pedicle that it becomes entirely abdominal in position.

*Diagnosis of Ovarian and Broad Ligament Tumours from other Pelvic and Abdominal Tumours.*—It has already been pointed out that the diagnosis of ovarian and broad ligament tumours is made by a process of exclusion of other forms of tumour, as well as by the recognition of the physical characters of the tumour under observation; characters which are not always so distinctive as to enable us to do more than arrive at an opinion of probability, but not of certainty: and it not infrequently happens that the complete diagnosis is not made until the tumour has been exposed to sight and touch by an exploratory operation. It is obvious that under these circumstances it is not only necessary to know the varieties, the symptoms, and the physical characters of ovarian and broad ligament tumours, but that it is also of no less importance to know the varieties, the symptoms, and the physical characters of all tumours which may occupy the same region, or be otherwise mistaken for them. It is not desirable within the limits of this article to enter on this part of the subject, but I will refer for the last time to the conditions which too frequently lead to easily preventable mistakes in diagnosis. Of these the most common are a normal pregnancy, a distended bladder, flatulent distension of the bowels, a fat abdominal wall, and, less frequently, simple ascites. Such mistakes are the result of ignorance of first principles, or of carelessness in examination; they are not to be prevented by other means than knowledge, due care, and systematic examination.

*Direct Recognition of the Physical Characters of Uncomplicated Ovarian and Broad Ligament Tumours.*—The large majority of all these tumours are cystic. In the rare cases of solid ovarian tumours the diagnosis practically lies between them and uterine fibroids, either sessile or pedunculated, projecting from the peritoneal surface of the uterus; these are common enough. The direct diagnosis of the presence or absence of uterine fibroids by bimanual examination is not usually difficult. If hydroperitoneum be found complicating a solid tumour of pelvic origin the tumour may be assumed to be ovarian.

Cystic ovarian or broad ligament tumours, when uncomplicated by adhesions or impaction, are easily recognised by their well-defined spherical shape and obvious elasticity; but they have to be distinguished from cystic dilatation of the oviducts, and this is frequently not by any means easy, unless the ovary on the same side can be defined by rectal examination (the uterus, if necessary, being drawn down with an appropriate instrument). The close proximity of the two organs and the great similarity in shape and other characters of the cysts formed in them, make this differential diagnosis often uncertain. The importance of it is, however, of the highest degree if extra-uterine gestation be suspected; for though the possibility of a primary ovarian pregnancy cannot be

denied, experience amply shows that if the tumour can be proved to be ovarian, it may safely be assumed not to be the seat of a gestation sac. Cysts invading the broad ligaments, or originating in them, are more obviously lateral, and displace the uterus as they increase in size; they are also less freely movable, and not rarely, as they grow, they insinuate themselves beneath the peritoneum, beyond the limits of the broad ligaments in the pelvic and abdominal cavities. The essential points, then, in the diagnosis of a pelvic ovarian tumour are the discovery by bimanual examination of a spherical cystic tumour; or, much more rarely, of a solid one, which, although found to lie in close relation to the uterus, is ascertained not to be uterine. It is, of course, in cases where the tumour and the uterus are closely pressed together, or are adherent, that mistakes are so easily made: but the absence of menorrhagia and of lengthening of the uterine cavity should put us on our guard; and the advantage of an examination under an anæsthetic, which completely relaxes the muscles, is very great. After consideration of the preceding details, it will be seen that Matthews Duncan's teaching fairly represents the difficulties of diagnosis:—

“I have said it is a nearly safe rude guess that you have an ovarian dropsy when you find a quickly grown cystic-feeling tumour in the belly of a woman, and this rude diagnosis is nearly safe because of the comparative frequency of ovarian dropsy as the cause of such tumours. . . . Every case demands careful investigation, for a good diagnosis is difficult, or, in other words, errors are frequent.”

*Diagnosis of Strangulation of the Pedicle.*—The symptoms of this complication vary as the arrest of the circulation in the pedicle is sudden or gradual; complete or incomplete.

In the acute cases there is sudden and severe pain in the region of the pedicle, often accompanied by faintness, vomiting, and collapse. The abdomen is tender, and becomes much more so, and is distended by tympanitic bowel as well as by the tumour. Such symptoms occurring in a woman known to have a tumour in the pelvis or abdomen are sufficient indication both for diagnosis and treatment; and the latter should be removal without delay. To wait for the subsidence of the symptoms of peritonitis is usually to wait until it is too late. Day by day, in such a case, the symptoms will be getting more grave; and careful observation of the tumour will often lead to the recognition of an unmistakable increase in size (distinguishable from conditions simulating this, such as adhesions of coils of intestine and inflammatory exudation round it). Such enlargement, noticeable from one day to another, is the result usually of hæmorrhage into the cyst, or sometimes of the rapid formation of pus in it; the differential diagnosis between the two is not at all easy, but it is of no real importance, as the treatment is the same in both cases—immediate removal.

A temperature constantly below the normal is in favour of hæmorrhage; inflammation of the tumour, which usually results from acute strangulation, is attended by some degree of fever.



The success which follows operative treatment in such cases, when correctly diagnosed, marks one of the great advances in abdominal surgery in the last few years. In less acute cases the symptoms arise more gradually; and there is not the imperative need for immediate removal: yet removal without undue delay is the best treatment, for adhesions, when recent, can be separated without difficulty; but when they become fibrous and tough great difficulties may be incurred in the separation, and great injury may be done to important viscera, especially to the intestines, which may lead to serious complications after the patient's recovery.

Adhesions of the omentum, even when extensive, are surgically of little importance. A curious condition of varicose vessels in the omentum is sometimes met with resembling a bundle of worms, lying immediately beneath the abdominal wall, on the surface of the tumour.

**INFLAMMATION OF THE OVARIES.** — It is necessary to bear in mind that inflammation of the ovaries is intimately associated with and usually forms one part of a widely extended inflammatory process involving the uterus, the oviducts, and the pelvic peritoneum and cellular tissue; and that to describe apart the inflammation of any one of these structures is likely to lead to narrow and erroneous views, not in pathology only but also in diagnosis and treatment.

Inflammation of the ovaries may fairly be described as occurring in two forms, which are frequently though not necessarily combined; namely, inflammation of the surface (perioophoritis), and inflammation of the organ itself (oophoritis).

**Perioophoritis**, resulting in adhesions to adjacent parts, is commonly met with. It is a more or less important part of that disease — great in importance and frequency, though often slight in severity — which is known as perimetritis (that is, the pelvic peritonitis of women).

The adhesions may be mere threads uniting the ovary to the omentum or other adjacent parts; or a glueing of part of its surface to the mouth of the oviduct; or they may be so extensive as to lead to some difficulty in finding and disembedding the ovary in the course of an operation or post-mortem examination. Perioophoritis may arise as an extension of oophoritis, but this is probably not the most frequent course: it is more commonly part of a perimetritis arising by infection of the pelvic peritoneum through the open mouth of the oviduct, or through lymph channels or wounds communicating with the peritoneal sac; or again, the result of an effusion of blood into the peritoneal cavity (hæmatocele).

In some cases the disease may not be of pelvic origin, but only part of a general peritonitis of septic or tubercular origin. Perioophoritis has already been referred to as a complication of ovarian tumours.

The disease perimetritis is described in the article on "Pelvic Inflammation"; here I have only to indicate certain points which affect the functions of the ovary and the health of the individual.

The chief function of the ovary, apart from any supposed "internal secretion," is to provide a sight for the maintenance and perfect development of healthy ova, to allow their extrusion under certain not well

ascertained conditions, and to discharge them in a position where they may securely find entry into the mouth of the oviduct. It is obvious, on the other hand, that perioophoritis will be likely to interfere with the extrusion of the ovum and its passage into the oviduct. For, in the first place, it is accompanied by a thickening and induration of the surface of the ovary, which interfere with or prevent the rupture of the Graafian follicles. Thus it is probable that the rupture may be prevented by the close adherence of that part of the ovary which contains the follicle to some neighbouring structure. Or the ovum, having been extruded, may be prevented from passing into the oviduct by adhesions fixing the fimbriated orifice to another part of the ovary.

Adhesions are a fertile source of suffering, especially if they restrict the free mobility of the ovary, and fix it in a position where it is subject to undue pressure. The patient probably suffers pain, localised more or less distinctly at the pelvic brim, and extending down the thigh of the affected side. Also during the days preceding and at the commencement of the menstrual flow, a tender, fixed ovary becomes far more tender owing to its vascular engorgement at this time, and perhaps to the further increased tension of the organ already confined by adhesions.

It is believed by many authors that an inflammation beginning as a perioophoritis may extend beyond the surface into the substance of the ovary, and produce induration and other changes in the superficial stroma, which may lead to dropsy of the follicles and to hæmorrhage with consequent degeneration of the ova. Such a condition is known as "cystic ovaritis." Examination of some enlarged ovaries affected with oophoritis certainly appears to favour the view that fibrosis may arise on the surface and gradually invade the deeper tissues; but before we can feel sure of the interpretation of the details observed, we must attain an accurate knowledge of the normal ovarian structure at different periods of adult life.

**Oophoritis**, in its well-marked forms, like perioophoritis, is part of a more general disease. Even where there are no signs of inflammation of contiguous structures, and where this appears to be the single disease from which the patient is suffering, evidence can often be obtained that it arose in connection with some such disease as gonorrhœa; or there may be evidence of tubercle elsewhere; or again, it may be the only important relic of an extensive septic inflammation.

Oophoritis in its most acute forms is met with in connection with acute pelvic or general septic inflammation — the infection having gained admittance through lesions of the vagina and uterus arising during labour, abortion, surgical operation, or examination or accidental injury of the parts. If the ovary were previously the seat of cystic disease, or of tubercle, it may become further infected and inflamed by the passage of septic organisms from the bowel through the cyst wall.

The continuity of structure of the stroma and the blood and lymph-vessels, of the ovaries and broad ligaments, readily explains the extension of inflammation of the vagina or uterus along the parametric connective

tissue to the ovary. This no doubt occurs; probably it is the most frequent course; but in many cases such an extension cannot be traced.

It is commonly held that oophoritis is the result of an extension of inflammation from the uterus along the oviduct, the infective material escaping from the open mouth of the tube on the surface of the ovary. This supposition does explain the occurrence of perioophoritis; it is well known that escape of pus from a pyosalpinx does produce a localised or general peritonitis; and it may be the fact that septic matter may gain access to the interior of the ovary through an open and ruptured Graafian follicle, if not through the lymph spaces on the surface. Wertheim's (36) investigations appear to prove conclusively that gonococci may pass directly through the wall of the Fallopian tube into the substance of an adherent ovary, or into the broad ligament, and so set up inflammation.

The most acute forms of oophoritis are those resulting from septic infection in connection with child-birth, abortion, and surgical procedures. In the fatal cases the ovary may be much enlarged, soft, and sloughing; or in less severe cases small extravasations of blood or pus may be seen on section in the stroma or follicles; in either case the uterus, oviducts, and broad ligament will be found in a condition similar to that of the ovary. In cases where death has occurred within a few days of the infection, little loculi of pus can often be found in the vessels and connective tissue, close to the side of the uterus as well as in the uterine walls; and the mucous membrane of the oviducts will be found acutely inflamed. Evidence of a wide-spread septic process is also to be found in more distant structures.

In cases of acute but localised septic oophoritis the early changes are less certainly known; though, as a result of the surgical procedure now often successfully adopted, the later stages are becoming more familiar to us. The minute foci of suppuration either disappear by resolution, or they extend and coalesce, and may form an abscess of considerable size—the size of a hen's egg or larger. The very large abscesses of the ovary are probably the result of suppuration of cysts. Such suppurating ovaries become adherent to neighbouring structures, and if the walls are very thick the abscess may remain quiescent; nevertheless it may produce a chronic state of ill-health and suffering, or it may open into the bowel; indeed, unless it be thus emptied and the cavity enabled to shrink up and ultimately to close, the patient passes into the same state of chronic ill-health as that produced by an unruptured abscess, and under such circumstances, unless the patient can be relieved by operation, she may gradually lose ground and finally die from exhaustion and the other consequences of prolonged suppuration.

**Oophoritis Serosa.**—There is quite another form of what may be called inflammation of the ovary of an exceedingly chronic kind—chronic in development, very chronic in duration, but in the majority of cases curable under proper management. It is met with in cases of prolonged ill-health in which no local cause can be recognised. It follows

some fevers, it has occurred in two cases of mumps under my own care, it is met with in women married for some years who have not become pregnant: in some of these cases the cause of the sterility may be a passive gonorrhœal infection; indeed, this form of oophoritis appears to be that most frequently produced by gonorrhœa, and in some cases it is accompanied by definite salpingitis and perimetritis.

Clinically the ovaries are found to be swollen, very tender, and often prolapsed; such ovaries have frequently been removed by surgeons. They present a swollen, congested appearance in the earlier stages; in advanced cases they are extremely swollen, smooth, shiny, and almost translucent, the folds and cicatrices being sometimes quite obliterated. On section this appearance is seen to be due to œdema and probably consequent anæmia of the whole organ. This condition in various degrees of severity is one of those most frequently found in cases of so-called chronic oophoritis. It is often called œdema of the ovary, but better, by Olshausen and others, "oophoritis serosa."

In very many cases it is not possible, indeed it may be hardly necessary, to attempt to distinguish cases of parenchymatous from those of interstitial oophoritis. In the acute septic forms the follicles, stroma, and vessels are alike affected; but in the chronic forms there are undoubtedly different degrees of affection of the stroma and follicles. In the cases of simple œdema, or phlegmon, it is the stroma that shows the most marked changes; while in chronic interstitial oophoritis, a condition which passes by insensible gradations into the various forms of fibroma ovarii, both structures are affected, though to a varying degree, in different cases. In some the ovary is enlarged, by a marked increase in bulk of the stroma, to three or four times its natural size; in others the distended follicles are visible over the whole surface: it will be noted that there is no tendency to proliferation of these little cysts.

All authorities, however, following Olshausen, describe these states as constituting definite varieties; and many attempt a more minute classification: but to give distinctive names to every little variation, such as is produced by a slight additional extravasation of blood, seems more likely to confuse than to advance pathology. And classification is further complicated when authors describe as oophoritis cases in which the only evidence of such a condition is the presence of one important clinical symptom, the so-called "ovarian pain," or, as it should be described, pain referred to the region of the ovary.

The name "cirrhosis" is applied to various conditions of the ovary, about which, in the absence of precise knowledge, there is no general agreement. Some apply this name to conditions almost physiological; for instance, to ovaries shrunken and shrivelled by an atrophy, sometimes perhaps prematurely senile; others to conditions of the ovary, the only abnormality of which is an unusual degree of cicatricial fissuring of the surface, — the result in some cases, undoubtedly, of an early developmental variation, but apparently much more often the result of active ovulation; while others again, with greater propriety, restrict the term



to the minor degrees of fibrosis with more or less dilatation of the Graafian follicles.

**Tubercular oophoritis** should be considered not only in relation to tubercle of the other genital organs, but in relation to tuberculosis in general; for, as I have shown in a communication to the Pathological Society of London (10), the ovary is one of the least common seats of tubercle, and when tuberculous, it is almost invariably in association with tubercle elsewhere; as for instance in the lungs, lymph glands, meninges of the brain, peritoneum, oviducts, and uterus.

Tubercle is found to affect the ovary in two distinct forms: (a) miliary tubercle of the surface, usually, but not invariably, associated with tubercle of the peritoneum and leading to tubercular perioophoritis; (b) miliary tubercle in the substance of the ovary, which, undergoing caseation, usually suppurates, and eventually leads to abscess.

In the first class of cases the ovary may be of normal size, or may be the seat of cystic or other disease. There are no special symptoms, and the disease is only recognised on inspection of the ovary during operation or after death.

In the second variety the later stages of abscess are now well known; the diagnosis of the tubercular origin of the disease is, however, a matter of surmise until the ovary is itself examined after removal. Its size and physical characters naturally depend, not only on the extent of the tuberculous disease, but on the degree of suppuration. In this form of disease caseous masses will often be found in the abscess cavities, and miliary or caseating tubercles in other parts of the organ. The earlier stages of the second variety are not rarely met with, and the gross physical characters need further investigation; very few specimens have been fully described (4).

The ovary is found to be enlarged, even perhaps to the size of a small apple, without suppuration; though it is not by any means certain whether this enlargement be due solely to the tubercular affection. Even if there be no caseation, and the bacilli, as usual in this form, very few and hard to find, the microscope, by revealing the histological characters of tubercle, will place the diagnosis beyond doubt.

The variety described by Whitridge Williams (37), in his valuable paper under the name of "Unsuspected Genital Tuberculosis," does not seem to deserve to be raised into a special class. We may reasonably expect that as our knowledge of this affection increases the cases included in this particular variety will become rarer.

Hegar, Olshausen, and Whitridge Williams discuss the possible mode by which tubercular infection of the female genital organs can take place, but there seems no reason to suppose that, with the possible exception of infection by semen, the manner of infection of these organs differs from that of other parts. The age of the youngest patient recorded in the author's paper was five years, the oldest fifty-five; five were under fourteen years, eight were between fourteen and twenty-five, three between twenty-five and forty-five, and one was fifty-five.

The ovary ranks third in the order of frequency with which the female organs are affected with tubercle; the oviducts and mucous membrane of the body of the uterus being first and second respectively.

The question of oophorectomy in a case in which the disease of one ovary is suspected to be tubercular in origin, is one of comparatively easy solution; as in such cases the disease will lead in the majority of instances to suppuration, and the treatment will be determined on general surgical principles. And if there is a strong probability of the presence of tubercular disease in the ovary, and a marked absence of evidence of it from other organs, there can be little doubt that the most conservative treatment is the removal of the affected parts by a complete operation. The oviducts will almost invariably have to be removed at the same time.

*The symptoms* of oophoritis are by no means easily distinguishable from those due to inflammation of other pelvic viscera, which, indeed, is usually present at the same time. In cases of acute septic poisoning, with the most active destruction of the ovary, we know of no symptoms significant of the ovarian lesion; the disease is septicæmia, and we do not attempt to analyse the symptoms or to recognise the manifestations of the disease in an organ so unimportant to life.

It is in the less severe inflammations that we are able to recognise symptoms with distinguishing characters, and in some of them by physical examination to diagnose the lesser forms of oophoritis. All forms of oophoritis are so intimately associated with inflammation of the oviducts and the surrounding peritoneum, that in the present state of our knowledge I can only describe the general symptoms.

Pain is the one constant symptom of all varieties of pelvic inflammation, and the site to which it is referred by the patient bears no constant relation to the organ affected. The whole region below the navel and above the pelvic brim, from the pubes to the iliac spines, back to the loins and sacrum, and down the thighs to the knees, is or may be the seat of pain in various circumstances; but we have no trustworthy means by which we can distinguish one-sided pains due to affections of the tube, ovary, peritoneum, broad ligament, or the body of the uterus or the cervix.

Those who have read Dr. Head's valuable work on localisation of pain due to visceral disease (11), may be disappointed that greater practical results have not as yet followed in this and in some other regions of the body from his investigations, which are of the highest value, and which must in time lead to very important results. The reasons in this case are obvious; the four areas localised by him, namely, 10th, 11th, and 12th dorsal, and 1st lumbar, are common in different degrees to the ovary, tube, and body of the uterus; and further investigation is necessary to enable us to distinguish disease confined to one of these organs: indeed, the common diseases causing pain most frequently affect all these parts.

The pain is aggravated, as are all pains due to inflammation, by any increase of pressure on or within the ovary. The most important cause of increased tension within is the premenstrual and menstrual vascular congestion, which will set up severe pain at this time. The pain is easily

distinguished from that called true dysmenorrhœa, by the fact that it is the aggravation of a pain which continues between the periods; while true dysmenorrhœa is a purely menstrual pain. There are, apparently, exceptions to the rule of menstrual increase of pain, for we meet sometimes with patients who say that the only time they are free from pain is during the menstrual flow.

The pain that persists after coitus may also be due in some cases to congestive tension.

The most constant source of pain from pressure is the general intra-abdominal pressure of the various viscera on each other, increased by all straining efforts even of a comparatively slight kind. Such pain is relieved gradually by the horizontal position; some patients spontaneously lie on the back, others on the chest or side.

Pain is also caused by direct pressure on the organs through the abdominal walls, the vagina, or rectum; as for instance during a medical examination, or coitus, or the passage of large fœcal masses.

Of the other great symptoms of pelvic disorder, hæmorrhages, menstrual or intermenstrual, amenorrhœa, and leucorrhœa, none is known to be characteristic of oophoritis. The presence or absence of any one of them probably depends largely on the extent of the inflammation of the uterus itself, and on the general state of the patient's health.

Reference must not be omitted to the wide distribution of neurotic symptoms frequently met with in women suffering from various pelvic ailments, amongst them ovarian. To discuss this subject adequately would require a space beyond that allotted to me, but it may safely be said (*a*) that the local pelvic lesion is most frequently a minor one; (*b*) that different authors attribute these symptoms to lesions of various organs, the commonest lesions being oophoritis, displacements of the uterus, and fissures of the cervix; (*c*) that the symptoms are not generally met with in women of robust minds, who suffer from the same very common local lesions; (*d*) that the nerve symptoms have a great tendency to persist after the cure of the local lesion; (*e*) and that the greatest benefit is obtained by attention to the principles of general treatment, that is, by a treatment tending to restore and increase the vigour of the mind in a more vigorous body — a restoration, however, by no means always practicable. Such cases form a great source of gain to all kinds of quack practitioners; and while some of them are cases of great and permanent success and satisfaction to the rational and honourable practitioner, many are a continual source of disappointment to all whose misfortune it is to be their relatives or medical advisers.

*Diagnosis* of oophoritis can be made in some cases with practical certainty, when the finger in the rectum, or less frequently in the vagina, recognises a tender body of the shape of the healthy organ, but somewhat larger, lying to one side of or behind the uterus and broad ligament.

Fixation by adhesions interferes with this ready recognition, and unless special means be adopted to make the examination under the most favourable circumstances, there will constantly be doubt as to how

much of the swelling is ovary, how much tube, and how much adhesions and surrounding effusion.

The most favourable conditions for examination of a difficult case are an absence of obesity, the influence of an anæsthetic, the lithotomy position, the evacuation of the rectum and bladder, and the drawing down of the uterus by a suitable instrument. Even with these advantages it is not surprising that we are foiled at times in our search for precise knowledge; while in some cases, even after removal of the organs, there is great doubt how much is ovary and how much tube. And when we do succeed, our success is more a source of satisfaction to our pride than a benefit to our patient, whose treatment, whether by operation or by a prolonged course of medical means, is not materially affected by the seat of the disease, whether it be in ovary or tube; the essential thing is the diagnosis of the presence of inflammation, its degree, its duration, and its effects.

*Treatment.*—The general principles which govern the treatment of inflamed ovaries are common to all cases of pelvic inflammation; and the most valuable, namely, rest in bed, may easily be carried too far, especially in the slighter cases; great care is also needed in watching the patient to observe the effects of this treatment on the general health, as well as on the local condition; in order that the physician may be enabled to put a proper term to it. And the same close attention must be paid to the effects of drugs for the relief of pain. Acute pain must be relieved: to this end hot applications to the hypogastric region are effectual, and hot vaginal injections also, though to a less extent; more direct relief will, in some cases, have to be afforded by such drugs as opium. In the protracted cases the application of heat will soon lose its good effects; anodynes will not only fail likewise, but will become a positive source of danger to the patient: if the suffering is genuine and severe, and not out of all proportion to the ascertained lesions, removal of the inflamed organ by operation will have to be considered, and probably adopted. But in cases where the lesions are small and the nerve symptoms great, the treatment should be radically different; we should endeavour in every way to improve the general health, and neglect the local disorder as far as possible.

**HÆMATOMA OF THE OVARY.**—Extravasation of blood into the ovary is not rare, but our knowledge of the condition is certainly not very precise.

It is easily recognisable in three forms: hæmorrhage into the stroma; into Graafian follicles; and into cysts, such as cystic follicles, cysts of the corpora lutea, and large proliferating cysts. Hæmorrhage into cysts from strangulation of the pedicle, or from rupture of the vessels in the very vascular papillary or glandular masses in their walls, has already been described, page 850.

Cysts of the corpus luteum are small and commonly filled with blood, the result probably of degeneration of the walls and consequent rupture of some vessels.



Minute hæmorrhage into the stroma or follicles is also not very rare, and appears to have some connection with conditions where there is considerable and persistent uterine hæmorrhage.

Such hæmorrhages into the stroma occur also in acute septic oophoritis, and during menstruation, apparently normal, into the follicles; Winckel found them in cases of heart disease, typhus fever, phosphorus poisoning, and in three cases of extensive burns.

Sometimes the hæmorrhage into the stroma appears to be secondary, the result of a ruptured follicle distended with blood. Hæmorrhage into the ovary, apart from hæmorrhage into cysts, is of importance because of its effects in increasing the size and weight of the ovaries, and thus becoming the cause of pain and prolapse. It is probable that in slight degrees it may be a more frequent cause of painful and tender ovaries than is generally supposed.

We have no means of diagnosing this condition; we recognise it merely as a pathological phenomenon.

**PROLAPSE OF THE OVARY.** — The position of the ovaries in a healthy woman, lying as they do loosely attached to the superior surfaces of the broad ligaments (these being more nearly horizontal than vertical in the erect position) and to the sides of the uterus, admits readily of their descent on the utero-sacral folds, or farther into Douglas' pouch, if the normal conditions of their support are disturbed. The abnormal conditions producing this prolapse are an increase in weight of the ovaries, and prolapse, retroversion, or retroflexion of the uterus and broad ligaments.

The actual prolapse may be sudden, the result of a strain; more often it takes place gradually.

Prolapse of the ovaries is, therefore, only one phenomenon complicating various disorders of the pelvic organs; but it deserves special attention from the frequency of its occurrence, and from the important symptoms to which it may give rise: for it not unfrequently happens that the symptoms due to the prolapse are the only important symptoms present.

Prolapsed ovaries may become fixed in their abnormal position by adhesions; a serious complication, as it renders relief almost impossible except by means of operation.

The conditions of the ovary which cause its enlargement are described elsewhere: these are simple œdema, inflammation, tubercle, hæmatoma, and incipient tumour formation. Displacements of the uterus are also dealt with elsewhere in this *System*.

I have here only to describe the symptoms, diagnosis, and treatment of the prolapse.

*Symptoms.* — Prolapse of an ovary is a displacement of a sensitive organ from a position of free mobility and of security from violent pressure (namely, between the elastic bowels and broad ligaments) to a position in which its mobility is very much restricted (especially if both ovaries are prolapsed into Douglas' pouch), and where it is very liable to be squeezed by the surrounding parts as the result of general intra-

abdominal pressure, varying with muscular exertion and with the distension of bowels and bladder. These changes cause more or less constant aching, and the pain is increased as the menstrual congestion recurs. Furthermore, the organs are liable to special pressure during coitus, and during the passage of large or hard fæcal masses through the rectum—both of which disturbances cause sudden and severe paroxysms of pain.

A prolapsed ovary is usually swollen, and is more sensitive to pressure than in its natural position; but it is not easy to say whether these changes are due to the prolapse or not. The conditions under which prolapse occurs are such as would usually cause swelling, and consequently increased sensitiveness of the organs.

*Diagnosis.*—This is comparatively easy in the case of simple prolapsed, non-adherent ovaries; a movable, sensitive, often very tender swelling of the shape of the healthy ovary, but usually of a somewhat larger size, is found lying behind the uterus and (if completely prolapsed, behind the upper inch of the vagina) in front of the rectum.

When there are adhesions it is often not at all easy to distinguish the ovary from the prolapsed distended extremity of the oviduct.

*The treatment* of prolapsed ovaries is always a very troublesome matter; in itself it is a minor disease, but unless relieved, it may be a source of continual and great suffering to the patient until the climacteric is well passed.

If the prolapsed ovary be movable and not greatly enlarged, and particularly if the uterus is retroverted, retroflexed, or prolapsed, relief can be given by carefully replacing the uterus, and supporting it and the broad ligaments, and, therefore, to a certain extent the ovaries, by a suitable pessary of the "Hodge" type; or, if that cannot be borne, by an india-rubber ring. The patient in such cases should never be kept lying on her back. So long as rest is necessary she should lie in such a way that the tendency to prolapse of the ovaries is the least, and this will be on the chest or in the semiprone position. This method, combined with attention to the general health, is usually successful.

When the prolapsed ovary is adherent, and proper treatment fails within a reasonable time to get rid of the adhesions, and allow the ovary to return to its natural position, great relief can be given by an operation through the vagina or abdominal wall, having as its object the release of the fixed ovary from its prolapsed position, saving it, if possible, and, if necessary, fixing it higher up where the pressure effects are far less likely to be injurious.

The operation through the vagina—*anterior colpotomy*—is destined, perhaps, to take the place of the abdominal operation in the majority of cases, when further experience has enabled us to select the proper cases with certainty; the operation is one of less immediate risk than abdominal section, and it is free from the risk of the subsequent formation of a ventral hernia.

We know of no drugs which have any direct effect on the structure or

functions of the ovary; its minor diseases are best treated by general means, such as fresh air, exercise, proper food, daily evacuation of the bowels, and tonics; with avoidance of injurious pursuits and occupations. Ovarian pain, in the absence of severe lesions, will be most readily and permanently relieved by such measures.

**HERNIA OF THE OVARY.** — This is a rare form of displacement of the ovary, but the condition is one of considerable practical importance. It may be congenital or acquired; when congenital it is associated with persistence of the canal of Nuck, into which the ovary descends; when acquired it is usually inguinal in position: cases are recorded, however, in which the ovary has passed out of the pelvis through the crural canal (femoral hernia), the great sacro-sciatic notch (gluteal hernia), the umbilicus (umbilical hernia), or the linea alba (ventral hernia). The condition may be single or double.

The greater number of cases occur in early youth, but not all of these are congenital. Mr. Bland Sutton rightly emphasises the importance of extreme caution in diagnosing this condition in little girls. In the well-known case recorded in the Obstetrical Society's *Transactions* by Chambers, the supposed ovaries turned out on microscopic examination to be testes; and it is well established that in some hermaphrodites a well-developed uterus and external genitals may coexist with testes [*vide art. on "Malformations"*]. This fact illustrates the necessity of a microscopic examination of the bodies removed in all cases of supposed ovarian hernia in childhood. At this period the condition seldom gives rise to trouble, but occasionally the ovary becomes strangulated and has to be removed.

*Symptoms.* — Some cases remain undiscovered until puberty, when the ovary forms a firm, almond-shaped, generally movable body in the groin or the labium majus, and is liable to be mistaken for a lymphatic gland or a labial tumour. At the menstrual periods the body is stated to become enlarged, painful, and tender. Sometimes it gives rise to continual pain, and the patient thereby becomes a chronic invalid. The condition is no hindrance to conception, and during pregnancy the ovary may increase greatly in size and become very painful; this appears to result when the displaced ovary is the seat of the corpus luteum of pregnancy. In such cases abortion is apt to occur. Occasionally a herniated ovary becomes drawn up into the abdomen during pregnancy, by the expansion and rise of the fundus; but it reappears after confinement, unless a radical cure be, as it should be, effected by operation.

The displaced ovary is sometimes accompanied by the Fallopian tube, and more rarely by the uterus itself, or one horn of a double uterus. Sometimes it appears to be drawn into the sac by adhesion to a knuckle of bowel or piece of omentum. Frequently the ovary becomes cystic, or otherwise diseased; and a case of a gluteal cyst is mentioned by Boinet which was found on removal to be ovarian in origin.

*The diagnosis* must in all cases be tentative until verified by microscopic examination. When the hernia is irreducible and gives

rise to considerable trouble, there can be no doubt of the propriety of surgical interference.

W. S. A. GRIFFITH.

#### REFERENCES

1. AMANN. "Ueber Ovarialsarkome," *Archiv für Gyn.* 1894, p. 484.—2. AUTENREICH. *Archiv für Physiol.* Halle, vol. vii. p. 261.—3. BOINET. *Maladies des oaires*, p. 73.—4. CHAMBERS. *Trans. Obst. Soc. Lond.* vol. xxi. 269.—5. DORAN. *Tumours of the Ovary*, 1884.—6. EDMUNDS. *Trans. Path. Soc. Lond.* vol. xl. p. 210.—7. FISCHEL. *Archiv für Gyn.* Bd. xv. p. 198.—8. FLAISCHLER. "Zur Lehre der Entwicklung der papillare Cysto." *Zeit. für Geb. und Gyn.* Bd. vi. 231.—9. FREUND. *Arch. für Gyn.* June 4, 1892.—10. GRIFFITH. *Trans. Path. Soc. Lond.* vol. xl. p. 212; *Trans. Obst. Soc. Lond.* 1891, p. 140.—11. HEAD. *Brain*, vol. xvi. 1893.—12. HEGAR. *Die Entstehung u. der Genitaltuberkulose des Weibes.* Stuttgart, 1886.—13. JONES, DIXON. *N. Y. Med. Journ.* May 1890.—14. KLEBS. "Beitrag zur Kenntniss der Ovariectomie und der Ovarialgeschwülste," *Virchow's Archiv*, Bd. xlix. p. 298.—15. KLOB. *Handbuch der pathologischen Anatomie.*—16. KOLAEZEK. *Virchow's Archiv*, Bd. lxxv. p. 399.—17. LANDERER. *Zeit. f. Geb. und Gyn.* Bd. xxxi. 1895.—18. LEOPOLD. "Die soliden Eierstocksgeschwülste," *Archiv für Gyn.* Bd. vi. p. 189.—19. MARCHAND. *Beiträge zur Kenntniss der Ovarialtumoren*, 1879.—20. OLSHAUSEN. *Die Krankheiten der Ovarien*, 1886.—21. PFANNENSTIEL. *Zeit. f. Geb. und Gyn.* Bd. xxviii. p. 349; *Archiv für Gyn.* Bd. xl. p. 363.—22. RINDFLEISCH. *Handbuch der pathologischen Anatomie.*—23. ROKITANSKY. "Ueber die Cysto." *Denkschrift der Akad. a Wissen. zu Wien.* 1849.—24. ROSTHOM, VON. *Archiv f. Gyn.* Bd. xli. p. 318.—25. SCHULTZE. *Zeitschrift der Gesell. für Geb. und Gyn.* Berlin, 1894, p. 841.—26. SHATTOCK. *Trans. Path. Soc. Lond.* 1889, p. 208.—27. SIMPSON. *Obstet. Trans. Edinb.* 1893-4, p. 162.—28. SINETY, DE, and MALASSEY. *Compt. rend. de la Soc. de Biol. de Paris*, 1876.—29. SPIEGELBERG. *Monats. für Geburtskunde*, Bd. xxx. p. 380.—30. STEFFECK. *Zeit. für Geb. und Gyn.* 1894, p. 147.—31. SUTTON. *Diseases of Ovaries and Fallopian Tubes*, 1896.—32. THORNTON. *Trans. Obst. Soc. Lond.* 1882, p. 80.—33. VELITS, VON. *Virchow's Archiv*, Bd. cvii. p. 805.—34. VIRCHOW. "Ueber chron. Affect. des Uterus und der Eierstocke," *Wiener med. Woch.* 1856.—35. WALDEYER. *Eierstock und Ei.* 1870.—36. WERTHEIM. *Arch. für Gyn.* Bd. xlii.—37. WILLIAMS, WHITRIDGE. *Johns Hopkins Hospital Reports*, vol. iii. 1893.—38. WINCKEL. *Pathologie der weiblichen Sexualorgane*, 1881. Leipzig.

W. S. A. G.

---

### OVARIOTOMY

OVARIOTOMY is the term applied to the operation of removal of tumours of the ovary. It has also, and conveniently, been made to include operations for removal of growths in the paroophoron, the parovarium, and the broad ligaments; this practice will be followed here. The general description of the operation will be given for the most common and best known variety of ovarian tumour, the glandular cystoma; variations in the proceeding will be described for solid growths; for dermoid tumours; and for growths, simple and papillomatous, which open up the layers of the broad ligaments.

Ovariectomy holds the proudest of positions amongst major surgical operations. It cures a certainly fatal disease without leaving deformity and without chance of recurrence; and this with a risk to life which is



less than in any other major operation. It is a supreme test of skill in the surgical art. Imperfect art or science, bad surroundings or nursing, will as certainly be followed by disasters, as the opposite will be followed by success. Thanks to those who have gone before us, we have inherited a code of rules for the performance of ovariectomy which are probably more complete than for any other operation; the man who knows these, and who has helped to apply them, will have success in his work. Nothing can replace personal knowledge and experience. It is not enough to know everything that has been written, nor even to have assisted at many operations; the best operator must have both advantages. The very success of the operation has been its curse. The man of the old régime who considers that the mortality of a given operation is measured by the ability of the man who has passed his examinations and nothing more, will soon find his mistake here. The highest success in ovariectomy follows the highest training in art, and the most thorough education in science.

It has been one of the pleasing features of the history of the operation, that its introduction was due to the genius of men who sought rather to save lives of patients than to increase their reputation or even to advance surgery. The scientific disquisitions of men like Willius, Delaporte, Morand, Hunter, Chambon, Bell, and others had their influence; it remained for the keenly anxious practitioner seeking only the salvation of his patient to put them into practice. Ephraim McDowell, settled in the backwoods of America, was in 1809 the first of these, thanks to his Edinburgh teaching; Jeaffreson and King, both village practitioners in England, followed. Clay of Manchester took up the thread of success; then, in the hands of Wells in London, Keith in Edinburgh, and Tait in Birmingham, it was successfully established in the large towns as a great life-saving operation. Increase of success has followed the knowledge which these masters have bequeathed in technique, and Lister has introduced in science. At the present day it may be truly said that ovariectomy has scarcely any legitimate mortality. The cases that die are the neglected ones—those which have not been diagnosed till far advanced; those in which accidental complications have been permitted; and those which have been repeatedly tapped.

The actual death-rate of all ovariectomy operations is not easily got at; probably it is still over ten per cent. In the hands of surgeons of the greatest skill and experience it is about five per cent. Successful series of a hundred cases and over have been secured by several surgeons—by myself amongst the number. In the last fifteen years, at least half a dozen surgeons in Great Britain, each with cases reckoned by hundreds, can speak of a general mortality in ovariectomy scarcely exceeding four per cent.

**Preparatory Measures.**—Before the performance of ovariectomy attention is given to the perfecting of the operative environment, and to the preparation of the patient for operation.

Measures, special to ovariectomy in respect to operating room and furniture, the arrangement of assistants, the provision of instruments, and so forth, are to be discussed here.

*Operating Room.*—For ovariectomy no special operating room is essential. It has been abundantly proved that the operation may be performed with as great success in the general operating room of a large hospital, or in a bedroom of a private dwelling, as in special rooms elaborately fitted for the purpose. If the operating theatre is kept as it should be for operations in general, it is suitable for the performance of ovariectomy. A specially prepared theatre is a luxury rather than a necessity—a saving of trouble in preparing for and doing of the operation rather than an addition to its safety. Still the technique is easier, and therefore more perfect in convenient circumstances; and every surgeon would desire to perform ovariectomy in a room specially prepared for the purpose, with all the accessories that the science and art of antiseptics have introduced, and all the aids which experience in the operation has suggested.

In private the operation is usually done in the room which the patient is to occupy during convalescence. A large sunny room which can be easily ventilated should be selected. A bedroom in the clean and wholesome condition usually found in houses of the upper and middle classes in these islands requires little to be done to it. If it be deemed advisable to remove carpets or curtains, this should be done at least two clear days before operation, so that the germ-laden dust may have time to settle. For ventilation a fire in an open grate should be kept burning, even in warm weather. A narrow bedstead with spring and horse-hair mattress should be used. After the first few days the use of two beds, one for the day and another for the night, may add to the patient's comfort. A large folding screen which will shield the patient from glare without darkening the room may be useful.

*Operating Table.*—Many operating tables especially suitable for ovariectomy have been devised. A simple deal board on trestles does perfectly well. For private work a portable table such as that of Mr. Bowreman Jessett is convenient. For hospital work a more elaborate table is desirable. I have designed a table made of plated steel-tubing and glass, which can at once be raised to any height, and made suitable for the Trendelenburg, or any other posture. A reservoir, hung under the table well away from the surgeon's feet and legs, collects ovarian or other fluids. A shoot from the side of the table conducts the fluids into this receptacle from the mackintosh overlying the patient.

The patient's limbs should be confined during operation, and provision should be made for this. In the operating table described this is managed by a broad strap of webbing passing over the knees, and by wristlets which hold the patient's arms under the table. But a piece of strong webbing tied over the knees and under the table for the patient's legs, and a strong bandage fixed round her wrists under the table, do perfectly well.

The table is covered either with a special sterilised mattress or a

folded blanket. For certain cases it is necessary to adopt measures for the application of artificial heat, and some device for this purpose should be provided with every operating table. Large copper or aluminium reservoirs filled with hot water, and placed under the patient or under the table, are sometimes used; such vessels, made to fit the table, can easily be applied under the glass of the table described. If long tubing is attached to entrance and exit taps, the water can be replaced by fresh hot water during the operation, without disturbing the operator or assistants. Hot-water bottles of rubber laid around the patient's body, and between and by the sides of her thighs, serve the purpose very well. For the majority of cases no special application of artificial heat is necessary.

*Coverings of Patient.*—The best clothing for the patient during operation is a single combination suit, completely enveloping limbs and body, and open down the front of the abdomen. Such suits made of several layers of fine flannel, or of fine cotton quilted with cotton wool, may be sterilised completely without injuring their fabric. If such a suit be not available, thick woollen drawers and stockings, and a thick woollen jacket, are quite suitable. If there be any special need for it, additional security against loss of body warmth is got by packing cotton wool under the drawers and jacket, or rolling it round the limbs, and securing it with a bandage. For ordinary hospital work, two thick blankets sewed together and cut at the sides like a many-tailed bandage may be used as a wrap for the patient during operation. To expose the seat of operation two of the flaps are folded back, one on each side; the rest of the body remaining covered.

Over all is laid a large sheet of mackintosh cloth, in which an oval hole has been cut large enough freely to expose the field of operation. An opening four inches broad and eight inches long is large enough for most ovariectomies. Around this opening on the cutaneous aspect of the cloth is spread some adhesive material, such as emplastrum adhesivum; this, heated before operation, serves to glue the mackintosh to the parietes, and so prevent soiling of clothes, and secures isolation of the part to be operated upon. The mackintosh also prevents loss of bodily heat by radiation, and keeps away from the wound particles of wool, cotton, or other dust given off by the clothing.

*Preparation of Patient.*—The general preparation of the patient includes free opening of the bowels; it is better to do this by gentle purgation for two or three days before operation than by a single sharp purge the night before. During the twenty-four hours preceding operation all food should be either liquid, or of a nature to leave little residue in the intestines. The last meal will be regulated by the orders of the anaesthetist. Many surgeons give the patient morphia before operation; a few speak highly of the value of strychnia given hypodermically as a means of keeping the bowels contracted during and after operation. A thorough cleansing of the whole body in a bath with soap should precede operation.

Locally the seat of operation is purified in the manner described

under "Antiseptics" (p. 270). The pubic hair is shaved. The risk of infection, however, lies rather in the numerous and large hair-follicles in this region than in the hair; it is indeed doubtful if this region is ever rendered perfectly sterile. Therefore it is wise at and after the operation to use active antiseptics on the skin over the pubes. A good plan is to rub powdered boric acid dissolved in carbolic lotion into the skin in this region. This plan will certainly keep the skin sweet for a week; thereafter the risk is over.

*Arrangements for Operation.* — The placing of the table, surgeon, and assistants is shown in the accompanying diagram. The patient's feet are towards the window or chief light. The surgeon stands on the patient's right; his assistant—only one operating assistant is necessary—opposite

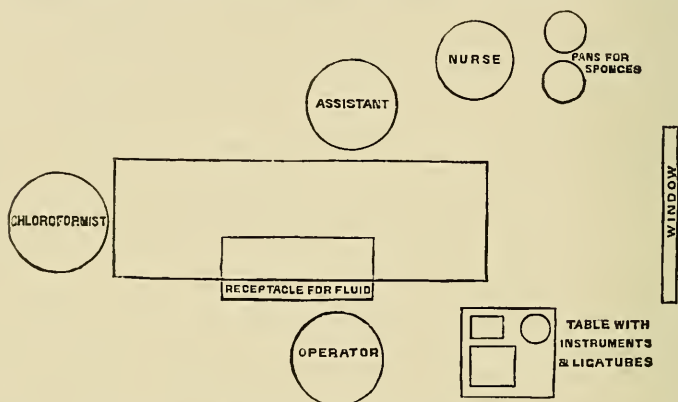

FIG. 212. — Diagram to show placing of table, surgeon, assistants, nurse, and instruments in ovariectomy. (After Doran.)

to him on the patient's left. The nurse stands behind the assistant, takes sponges from his hand, cleanses them, and returns them dry as they are wanted. The instruments lie on trays covered with sterilised water, or in antiseptic solution, close to the surgeon's right hand. The surgeon should help himself to instruments — an assistant to hand them imports another risk and is quite superfluous. A swinging tray, attached to the table on which the instruments are placed, which can be brought close to the seat of operation, is a convenience for holding the instruments which are in constant use.

*Sponges and Sponge-cloths.* — A dozen sponges of undoubted purity should be in readiness. These should be assorted as follows: two large flat sponges, two medium flat, and eight round of various sizes. The sponges should be of the finest Turkey growth.

Two dozen sponge-cloths kept in warm sterilised or antiseptic solution are also at hand. For absorbing fluids and blood, for covering extruded bowels, and in numerous other ways, sponge-cloths are invaluable. They are laid on the mackintosh all round and close up to the



parietal wound, keeping the operating field aseptic and absorbing any fluids that escape. As soon as a sponge-cloth is soiled the assistant quietly replaces it by a fresh one. As a rule, sponge-cloths only are used during the making of the parietal wound, and many operations are finished without the use of a single sponge.

Artificial sponges, made of pads of absorbent material in gauze bags, are used by some surgeons. They do not absorb so well as natural sponges; and they are no more safe, if due care be observed in preparing the natural ones. If gelatinous fluid has to be removed from the cavity of the abdomen natural sponges are almost essential.

*Instruments.* — The surgical armamentarium may conveniently be as follows: —

One scalpel; one scissors, dissecting, elbowed; one scissors for sutures and pedicle, flat; twelve hæmostatic pressure-forceps, small; six hæmostatic pressure-forceps, medium; two T-shaped forceps; four cyst-forceps — large — straight; four cyst-forceps — large — bent; one

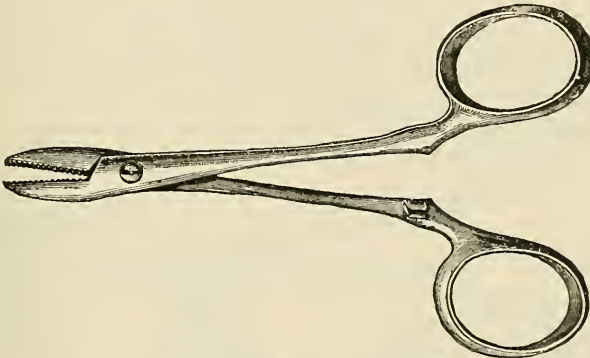

FIG. 213. — Tait's modification of Wells' catch-forceps.

forceps for placing pedicle ligature; one cyst-trocar — Tait's large; one cyst-trocar — Wells' — Fitch's dome; one suture-needle (several sizes of needle); one reel-stand with silk ligatures; six glass drainage tubes — assorted.

With these instruments most ovariectomies may satisfactorily be performed. In reserve, however, and sterilised ready for use, should be the following: —

Aspiration apparatus; intestinal needles; Lane's intestinal clamps; cautery irons, or thermo-cautery; a second dozen of pressure-forceps; abdominal retractors; means of providing artificial light with mirror, electric apparatus, or otherwise.

The instruments are arranged in trays containing warm sterilised water or carbolic lotion. They should be arranged in groups, and so placed that the surgeon can put his hand in a moment on the instrument he wants. An instrument after use is replaced in its tray. The tro-

cars, with tubing attached, are placed in a special large basin. The reel-holder, containing at least four sizes of Chinese silk, stands by itself; the ligatures are pulled out and cut off by the surgeon himself as they are wanted.

Some of the most important instruments may be briefly described.

Of forceps, the best and most generally used is that known by Spencer Wells' name (Fig. 213). Tait has, I think, improved the model by making the blades shorter and more pointed, thus giving more power in grasp, and permitting the ligature to slip more easily over the point. In these instruments the blades are serrated transversely to their length, and the tissues caught in them are thus flattened out and wrinkled, while lateral traction is liable to cause them to slip.

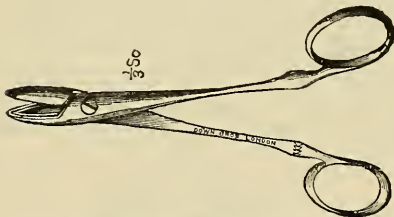

FIG. 214. — Catch-forceps. (Author's model.)

For some years past I have been using forceps of the same size and shape, in which the serrations are carried round the blades parallel to their margins instead of across them. The

tissues are thus sharply compressed along two lines, and an uncompressed bulb of tissue lies in the centre of the blades which effectually prevents slipping, and serves to hold the ligature.

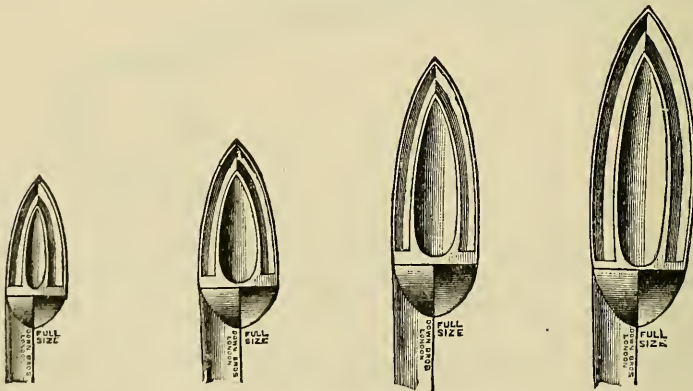

FIG. 215. — Blades of author's forceps.

As hæmostatic agents these forceps are, in my opinion, superior to those with serrated flat blades; they sharply compress, almost divide, any vessel included: rarely has any ligature to be applied to a bleeding point on which they have been placed. They are made in all sizes and shapes. The smallest size (Fig. 216), with one biting edge and a sharp point, is used for picking up the

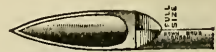

FIG. 216. — Author's peritoneal catch-forceps.

peritoneum; of larger size they are useful in seizing the slippery cyst-wall, and in holding omentum that has been stripped. The largest

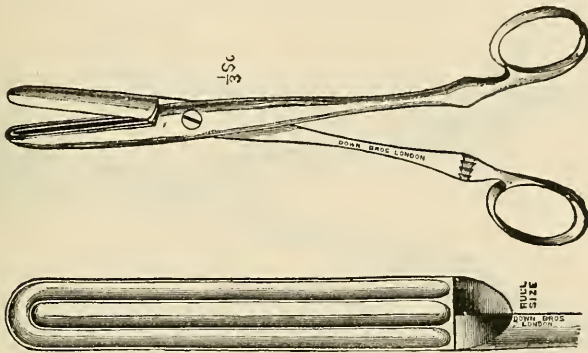

FIG. 217 — Large pressure-forceps; straight. (Author's model.)

size is convenient for grasping broad masses of tissue, and is made straight, T-shaped, and bent at various angles. These instruments are

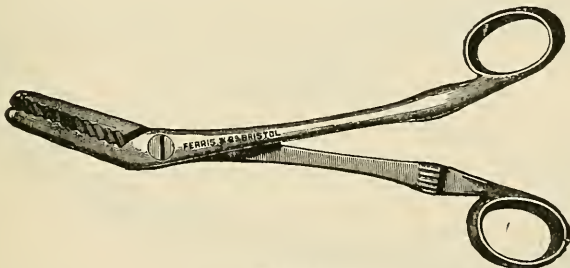

FIG. 218.

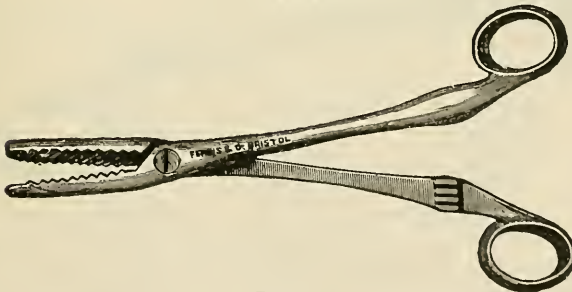

FIG. 219.

Wells' large forceps, bent (Fig. 218); and straight (Fig. 219).

all made on the Wells' pattern as regards handles and blades; the only variation is in the form of the biting surfaces of the blades.

The large forceps of Wells, straight and bent (Figs. 219 and 218); the

same instruments with the blades at right angles (Fig. 220) and T-shaped (Thornton) (Fig. 221) are in universal use and are highly appreciated;

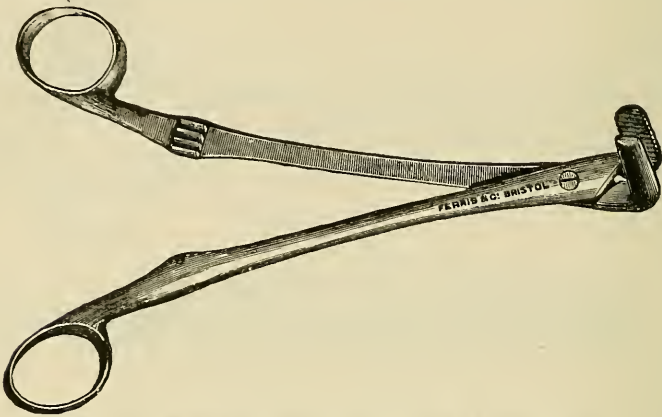

FIG. 220.—Wells' large pressure-forceps, rectangular blades;  $\frac{1}{2}$  size.

their handles are similarly shaped; they all have the rack catch, which is quickly applied and released, and they are very powerful. A clamp

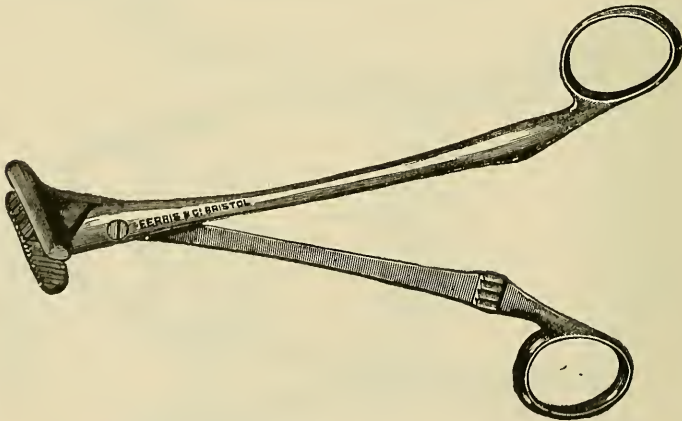

FIG. 221.—Thornton's T-shaped pressure-forceps;  $\frac{1}{2}$  size.

forceps with screw compression used by Wells (Fig. 222) may occasionally be found useful.

For grasping and dragging out the cyst, Nélaton's special forceps (Fig. 223) have been much employed and found very valuable. The spikes in the blades are supposed to add to their holding power; I think they tend to lacerate the parts.

Excellent cyst-forceps are those of Sydney Jones (Fig. 224), but as



cyst-forceps I consider those already described with double parallel serration to be the best.

On cutting instruments little need be said. I have used the same

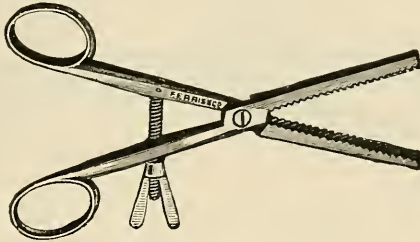

FIG. 222. — Wells' clamp-forceps;  $\frac{1}{2}$  size.

scalpel in several hundreds of operations; it has never been to the instrument maker, but is sharpened by a few strokes on steel or hone

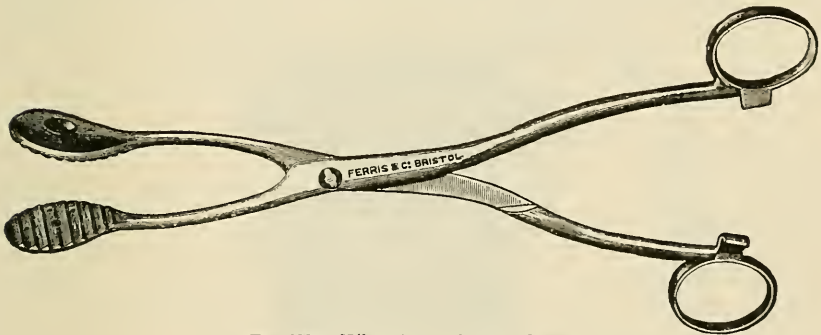

FIG. 223. — Nélaton's cyst-forceps;  $\frac{1}{2}$  size.

before every operation. The scissors which I use have the same handles as catch-forceps; their blades are bent a little, rounded, and rather sharp



FIG. 224. — Sydney Jones' cyst-forceps.

pointed. They are useful in delicate as well as in coarse work. Separate scissors, curved on the flat, should be used in the division of ligatures and sutures.

The ligatures used in ovariectomy are most conveniently made of silk; Chinese twist in four assorted sizes, from the smallest to the largest, will

suffice. These ligatures must be absolutely aseptic. For keeping the ligatures I can confidently recommend my own holder (Fig. 226). It is

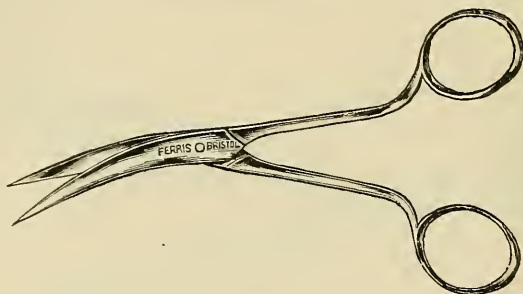

FIG. 225. — Author's scissors.

composed of a stand with weighted base made of metal which will not rust, and which can be removed and placed in boiling soda solution; and of a vulcanite case with screw cap, which is air-tight. If the stand with

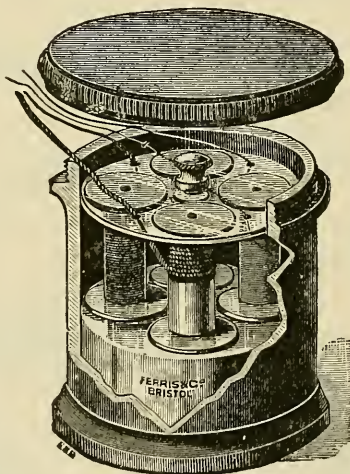

FIG. 226. — Author's reel holder;  $\frac{1}{2}$  size.

the reels is boiled now and again, and 1–20 carbolic lotion poured into it for every operation and decanted afterwards, the silk, thus kept in carbolic vapour and away from the possibility of contamination by air, may always be trusted.

These instruments are in constant use throughout the operation. Special instruments required in special parts of the operation are tapping trocars, pedicle needles or forceps, drainage tubes, and needles for placing the sutures in the parietal wound.

Of tapping trocars the best known is Spencer Wells' (Fig. 227), which contains an inner blunt tube in an outer cutting tube, and two spring clasps with sharp teeth to hold the cyst wall. A very useful tube in

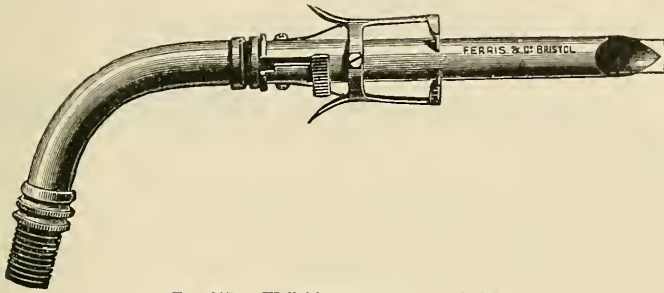

FIG. 227. — Wells' large cyst-trocar;  $\frac{1}{2}$  size.

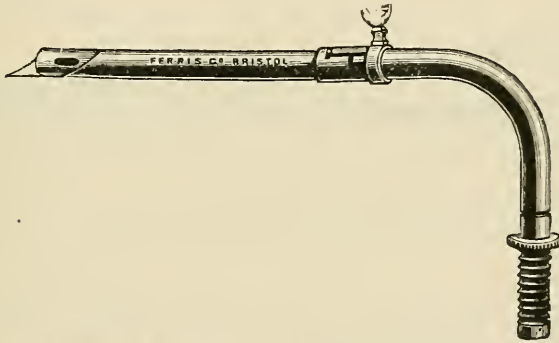

FIG. 228. — Wells' small cyst-trocar with Fitch's dome;  $\frac{1}{2}$  size.

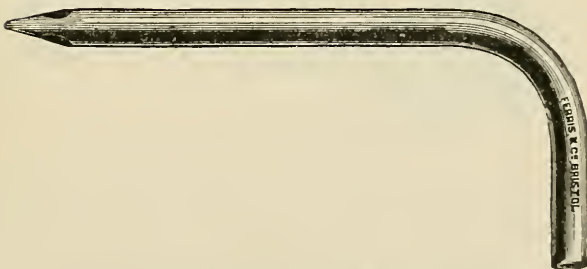

FIG. 229. — Tait's cyst-trocar;  $\frac{1}{2}$  size.

smaller size was also designed by Wells, with Fitch's safety dome which can be pushed beyond the cutting point (Fig. 228).

The trocar which I like best is that of Lawson Tait (Fig. 229). It does not cut at all; it pierces and dilates. It is a simple piece of metal

tubing, bluntly conical, and bent to a right angle in the shaft. It can be had of all sizes; the largest size is rarely too large.

To the trocar is attached a piece of thick rubber tubing of the same calibre as the trocar. The tubing must have thick walls to prevent the chance of its becoming blocked by kinking.

For carrying the ligature through the pedicle various needles are in



FIG. 230. — Sydney Jones' pedicle needle.

use (Figs. 230, 231). Any needle will do if it is curved, handled, and blunt. An aneurysm needle does very well. I employ a forceps with



FIG. 231. — Wells' pedicle needle.

blades and points like those of Lister's sinus forceps, but bent (Fig. 232). The closed instrument is pushed through the pedicle; the blades are

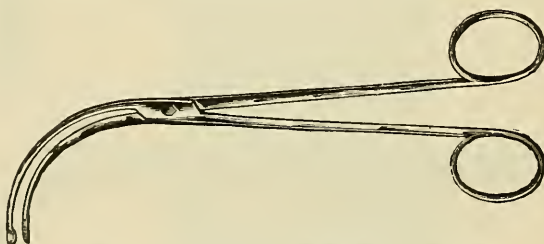

FIG. 232. — Author's forceps for placing ligature on pedicle.

then opened and made to grasp the ligature which is placed during withdrawal.

Of drainage tubes the original ones of Keith (Fig. 233), of the



FIG. 233. — Keith's glass drainage tube;  $\frac{1}{4}$  size.

same diameter throughout, with a collar and with a few perforations near the point, are still the best.



For the drainage of large opened up spaces a drainage tube, shaped like a test-tube, with perforations nearly all the way up, is sometimes of advantage (Fig. 234). The sharp rim of a Keith's tube must not be



FIG. 234. — Glass drainage tube ;  $\frac{1}{2}$  size.

pressed down on the rectum or other part of bowel for any long time, as it may cause perforation.

A sponge-holder, with blades long enough to reach to the loins, should be amongst the instruments in readiness (Fig. 235).

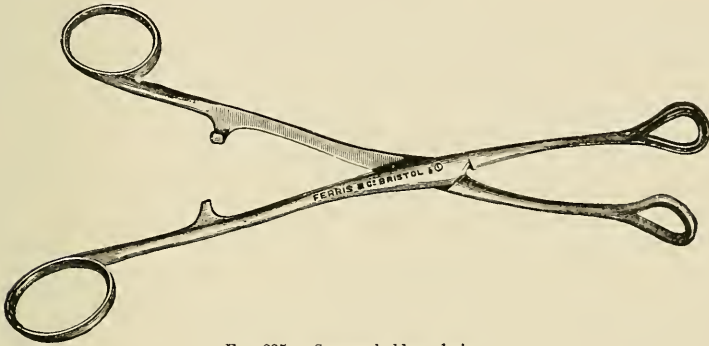

FIG. 235. — Sponge-holder ;  $\frac{1}{2}$  size.

In placing the sutures in the parietal wound most surgeons have special methods of their own. The instrument shown (Fig. 236) does

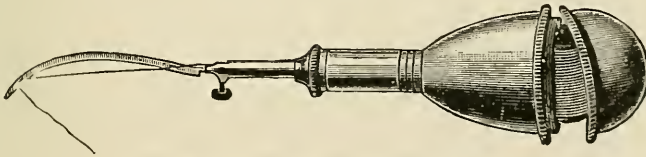

FIG. 236. — Author's suture instrument ;  $\frac{1}{2}$  size.

equally well for silk or for silk-worm gut. The silk, preferably plaited, is held on its reel in a cavity in the handle, which is filled with antiseptic solution. If silk-worm gut (in my opinion the best suture material) be used the reel is discarded, and each suture is passed into the eye of the needle after the needle has been carried through both sides of the incision: the suture is thus placed on its withdrawal. The needle is on Hagedorn's principle, except that the eye is at the point. Hagedorn's needles, used with his holder, serve the purpose admirably. Some surgeons use ordinary glover's or similar needles.

**The Operation.** — The patient being anaesthetised, and sponge-cloths wrung out of warm lotion having been laid around the field of operation on the mackintosh, the actual operation is begun by —

*The parietal incision*, which is made in the middle line, and lies, as a rule, midway between umbilicus and pubes. If the tumour be large the incision lies nearer to the pubes than to the umbilicus. It is not advisable to go closer to the pubes than two inches, on account of the proximity of the bladder; if it be necessary to enlarge the opening the wound is extended upwards. The first incision will vary from two to five inches in length, according to the thickness of the parietes and the amount of solid matter in the tumour. In a few cases it may have to be enlarged to six or eight inches.

The first cut usually divides the skin and fatty tissue down to the fibrous aponeurosis. In very stout persons the fatty layer may be several inches in thickness, and this may be increased in thickness by œdema. In very thin persons, with distended abdomen, the subcutaneous fat may be absent. Catch-forceps are placed on bleeding points: these may be removed as soon as the cavity is opened; in a few seconds hæmostasis will be complete and permanent, and ligatures will be unnecessary.

The fibrous aponeurosis is next divided as nearly as possible in the linea alba. A glance at the arrangement of the fibres will often, by their symmetrical arrangement on the two sides, show the exact middle line; but frequently the linea alba is not hit off, or not divided at all, but one or other sheath of the rectus is entered. In persons with powerful recti, and not very distended parietes, the linea alba may be no more than a thin fibrous septum; in women with thin or distended parietes the linea alba may be broad, and there will then be no difficulty in avoiding the recti. But to expose either or both muscles does no harm; indeed, some surgeons say that to expose muscle and bring it into the line of union is a distinct advantage, as it helps to prevent ventral hernia. There is certainly no advantage in being far from the middle line; if the sheath be opened it should be close to the linea alba. A small cut is made with the scalpel through the thick aponeurosis; a glance will show whether it is far from the middle line, and on which side: it is then extended upwards and downwards towards the middle. Below the falciform edge, where most operations are done, there is no more aponeurosis to divide; above this level the wall of the sheath of the rectus remains to be divided.

The subperitoneal fatty and areolar tissue is now exposed. It is naturally very loose and elastic, and it can readily be teased apart so as to expose the underlying peritoneum. Occasionally it is very sparse in amount; sometimes it is thickened and hardened by inflammation, and firmly adherent both to peritoneum and to muscle. The fat is pushed to one side and the other, and a minute portion of peritoneum is caught up in the fine peritoneal catch-forceps and pulled to the surface. A second forceps is placed close to the first, by its side; the minutest grip suffices to give a holding. Between the two pairs of forceps the

raised fold is gently sawed through by a knife, air rushes in, the bowels fall back, and the opening is enlarged to a size sufficient to admit the forefinger. The left forefinger is introduced through the opening, and the peritoneum divided on it upwards and downwards to the full extent of the outer incision by scissors. Any small vessel which bleeds is at once seized in catch-forceps, which are left hanging for a few seconds, or till after the cyst is emptied.

In ovariectomy the incision has rarely to be increased beyond a length of four or five inches. This is best done by scissors dividing the whole thickness of the wall at each stroke. If the incision has to be carried above the umbilicus it should be carried to the left of it; this is done to avoid the round ligament of the liver and the thin tissues, not suitable for holding sutures, in the umbilicus itself.

When the peritoneum is adherent to the underlying tumour its separation requires some judgment and experience. It has frequently happened that peritoneum has been stripped from parietes in the belief that tumour was being stripped from peritoneum. An inflamed and thickened peritoneum is usually vascular and somewhat friable.

*Emptying and delivering the Cyst — Separation of Adhesions.* — The tumour being exposed and found suitable for removal, it is tapped at once. It is unnecessary to introduce fingers, still less the hand, unless the diagnosis be doubtful. Adhesions are best left till the cyst is emptied.

A point for inserting the trocar should be selected in a large and thick-walled cyst; small thin cysts and the sulci between them should specially be avoided. Tait's large trocar is, as a rule, the most convenient. If the cyst-wall be thick a slight cut with a scalpel through the outer layers facilitates the introduction of the blunt point of the trocar. The trocar is plunged in with the left hand, and fluid at once flows into the receiver through the rubber tubing. Almost simultaneously the cyst-wall below the trocar is grasped in cyst-forceps held in the right hand, and is pulled to the surface. Deft manipulation will always avoid the escape of fluid into the peritoneal cavity, and will bring the rapidly collapsing cyst-wall outside the parietal incision. The parietes are not pressed back on the cyst; rather is the cyst pulled outwards and on to the parietes. A second pair of forceps, placed on the cyst above the trocar, suffices to hold the opening in the cyst outside the wound during the emptying, and perhaps to deliver the whole tumour.

Delivery is prevented by the presence of semi-solid polycystic material in the growth, and by adhesions. Secondary cysts may be emptied one after the other by pushing the trocar into them. If they are very closely set and very numerous, the trocar is now removed, and two fingers of the right hand are carried through the opening to break the numerous small cysts into the large one; or the openings in parietes and cysts may be enlarged and the whole hand introduced to break up the cysts. Meanwhile the assistant, holding the large catch-forceps, keeps the cyst opening well outside the parietal opening, and turns it so that any fluid

escaping shall run over the mackintosh into the receptacle provided. If the fluid be very foul a sponge-cloth or two laid around the parietal opening will provide additional security against its entering the abdominal cavity. When the whole of the semi-solid matter has been broken up the hand is removed, and the contents are squeezed out by pressure on the parietes: these run over the mackintosh into the vessel under the table.

The cyst may now be delivered through the parietal opening. This is done by traction on the attached forceps, one pair after another being placed as the tumour comes out. If the walls are very friable the largest forceps, with slight compression, should be employed. The advantages of my instruments, which hold very firmly, and neither pierce nor cut, are most conspicuous in the handling of cysts with friable walls.

If delivery is prevented by adhesions these are now dealt with. If the cyst has not been completely emptied, and if there is any risk of the fluid escaping into the cavity, the opening in the cyst is closed by pressure-forceps suitably placed around the opening. Adhesions, wherever possible, are separated within sight; but many adhesions, such as those to the liver, must be separated far from vision by fingers. In the separation of fine, soft, or recently formed adhesions, the hand or fingers working their way over the cyst-wall easily succeed. Such adhesions bleed very little, and the bleeding soon ceases. The use of a sponge is often advisable. The adherent organ is sponged away from the cyst-wall; if there is any bleeding the sponge is left on the detached organ, and removed later with the blood which it will have absorbed. Firm adhesions must be dealt with more deliberately. Sometimes they may be peeled off by the fingers, or fingers aided by sponging; each strip of adhesion is examined for bleeding after detachment, and a forceps placed on it. Old, firm, and fibrous adhesions are divided and tied on the distal side; a catch-forceps is left on the tumour side, and removed with the tumour. Omental adhesions are perhaps the most common; they can usually be peeled off, but nearly always demand forcipressure. Coils of intestine adherent in the sulci between cysts require very careful handling. It is better always to detach a piece of cyst-wall with the gut than to injure the latter by tearing, or by denuding it of its outer coats.

Forceps holding bleeding points in adhesions are, wherever possible, brought outside the parietal opening, and laid on and covered up by sponge-cloths.

Where the adhesions lie deeply large forceps are attached the handles of which remain outside; and sponges in such cases are packed inside the abdomen over the raw surfaces. When the tumour is delivered and cut away the forceps are removed one after another; and the tissues caught in their blades are closely examined. In most cases where forceps have been compressing bleeding vessels hæmostasis will be perfect, and the adhesion may be allowed to slip inside. Where there is any sign of bleeding or of oozing, a silk ligature is placed before the adhesion is returned. In bad cases from a dozen to two dozen forceps may be left on, each holding its own bleeding point; yet when they come to be



removed a few minutes later, not a single ligature may have to be applied.

*Treatment of the Pedicle.*—The pedicle is now almost universally secured by ligature, the stump being dropped into the abdominal cavity. The only method which for safety can compete with intraperitoneal ligature is that of Thomas Keith by clamp and cautery. As, however, this is more troublesome and no more safe than the method by ligature, the latter alone will be described.

The material which is most convenient for ligation is the silk thread known as "Chinese twist." Silk can be sterilised easily and satisfactorily by boiling. It does not swell, and it holds firmly the grip which we make it take. It becomes quietly encapsuled, remaining quiescent in its bed, and is slowly absorbed in the course of a few months.

Various thicknesses of silk are used according to the size and the vascularity of the pedicle. By compressing the pedicle along the line of ligature with strong forceps, the chief necessity for using very thick silk—to bear a strong strain in tightening—is done away with. Silk of medium thickness will easily check the bleeding if the fibrous tissues which surround the vessels and protect them from compression are first squeezed by pressure-forceps. The silk should always be strong enough to bear the strain of hands of moderate strength, but need not be so strong that it cannot be broken. It is better to tie the pedicle in several sections with silk of moderate thickness than to tie in one or even two masses with very thick silk. In every case, if only to prevent slipping, it is wise to use a transfixing ligature.

To carry the ligature through the pedicle a blunt instrument should be used, so as to prevent the possibility of wounding any of the thin-walled vessels. The blunt needles of Sydney Jones (Fig. 230), or of Spencer Wells (Fig. 231), serve the purpose admirably. An aneurysm needle, if it has a long curve, does very well. I use a curved forceps with blades like a sinus forceps (Fig. 232); this is pushed through the pedicle at the points selected: its blades are opened after being passed through, and the ligature is caught in them and placed during withdrawal. All trouble of threading and unthreading is thus done away with, and a series of ligatures can be placed with great rapidity and ease.

If a simple transfixing ligature, securing the pedicle in two sections, be used, no method is superior to that of Lawson Tait by the Staffordshire knot (Fig. 237). If the forceps be used the ligature is placed with great ease. Firstly, the forceps is passed through the pedicle; then the silk is placed below it around the whole pedicle; then the two free ends are caught between the opened blades and withdrawn. One end of the ligature is placed above the encircling loop, and another below. The two ends are pulled tightly by the right hand, while the finger and thumb of the left hand

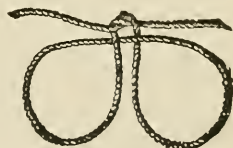

FIG. 237.—Tait's Staffordshire knot.

compress the line of ligature; the knot is cast and tied in the ordinary way. If a needle be used to carry the ligature through, the loop is raised over the tumour to the side of entrance, and the two free ends, one above and one below the loop, are tied as described.

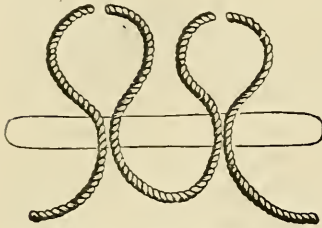

FIG. 238. — Triple interlocking ligature; threads inserted, loops divided.

If the pedicle be a large one it may conveniently be tied in three or more sections. The ligatures should always be made to interlock, so that the whole mass is kept together, and there is no downward splitting with possible injury to delicate vessels. With the pedicle-forceps a series of ligatures may be very rapidly and easily placed in one long thread (Figs. 238, 239, 240). Two, three, or four loops are pulled through as we desire to place three, four, or five ligatures; the loops are divided, and the ligatures then lie ready for tying. The middle ligature is tied first; and before a ligature is tied the ligature on each side should be looped in it. With a properly placed interlocking or chain ligature, the largest pedicle may be compressed into wonderfully small bulk. Compression by large forceps along the line of ligature will materially facilitate the tightening.

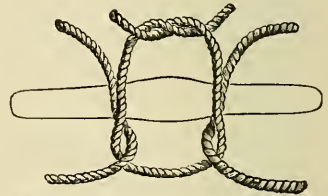

FIG. 239. — Triple interlocking ligature; threads interlocked ready for tying.

While the ligatures are being tied there should be no traction on the pedicle by the weight of the tumour, or otherwise. In vascular or fleshy pedicles it is often good practice to hold the ends of the ligature, and to keep tightening it while the assistant cuts the tumour away; the same purpose is served by forceipressure. When the ligatures are tied, and the tumour is cut away, a final examination of the stump and ligatures is made, and if all be secure the pedicle may be let slip into the cavity. If there is sponging or further manipulation to be carried out, I usually place a medium-sized forceps on the tissues in the middle of the stump, and leave it there till the end of the operation, when a final glimpse is given to it to make certain that all is secure.



FIG. 240. — Triple interlocking ligature; threads tied.

the pedicle may be let slip into the cavity. If there is sponging or further manipulation to be carried out, I usually place a medium-sized forceps on the tissues in the middle of the stump, and leave it there till the end of the operation, when a final glimpse is given to it to make certain that all is secure.

In placing the ligature there is no advantage in getting deeply inside the abdomen or close to the uterus. The ligature should be about half an inch away from the tumour, and division is made by knife or scissors just free of tumour tissue. No doubt tumour tissue has often been left behind in the stump, yet it is a significant fact that no case of recurrence of ovarian tumour on the side of removal has yet been recorded.

In cases of torsion of the pedicle I place the ligature at the site of

greatest twisting, and do not undo the twist. The ligature is thus made to complete what nature has begun. In cases of large fleshy pedicles a flap of peritoneum may be left to cover the raw surface, and so serve to minimise the risk of obstruction from intestine getting adherent to it. It can easily be fixed over the stump by a continuous suture of fine silk.

When the pedicle is secured the alternate ovary should be examined. If there be any sign of disease it also should be removed.

*The "Toilet of the Peritoneum."*—The wound should not be closed until all foreign matter—such as blood, ovarian or ascitic fluid, or pus—has been removed from the abdominal cavity. In most cases, after delivery of the tumour and before division of the pedicle, a sponge will have been placed inside the abdomen under the parietal wound. This sponge will have gathered to itself any free fluid that may lie in the lower pelvis, and its contents on removal after ligature of the pedicle will be some guide to the amount of fluid present. A sponge in a long sponge-holder (Fig. 235) is dipped into the pelvis behind the uterus. If it return dry, or nearly so, no further sponging is necessary. Then the sponge is carried successively into each lumbar hollow over the kidney to make certain that no fluids have gravitated thither.

If the fluid be present in moderate amount it is removed by successive introductions of sponges. Each saturated sponge is squeezed dry, cleansed in sterilised soda solution, placed in hot carbolic lotion, again squeezed dry, and returned to the surgeon, who picks it up in the sponge-holder and reintroduces it. Blood in the presence of ascitic fluid clots at once; and wiping of surfaces, or even a little friction may be necessary to remove it. Glairy, thick ovarian fluid is not readily mopped up; rotation of the sponge helps in its removal. If, by mischance, pus have escaped into the cavity, irrigation is, I think, always advisable.

Irrigation is to be used when there has been much wounding of peritoneal surfaces with escape of blood; or where pus or thick ovarian fluid has escaped into the peritoneal cavity. This is done by pouring into the cavity some unirritating sterile fluid, and literally washing the bowels and peritoneum in it. Of all fluids, for this purpose the least irritating is, in my experience, a solution of Barff's boroglyceride of the strength of half an ounce to the pint of water. Saline solution and simply sterilised water may safely be used, but these cause more injury to the delicate endothelium than boroglyceride. The fluid should be at a temperature of 100° F., or even a few degrees warmer. The solution may be poured in out of a jug while the edges of the parietal wound are dragged forwards. The fingers then freely move the intestines about in the fluid, washing them, disturbing clot and breaking it up. By depressing the parietes the fluid is permitted to flow out, and is guided over the mackintosh into the vessel provided for its reception. I prefer always to use irrigation, the reservoir being raised from three to six feet above the patient, according to the cohesiveness of the materials to be removed. A specially devised glass tube with perforated bulbous ends is attached to the rubber coming from the irrigator; and this,



throwing out numerous jets of fluid, is carried over all the districts which it is desired to cleanse. The wound is pinched round the tube until some pints have flowed into the abdomen, and it has begun to be distended; the wound is then made to gape, and the fluid comes out with a gush carrying débris with it. This may be done repeatedly till the fluid returns quite clear. A little judicious manipulation, accompanied with kneading of the parietes, and perhaps turning of the patient on one side, will cause most of the fluid to escape. If drainage is to be carried out it is not necessary to remove the fluid, in fact it is, I think, better to leave it behind, for clotting of blood does not then take place; if there is to be no drainage the fluid must be removed by sponging in the manner directed.

If irrigation is employed there should be no stinting of fluid—gallons rather than pints should be the measure. The bowels should be freely moved about with the fingers in the cavity during the irrigation, so as to ensure disturbance of every lurking particle of foreign matter.

It is possible to overdo the peritoneal cleansing. Too much sponging irritates the peritoneum and causes it to secrete fluid, and removal of every particle of clot encourages vessels to go on bleeding. Sponging may cease when no more than a drachm of fluid can be squeezed from the sponge. If the drainage tube is to be employed, as will usually be the case after irrigation, sponging is not called for at all.

*Drainage.*—It is quite impossible to lay down accurate rules as to the employment of the drainage tube in ovariectomy. It is certainly true that drainage has done more good than harm; with moderate care it can scarcely do harm: therefore it is a good rule to drain when in doubt. If fluids do not come away the tube may be removed in twenty-four hours, and no harm is done. If fluids do come away we have the satisfaction of seeing the good done.

If we expect a pouring out of fluid, serous or sanguinolent, more rapid than the peritoneum can dispose of we should drain. This would occur after extensive traumatism in the separation of adhesions. If we expect bleeding from vessels which cannot be secured we should drain, and in any case where hæmorrhage is feared we should drain. In all cases where purulent or septic fluid has escaped into the cavity we should drain. Where intestine or bladder or other viscus has been wounded, with escape of their contents, we should drain. And in most cases where irrigation has been employed it is wise to drain.

Keith's drainage tubes (Fig. 233) are for most cases the best. The tube selected should be long enough to reach the bottom of the pouch of Douglas without pressing on the rectum, while the collar rests on the skin at the lower end of the wound. Inside the tube should be placed a few strands of gauze or thread to act as capillary drains. A circular sheet of rubber, in the centre of which a hole has been cut to admit the end of the tube, is folded over an absorbent dressing (nothing is better for this purpose than a sponge-cloth wrung out of warm carbolic lotion) which is removed as often as it is saturated. If there be bleeding,



frequent use of a suction apparatus to keep the abdomen perfectly dry is advisable. Tait's suction apparatus, or an ordinary glass syringe with a piece of rubber tubing long enough to reach to the bottom of the glass tube, should be employed for this purpose. If there is no clotting the capillary drain will serve to keep the abdomen dry without the use of the suction apparatus.

The gauze drain is very rarely employed after ovariectomy.

In most cases drainage need not be continued longer than two or three days; a few cases require drainage for a week or even longer. If the wound is thoroughly aseptic the opening made by the tube closes at once without suppuration.

Before placing the drainage tube it is a good plan to insert a silk-worm gut suture through the parietes at the point where the tube passes, and leave this to be tied after the tube is removed.

*Suturing the Parietal Wound.* — Some surgeons suture the wound in layers, each tissue having its row of buried sutures, interrupted or continuous. Most are contented with interrupted sutures, of which each includes all the layers in the parietes. Each suture should include skin and subcutaneous tissue, take a good hold of the fibrous aponeurosis, dip deeply into muscle, and pick up subperitoneal areolar tissue sufficient to give close peritoneal apposition on the raw surface. It should not pierce peritoneum. The sutures should be placed from two to four to the inch; thin and lean parietes require more sutures than thick and firm parietes.

As suture material silk-worm gut is unrivalled. For insertion of the sutures a curved needle on the Hagedorn plan is recommended. An ordinary Hagedorn needle does very well. With the needle which I employ (Fig. 236) the sutures can be placed with accuracy and rapidity.

Before suturing is begun, a sponge of suitable size is placed in the cavity under the parietes to keep bowels out of the way, and to collect any blood that may escape from the needle punctures. When all the sutures are placed the assistant grasps their ends in his two hands; the sponge is then removed and, from above downwards, the sutures are tied. If drainage is used, an extra suture may be placed where the tube passes, but is not tied; it is tied when the tube is removed.

A wound which is properly sutured should not be depressed, but should rather pout or bulge outwards. By burying the sutures deeply in the parietal muscle and fibrous tissues the uniting surfaces are broadened, and the adhesions are thereby increased in resisting power; superficial insertion of sutures contracts the uniting surfaces, and diminishes the bulk and strength of the adhesions. The aim should be to get union by a sort of flange-stitch which opens up and broadens the surfaces to be united.

*Dressings.* — Any dressing that is aseptic and absorbent will do. As a routine dressing I sprinkle a little boric powder around the wound, and then rub it into the skin with the fingers holding a few drops of carbolic lotion. Thus any germs that may be lurking in the hair-follicles, or amongst the epidermic scales, are rendered inert if not destroyed. Then a strip

of boric lint of four thicknesses is laid over the wound, and the whole is covered with long strips of strapping. Primary healing is practically universal; "stitch abscesses" are almost unknown. At the end of a week the wound is healed; but the stitches, if of silk-worm gut, may with propriety be left in for three weeks until the young cicatricial tissue has gained density and strength. I believe that buried sutures are of value chiefly because we cannot remove them; they keep up perfect apposition for about three weeks till they are absorbed. By leaving in ordinary sutures for three weeks we get this advantage.

Many varieties of dressing have been described. One of the best is that of Howard Kelly, which hermetically seals the wound and prevents the invasion of micro-organisms from without. He thus describes it (1):—

"After closure of the incision, the skin, the line of the wound, and the sutures are dried, and two layers of sterilised gauze or cheese-cloth, large enough to project from two to four inches beyond the incision on all sides, laid on the skin. This is saturated with the following adhesive mixture, which is evenly distributed over the whole surface: Squibb's ether or washed ether and absolute alcohol, equal parts; bichloride of mercury, enough to make the solution  $\frac{1}{10000}$ ; snowy cotton (Anthony's), enough to make a syrupy consistence, added in small pieces, stirring. As soon as this is poured over the wound evaporation takes place, and the celluloidin hardens, gumming the gauze fast to the skin. To avoid delay in waiting for this to grow quite hard, and to prevent adhesion to the cotton applied above it, the whole surface is freely dusted over with a finely powdered mixture of iodoform (one part) and boric acid (seven parts). The wound thus sealed with celluloidin may be left untouched for a week or more, when the dressing should be softened with water (or more rapidly with ether), the gauze lifted off, and the stitches taken out."

#### Variations in Method of Operating according to the Nature and Position of the Tumour

*In Dermoid Growths.*—The contents of dermoid tumours may be cheesy and thick, and refuse to run through the trocar. In such cases the best practice, if the growth be not very large, is to prolong the incision and deliver the tumour bodily. If the tumour is large, the whole space surrounding the tumour is packed with flat sponges; the two sides of the puncture in the cyst are caught by large catch-forceps and pulled forwards on the sponges, and the contents are then squeezed out by pressure on the parietes, assisted possibly by the fingers or hand inserted into the tumour cavity. The most scrupulous care should be taken to prevent escape of any of the sebaceous contents into the abdominal cavity. The greasy material once in the cavity is difficult to remove, and a small quantity left inside may be the source of peritonitis. Pure dermoid cysts are not often of large size; these cysts are, however, often of a mixed kind, and then may reach large dimensions. Dermoids would seem to be

more liable to rotation of the pedicle, even to the extent of complete separation, than other varieties of ovarian growth.

*In Solid Tumours.*—In the removal of solid tumours of whatever nature a long incision is necessary. For help in delivery, the insertion of a myoma-screw (Fig. 241) into the substance of the tumour may be of assistance. The force of suction is overcome by inserting the fingers between the tumour and the deep parts so as to admit air. When the tumour is delivered a large sponge or diaphragm is placed in the cavity over the bowels to prevent their extrusion. The pedicle in these cases is often very vascular and fleshy; it does not often include the Fallopian tube. The vessels being very thin walled are liable to be torn by transfixion, even with a blunt instrument; therefore unless the pedicle be thick and fleshy, a single encircling ligature is admissible. The pedicle is

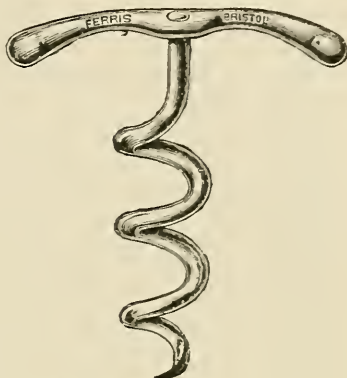

FIG. 241.—Screw for aiding in the delivery of solid tumours.  $\frac{1}{2}$  size.

first compressed by powerful forceps at the site of ligation. While the ligature is being tightened the tumour is cut off by scissors, every cut by the scissors permitting the ligature to be drawn more tightly; when division is complete the absence of bleeding from the divided surface shows that sufficient constriction has been exerted, and the knot is tied. If the pedicle be thick, a chain interlocking ligature, placed as already described, must be employed.

The rare *papillomatous tumours* of the ovary are removed in the same way as solid tumours. As they bleed freely on being handled, and as fragments of the papillary tufts are liable to be broken off and may infect the peritoneum, it is well to surround the tumour by a sponge-cloth before it is handled; and to carry out all manipulations while the tumour is wrapped up in the cloth.

*In Tumours growing between the Layers of the Broad Ligament.*—Certain tumours having origin in the ovary, the paroophoron and the parovarium, are liable to develop between the layers of the broad ligament. An ordinary cystoma may do this; it is then known as “encapsuled.” Tumours originating in the parovarium—simple parovarian cysts—may be encapsuled. Papillomatous cysts, which undoubtedly frequently originate in the paroophoron or hilum of the ovary, are very frequently encapsuled; that is, they grow between the layers of the broad ligament, and open them up. Some cases have half the cyst outside and half inside the peritoneal covering; some are completely enveloped. Papilloma-bearing cysts may present many difficulties in removal.

A tumour, opening up the broad ligaments and covered by peritoneum and its underlying areolar tissue, has a pink opaque surface, very different

from the white or gray glistening surface of the wall of a cystoma. It is tugged as usual, and, as far as possible, delivered. There will be no proper pedicle; the whole length of the broad ligament may be involved, and the growth may dip deeply into its substance.

In the enucleation of all these tumours two practices may wisely be followed: firstly, to begin by tying off as much tissue as possible at the uterine cornu, this will check all bleeding coming from the anastomosis between the uterine and ovarian arteries, which is the chief blood-supply; and, secondly, to do as little enucleation as possible, but instead to carry division of the broad ligaments well down into the pelvis. It saves bleeding to cut off the utero-ovarian blood-supply from the beginning. It saves time, and removes superfluous and perhaps dangerous tissue, to cut away with the tumour large flaps of the spread-out broad ligaments. It is waste of time to separate flaps of peritoneal tissue from the tumour-wall when both are to be removed.

In such cases a ligature is placed, by transfixion with the bent pedicle forceps, between the uterine cornu and the tumour; then the areolar tissue beyond the ligature is opened up. Guided by the forefinger, the peritoneum is divided in a line leading as nearly as possible straight between the cornu and the pelvic attachment of the broad ligament. Catch-forceps are placed on the bleeding points as they appear, and are left attached till enucleation is complete, when they may be replaced by ligatures if necessary. Usually, however, forcipressure for a few moments will be found sufficient to check all the bleeding. When a beginning is made, enucleation may usually be carried out very rapidly by the fingers, an adhesion here and there being caught in forceps and divided.

The raw surfaces left after enucleation should be covered in by suturing together the peritoneal free margins, otherwise bowels will become adherent to them, and obstruction may ensue. The danger of the formation of a hæmatoma between the layers of the ligaments is avoided by securing perfect hæmostasis, and perhaps by placing a small rubber tube in the cavity, and taking it out at the bottom of the parietal incision. It may be removed in twenty-four hours.

In some of these cases, more especially of the papillomatous variety, the whole of one side of the uterus, or even of both sides, may be entirely denuded of ligaments. In such a condition the checking of bleeding from the uterine vessels may require many ligatures, or even, as I have found, the application of the actual cautery.

**Ovariotomy during pregnancy** requires no special description for the early stages. In the later stages of pregnancy, if the tumour be well to one side and the uterus to the other, a lateral incision over the probable position of the pedicle will cause less disturbance of parts and give easier access than a median incision which necessitates some lateral displacement or even rotation of the uterus. Special care is given to the ligation of the pedicle which may contain large vessels. The operation in every case



should be performed with as little disturbance of parts as possible, so as to lessen the tendency to abortion.

**Incomplete Operations.**—The number of incomplete operations, instead of diminishing as we might expect, seems to be on the increase. We should expect their number to diminish because early diagnosis and early operation have made ovariectomy an easier operation than it was thirty years ago, when late diagnosis was more common, and delay until the patient could not walk was the rule. One experienced surgeon records no less than twenty per cent of unfinished operations, another three per cent. These cases are sometimes complacently put down as “recovered,”—more truly it might be said of them, “abandoned to death.” In England, amongst experienced operators, it is the rarest possible event to have an incomplete ovariectomy. In a personal experience of over two hundred operations, with no case refused, I have never left an operation incompleated. If, as most experienced surgeons insist, there is no cystic growth of the ovary which cannot be removed, a heavy responsibility rests on the surgeon who fails to complete the work he has begun. Deaths are certainly most numerous after the most desperate operations; these operations ruin statistics, but they save lives. In the belief that the interests of our patients and of surgery are best served by the completion of an ovariectomy once begun, I make no attempt to formulate rules for guidance in the case of operations left unfinished; nor any attempt to classify unremovable tumours, because, in the opinion of those most competent to judge, there are no such tumours.

**Accidents — Complications.**—An ordinary ovariectomy is one of the most straightforward and precise of operations, in which nothing but ignorance or want of experience can lead to error. But extraordinary cases are constantly met with in which unusual conditions lead to pardonable accidents. The most common of these may be described.

*Extrusion of Bowels.*—Through straining of the patient or sudden delivery of a tumour, intestinal coils may escape from the cavity and roll out over the abdomen. If the surgeon is engaged in other important work, it is the assistant's duty to prevent this by timely placing of sponges, or by the insertion of Maunsell's diaphragm. During delivery of a tumour the surgeon's left hand will instinctively seek to prevent extrusion of bowels. When many coils have escaped they are at once covered by a sponge-cloth; the forefinger of the assistant is hooked in under the top of the incision to pull the parietes well forward, while the surgeon, with both hands spread over the sponge-cloth, compresses and empties the intestines, and then slips them inside. A recurrence of the accident is prevented by the insertion of a suture in the wound, or by placing sponges or the artificial diaphragm.

*Stripping the parietal peritoneum* from the parietes in the belief that an adherent cyst-wall is being separated, is an accident that may happen to inexperienced operators. If the patient is thin there may

be but little subperitoneal fat, and the peritoneum may be so loosely attached that it readily peels off. The whole anterior parietes may thus be denuded by reckless manipulation. If the peritoneum be very thin and has been roughly handled, it had better be removed than left to the risk of gangrene. Occasionally separation of a very thick peritoneum adherent to a suppurating or gangrenous cyst is accidentally made. It is better to do this than to tear the cyst-wall, which may be on the point of rupturing at the seat of adhesion. Such pieces of separated peritoneum should be removed with the tumour.

*Rupture of the cyst-wall* in any way, but especially by pushing a trocar right through both sides of it, need not do much harm unless the contents of the cyst be putrid. Frequently the walls of the cyst are so friable that they will not hold together under the forceps, and tear even under gentle handling by fingers. In such cases it is impossible to prevent the escape of some of the cyst-contents, and this should be provided for by packing in large sponges under the tumour. We may have to operate for rupture of a cyst. In one such case I discovered almost accidentally, high up in the abdomen, a mass of gangrenous glandular tissue as large as the fist, which had escaped at the time of rupture and was embedded in adhesions. It was removed in the belief that it was an unreckoned sponge. Solid glandular masses may similarly escape during operation in cases of rotten cysts. Such rents may sometimes be closed by forceps. Complete delivery of the tumour is, however, the end to be aimed at; while during the manipulation it must be as completely isolated by sponge-packing as adhesions will permit. Irrigation will be called for in these cases.

*Hæmorrhage* to an alarming extent may be caused by injury to the walls of a very vascular tumour, or of one of the large pelvic or mesenteric vessels, or by division of vessels in adhesions. If bleeding from the cyst-wall is very free, and the tumour, on account of adhesions, cannot at once be delivered, a large pressure-forceps, placed temporarily on the pedicle, will check the bleeding for the time. I have met with a general varicose condition of the omentum and anterior parietes in a case of solid ovarian tumour, in which very free bleeding took place on handling. The occurrence of bleeding from injury to any of the iliac veins is a very serious accident, and difficult to deal with. A wound in a large vein may be sutured; a small vein should be tied on both sides of the wound or tear. General oozing from a large denuded surface may be controlled by firm pressure with sponges or gauze. Occasionally styptics, or the actual cautery, will be required. Hæmorrhage, after operation, is usually from an imperfectly secured pedicle: this, if in any quantity, requires reopening of the abdomen and satisfactory ligation. Effused clot will be removed and the cavity cleansed by sponging or irrigation. A drainage tube, inserted for a few hours, will add to the security.

*Injuries to the hollow viscera* may occur under the most skilful management, and are sometimes unavoidable. In every case they are

serious, and should be dealt with at the earliest possible moment. Intestine is usually lacerated during the separation of old dense adhesions, when the bowel is embedded in a deep sulcus between two cysts. It should be sutured at once by Lembert's or Dupuytren's method. The vermiform appendix is sometimes embedded in a sulcus, and firmly adherent; it is best to amputate it at once, and not to attempt to separate it from the tumour.

Injury to the walls of the bladder are more common than complete laceration. The latter condition, of course, demands accurate suturing. If the injury, while not penetrating the mucous membrane, involves the muscular coat to any extent, it is wise to place some puckering sutures for safety. Rupture of the gall-bladder is a rare injury during ovariectomy; the rent should be closed at once, and special gauze drainage provided through a separate opening.

The ureter is liable to accident, either by inclusion in the pedicle-ligature or by division. If the ureter be divided, and the accident discovered at the time, it is best to unite it at once by the operation known as uretero-ureterostomy. If the injury be discovered later in the progress of the case, either operation, or the implantation of the ureter into the bladder, may be carried out. The full management of the case in such a condition cannot here be detailed.

*Injuries to the solid viscera*—liver, kidney, or spleen—are not usually of serious moment. They are mainly of the nature of peritoneal denudations done during the separation of adhesions, and are dangerous only when there is excessive bleeding. The use of the actual cautery, or a solution of perchloride of iron, will usually be effectual in checking the bleeding; if these fail, gauze packing may be employed.

*Foreign bodies* left in the cavity—sponges, forceps, or other instruments—have caused a good many deaths after ovariectomy. Prevention is the best remedy here; instruments and sponges, before and after operation, should always be accurately counted. As soon as it is certain, or even probable, that a foreign body has been left inside, the abdomen should be reopened and the body sought for and removed.

*Intestinal obstruction*, following ovariectomy or oophorectomy, arises in most cases from adhesion of bowel to the stump of the divided pedicle. The false obstruction, arising from the intestinal paresis which accompanies peritonitis, is considered under treatment after operation, and need not here be dwelt upon.

About two per cent of all the deaths after ovariectomy are caused by obstruction, induced by kinking of a loop of bowel which has become adherent to the raw end of the divided pedicle. This accident is most liable to occur after removal of the appendages for myoma. Here the restricted space between tumour and parietes, in which bowel is caught and compressed, both disposes to the accident and aggravates the result of it. Traction of the adherent gut produces kinking, and this is, in most cases, the final cause of the obstruction.

Obstruction may be caused by the bowel getting caught in the

pedicle-ligature, or in a parietal suture. Holes left in omentum, mesentery, or broad ligament, may cause obstruction if the bowel slip through them and get entangled.

The symptoms of obstruction vary with the cause. In ordinary cases, caused by adhesion of bowel to pedicle, the symptoms come on at some period between the third and fifth day, and are of the ordinary character met with in non-operative cases. Vomiting, abdominal distension, insuperable constipation, and more or less collapse, may be expected. Where bowel is caught in a ligature the symptoms come on at once, and quickly become serious. It requires some experience and keenness of insight to diagnose intestinal obstruction with certainty after ovariectomy.

As soon as the condition is diagnosed the abdomen should be reopened and the gut liberated. Entrance may be made through the healing incision, by separating the adherent margins of the wound by finger or blunt dissector. If the cause is at the seat of the parietal incision it is removed almost on discovery. If at the pedicle, the bowel and pedicle are brought to the surface and separation is made under view. The adhesion in such cases may be very close and intimate; and, if intestinal wall is likely to suffer much injury in the separation, it is better to shave off a piece of the stump and leave it attached to the bowel, than to incur any risk of rupturing the intestine by separation. Any laceration of gut should be closed at once by a Lembert or Dupuytren suture.

**After Treatment.** — Nothing in the whole range of surgery is more remarkable than the ease and rapidity with which a patient recovers after an ordinary ovariectomy. If we let the patient alone, and do not worry her with fussy regulations and injudicious applications of tentative therapeutics, she will probably feel perfectly well on the third or fourth day. She may lie in any position she likes, on back or side; she may pass water when she desires, and need not do so before; and within wide limits she may drink what she likes, provided it is not cold and is absorbed by the stomach. To keep the patient in the supine posture, to draw the water at stated intervals, and to starve the patient of all liquids are quite unnecessary in the majority of cases, and cause suffering in not a few. Comfort is a therapeutic measure of real importance, and we should do everything possible to promote it. We should look with suspicion on any adjuvant to surgical healing which causes discomfort or suffering to the patient.

One of the most common complaints after ovariectomy is backache. The causes of it are various: the strain of keeping straight on a hard mattress a back which is naturally curved is probably one cause; it is certain that to turn the patient first on one side and then on the other affords most relief. A hot rubber-cushion or water-bottle under the sacrum often removes the aching. Changing the patient from one bed to another, with clean fresh linen and well-shaken mattress, is a luxury which is always highly appreciated.



Thirst in this, as in most other abdominal operations, is nearly always present. Some surgeons withhold all liquids by the mouth for the first twenty-four or forty-eight hours; this aggravates the thirst, sometimes almost to torture. If there be special reasons for withholding liquids by the mouth, a pint of hot water, administered slowly by the rectum, will relieve the thirst; and a second administration, after six hours, will probably remove it. But in ordinary cases liquids may be given by the mouth almost from the beginning. Most women prefer hot tea made to their own taste, and with it a little dry toast may be given. Gruel, one of the ordinary children's foods such as Benger's or Mellin's, barley water or toast water, or almost anything the patient likes, except milk, may be given by the mouth. On the second day home-made beef tea, or any of the concentrated beef essences, may be given, well diluted. Often on the third, nearly always on the fourth day, the patient may be permitted to order her own diet. After the fourth day solid or concentrated foods are preferable to liquid and very dilute foods; they produce less flatulence, and are usually liked better. Fish, chicken, game, boiled or stewed, and not roasted, may be given on the fourth day; and thereafter the diet scarcely requires regulation. Fruit of all sorts may be given throughout. Milk is not a good food after abdominal operations; it causes flatulence and promotes constipation, or rather permits it.

The functions of the bladder require special attention. It used to be the custom to draw the urine off by catheter at regular and stated intervals after operation, whether the patient desired it or not. This is not necessary. As a rule the catheter need not be passed till the patient desires to micturate, and then, if she can, she may be permitted to do so. It is rarely necessary to interfere during the first twenty-four hours. The amount of urine secreted is diminished considerably after ovariectomy, and remains under the normal for about a week. On the first day about 15 ounces, on the second 20, on the third 26 may be expected. Therefore, if the patient cannot herself micturate, one passing of the catheter on the first day, two on the second, and three on the third and subsequent days, should suffice; unless there be a desire for relief on the part of the patient. To avoid catheter-cystitis strict attention should be given to the purification of the orifice of the urethra and of the catheter. A metal catheter, which can be sterilised by boiling or heat, is safer than a catheter of soft material which cannot be so treated. Catheter-cystitis, which is simply septic cystitis, may be very troublesome, lasting over weeks; therefore, strict personal attention should be given to this item in the treatment.

At the end of the second or third day the bowels should be evacuated. Ordinarily this is best secured by a soap and turpentine enema. Usually great quantities of gas come away with the enema, and the abdomen becomes flat or concave. A seidlitz powder, given the first thing in the morning of the third day, if the patient can take it, will have an equally good, or even a better effect, if it acts; but it is some-

what uncertain. On the third or fourth day an active purge of colocynth may be administered. Thereafter the bowels are kept acting by any means the surgeon considers suitable.

These remarks refer to the ordinary progress of an uncomplicated case. A serious operation is followed by a serious illness of the kind which follows all grave operations, and it is treated on the same principles. Such an illness, classed under the broad term "shock," is soon over. Specially dogging the graver operations, but also sometimes following ordinary ones, is a complication of troubles which are often classed vaguely as peritonitis, and which present themselves as abdominal distension, obstruction of intestines, and vomiting.

Severe shock or collapse after operation is combated by the application of heat to the body surface; by elevation and bandaging of the limbs; by hypodermic injections of ether; and by rectal injections containing brandy. Irrigation of the cavity with water heated to 105° or 110° F. has been spoken highly of as treatment of shock. Near the end of a bad operation it is good practice to administer a four-ounce rectal injection, containing an ounce of brandy; and to repeat this every four hours till the patient is out of danger. Hypodermic injections of strychnine are spoken highly of by some surgeons, not only as helping to prevent shock, but also as causing contraction of the intestines. Morphine is not to be administered except in cases of great restlessness or jactitation; then it is of real value. The objections to it are the gaseous distension of the intestines, and, in some patients, the nausea and vomiting which it produces. After every serious operation it is wise to begin rectal feeding at once, and this should be continued until the patient, without losing ground, can get on with nourishment taken by the mouth.

The condition which is most dreaded after ovariectomy has been vaguely, perhaps inaccurately, but conveniently described as originating in peritonitis. The exact pathology of the condition is not ascertained; probably it has several causes, not one of which may be peritonitis. It manifests itself by three almost uniform signs—vomiting, abdominal distension, and constipation. Whatever be the prime cause, our only means of curing the disease is by fighting the symptoms.

Extensive and serious injury to the peritoneum is probably followed by peritonitis. A traumatic peritonitis, with abundant exudates, provides a convenient medium for septic invasion. Thus, though it practically happens that septic peritonitis is chiefly associated with traumatic peritonitis, they are not necessarily connected; the one may exist without the other. If the patient gets well we cannot say whether it has been septic or traumatic; it may have been both. After death the difficulty is little less; post-mortem peritoneal fluids are culture media for all contiguous intestinal germs, and their presence in peritoneal exudates after death is no certain proof of their presence during life.

As yet we can only treat the disease by meeting its manifestations.

The first symptom we have to deal with is vomiting. Arising after

recovery from the anæsthetic, and continuing over the first day or two, it may be nothing more than anæsthetic sickness; continuing over the third or fourth day, or beginning on the third and continuing, it means something more, and is of grave moment. It is useless to seek to control it, nor is it wise to attempt to do so. Vomiting relieves over-distended intestines, and should be encouraged rather than repressed. The stomach should not be worried with food; this simply adds to the labour of rejection: none of it is absorbed.

As soon as vomiting has set in the patient should be fed entirely on stimulating enemas. A good routine enema is an ounce of brandy, two drachms of concentrated beef jelly, and milk, peptonised or not, up to four ounces. Not much milk is absorbed, but it acts as a diluent, and is well tolerated by the rectum. Once in the day, at least, a large turpentine enema should be given; it will bring away quantities of gas and unabsorbed and putrefying residues of food, and will cleanse the large bowel: the turpentine has probably some antiseptic influence as well. Constant vomiting of small quantities is very exhausting to the patient, and is often associated with over-distension of the stomach; in such a case it is often good treatment to pass the stomach-tube and empty the stomach. If the stomach be not over-distended, but vomiting frequent, it may do good to give a large drink of soda-water, so as to encourage one attack of free vomiting. A period of rest often follows such treatment.

Usually associated with the vomiting is tympanitic distension of the intestines. The condition is well named "Pseudo-ileus." It is a form of intestinal obstruction without a mechanical, or at any rate a constricting cause. The influences at work in the production of pseudo-ileus are probably varied; certainly one of them is a condition of intestinal paresis whereby stasis of intestinal contents is produced. If we can overcome this condition, if we can make the intestines act, we shall probably cure the patient. This has been written and spoken of as the treatment of peritonitis by purgatives, and many arguments have been used for and against the treatment. It is probably not so much the peritonitis as the parietic ileus which is attacked and cured by purgation. When the latter is removed the former cures itself. It is certain that a sharp purge will often put a completely new aspect on a case which is drifting hopelessly on to death with tympanitic distension and vomiting. Enormous quantities of gas and fluid fæces are passed; the abdomen, before distended and brawny, becomes flat and soft; vomiting ceases; and the patient expresses a sense of relief which usually culminates in refreshing sleep. There is probably no single effect of a drug in the whole of surgical practice more strikingly beneficent than this one of a purge in operation-ileus. For mild cases a seidlitz powder will usually suffice. For more severe cases a full dose of colocynth and jalap, or a calomel powder may be given. The treatment of the full consequences may well be carried into the beginnings of the trouble. In other words, we may wisely keep the bowels acting almost from the beginning. If the routine turpentine enema fail to keep the abdomen flat a purgative should at

once be given by the mouth; and this should be repeated once or twice while there is any marked tendency to distension.

An invaluable adjuvant in the treatment of flatulent distension is the passing and wearing of the rectum tube. The vaginal tube which accompanies a Higginson's syringe does very well for the purpose, and is a good model as regards size and length for any specially made tube. It is best used with the patient on her side, and the hips raised so that the gases rise to it. The intestines contract at intervals; the large bowel may be emptied in the first few seconds; then after a minute or two more gas comes into it from the small intestines, and is passed; then after another interval more gas is passed, and so on till the abdomen becomes flat. It is a good plan to let the patient wear the rectum tube for half an hour before the enema is due, to pass the enema up the tube, and then to remove it. A skilled nurse will be able, by judicious introduction of the rectum tube, to render most important assistance in the recovery of the patient.

The pyrexia which follows ovariectomy scarcely ever requires treatment. In simple cases there is usually a rise to  $99.5^{\circ}$  or  $100^{\circ}$  F. on the second day, and this usually falls to normal on the third or fourth day. In bad cases there is rarely any rise at all; in the worst cases, and especially those with septic peritonitis, the temperature is usually sub-normal till just before death, when it rapidly rises. So rare is a dangerous rise of temperature that no provision need be made to deal with it.

Rare and special complications scarcely require mention. The most common of them is parotitis. Mania occurs in a very small proportion of cases. Intestinal fistula caused by injury to bowel at the operation, or by pressure from a drainage tube, may spontaneously heal, or may require operation. The occurrence of ventral hernia as a late result should be very rare in ovariectomy if the closure of the parietal wound is skilfully effected. Its treatment is outside the scope of this paper.

**Removal of the Uterine Appendages (Oophorectomy: Salpingo-Oophorectomy).** — By this operation is meant removal both of ovaries and Fallopian tubes for disease other than neoplasm. The operation may be undertaken: I. When the appendages and the uterus are normal; II. When the uterus is affected with myoma; III. When the appendages are in a state of inflammation. Variations in the method are described under these headings. A short account of conservative operations on the ovaries and tubes is added.

The operation is prepared for as in ovariectomy; and all details as to room, assistance, anaesthesia, and nursing are identical. The Trendelenburg posture is much preferred by some surgeons for this operation.

The instruments also are the same, except that tapping trocars and numerous large cyst-forceps are not called for. Two pairs of large elbowed pressure-forceps and a dozen ordinary catch-forceps are necessary. In cases where the appendages are bound down by numerous and firm adhesions in Douglas' pouch, the rectal bag, as used in supra-pubic cystot-



omy, may be found very useful for raising the field of operation nearer to sight and touch.

*Operation with Appendages and Uterus Normal.* — The incision, which need not be longer than an inch and a half or two inches, is made in the middle line a little nearer to the pubes than to the umbilicus. The tissues divided are the same as in ovariectomy. As, however, the parietes are not stretched by tumour, the linea alba is narrow; and one or other rectal sheath will probably be entered. The peritoneum when exposed is picked up between two peritoneal catch-forceps and pulled forwards; the fold between them is sawed through by a knife held horizontally; air rushes in when the cavity is opened, and the bowels fall back. The left forefinger inserted through the opening serves as a guide on which to divide with scissors the peritoneum to the whole extent of the parietal wound.

The first and second fingers of the left hand are now inserted into the cavity, and are carried straight down to the pelvis. It may be necessary to push omentum upwards. The fingers, displacing intestines which are in the way, seek for the fundus uteri, and grasping the fundus between them, they are slipped along one or other broad ligament, gathering Fallopian tube and ovary in their grasp, and holding them there. These are now lifted out through the parietal wound, and arranged for application of the ligature. The parts to be removed are the ovary, with its mesovarium, and the Fallopian tube in its outer three-fourths, with its double fold of peritoneum or mesentery; in which also lie the parovarium and the vascular tissue known as the bulb of the ovary.

The ligature is placed by transfixion. The Staffordshire knot is perfectly satisfactory and easily applied. The pedicle-forceps (Fig. 232) is passed through the broad ligament under the ovary at the point selected, and catches the loop of silk ligature, placing it in withdrawal. Or the ligature may be passed threaded in a blunt needle. The loops being arranged as already described for ovariectomy (p. 889), the fingers of the left hand pull ovary and tube well through them, while the ends are pulled as tightly as possible by the right hand. Pressure between the left finger and thumb around the seat of ligation, combined with traction on the ends of the ligature, serve to bury the ligature in the tissues; then it is tightly tied in the usual way. Forceps or the fingers of an assistant are quite unnecessary; the whole may be done in a few seconds by the surgeon unaided. The parts are then cut away by scissors at a distance of about one-third of an inch from the ligature. Before division is complete a catch-forceps may be placed on the stump to make certain, by pulling it to the surface, that hæmostasis is perfect before closing the wound. The same steps are carried out with the appendages on the opposite side.

Then a small sponge is placed under the parietal opening, the sutures are inserted, the sponge is removed, the stumps are pulled up by their attached forceps, looked at, and if well secured, are dropped into the

cavity, and the sutures in the parietal wound are tied. The wound is dressed as in ovariectomy.

*Operation for Uterine Myoma.*—In the case of small tumours the operation may be the same as that just described with normal uterus.

Where the tumour is large or fixed in the pelvis, or where, being in the fundus, it grows away from the appendages, the operation may present considerable difficulties, or may even be surgically impossible. In unsymmetrical tumours one ovary may be near to the surface and quite within reach, while the other lies deeply or out of reach. In all cases, therefore, before removing the appendages on one side we should ascertain if the appendages on both sides can be removed. It frequently happens that an ovary is much stretched, and so attenuated as to be almost undiscoverable; sometimes it is almost buried in the sulcus between two growths.

When it has been decided to remove the appendages, the tumour is turned to one side so as to bring them as close to the surface as possible. At this stage it may be advisable to prolong the incision upwards or downwards as may seem more convenient. In most cases the incision will have been made longer than for cases with normal uterus. If possible the Staffordshire knot is used: but, if the ovary be much spread out, a double or triple interlocking ligature may be preferred, as it is possible thus to get more thorough constriction over a larger area. Forceps are left attached to the pedicle first made while the uterus is turned to the opposite side, and the alternate appendages are removed. A sponge placed over the pedicle prevents disturbance by friction, and calls attention to the existence of bleeding.

It would seem that intestinal obstruction from adhesion of bowel to stump, and consequent kinking, is more liable to follow removal of the appendages for myoma than for other disease. The intestine seems liable to get caught between tumour and pelvic wall, or at least does not freely move about there; and thus the formation of adhesions is favoured. To avoid this, the stump may be turned face-inwards on the tumour, and held there by a stitch; its raw surface then becomes adherent to the tumour: or it may be covered up by a flap of peritoneum left hanging beyond the actual line of division.

*Operation with Appendages inflamed and adherent.*—Removal of the uterine appendages, when matted together and adherent to neighbouring organs, and perhaps containing one or more collections of pus, may be a very difficult operation. A good many cases are recorded where the operation was either abandoned as impracticable or was left incompleted.

The operation is performed either by the help of sight or by touch alone without exposure to view. If the diseased organs are to be exposed to view, a long incision and either evisceration of intestines, or pushing them into the upper abdomen, are necessary. For this the Trendelenburg posture with great elevation of the pelvis should be adopted. The use of the rectal bag to raise the pelvic floor is also of assistance. Strong retractors, or Maunsell's self-acting retractor, are

necessary to keep the parietal incision open; and artificial light with or without concave mirrors may be required.

This method of operating has not found favour in England. If the parietes are muscular and hard, it is not easy to crowd the intestines into the upper abdomen; and considerable force may be required to keep the incision sufficiently open to give a fair view of the parts while manipulation is going on. The incision itself must be of considerable length, five or six inches perhaps; and this means in an undistended abdomen that it reaches the umbilicus, or even rises above it.

It is best to depend entirely on the fingers for removal of adherent appendages. The skilled sense of touch is a safe guide against the risk of tearing bowel or other attached structures, and the fingers are strong enough to detach any adhesions which are likely to be met with.

The incision is made in the ordinary way, and may be about three inches in length. A little cloudy or pink serum often appears in the incision; not unfrequently there is a considerable amount of ascites. The first and second fingers of the left hand are carried to the fundus uteri, thence into Douglas' pouch, and along both broad ligaments; and the state of affairs accurately made out. If there be any collections of fluid, purulent or sanguineous, it is wise at once to place a flat sponge in the pelvis to prevent contamination in case the cyst-wall is ruptured. It is often almost impossible to separate and deliver entire an abscess with very thin walls; a sponge to surround the field of operation minimises the risks from rupture and diffusion.

The work of separation is now begun. Detachment is begun from below, the inflamed organs being unfolded upwards as the adhesions are separated. The firmest adhesions are usually to the posterior surface of the broad ligaments, and here bleeding is likely to be most free. Adhesions to the rectum must be separated with great care to avoid laceration of the wall of the bowel.

The presence of the rectum bag moderately distending the gut guides the finger in its movements, and helps to give some idea of the thickness of its wall from which the organs are being detached. Adhesions to the uterus are more easily managed, although the bared surface may bleed freely. Into the spaces made after detachment the sponge is dragged, or new sponges are placed. This sponge-packing is a measure of safety in case of extravasation, a guide to a source of bleeding, and an absorbent of blood. It is also useful as a hæmostatic.

When the organs are detached they are pulled to the surface through the wound. Often they are quite sessile on the broad ligament, and some force may be necessary to bring them within sight. Such force is exerted not by dragging on the organs themselves but on their pedicle held between the two fingers. Liberation may be assisted by pushing down the broad ligament at its pelvic attachment; tearing or stretching its fibres, but not wounding its peritoneal envelopment.

Frequently the pedicle must be tied at some distance from the surface. By depressing the parietes and pulling the organs well up into the wound



this may usually be done within sight, but sometimes the pedicle must be tied and divided entirely by touch. The ligature is placed by transfixion and tied, as already described, either in a Staffordshire knot or in interlocking ligatures. The organs on the other side are detached and removed in the same way.

Bleeding in these cases is sometimes very free, and occasionally alarming. By sponge-packing and pressure it may usually be checked in a few moments, and no bleeding points require forcipressure or ligation. If it continue, bleeding points should be looked for through a Fergusson's vaginal speculum; or, if this means fail, the wound must be enlarged and the pelvic floor exposed. The Trendelenburg position is here of some advantage. A solution of iodine or of perchloride of iron may be mopped over a bleeding surface, or the actual cautery may be applied. Bleeding points are caught in forceps, which are left on for a few moments while the cavity is cleansed and the sutures are placed. Forceps placed on the rectum may, if too large a hold has been taken, result in the formation of a slough followed by fistula.

The pelvis should be carefully cleansed by sponging or irrigation, or both, according to the nature and amount of extravasation. Sponging will usually suffice if blood only has to be removed; indeed most of the blood will be removed with the sponges which have been packed into the wounded areas. Irrigation must be employed if fluids of a putrid or doubtful nature have escaped.

Drainage is advisable in most of these cases. Through the tube bleeding gives timely warning of its onset; and through it the abdomen can be kept dry, which in itself favours clotting and hæmostasis. In cases of free bleeding the use of the gauze drain, or of gauze-packing, may be necessary. But everything possible should be done to render hæmostasis perfect by the ordinary surgical means before having recourse to such uncertain methods as these.

Keith's glass drainage-tube with open extremities is usually the best. The tube should reach to the bottom of Douglas' pouch, and should be supported by the collar outside the wound, and not by the rectum. Pressure on the rectum by the tube may cause the production of intestinal fistula. Gauze or thread capillary drains are placed inside the tube, and the absorbent dressing is placed over the tube enclosed in a folded sheet of india-rubber through which the upper end of the tube is drawn. The drainage-tube in most cases may be removed in a day or two; but some cases require drainage for a week or even longer.

Where there is a large pyosalpinx or ovarian abscess it is generally advisable to empty the fluid by aspiration before beginning to separate adhesions. This diminishes risk from escape of fluid, but adds to the difficulty of separation by fingers.

The wound is dressed and the patient is treated exactly as after ovariectomy. Usually there is more pain than after ovariectomy, and constitutional disturbance with rise of temperature may be more marked. Pain severe enough to cause great restlessness or jactitation may be



alleviated by a hypodermic injection of morphia; but the recovery is nearly always more rapid and satisfactory if morphia is withheld. Metrorrhagia nearly always comes on after one or two days; this gives relief and requires no treatment.

**Conservative Operations on the Ovaries and Tubes.**—Till the last few years the generally expressed opinion of the most experienced operators—that it is best to remove diseased ovaries and tubes completely—has been received and acted upon. A few surgeons have recently maintained, and proved by records of successful cases, that destructive surgery is not always necessary for cure; but that conservative operations, leaving the organs or some part of them intact, may be followed by cure. This has been maintained in respect not only of inflammatory conditions and hernia, but also of tumours and cysts.

In respect of tumours, Martin of Berlin, Sippel, and Pozzi have been the chief advocates of conservatism. If, near the hilum, a portion of healthy ovarian tissue be visible, this is left, and the incised surfaces are apposed and fixed by sutures. Pregnancy resulted in a case of Sippel's where one ovary affected with a small growth was so treated; the other ovary being completely removed for a large growth. Martin, in twenty-seven cases in which portions of healthy ovary were left, had one death and two relapses; eight of the patients bore children afterwards. Pozzi, in twelve cases of resection of the diseased portion alone, speaks favourably of the operation. Other surgeons have mentioned cases, but have been cautious in drawing conclusions.

In cases of simple cysts treatment by simple puncture, or by removing the whole of the cyst-walls by scissors, is undoubtedly sound. Most surgeons would probably agree in this practice.

In the case of abscess there is more room for dispute. Simple evacuation of the abscess with cleansing of the abscess wall would, in carefully selected cases, probably be entirely satisfactory. One difficulty is to be certain that the abscess is single, for abscesses in glandular organs are liable to be multiple; and another is to be certain that the abscess wall is rendered sterile. Drainage, except in large abscesses, is not feasible at a distance from the surface; and if it were so employed it would leave the organ in a bed of adhesions which would probably beget chronic invalidism of another sort. The most satisfactory results would be in a peripheral abscess with comparatively thin walls, where the whole sac might be cut away, and the cavity left might, after purification, be closed up by sutures. A central abscess with general distension of the whole ovarian tissue could scarcely so be treated, and is probably best treated by removal of the whole organ. There is, theoretically, no need to remove a healthy Fallopian tube with a suppurating ovary; but experience proves that healthy tubes with suppurating ovaries are the rarest of combinations. The tube is useless without its ovary; the ligature of the ovarian pedicle will probably cause injury or kinking of the tube; therefore, if the ovary be removed, it is usually safer for recovery from the

operation, and for the future comfort of the patient, to remove the tube also.

The removal of the appendages on one side only for suppurative disease was tried by Tait, but given up on account of the large number of recurrences or relapses. Other surgeons have had similar experiences; and the rule in all cases of suppurative disease of the appendages now is that if one set is removed so also should be the other.

More promising results have been got in the conservative treatment of chronic inflammatory disease with adhesions, but without suppuration. Liberation of the organs with removal of long tags of adhesions and perhaps puncture of cysts may result in cure. In most of such cases there is prolapse; to remedy this operative elevation of the ovary on the broad ligament by shortening its mesentery has been practised. Of the real and permanent value of oophoraphy or oophoropexy published records do not permit us to judge; but there can be no doubt of the advantage of the liberation of an ovary bound down by adhesions in Douglas' pouch or elsewhere.

Hernia of the appendages into the inguinal or femoral canals may, even if strangulated, be properly treated by return into the cavity of the abdomen, provided the hernial openings be closed. Tubo-ovarian herniæ are nearly always inguinal; tubal hernia is with about equal frequency femoral and inguinal. A strangulated tube is not unlikely to contain one or several collections of pus; its return, therefore, should be carried out only after minute examination. A probe may be passed along it, or puncture or other means adopted to make certain of the absence of suppuration. For most cases of strangulation of tubes operation by removal is generally considered most satisfactory. The method of radical cure of the hernia to be adopted need not be described.

Tubercular disease of the tubes should always be treated by complete removal.

Simple cysts of the Fallopian tubes may be cured by incision, with partial removal of the cyst-walls. But in respect of restoration of function, such an operation has no advantages over complete removal, and has evident disadvantages in the possibility of recurrence with stenosis of the tube.

J. GREIG SMITH.

#### REFERENCES

1. CHAMBON. *Des maladies des femmes*, Paris, 1784; and *De l'extirpation des ovaïres*. Paris, 1798.—2. CLAY. *Cases of Peritoneal Section for Extirpation of Diseased Ovaries*. Lond. 1842.—3. DELAPORTE. *Mém. de l'Acad. Roy. de Chir.* Paris, 1753.—4. HUNTER. *Med. Observations Inquiries*, vol. ii. Lond. 1762.—5. KELLY, HOWARD. *Amer. Jour. Obstet.* xxiv. 12, 1890.—6. KING and JEAFFRESON. *Lancet*, Lond. 1856-7, i. 588-590.—7. M'DOWELL, E. "Three Cases of Extirpation of Diseased Ovaria," *Eclect. Report*, Phila. 1817, vii. 242-244. (From Index-Catalogue of Library of Surgeon-General's office, Washington.)—8. MARTIN. *Deutsch. med. Woch.* July 27, 1893.—9. POZZI. *Ann. de gyn. et d'obstét.* March 1893.—10. SIPPEL. *Centrabl. f. Gynäk.* iii. 1893.—11. TAIT, LAWSON. *Diseases of the Ovaries*, 4th ed. Birm. 1883.—12. WELLS, Sir SPENCER. *Diseases of the Ovaries*, Lond. 1872; *Abdominal Tumours*. 7th ed. Lond. 1887.—13. WILLIUS. *Stupendus abdominis Tumour*. Basil, 1731.

Special Works and Articles on Ovariectomy.—1. ATLEE, W. S. *Diagnosis of Ovarian Tumours*. Phila. 1873.—2. BAKER-BROWN. *On Ovarian Dropsy*. Lond. 1862.—3. CLAY. *Cases of Peritoneal Section for Extirpation of Diseased Ovaries*. Lond. 1842.—4. COURTY, A. *Diseases of the Uterus, Ovaries, and Fallopian Tubes*. Trans. from 3rd edit. by A. M'Laren. Lond. 1882.—5. DORAN, A. H. G. *Tumours of the Ovary, Fallopian Tube, and Broad Ligament*. Lond. 1881.—6. *Ibid.* *Gynæcological Operations*. Lond. 1887.—7. KEITH, SKENE and G. E. *Abdominal Surgery*. Edin. 1894.—8. KOEBERLÉ. *Sur le traitement des kystes de l'ovaire*. Paris 1865.—9. *Ibid.* *Manuel opératoire de l'ovariotomie*. Paris, 1870.—10. LIZARS, J. *Observations on Extraction of Diseased Ovaria*. Edin. 1825.—11. PÉAN, J. *Tumeurs de l'abdomen et du bassin*. Paris, 1895.—12. PEASLEE. *Ovarian Tumours*. New York, 1872.—13. SMITH, J. GREIG. *Abdominal Surgery*, 5th ed. Lond. 1896.—14. SUTTON, J. BLAND. *Surgical Diseases of the Ovaries and Fallopian Tubes*. Lond. 1896.—15. TAIT, LAWSON. *Diseases of the Ovaries*, 4th ed. Birm. 1883.—16. WELLS, Sir SPENCER. *Diseases of the Ovaries*. Lond. 1872.—17. *Ibid.* *Abdominal Tumours*, 7th ed. Lond. 1887.

1. *System of Gynæcology and Obstetrics by American Authors*. Edited by M. D. Mann and B. C. Hirst. "Gynæcology." Edin. 1889, ii. 189 *et seq.*—2. *An American Text-Book of Gynæcology*. Ed. by J. M. Baldy. Phila. 1894, pp. 594-600.—3. *Clinical Gynæcology by American Teachers*. Edited by J. M. Keating and H. C. Coe. Edin. 1895, p. 697 *et seq.*—4. *Pepper's Syst. Pract. Med.* "Dis. of Ovaries and Oviducts" (Skene), 1886, vol. iv.—5. *International Encyc. Surg.* Ed. by Ashurst, Lee, 1886, vol. vi.

J. G. S.

## CHRONIC INVERSION OF THE UTERUS

INVERSION of the uterus has been a favourite theme for essays. It is a condition attended with considerable anxiety, impaired health, and danger to life. Its occurrence is far from common: eminent consultants of exceptional experience have never met with it; practitioners engaged in large midwifery practice have never seen a case. It was found at the Rotunda Hospital once in 190,800 deliveries. At the Vienna Lying-in Hospital 250,000 births occurred without a single instance. With access to records of over 20,000 labours I have met with one case of recent inversion; and in twenty-five years' practice two instances only of chronic inversion have come under my own care. Possibly it has happened without recognition, or at any rate without publication, where close inquiry was not practicable.

Inversion, as the name implies, is the uterus turned inside out; the lining mucous membrane becomes external, the serous peritoneal membrane internal.

It may be puerperal or non-puerperal: in the former it is associated with labour or is the result of pregnancy; in the latter it is allied with certain tumours or growths in the non-pregnant uterus. The puerperal condition is responsible for the great majority of cases, as many as 87·5 per cent. Most of these happen at or near the termination of labour. Of the 224 cases collected by Crampton, 196 are noted as having occurred at once; that is, at the end of the process of confinement. It follows

that a division into acute and chronic is admissible, the distinction being based upon the completion of the involution of the uterus; that is, about six weeks from the date of labour.

In the puerperal variety, therefore, inversion of the uterus may be looked upon as chronic when it persists after the regenerative changes which are normally effected after delivery. The usual reconstitution of the uterus may be retarded or perverted by the conditions present in any given case; but the interval of time forms a valid ground for definition and for treatment. Chronic inversion is a sequence, then, of the acute form; and is due to failure of reduction before the time allowed for reparation of the puerperal uterus. Chronic inversion further includes cases occurring independently of pregnancy; those which happen as a complication of some tumours, or of some growths in the uterine walls, malignant or otherwise.

**Anatomy and Pathology.** — Various degrees of inversion are described. According to Crosse, partial inversion in its slightest degree is present when any portion of the entire thickness of the walls of the uterus becomes convex towards its cavity or interior; although it may not be invaginated, or brought within the grasp of the rest of the uterus. It may accompany the projection of a tumour into the cavity; thus the peritoneal space has been opened in dividing the base of a tumour for its removal. One horn of the uterus may occasionally be indented. In cases of post-partum hæmorrhage, with a large and flabby uterus — especially where efforts are made by external pressure to force the uterus into contraction — we not infrequently find the wall to yield and partial depression to follow. This is more likely to occur when the hand is pressed against the uterus, instead of grasping it after the method of Crédé. In this way, as the placenta is expelled, the fingers may pursue it into a hollow, which the contraction of the whole uterus generally readjusts at once.

The body of the uterus may be inverted as far as the os internum; or there may be complete inversion of the body through the cervix into the vagina, or even externally. Generally the cervix remains, forming a distinct fold or ridge around the neck of the inversion. This fold varies in depth according to the extent in which the cervix is involved. As a rule it is rather deeper in front than behind. When the uterus descends externally it is usually accompanied by inversion of the vagina; the cervix also participates, and the depression formed by the ring may not be found.

The form of the inverted uterus is round or pear-shaped, with a well-formed but smaller base. The shape varies somewhat according to the degree of inversion and the pressure to which it is subjected by the constricting ring of the cervix; or, when lower down, by the opposing contact of the vaginal walls.

The same circumstances affect the consistence and colour. It may be firm and tense, softer and more yielding, smoother and more velvety to the touch. The surface of the mucous membrane may be red, or congested and purple; usually it is less pink than that of the fibroid. It may



present ecchymosed spots, or show erosions and ulcerations which, in few instances, have formed adhesions to opposite surfaces of the cervix of vaginal walls. It bleeds freely when handled. When the inverted surface is exposed for any length of time to the air the mucous membrane may lose its normal characteristics, and become dry and wrinkled like that of a procident vagina. The two have indeed been confounded.

Inflammation and even gangrene have followed the arrest of blood-supply and the perverted nutrition due to the incarceration; and in some rare instances sloughing of the inverted portion has taken place.

The peritoneal invagination contains, at the beginning,<sup>1</sup> the broad and round ligaments, the Fallopian tubes, and the ovaries. Sometimes, at the first rush, a loop of small intestine is drawn into the cavity. After a time, when contraction takes place, the ovaries and tubes recede outside the space; and the margin of the opening remains as a firm ring into which the finger can hardly pass. It rarely happens that any adhesion takes place between the peritoneal surfaces, though this has occurred.

In cases of non-puerperal origin, when the formation of the inversion is more gradual, part only of the Fallopian tubes and broad ligaments are found in the interior space.

**Mechanism of Production.**—Inversion begins generally at the fundus; occasionally at the sides, posteriorly, or at the cervix.

It has long been considered that enlargement of the uterine cavity, associated with some cause capable of exciting contraction of its fibres, are the two conditions essential to inversion. That the uterus often contracts irregularly, one part being firm, another relaxed, is well known. The state spoken of as polarity, when the fundus is contracted and the cervix dilated, or conversely, is an observed fact supposed to be due to some correlation of nerve force.

Most authors speak of the important part taken by modifications in the placental site as a factor causing inversion. The wall of the uterus at this part is thinner and more lax; its structure is modified; it is generally more yielding and of less power. Klob says defective contraction of that part of the uterine wall which forms the placental insertion is of extraordinary importance; and he describes it as sinking inward into the uterine cavity while other parts of the organ seem tolerably well contracted.

Rokitansky speaks of paralysis of the placental insertion as originating depressions in connection with irregular contractions of the other parts of the uterus.

Matthews Duncan devoted special attention to this subject, and formulated his views respecting it with much emphasis. His views appear to be the outcome of a concise and logical interpretation of facts which afford a rational explanation of the phenomena observed. He divides inversion after delivery into active and passive, and describes four kinds: (A.) *Passive*: (i.) *Spontaneous*, and (ii.) *Artificial*. (B.) *Active*: (iii.) *Spontane-*

<sup>1</sup> Svensson amputated one three months after delivery, and found in the extirpated mass both the ovaries and the greater portion of the broad ligament (Sajous, 1889, i. p. 23).

*ous, and (iv.) Artificial.* The condition, he says, essential to the production of all these kinds, and the only one, is paralysis or inertia, or complete inaction. Such is the condition of the whole organ at the time of production of the first two kinds: in the last two kinds the accident is accompanied by uterine activity, but, as these cannot exist in the same part, the paralysis is partial, and the activity is partial. He affirms that activity of the whole of the uterus, or of its body, renders inversion impossible.

Force may be applied from above to push the paralysed wall into the uterine cavity; or from below to pull it into the cavity. In the spontaneous kinds it is to be found in the mechanical conditions of the abdomen, in the ordinary down-bearing effort, or in the absence of the retentive power of the cavity however produced. In connection with the artificial kinds I may refer to cases where the cause is to be found in pulling upon the cord — “manœuvring with the placenta,” as Matthews Duncan aptly terms it. No doubt when the attachment of the placenta is to the fundus, the disposition to inversion is aggravated by traction.

On the whole, it may be considered that traction of the cord as a cause of this accident is overrated, especially in modern times when better knowledge commands more accurate management of the third stage of labour. Shortness of the cord, whether in length or from coiling, has not the importance formerly attributed as a cause; unless indeed the labour be precipitate or the patient rapidly delivered in the upright position.

*Spontaneous active inversion* is probably the most common kind: paralysis of a portion of the fundus or placental portion leads to the depression; the paralysed projecting part is further seized, pushed down, and expelled by the contracting parts through the os uteri or into the vagina.

That inversion may begin at the cervix has been clearly demonstrated by Dr. Taylor of New York in a case of his own; in that of Reeve and others the condition began by eversion of the os, and rolling of the body and fundus out of the cervix.

Dr. Duncan admits that, under powerful contraction of the fundus and relaxation below that part, inversion of the lower part of the cervix may occur alone; and he says that it is not rarely observed after delivery. He depicts diagrammatically the extent to which the change may go in the direction of inversion; but does not say that he has seen it occur in the complete degree observed by Dr. Taylor. That spontaneous inversion of the nulliparous uterus can take place has been strongly denied. The case recorded by Dr. Taylor is a clear instance in the proof of its occurrence; other instances recorded by careful and competent observers render it indisputable that such an event may happen.

**Etiology.** — In the first place the changes coincident with pregnancy and parturition undoubtedly have the largest share in disposing to this accident. By far the greater number of cases occur in primiparæ. In Crampton’s collection of cases 88 out of 176 were after first labours. It rarely happens in conjunction with abortion or miscarriage.

Conditions in some respects analogous to pregnancy also act, though much more rarely, as disposing causes.

Distension of the cavity and relaxation of the walls of the uterus are important factors in the event. Deficiency in muscular tone and irregular or imperfect contraction tend to favour its production.

In women of feeble and lymphatic constitution, more particularly after severe hæmorrhage when the uterus is limp and flaccid, the liability is greater. Some individual peculiarity is also exhibited in those women in whom inversion has taken place in successive confinements.

Inversion occurs after abortion, in rare cases; generally as the result of some applied force or accident.

In the presence of morbid growths affecting the structure of the uterus there is, as a rule, dilatation of the interior. This is likewise to be noted in the case of tumours growing inwards, more so when attached to the fundus. Of the 400 cases given by Crosse 50 are noted as connected with tumours. Pediculated fibroids are the most common; with these it may occur spontaneously; or again, after removal of an intra-uterine tumour with a broad attachment. Some alteration in the walls of the uterus at the site of the growth, contractions at the menstrual periods, and intra-abdominal pressure are the usual associations which cause the body to be projected through the cervix. In sarcoma this is more frequent: Dr. A. R. Simpson met with it in 4 cases out of 48. It rarely occurs with epithelial carcinoma. Dr. Barnes mentions two cases. Distension by fluids or retained secretions is more uniform and gradual; in the absence of any weakened spot or external force the tendency of the walls to give way is less localised.

**Symptoms.** — When this event occurs suddenly and completely in its puerperal form the symptoms are those of profound shock and collapse, accompanied by intense pain and hæmorrhage. The pain is fixed and persistent; the bleeding continuous and profuse. The absence of the uterus from its normal position will remove all doubt as to the nature of the accident.

In the partial form the symptoms are not so characteristic; indeed, unless a thorough examination be made at the time, the accident may escape observation.

In chronic inversion the symptoms are anæmia and impaired health; irregular hæmorrhages, often profuse; discharges; sometimes urinary troubles; local pain and discomfort; difficulty in walking. In this way women have been known to drag on a miserable existence for many years, and die ultimately of exhaustion, peritonitis, or septicæmia. In some instances, however, patients have reached advanced age without any discomfort and even without knowledge of their ailment; and others have suffered little more than inconvenience from the displacement. Such immunity has generally been in women who have passed the climacteric period.

**Diagnosis.** — In a simple case the diagnosis is easy. In complex cases definite diagnosis is sometimes attended with difficulties which even

accomplished experts have not been able to overcome. The history of the case should be carefully inquired into; it is suggestive, and of consequence in sifting the puerperal from the non-puerperal origin.

On examination a smooth pyriform or round tumour is felt in the vagina, or protruding through the cervix; it bleeds readily when handled. The cervical ring is often high up, and the fold of the cervix can be felt all round; if traction by a fillet or noose around the body be possible the fold can be made to disappear—a fact of some importance in differential diagnosis from polypus. The depth of the cervical depression depends upon the extent of the inversion, but the continuity can be traced round the base without any sign of an opening.

In the dorsal position, with two fingers in the rectum and the opposing hand placed over the hypogastrium, the body of the uterus is noted to be absent from the normal position, and the fingers of the hands can be made to meet. The two forefingers of opposite hands in the vagina and rectum respectively may also be made to approach each other over the inversion. The recognition of the peritoneal orifice of the inversion is of much importance when it can be felt through the rectum or through the abdominal wall.

A sound passed into the bladder, with the concavity turned backwards, can readily be met by a finger in the rectum above the inverted uterus. If the inversion can be brought to view by a speculum, or by sufficient traction, the colour may be seen, and possibly the openings of the Fallopian tubes made out.

The sensibility of the inverted uterus to puncture or pressure is not always a trustworthy sign; nor is its absence by any means pathognomonic. As pointed out by Newnham, on the one hand, the sensibility of the uterus may be diminished in the chronic stage of inversion; and on the other it may be increased in polypus by inflammatory action. Again, if a polypus be covered by a layer of uterine tissue the distinction, whether with regard to colour or sensibility, is less appreciable.

*Differential Diagnosis.*—When a polypoid tumour is present in the vagina its attachment can generally be reached, and a sound can be passed through the cervical opening into the uterus for some inches. Adhesion round the base rarely precludes this use of the sound. Bimanually, or by recto-abdominal touch, the body of the uterus can be defined in its usual position, or sometimes retroverted. It is between partial and chronic inversion and polypus that great difficulty in forming accurate conclusions is sometimes found. Velpeau, quoted by Simpson, says that there are cases in which doubt is the only rational opinion.

Numbers of cases are recorded, in the practice of experienced men, in which the inverted uterus, or one horn of the inverted uterus, has been operated upon by ligature or otherwise, for supposed polypus; and, conversely, in which polypoid tumours have been removed under the impression that the operator was dealing with an inverted uterus. With the progress of scientific knowledge and improved methods of exploration such mistakes ought to be few and far between.



The past history of the case, as I have said, is significant. In a case of polypus the distance the uterine sound can be made to pass is a trustworthy criterion.

The presence of the uterus in its normal position, and the absence of any trace of depression on bimanual examination, are the most valuable signs. If the tumour be sufficiently low for traction to be made upon it, the remnant of the cervical canal can be made to disappear in inversion; while in polypus the whole uterus with the attached tumour can be made to descend by the same means. The coexistence of the two conditions — polypus with partial inversion at the site of attachment to the uterus — presents still more treacherous ground for differential diagnosis. Here we must rely mainly upon the onset and progress of the symptoms, together with a thorough bimanual investigation.

The use of the uterine sound renders no aid in this instance; but possibly the depression or dimpling of the uterus may be felt by the combined use of the hands.

It would be justifiable in such cases to dilate the uterus and, under an anæsthetic, to examine the internal and external surfaces more exactly. The risk of such a proceeding would be warranted in the face of a greater evil, that of operative interference without precise knowledge of the actual conditions.

From prolapse of the uterus the diagnosis should be easily effected. The procident mass is wider above than below; at the lower end the orifice of the os uteri can be seen, and a sound passed into it. These facts will suffice for the purpose. Moreover, the sound passed through the urethra goes downward in prolapse, upward in inversion. Manipulation detects the body of the uterus and the elongated cervix, which in prolapse are readily movable; while examination by the rectum and recto-abdominally shows clearly the relative position of the parts. In old standing cases inversion is often attended with some degree of prolapse; when the descent is marked the vagina is involved and may be inverted also. In this event bladder troubles are considerably increased.

**Course and Results.** — In some rare instances there has been toleration of the malady for many years, after involution has taken place; and more particularly when the menopause has been passed.

Occasionally, as before stated, inversion has been present without the knowledge of the patient, though as a rule there is continuous suffering. In some very uncommon instances spontaneous reinversion takes place. Dr. Thomas collected twelve cases; another is reported by Kemarski; an additional one happened, under the care of Schultze, after the removal of a myoma from the fundus. In this case the reinversion began at the cervix and was fully effected in about ten days.

The usual course is one of discomfort, irregular hæmorrhage, septic symptoms, attacks of pelvic inflammation, and exhaustion and wasting of general strength, until reduction brings relief, or death supervenes. The general mortality is estimated by Crampton at 20 per cent. Thus 32 out of 120 recent cases died. Of 104 chronic cases 7 died.

Dr. Busey attributes a share of the mortality to incompetence and errors. He lays stress upon the disastrous results which have arisen from mistakes in diagnosis and treatment, and denounces the inexcusable blunders which have occurred even in cases under the care of the most renowned physicians in the profession.

However deplorable this may be, it must be remembered that advance in surgical art is largely experimental. The faults of one generation are the foundation of success in those which follow. There is no finality in knowledge; no monopoly in intelligence. The great surgeon Lisfranc, in speaking of this subject, observed that "when the polypus or inversion has only partially opened the os uteri we are assured that the diagnosis is impossible—authors do not even consider the case." From this aspect, surely, progress has been made, and though infallibility has not been reached knowledge has been gained. Light has shone through darkness. *Humanum est errare.*

**Treatment.**—The difficulties of reduction in chronic inversion of the uterus are exemplified by the infinite variety of methods employed or recommended by various authors. Their name is legion, for they are many. It must be granted that there is no one plan universally applicable. Every case must be treated upon its individual merits. Unsuccessful attempts by one method may be rewarded by success in another, or by a combination of methods.

The chief obstacles to reduction are the rigidity of the cervical ring, with, in recent cases, increase in the volume of the uterus; or in long-standing cases diminished size with firmness of the organ. Another difficulty is found in the mobility of the uterus and in the difficulty of obtaining adequate counter pressure to the force applied from below.

Peritoneal adhesions are not frequently met with; they are more often surmised than found. Experience shows that even when desired for the closing of the inner opening they are hard to produce artificially.

In the commonest form of inversion, as pointed out by Schultze, there are two rings of the uterine wall one within the other. If the reduction is begun by seeking first to press the fundus upward by indentation a third ring is produced, which obviously increases the difficulty, unless the cervical constriction be already dilated or dilatable. The proper method is to grasp the inverted body and to press it upwards, so that the cervix may be dilated, and be the first part to be reduced: thus we imitate the method by which spontaneous reinversion takes place.

Ingenuity has been shown in mechanical contrivances, skill and dexterity in shrewd adaptations, and exemplary patience in manual efforts. The records of many isolated cases have contained the germs of explanation and suggestive reasoning. From the special to the general the deduction is conclusive that steady, sustained, and elastic pressure is the treatment likely to be attended with the greatest amount of success and good ultimate results. There is apparently no limit to the time when it may be employed with benefit; in cases of many years' duration it is still applicable.

The principle of sustained pressure may be obtained by different means, the main object being to dilate the cervical ring and to restore first that part last inverted. Sustained pressure may be solid or elastic; with the hands, with instruments, or by a combination of elastic bands with appropriate instruments.

The treatment may be classified as follows:—

(i.) Reposition by hands: (a) Aided by incision (cervical, uterine, abdominal). (b) Aided by instruments. (ii.) Elastic sustained pressure: (iii.) Amputation; vaginal hysterectomy.

*Preliminary Treatment.*—In all cases some preparatory treatment is desirable. The patient for some days beforehand should be kept in bed, the diet regulated, and the bowels well moved. Free vaginal injections of hot water, followed by a lotion of mercuric perchloride (1 in 2000) should be used night and morning; the manipulating hands must be thoroughly cleansed.

In attempting manual reposition the patient should be placed in the lithotomy position at the edge of a level table. A Clover's crutch is used, and an anæsthetic must always be administered. The use of a Barnes' bag in the vagina for some days beforehand may make more room; and in some instances may even of itself effect reposition (Kroner). Gariel's air pessary has also been used with the same result.

Emmet's method is as follows: The hand is placed in the vagina, the fingers and thumb encircling the portion of the body close to the seat of inversion, the fundus resting in the palm of the hand. This portion of the body is firmly grasped and pushed upwards, and the fingers are then immediately separated to the utmost. At the same time the other hand is employed over the abdomen in the attempt to roll out the parts forming the ring, by sliding the abdominal parietes over its edge. As the transverse diameter of the cervix and os is increased by the outspread fingers the long diameter of the body becomes shortened. In one of Emmet's cases reduction was completed in three hours and fifty-five minutes. In another, after three hours' effort, the treatment was stopped for the time, and resumed a month later. Five hours, with change of operators, was spent on this occasion without success; but finally, a week after the latter attempt, the inverted uterus was completely reduced in twenty-seven minutes by the same method.

To aid fixation the uterus was drawn down to the vulva, and the edge of the cervix on each side seized with tenaculums, which frequently tore out. Aran recommended Museux's forceps or tenaculum hooks for this purpose; and Freund introduces broad silk ligatures at several points of the circumference, and thus forcibly drags down the vaginal portion while pressing the body upwards.

Noeggerath compresses the body of the uterus, opposite to each horn, by the thumb and finger; so as to indent it on one side or the other. When this can be effected the indented horn acts as a wedge which facilitates the passage of the remaining portion of the body. Marion Sims succeeded readily in pushing in this part of the uterine

wall after the body had entered the cervical ring — a method previously advocated by Kiwisch. It is stated by Dr. Thomas to be more applicable and possible at this stage of the process than at the beginning of the treatment.

Courty insists upon the necessity of keeping the cervix fixed with two fingers introduced into the rectum. The cervix is drawn down outside the vulva and held with Museux's forceps: the index and middle fingers of the left hand are introduced into the rectum, and by bending them forward the cervix is easily fixed through the rectal wall. With the right hand the uterus is pushed back into the vagina; the fundus, contained in the palm of the hand, being turned towards the pubes. With the thumb and index finger of the right hand pressure is exercised on the pedicle of the tumour, so as gradually to increase the depth of the utero-cervical groove. The first stage is accomplished by pushing the body of the uterus upwards as stated, while the neck is retained through the rectum; the second by compressing the fundus laterally, and by pressing the thumb into a horn of the uterus.

Tate's method is ingenious; it consists in fixing and dilating the neck by inserting two fingers of the right hand into the rectum, and the index finger of the left hand through the urethra, while pressure is made against both horns by the thumbs.

Many other plans have been proposed; some original, some based upon combination of known methods.

Watts of New York easily effected reduction in a case by the following plan: "The uterus is drawn down to the vaginal outlet, two fingers are placed in the rectum, one of these through the wall into the depression: the uterus is then pushed on to it from the vagina, the second finger is then added to the first, and when sufficient dilatation of the ring is ensured the uterus can be returned."

Barrier (9a) made pressure with both hands, pressing the thumb against the fundus, and the cervix against the sacrum for counter pressure.

Incision. — Sir James Simpson (73a) found that in forcible reposition the edges of the cervix were fissured or slit; he therefore suggested incision as an aid. Marion Sims also proposed the same method.

Dr. Barnes (*op. cit.* p. 741), writing in 1869, states that for twenty years he had taught in his lectures that the unyielding cervix may be divided by incisions carried into its substance from above downwards, at different points of its circumference; pressure then applied will cause it to yield easily. In one case this was accomplished successfully. The uterus was drawn down by a sling noose of tape, and three incisions were made, one on each side and one posteriorly. Still he recommends the use of this only after a trial of Tyler Smith's plan, and then with great caution. Subsequently he advises that two incisions only should be made, and that reinversion should be limited to elastic pressure.

Dr. Matthews Duncan treated one case by incision from the internal os to the middle of the body in front and behind, followed by application



of taxis for reduction — a plan fraught with considerable risk from hæmorrhage and septic infection.

Other cutting operations have also been proposed in conjunction with internal dilatation. Browne describes this method as follows: The inverted fundus is drawn outside by strong volsella forceps until the openings of the Fallopian tubes are seen. An incision an inch and a half long is then made posteriorly; through this a dilator is passed up into the cervix, and expanded until the tissues are felt to relax. The opening is then further stretched by hard rubber dilators; the incision is sutured, and the inversion reduced by manipulation. With the incision, stretching, and handling, it would seem that the patient is exposed to risks which make the operation hazardous, and hardly justifiable with the alternative of others which have stood the test of experience.

Somewhat similar is the practice of Küstner, which he thus describes in one case: Patient *æt.* 19, *prinip.* Four different replacement methods and colpeuryesis had been tried without success. In the dorso-gluteal position the part was drawn with volsella forceps firmly downwards, so that the inverted uterus lay in the vulva; Douglas' pouch was opened wide, and the index finger of the left hand was inserted into the inversion infundibulum. As the latter was free from adhesions, it was possible to get quite to the bottom of it and to bring the whole uterus easily in front of the vulva. Further reversion attempts were carried out so that through Douglas' pouch with the index and middle fingers of the left hand the inversion infundibulum could be fixed, and with the thumb of the same hand Küstner tried to invaginate the fundus uteri, but without success. Leaving the index finger of the left hand in the infundibulum, he cut longitudinally for a length of 2 cm. from the surface of the mucous membrane through the posterior wall of the uterus, exactly in the median line in the region of the inner os uteri. Then the reversion method previously employed was repeated, and success easily followed. The reverted uterus was firmly retroflexed; a longitudinal wound in the posterior wall of the uterus was drawn with a volsella forceps into the wound of Douglas' pouch, and the former sutured peritoneally by three deep and two superficial sutures; thereupon the wound in Douglas' pouch was also attached with five sutures to the posterior vaginal wall with the result of recovery without febrile reaction.

Incision through the Abdomen. — In 1869 Dr. Gaillard Thomas reported a case in which he carried out a novel plan and achieved a great success. The patient, twenty-three years old, had borne one child twenty-one months before. Fourteen determined and prolonged attempts by experienced and able men had failed to reduce the inversion. On the last of these attempts Dr. Thomas incised the site of the stricture, when a nearly fatal hæmorrhage followed. A week later the abdomen was opened in the median line, and the internal ring was dilated by specially made forceps. A rent was made in the anterior vaginal wall by the force used from below. The operation under ether lasted one hour, the actual replacement occupying twenty-seven minutes. The patient made a good

recovery. In a similar case under his care the replacement was easily effected, but the patient died from peritonitis forty-eight hours afterwards. This plan has been tried by others with indifferent success. The principle, however, is a rational one; and it is offered as a substitute for amputation of the uterus after all other means have been fairly tried. As such it must be regarded as a valuable contribution to the methods of treatment at our disposal; it is certainly not more difficult, and it is less dangerous than amputation.

In 1885 I published a case in which reduction was attempted on somewhat similar lines. After renewed efforts by taxis and pressure the abdomen was opened and the constricted ring dilated by bone glove stretchers. A thread of whipcord was then passed from above through the fundus, and a button was attached to the distal end. Continued upward traction for nearly an hour failed to make any impression towards replacement. Two weeks later the condition of the uterus induced me to remove it through the vagina by elastic ligature. The patient made a rapid recovery.

The Hand and Instruments. — Dr. Thomas used as a substitute for the hand a conical plug of box-wood four inches long for making counter pressure over the abdomen. The cone was inserted into the abdominal ring of the uterus, and it was gradually forced down into the inverted fundus for such a distance as to dilate the cervix and allow reposition. A rectal bougie has been used for the same purpose, or a cone eight inches long and one inch diameter, or forceps wrapped with gauze.

Elastic sustained Pressure. — Sustained pressure has been obtained in a variety of ways. Dr. Tyler Smith in 1858 made an important advance upon the former methods of treatment by the use of elastic pressure. He succeeded by placing a Gariel's air pessary into the vagina, upon which external pressure was exercised by a T-bandage and a graduated compress placed at the vulva. By this means slow and gradual dilatation of the os is produced, with softening of the cervical ring; and opportunity is thus given for the inverted uterus to recover itself, or assistance may be given by the hand. Dr. Thomas modified this plan by packing round the inverted uterus with tampons of carbolised cotton soaked in glycerine; then he introduced an india-rubber bag filled with water, and retained it in position by a broad strip of plaster passing between the thighs from the lumbar region behind to the umbilicus in front. Pressure is regulated by injecting more water, or letting some out by means of a stop-cock. As already noted, the same principle has been adopted in a more manageable form by the use of Barnes' bags filled with air. "A bag consisting of a double-walled india-rubber capsule which is slipped over the uterus has been devised by Thiry. When distended with air it presses and pushes up the inverted fundus."

Dr. White of Buffalo was one of the earliest surgeons to direct attention to the benefit of sustained pressure. In his plan pressure is made by a spiral spring, one end of which is placed against the breast of the operator. The spring is prolonged into a curved stem of wood or rubber, at the end

of which is a disc tipped with soft rubber. One hand is introduced into the vagina to grasp the uterus and keep the cup in position, while the free hand is employed over the pubes to make counter pressure, and assist in expanding the inner depression of the inversion. The spring requires a pressure of eight to ten pounds to bring it down. With the patient in the dorsal position at the end of the table, and under an anæsthetic, this method is capable of producing effective results, tedious and wearisome though it be.

Elastic Pressure.—This is by far the most efficient method yet known. The cardinal points are that it should be gentle, elastic, and sustained in

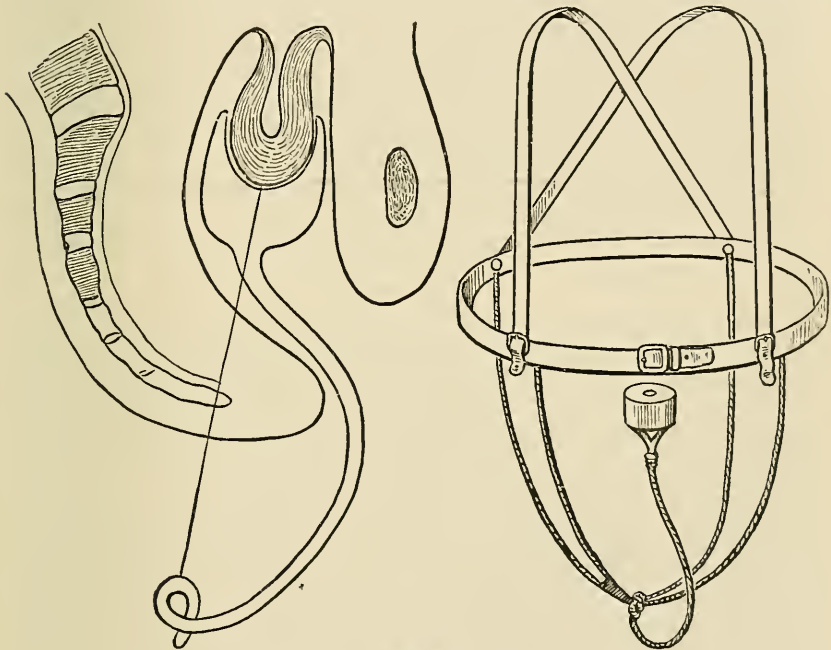

FIG. 242.

the direction of the pelvic axes. It must be repeated again and again, if necessary, and kept up persistently and perseveringly with vigilant care.

With this method in view previous prolonged handling, squeezing, and pressure by taxis, is unwarrantable. It is wiser and safer to begin with it at once after preliminary antiseptic irrigation. Aveling's repositior is the best means of producing the pressure. This consists of a stem with a double curve—perineal and pelvic—surmounted by a cup which is placed against the fundus. The pressure is exerted by four elastic rings fastened by bands to a waist belt, which in its turn is supported by shoulder-straps. By the adaptation of these the degree and the direction of the pressure can be very fairly regulated. Cups of different size are

made to fit the stem. When the inversion is reduced the cup is sometimes retained within the uterus, and is not easily extracted. In one case I had considerable difficulty in getting it out.

In a case happening under Scanzoni's (69) notice the button end of a stem was retained under similar circumstances. The advice he gave might be followed; that as the stem had entered by firm and persistent pressure it should be removed by the same means. An elastic band was attached from the end of the stem to the bedpost, and it was thus gradually withdrawn.

Dr. Galabin obviates this danger by making the cup form the summit of a cylinder  $1\frac{3}{4}$  inches long. Thus the cervix is prevented from closing up after reduction, when the instrument is readily removed. Careful watching is necessary when the instrument is in place; the bands may require tightening at intervals, and, if there be much pain, opiates must be given. Restoration is generally effected by this plan within forty hours. In my own case three days elapsed before the reduction was complete, but it was necessary to suspend it for some hours on account of the pain produced. Aveling states that a pressure of  $2\frac{1}{2}$  pounds is sufficient to effect reduction. He reports eleven cases successfully treated by this method, and goes so far as to say that every case of inversion can be cured by reposition. However, he subsequently recorded one where it did not succeed.

When known methods have failed after repeated attempts, or where firm adhesions exist, the inversion may become irreducible. Under these circumstances Emmet proposes, "where the fundus can be gotten within the cervix," to bring the edges of the cervix together by silver sutures for a time, until additional efforts at reduction can be made. Failing this he denudes the edges of the cervix, and unites them permanently, leaving a small space open at each end.

He regards this plan as far preferable to abdominal incision or to amputation. Indeed, he looks upon the mortality of amputation as so great that he would not resort to the operation under any circumstances.

Amputation. — The mortality of this operation is as high as 30 per cent. It should only be practised as a last resort. Indeed, in the light of present knowledge the instances in which it is admissible must be excessively rare. When in the wide field of treatment the relative infrequency of irreducible cases is remembered, the chances of being urged to amputation must be very remote. The chief dangers of amputation are hæmorrhage, retraction of the stump within the peritoneal cavity, and septicæmia. Amputation by the knife, with certain precautions, is the most direct method. The uterus is drawn down and a temporary elastic ligature placed around the neck; three or four wire sutures are then passed through the cervix from before backwards, and the uterus amputated half an inch below these. Bleeding points are ligatured, and the sutures are brought firmly together over the stump. Superficial sutures are placed to unite the mucous membrane, and the elastic ligature is now removed; or a ligature may be passed through



the neck and tied laterally so as to control the uterine vessels, the uterus being removed below this.

Vaginal hysterectomy is another method of removing the uterus. The broad ligaments are tied or clamped with forceps on both sides, when the uterus can be rapidly removed by scissors. The vaginal space is packed with iodoform gauze. Rigid antiseptic precautions place these operations on a more secure footing, and greatly enhance the prospects of recovery.

The elastic ligature still finds much favour in France. It is described by Courty as presenting more advantages and fewer dangers than any other plan of extirpation. He advises that before applying it a groove should be made round the pedicle of the tumour by the actual cautery. Elastic tubing is used, and it is tightened daily until the tumour falls off, which is generally about the twelfth to the eighteenth day.

The ecraseur has been used with good results in the hands of some surgeons, and the galvano-cautery has been successful in the practice of Spiegelberg. The use of both is destined to aid the progress of art towards more efficient and safer measures based upon sounder principles.

EDWARD MALINS.

#### REFERENCES

1. ABEGG. "Inversio Uteri," *Centralb. f. Gynäk.* Leipz. 1893, xvii. 473.—2. ARBUCKLE. "Complete Cure of Inversion of the Uterus," *Lancet*, London, 1885, ii. 1183.—3. AVELING. "On Inversion of the Uterus, with Ten Cases successfully treated by the Sigmoid Repositor," *B. M. J.* Lond. 1886, i. 475.—4. BALDY. "Inversion of the Uterus," *Med. and Surg. Rep. Phil.* 1891, lxx. 123.—5. BARBER. "Case of Inversion of the Uterus, with complete Prolapse," *Lancet*, Lond. 1887, ii. 600.—6. BARKAS. "Complete Inversion of the Uterus," *Australas. Med. Gaz.* Sydney, 1886-7, vi. 223.—7. BARNES. "Inversion of Uterus," *Lancet*, Lond. 1886, i. 420.—8. BARNES. "Complete Chronic Inversion of the Uterus," *B. Gynæc. J.* Lond. 1888-9, iv. 258.—9. BARRETT. "Complete Inversion of the Uterus," *B. M. G.* Lond. 1887, i. 508.—9a. BARRIER. *Bulletin de l'Acad. de méd.* April, 1852.—10. BATTLEHNER. "Ueber Gebärmutterumstülpung," *Verhandl. d. d. Gesellsch. f. Gynäk.* Leipz. 1888, ii. 319.—11. BIGGS. "Inversion of the Uterus," *B. M. J.* Lond. 1886, i. 739.—12. BOXALL. "Complete Inversion of the Uterus," *Mid. Hosp. Rep.* 1891, Lond. 1892, 70.—13. BREWIS. "Spontaneous Inversion of Uterus," *Edin. M. J.* 1887-8, xxxiii. 128.—14. BROWNE. "A New Operation for the Reduction of Chronic Inversion of the Uterus," *New Y. M. J.* 1893.—15. CHADWICK. "Gradual Reposition of an Inverted Uterus by a New Contrivance," *Boston M. and S. J.* 1885, cxii. 289.—16. CHAMBERS. "A Case of Complete Inversion of the Uterus of 25 Months' Duration, reduced by graduated continued Pressure in less than 4½ Hours," *Australas. M. Gaz.* Sydney, 1885-6, v. 66.—17. CRAMPTON. "Complete Inversion of Uterus following Parturition, with Tables," *Am. J. Obstet.* N. Y. 1885, xviii. 1009.—18. CULLINGWORTH. "Inversion due to large Polypus," *Lancet*, Lond. 1890, i. 1355.—19. DAHLMANN. "Zwei Fälle von Inversion aer Gebärmutter nebst einigen Bemerkungen," *Frauenarzt*, 1887, ii. 119.—20. DANDOIS. "Inversion utérine chronique, ligature élastique, guérison," *Rev. méd. Louvain*, 1885, iv. 533.—21. DAVIES. "Chronic Inversion of the Uterus," *B. M. J.* Lond. 1885, ii. 737.—22. DEMONS. "Un cas d'inversion utérine," *Mém. et Bull. Soc. de méd. et chir. de Bord.* 1886, 59.—23. DODGE. "Case of Inversion of the Non-periperal Uterus," *Am. J. Obst.* N. Y. 1890, xxiii. 381.—24. DUMÉNIL. "Cas de réduction d'une inversion utérine par la ligature élastique," *Union méd. de la Seine-Inf.* 1886, Rouen, 1887, xxv. 31.—25. DUNCAN, J. M. "Clinical Lecture on Chronic Inversion of the Uterus," *Med. Times and Gaz.* London, 1884, i. 275.—26. DUNCAN, W. "Complete Inversion of Uterus of Nine Years' Duration, Reduction by Aveling's repository; cure; remarks."

*Lancet*, Lond. 1884, ii. 590.—27. EMMET. Principles and Practice of Gynæcology, p. 419, 1875.—28. FAUCON. "Sur une forme particulière d'inversion polypeuse de l'utérus (inversion supéro-latérale), amputée par l'écraseur-linéaire, avec suture," *Bull. Acad. royale méd. de Belge*, Brux. 1887, iv. s. 1, 723.—29. FOX. "A unique and very interesting Case of Acute Inversion," *Med. Reg. Phila.* 1887, i. 87.—30. GRAY. "Inversion of the Uterus," *B. M. J.* Lond. 1892, i. 1253.—31. HARVEY. "Amputation of Inverted Uterus," *Indian M. Gaz.*, Calcutta, 1886, xxi. 154.—32. HENSGEN. "Zwei weitere Fälle von Inversion der Gebärmutter," *Frauenarzt*, Berl. 1887, ii. 373.—33. HERMAN. "Inverted Uterus," *Tr. O. S.* 1886, xxvi. 83.—34. HERTOGHE. "Amputation de l'utérus inversé par la ligature élastique; guérison," *Rev. méd. Louvain*, 1888, vii. 499.—35. HICKS. "Case of Inversio Uteri; reduction; recovery." *B. M. J.* Lond. 1889, ii. 1338.—36. HIRSH. "Inversion of Uterus," *Internal Clin. Phila.* 1892, 2 s. ii. 294.—37. HUTCHINSON. "Another case of complete Inversion of the Uterus," *Lancet*, Lond. 1889, i. 886.—38. JOHNSON. "Two cases of Inversion of the Uterus, treated after Wing's method," *Am. J. Obst. N. Y.* 1884, xvii. 815.—39. KARAFIATH. "Uterus-inversion in Folge einer Geschwülst; Operation; Heilung," *Pest. med. Clin. Presse*, Budapest, 1883, xix. 1023.—40. KEMPE. "Case of Inversio Uteri of Four Months' standing; Cure," *B. M. J.* Lond. 1888, ii. 15.—41. KOCKS. "Zur Therapie der chronischen totalen Uterus-inversion," *Centralbl. f. Gynäk.* Leipz. 1890, xiv. 658.—41a. KRONER. *Arch. f. Gyn.* xiv. 1879.—42. KRUKENBERG. "Zur Behandlung der Uterus-inversionen," *Centr. f. Gynäk.* Leipz. 1888, x. 17.—43. KÜSTNER. "Methode Konservirender Behandlung der invertirten Inversio Uteri puerperalis," *Centr. f. Gynäk.* Leipz. 1893, xxii. 945.—44. LAUNSTEIN. "Fall von Inversio Uteri," *Centralbl. f. Gynäk.* Leipz. 1883, vii. 731.—45. LAURENCE. "Complete Inversion caused by a Fibroma in the Fundus; spontaneous Reversion upon Removal of Tumour," *B. M. J.* Lond. 1894, i. 1243.—46. LEE. "Inversion of the non-parturient Uterus and its Treatment, with Notes of two Cases," *Am. of Obst. N. Y.* 1888, xxi. 616.—47. LEFORT. "Inversion utérine; ligature élastique; guérison." *Bull. et mém. Soc. de Chir. de Paris*, 1887, n. s. xiii. 201.—48. LEPRÉVOST. "Inversion utérine irréductible; amputation de l'utérus par la ligature à traction élastique; guérison." *Bull. et mém. Soc. de Chir. de Paris*, 1888, n. s. xiv. 503.—49. MACAN. "Chronic Inversion of the Uterus." *Med. Press and Circ.* London, 1884, n. s. xxxvii. 47.—50. M'INTOSH. "Complete Inversion; Treatment by Abdominal Section," *Med. Rec. N. Y.* 1893, xlv. 176.—51. MALINS. "Chronic Inversion of the Uterus, Abdominal Section; subsequent Amputation," *Lancet*, 1885-7, p. 401.—52. MARCY. "Chronic Inversion; Reduction by a New Method," *J. Am. M. Assoc. Chicago*, 1889, xiii. 86.—53. MARTIN. "Chronic Inversion of Uterus successfully treated with Continuous Elastic Pressure," *Birm. Med. Rev.* 1894, xxxvi. 219.—54. MEYER. "Notes on Two Cases of Inversion of the Uterus," *Austral. M. J.* Melbourne, 1886, viii. 165.—55. MOULLIN. "Inversion of Three Years' Duration, Reduction successfully Accomplished," *B. Gynæc. J.* London, 1891-2, vii. 486.—56. MUNDE. "Laparotomy for Reduction of an Inverted Uterus," *N. Y. M. J.* 1888, xlviii. 451.—57. MURRAY. "Note of a Case of Inversion of the Uterus occurring immediately Post-partum and resulting in spontaneous Amputation," *Tr. Edin. Obst. Soc.* 1882-3, viii. 42.—58. MYERS. "Chronic Inversion with Amputation," *Tr. Am. Ass. Obst. and Gynec.* 1892, Phila. 1893, v. 194.—59. NEWMAN. "Inversion of Uterus, of Sixteen Months' standing, Replacement; Recovery," *B. M. J.* London, 1889, i. 1057; *Tr. Obst. Soc.* 1889, 1890, xxxi. 166.—60. OLIVER. "Uterus inverted for nearly Twenty Years becoming Malignant," *Lancet*, London, 1893, ii. 28.—61. OUTIN. "Renversement de l'utérus; réduction; guérison sans accident," *France méd.* Paris, 1889, ii. 1110.—62. PÉRAIRE. "Inversion utérine complète avec prolapsus consécutive à la délivrance; métrorrhagies abondantes mettant la vie de la malade en danger; réduction de l'utérus; guérison," *Ann. de gynéc. et d'obst.* Paris, 1893, xl. 1894.—63. PÉRIER. "De la ligature à tractions élastiques utérine," *Rev. de chir.* Paris, 1886, vi. 969.—64. PICKEL. "Complete Inversion and Prolapsus of Uterus," *N. Y. J. Gynec. and Obst.* 1891, v. 124.—65. REEVE. "Moot Points in regard to Inversion of the Uterus," *Tr. Am. Gynec. Soc.* 1884. New York, 1885, ix. 69.—66. REID. "Complete Inversion of Uterus reduced by Systematic Tamponment of the Vagina," *N. York M. J.* 1891, No. 263.—67. RÉMY. "Du mécanisme pathogénique de l'inversion utérine récente puerpérale," *Arch. de Toccol. et de Gynec.* Paris, 1894, xxi. 257.—68. RÉMY. "Deux cas d'inversion utérine," *Arch. de Toccol.* Paris, 1891, xviii. 81.—69. SCANZONI. *Diseases of Women*, p. 141.—70. SCHAUTA. "Ein Fall von Inversio Uteri im 78 Lebensjahre," *Arch. f. Gynäk.* Berl. 1892, xliii. 30.—71. SCHOFIELD. "Complete Inversion in a Primipara," *B. M. J.* London, 1891, i. 633.—

72. SCHULEIN. "Beitrag z. Lehre von der Behandlung der Inversio Uteri," *Ztschr. f. Geburtsh. u. Gynäk.* Stuttg. 1884, x. 345.—73. SHAPLEY. "Complete Inversion of the Uterus," *B. M. J.* London, 1887, i. 329.—73a. SIMPSON, Sir JAMES. *Edin. Med. Journ.* July 1867, p. 67.—74. SINCLAIR. "Inversion of Uterus," *B. M. J.* Lond. 1886, i. 641.—75. TAIT. "An Instrument designed to assist in the Reduction of Inversion of the Uterus," *B. Gynæc. J.* Lond. 1888-9, iv. 309.—75a. TATE. *Cincinnati Lancet and Observer*, 1871.—76. TEALE. "Chronic Inversion of Uterus; attempted Reduction by Taxis; Laceration of Vagina into Douglas' Pouch; Recovery," *Lancet.* Lond. 1887, i. 11.—77. TEUFFEL. "Inversio Uteri completa," *Centrabl. f. Gynäk.* Leipz. 1888, xii. 401.—78. WALLACE. "Note on History of Cases of Chronic Inversion of Uterus after Reduction," *Med. Press and Circ.* Lond. 1894, 2 s. lxiii. 108.—79. WATERFIELD. "Acute Inversion of Uterus; spontaneous Reduction; Recovery," Lond. 1893, i. 1109.—79a. WATTS. *Amer. Syst. Gyn.* vol. ii. p. 715. 80. WEISSEBERG. "Inversio Uteri nach Abort; rasche und spontane Reduktion durch Tamponade," *Frauenartz.* Berl. 1889, vi. 8.—81. WERTH. "Ueber partielle Inversion des Uterus durch Geschwülste," *Arch. f. Gynäk.* Berl. 1893, xxii. 65.—82. "Chronic Inversion of Uterus of Twenty-one Months' Duration reduced by Colpeuryesis," *J. Am. M. Ass. Chicago*, 1887, viii. 22; disc. 44.—83. "Spontaneous Reduction of a chronically inverted and completely prolapsed Uterus," *Boston Med. and Surg. Jour.* 1892, cxxvii. 39.—84. "Ein Fall von totaler Inversio Uteri in Folge: spontaner Geburt eines fibrosen Polypen; Heilung," *Memorabilien.* Heilbr. 1894, n. F. iv. 217.—85. "Inversion totale de l'utérus de cause difficile à déterminer," *Gaz. méd. de Nantes*, 1884-5, iii. 117.—86. "Inversion utérine irréductible; amputation de l'utérus par la ligature avec tractions élastiques; guérison," *Lyon méd.* 1886, li. 441, Disc. 455.—87. "Note sur l'inversion utérine et son traitement," *Arch. de méd. et de chir. prat.* Brux. 1887-8, ii. 113.

E. M.

## DISEASES OF THE FEMALE BLADDER AND URETHRA

MORBID conditions of the lower urinary organs in the female, as in the male, chiefly show themselves in pain and frequency in micturition. In a large number of these cases the manifestations depend upon the presence of cystitis in a more or less severe degree; and it is a point of first importance to determine whether cystitis be present, or only some condition resembling it in its more prominent features of pain and frequency of micturition and the presence of pus and blood in the urine: it is important, in the next place, if it be cystitis, to determine on what local or remote cause it depends.

DISEASES OF THE URETHRA. —The morbid conditions met with in the female urethra are but few.

**Developmental defects:** these are, (i.) Entire absence of urethra; (ii.) Hypospadias; (iii.) Deficiency of internal portion; (iv.) Atresia of the urethra (congenital).

**Displacement:** this occurs chiefly as longitudinal traction by displacement upwards of the bladder; it causes frequency of micturition.

**Neoplasms:** such as papilloma and polypi of the mucous membrane; they may cause some obstruction without much local tenderness; in rare



instances sarcoma and carcinoma are met with, but the most common neoplasm is the *vascular growth or urethral caruncle*. The urethral caruncle consists of dilated capillaries in connective tissue covered with squamous epithelium; which form a small bright red tender and vascular tumour at the urethral orifice. The symptoms are pains on micturition or coitus, sometimes retention of urine. The most effective mode of treatment is to destroy the prominence with the actual cautery, care being taken to arrest any bleeding afterwards by plugging and pressure with a perineal band.

**Cysts and Abscesses.**—Cysts containing clear mucoid fluid or pus are occasionally met with in the urethro-vaginal septum; they are due to dilatation and inflammation of Skene's glands which are situated near the mouth of the urethra. Bartholin's glands (corresponding to Cowper's glands in the male) are sometimes the seat of inflammation, suppuration, or neoplasms. Enlarged acinous mucous glands are sometimes found near the external urethral orifice.

**Urethritis** is usually associated with gonorrhœa. The urethra is swollen and tender, and yields pus when pressed upon through the anterior vaginal wall. The most effective treatment is to give diluent drinks and copaiba, to use iodoform bougies locally, and counter irritation, by painting the anterior wall of the vagina with tincture of iodine.

**Dilatation** sometimes occurs as a result of coitus when the vagina is occluded or over-distended. This very rare condition is to be remedied by burning a longitudinal furrow by the actual cautery with the aid of a grooved speculum.

**Tubercular disease** sometimes begins in the female urethra, and when present frequently causes pain or incontinence of urine, hæmaturia or pyuria.

**DISEASES OF THE BLADDER.**—**The congenital defects** of the bladder are malposition, supernumerary bladders, absence, and ectrophy.

The bladder may be protruded in a hernial form when the linea alba is weak or deficient, or when the expansion of the oblique muscles of the abdomen is absent.

If the whole of the front wall of the abdomen is deficient in the hypogastrium, and the bladder properly developed, the bladder will protrude at the opening. This is not the same thing as ectrophy.

In most of the cases of protrusion or displacement of the bladder the condition is not congenital but acquired.

**Displacement.**—Owing to its loose attachment to the wall of the pelvis the bladder in the woman is readily displaced. It is drawn up during labour, and by retroversion of the enlarged uterus, whether this be due to gestation or fibromyoma; or it may be attached to an ovarian or fibroid tumour which has risen into the abdomen. In procidentia uteri, the commonest cause of cystocele, a part of the bladder is displaced downwards, and this may lie outside the vagina. In contraction of the sacro-uterine ligaments the bladder is drawn backwards and held partly open, so that it is never completely emptied.



Great protrusions are sometimes met with in the middle line at the scar of a laparotomy wound, or of an abscess. Over-distension of the abdominal walls from any cause, followed by emaciation or the flaccidity of age, is a sequence which lends itself to hernial protrusion of the bladder as of other viscera. The inguinal, femoral, obturator, and ischiatic foramens have all been the site of cystocele, sometimes accompanied by protrusion of a portion of bowel or omentum. Vaginal cystocele is by no means uncommon in fat and flabby multiparas.

The protruding part of the bladder is uncovered by peritoneum except when accompanied or preceded by an ordinary hernia of large size, or when a great portion of the bladder is included in it.

Besides the weakened condition of the abdominal walls or vagina, or the easy patency of one of the natural openings in the parietes, two other conditions are requisite for cystocele: these are a dilated bladder, frequent and considerable distension, and frequent straining efforts at micturition. As soon as the bladder has escaped at a hernial protrusion it acquires a more or less sacculated or hour-glass form; and the urine, being constantly retained, at length decomposes, and ulceration, calculus formation, or sloughing may follow.

Cystocele has been mistaken for ordinary hernia, and for abscess. It varies in size with the quantity of urine retained, and may be distended by injecting the bladder with warm boracic fluid. In doubtful cases Agnew recommends puncture and an examination of the fluid withdrawn; but this procedure has its dangers.

If a cystocele become strangulated the symptoms may very closely simulate a strangulated hernia; but, in addition, there will almost certainly be other symptoms special to the bladder, such as blood in the urine, painful and frequent micturition, and pain specially referred to the hypogastrium and neck of the bladder.

Petit says that in strangulated hernia of the bladder vomiting is always preceded by hiccough, whereas in hernia of the intestine vomiting precedes hiccough.

*Treatment.*—The pouch of bladder should be kept empty of urine by voluntary micturition or the catheter, and by the application of a truss.

A vaginal cystocele should be treated by an operation for contracting the anterior vaginal wall. Most of the cases which have been recorded as supernumerary bladders have been either sacculated bladders or bladders bisected by a membranous partition. In some the coats have been complete, and others were probably dilated lower extremities of the ureters. In some of the cases in which the bladder was divided into two, there was an opening of communication between them, in others not; one ureter opens into each division. Fantoni and Mollinetti have described cases of true multiple bladders; that of the latter was a woman who had five bladders, five kidneys, and six ureters. Four of the ureters emptied each into a separate bladder; the other two into the largest bladder.

**orifice** is less uncommon in women than in men; it should be treated by applying the actual cautery to the vesical orifice while the wall of the bladder is kept in place by a catheter.

Only a few instances of absence of the bladder are on record. When it occurs the ureters open into the urethra, rectum, or vagina; or on the abdomen, generally in the median line. Agnew quotes a few cases in which individuals so affected lived to adult age, suffering little or no inconvenience; others survived but a few days.

**Ectopion vesicæ** is characterised by a failure in development of the anterior wall of the bladder and of the abdominal wall in front of the bladder; whilst the posterior wall of the bladder projects at the hypogastrium where it is continuous with the anterior abdominal parietes.

This malformation is more frequent in boys than in girls, in the proportion of eight or nine to one.

In its causation the theory of arrest of development is generally accepted. The existence of epispadias, the absence or non-union of the symphysis pubis, and other associated malformations of the genital organs, are arguments in favour of this opinion.

*Morbid Anatomy.*—Ectopion vesicæ appears as a florid red body in the hypogastric, or hypogastric and pubic regions. In very young subjects it is not larger than a nut; in adults it attains the size of an apple.

The surface bleeds readily, and is often painful; the lower part is always moister and more vascular than the upper; and upon it there are two small round projections, which represent the orifices of the ureters: on watching these urine is seen to flow from them—not drop by drop but by a sort of feeble and irregular ejaculation.

At the margin the epidermis is continued insensibly into the epithelium of the mucous membrane, and little islands of it are situated on the mucous surface—in fact, there is a tendency for the epithelium to change into epidermis.

Around the ectopion the cutaneous surface is marked by irregular cicatrices which are considered to be relics of the allantois. Above the ectopion is a median depression—due to the want of the linea alba—as high as the umbilicus. The umbilicus may indeed blend with the ectopion; if not, it is generally very close to it. The umbilical vein is consequently elongated; the urachus and umbilical arteries are proportionately shortened.

In the female there is a separation of the labia majora, of the two sides of the clitoris, and of the labia minora. The external orifice of the vagina is a mere antero-posterior slit; and in some cases the sex of the infant is doubtful. The vagina and uterus are sometimes bifid. The anus is often placed farther forward than normal. One of the most important features is detected by pressing upon the pubic region, when a wide separation of the pubic bones, varying from  $1\frac{1}{2}$  to six inches (3 to 12 centimetres), will be recognised. It is quite exceptional for the pubes to be united at the symphysis.

By rectal examination much is learnt; namely, the very forward pro-

jection of the sacrum, whereby the antero-posterior diameter of the pelvis is diminished. With the finger in the rectum, and the other hand on the hypogastrum, one feels the posterior surface of the ectopic bladder, and the separation of the pubes is still more distinctly perceived.

Dissection shows the perineal muscles to be ill-developed, and the sphincter vesicæ to be absent—at least, in one instance only does it seem that a sphincter of the urethro-vesical orifice has been found. In place of the symphysis is a fibrous band of varying thickness and resistance.

Nothing but a layer of cellular tissue, and not always so much as this, separates the vesical mucous membrane from the peritoneal coat.

The condition of the ureters is very important. Following them from the bladder wall, they dip down into the pelvis before turning up towards the kidneys. They are frequently elongated and dilated.

*Symptoms.*—Individuals with ectopion vesicæ may be otherwise well formed and robust: most frequently, however, they are thin, weakly, and constantly suffering; as the slightest friction from their linen inflames the vesical mucous membrane. Thus they often die from ascending inflammation ending in suppurative pyelophlebitis.

As a result of the constant trickling of urine they are always wet and in discomfort, and frequently affected with erythema, excoriations, erysipelas, or more deeply seated inflammation of the skin and tissues around. Thus they are always in danger of mischief ascending to the kidneys. Sexual appetite, as a rule, does not exist. In the female conception has occurred, the offspring being naturally formed; but delivery is often difficult, and confinement almost always followed by prolapse of the uterus. Many malformations of the vagina coexist, especially in connection with the anus. Double inguinal hernia is very common. Sometimes the ileum terminates in the bladder. Prolapse of the rectum or uterus, club foot, harelip, anencephalus, and spina bifida have also been recorded. Ectopion vesicæ is, happily, very rare. Nendorfer computes its occurrence as twice in 100,000 infants: nine-tenths of the cases of ectopion vesicæ die within a few days of birth. Ectopion is not, however, incompatible with long life, as instances are recorded of individuals so affected attaining the age of 40, 50, and even 70 years.

*Treatment.*—It must suffice here to name the modes of operation performed:—

(i.) To establish a fistulous communication between the ureters and rectum; or (ii.) Between the bladder and the rectum. The mortality of these two methods has been 40 per cent. (iii.) The autoplasmic or flaps method. Mortality, 14·6 per cent. This method has in several cases cured the coexisting inguinal hernias. (iv.) The removal by dissection, or the destruction by escharotics of the mucous membrane of the bladder, except around the orifices of the ureters. Sonneburg, after dissecting off the bladder mucous membrane, sutures the mucous membrane to the base of the epispadias. (v.) To close the bladder by suturing its two margins.

This method is sometimes combined with closure of the interval at the symphysis pubis, after the manner of Trendelenburg.

According to Tuffier the alternatives are as follows: When the case is one of epispadias, with a small fissure at the symphyseal area of the bladder, close the urethra and neck of the bladder by uniting the edges of these parts. So, too, if the defect of the bladder extends somewhat higher, the edges of the bladder should be freshened after dissecting up the mucous membrane without damage to the ureters. If the ectopion is complete and the separation of pubes considerable, divert the urine into the rectum. In a young and vigorous person employ Dubois and Dupuytren's method, which consists in suturing together the margins of the bladder. If the genital organs be atrophied, or the patient weakly, or affected by other malformations, suture the mucous membrane to the root of the urethra; or establish a recto-vesical fistula and destroy the mucous membrane of the bladder.

As regards the autoplasmic methods, the simple flap is inferior to the methods by several flaps; and the method whereby the flaps are superposed is better than that by which they are simply joined together.

**FUNCTIONAL DISTURBANCES OF THE BLADDER. — I. Functional Disease due to Structural Disease of the Nervous System. — (a) *Tabes dorsalis.*** — (i.) On the motor side there may be paralysis without retention. This paralysis shows itself in a delay, varying from a minute to a quarter of an hour, in starting to micturate; the flow may then stop, to go on again after an interval, and within an instant or two after the act seems to be completed, urine may be passed into the clothes. (ii.) Paralysis culminating in complete or partial retention. (iii.) Intermittent incontinence, which may be due to overflow of urine from the bladder; or be caused by a peculiar irritability of the bladder, which leads to a slight discharge of urine directly the patient makes a move to micturate. (iv.) An urgent necessity to pass water, due to tenesmus, accompanied perhaps by cystalgia.

On the sensory side are, in the "excess" direction, urethralgia, cystalgia, vesical colic; in the "insufficiency" direction, anæsthesia of the urethro-vesical mucous membrane, and the loss of muscular sense of these organs. The vesical colic, analogous to the gastric colic, and preceded by crises of variable duration and intensity, is attended by excessive pain. The anæsthesia of the urethro-vesical mucous membrane and of the muscular sense is manifested by the want of consciousness of the passage of urine or of the distension of the bladder. Such patients urinate in a routine manner at stated intervals, not because they have a sense of necessity or any desire to empty the bladder: they must watch in order to know whether they are passing water or not, and when they have finished; some of these patients cannot micturate in the dark.

(b) *Pott's disease, and injuries to the brain and spinal cord*, by interfering with the vesico-urethral nerve centres, cause paralysis with retention, and the incontinence of retention or overflow. Disturbances from such



causes are very familiar. So, too, are the similar disturbances from serious injuries to the brain.

(c) In *general paralysis*, according to Geffrier, there is retention from urethral spasm during the stage of excitement, and retention from paralysis during the period of depression.

(d) In certain cases of *insanity* the retention is voluntary, the patients refusing to pass water just as they refuse to take food.

(e) In *patchy sclerosis* retention due to spasms of the urethra is caused by the irritation of the lumbar centre for the sphincter of the bladder.

2. **Functional Disturbances of the Bladder connected with Epilepsy.** — The principal of these is incontinence. It differs from common nocturnal incontinence in its occasional occurrence, and by the patient awaking with a feeling of extreme weakness, exhaustion, and weight in the head, and with the tongue sore or bleeding. Incontinence sometimes occurs during a fit of hysteria.

In *hysteria* there is occasionally anæsthesia, with spasm of the neck of the bladder; there is great difficulty in beginning to micturate, and this may increase to complete retention. In some hysterical subjects there is involuntary discharge of urine under strong emotion, due to spasm of the detrusor fibres of the bladder. Hysterical retention, due to paralysis of the bladder, is frequent; it is sometimes accompanied by hysterical hemiplegia, or more often by paraplegia. If the paralysis affect both the detrusor and the sphincter vesicæ, these patients get the incontinence of retention.

3. Functional troubles connected with **congenital malformations**, and, 4, those due to neighbouring organs, make what is often described as the **irritable bladder**.

The sensory symptoms are cystalgic pains; the motor symptoms, frequent spasms of the bladder and urethra, which cause frequent, but slow and painful micturition, urgent calls to pass water, and sometimes actual retention.

The causes of the symptoms are congenital atresia urethræ, fissure of the anus, hæmorrhoids, operations on the anus, intestinal worms; or uterine, ovarian, vaginal and vulvar disorders; or operations on these parts.

5. **Functional Vesical Troubles due to Lesions of the Bladder.** — The reflex irritation caused by vesical calculus, tumour, or fissure of the urethra in women produces vesical tenesmus analogous to rectal tenesmus from anal fissure. A deep-seated but slight urethritis near the neck of the bladder often causes cystalgia. These causes of painful and irritable bladder must be recognised in order to treat them successfully.

6. **Functional Vesical Troubles caused by the Condition of the Urine.** — The excess of limpid urine in hysterical women, urates in the gouty, and of phosphates in neurotic persons, and any urine which is extremely acid, are well-known causes of irritable bladder.

7. **Idiopathic functional disturbances of the bladder**, such as cystalgia, and spasms both of the vesical muscle and the compressor

urethræ, sometimes seem to occur independently of any ascertainable cause. True idiopathic cystalgia, Tuffier writes, occurs in persons whose parents are the subject of nervous or rheumatic migraine and who are themselves neurotic. The determining causes are cold, damp, changes of season, constipation, voluntary retention, and irritability of the genital organs.

**8. Functional Vesical Troubles of Mental Origin.**—The enormous influence of the mind over the functions of the bladder are proverbial. That polyuria, as well as frequency of micturition, is due to mental influence is proved by the fact that if the mind is engaged and interested both cease as they do during sleep. The patients may pass water fifty times a day, yet sleep all through the night. A greatly increased capacity of bladder is proved to exist in these cases by the capacity for injections of warm water; and yet a catheter left in the bladder as a drain-tube does not remove the desire these patients have to pass water.

Another form of functional disturbance from mental causes is urethral spasm, manifested either during micturition or during the introduction of an instrument. If it occur during micturition we have the condition so happily described by Sir James Paget as “stammering of the bladder,” which renders the person incapable of micturating in presence of others, or even in a place where the flow of their urine can be heard.

Even when there is no ascertainable lesion about the urinary organs to explain this troublesome condition, there are still many other causes of incontinence both in children and adults for which search must be made.

**Incontinence of urine** assumes two very distinct and different forms—(i.) the incontinence of the drop-by-drop kind, the incessant, continuous dribbling; and (ii.) incontinence in the form of intermittent large evacuations of urine.

(a) The “continual” incontinence consisting in incessant dribbling of urine is due to paralysis of the vesical and urethral (the membranous urethra) sphincters. It may or may not be associated with retention. If it is, the incontinence is merely the overflow of the bladder and is the “incontinence of retention.” If it is “incontinence without retention,” the bladder is no longer serving as a reservoir, but has become merely a part of a conduit placed between ureters and urethra. This is a state of absolute incontinence. “Continual” incontinence, if it has not been caused by over-distension and its effects on bladder and sphincter, is probably always hysterical.

(b) Some children have nocturnal incontinence whose urinary functions during the day are quite normal in every respect. These are the subjects of incontinence of a psychopathic (mental) origin, and they constitute the majority of cases. It is intermittent incontinence of large quantities of urine: it arises from the child having a besetting dream of passing water, and it is aggravated by the fear that she will wet her bed. This form of incontinence always ceases at puberty if not before, when a different turn is given to the thoughts and dreams of these incontinent.

(c) In another class of cases there is incontinence of the intermittent form occurring at night only; but during the day these children have frequent and pressing calls to pass urine, and must give immediate relief to their bladders, otherwise they wet their clothes. This form is due to irritation either of the spinal cord, of the intestines, or of the genito-urinary apparatus. Contracted meatus, oxaluria and lithæmia, and intestinal worms play an important part in it.

(d) In another class of cases the children have both diurnal and nocturnal incontinence. They never think for an instant of trying to prevent it. They pass water in the daytime with the same unconsciousness as prevails at night. This form is due either to defective contractile power in the urethral sphincter, or to urethral insensibility. In adults this may occur in consequence of hysteria, of overstretching of the sphincter by too large an instrument, or by digital examination. It also occurs as a consequence of spinal lesions, especially *tabes dorsalis*.

(e) During epileptic seizures incontinence takes place at the end of the attack, whether it occur by night or day. It is succeeded by a feeling of extreme prostration and evidence of the tongue or cheek having been bitten.

All forms, except the epileptic, have a tendency to disappear at puberty. After twenty-five years of age they are quite exceptional, if not altogether unknown. Spontaneous cure sometimes unexpectedly follows an attack of fever or some other illness. In some cases, after the incontinence ceases, these persons are obliged to pass water once or twice during the night; and this necessity may continue even throughout life. Many of them, however, get cured of their incontinence, only to become the prey of some other nervous affection such as spasm of the bladder, or irritable bladder, or to become confirmed hypochondriacs.

*Treatment.* — In the psychopathic form moral treatment is the only useful one. The little patient must not be scolded, or punished, or reproached, or made a laughing-stock. She should be encouraged, reassured, and even told not to mind the accident. Let her not go to sleep with a final instruction that she must not wet herself, whereby her last thought is made a connecting-link with her habitual dream. On the contrary, coax her, if possible, into the hope that she is cured; and assure her she ought not to be troubled if she should find she is not. Much is gained if a few nights pass without an accident, and this is sometimes obtained by waking the child just before the hour at which the nurse has ascertained that micturition takes place. Means are sometimes recommended to lighten sleep and increase the irritability of the neck of the bladder. A hard bed, a little tea or coffee taken late before going to bed, are calculated to obtain the one aim, and the passage of catheters or sounds will sometimes accomplish the other. [For treatment by electricity, *vide System of Med.* vol. i. p. 372.]

For incontinence due to irritable bladder the treatment consists in the removal of the cause; thus vermifuge remedies and improvement in dietary to correct oxyluria or lithiasis, are among the means which will be employed.

Incontinence from atony, or from paralysis, will be often rapidly cured by electrolysis applied to the hypogastrium, or even within the cavity of the bladder.

**CYSTITIS.** — I. **Acute cystitis** in the female, though less frequent than in the male, is nevertheless far from rare. The absence of the prostate and of the retaining influence of the male urethra, are largely accountable for this. Other causes, such as gonorrhœa, tuberculosis, calculus, and neoplasms, are common to both sexes; while the proximity of the uterus and the tendency of the bladder to sympathise with its diseases and displacements add a new set of causes in the female.

The physiological solidarity which subsists between the two organs is due not only to the close relationship, but to the remarkably free vascular communications which exist between them. In certain cases, therefore, the bladder is subject not only to compression but to hyperæmia by extension due to this vascular connection. In addition to the fact that the main vesical and the main uterine arteries arise from the hypogastric trunk there is a free, direct distribution of smaller arterioles from the anterior aspect of the uterus, and the vesical and anterior uterine veins actually unite. Observation shows that there is some increased frequency of micturition, associated in some cases with a slight amount of dysuria, just before and after the occurrence of the catamenia: this is more marked in multiparas and in cases of subinvolution of the uterus.

It is found also that cases of chronic cystitis commonly exhibit exacerbations at these periods (West, Laugier, Bernardet); and a similar increase is noticed with suppression of menses or at the menopause (Civiale).

During gestation there is an increased vascularity of the neighbouring parts, which is readily observed in the vagina and vulva, and depends on increase in the size and number of the veins and arteries, as well as on dilatation of capillaries; thus is produced the so-called vaginal pulse, appreciable by the finger (Oisander), which extends also to the bladder. Frequent micturition in the early months of pregnancy, before there has been any notable enlargement of the uterus, is so habitual that it is scarcely complained of. More than 50 per cent of women experience this increase in frequency, pain and slight hæmorrhage, but they are most marked in primiparas.

Cystitis associated with chronic inflammatory conditions of the uterus is most rebellious to treatment, and often disappears only with subsidence of the uterine disease; in cases of urinary trouble, of which the pathology seems obscure, the uterus should always be carefully examined. The mechanical influence of pressure by the uterus or its contents leads both to diminished capacity and to congestion, which result in greater irritability of the bladder and need for emptying it. This is most marked when there is forcible and continuous pressure from the head of the fœtus or dystocia, particularly if the pelvis be narrow; in prolonged labour this pressure, though short of producing contusion and sloughing, may lead to cystitis.



Compression differently applied so as to lead to retention of urine is a fruitful source of cystitis. Tumours, displacements of the uterus, or even inflammatory exudations, causing compression between them and the symphysis pubis, interfere with the escape of the urine, produce both congestion and distension of the bladder, and may lead to incontinence, rupture, or grave inflammation. Such cases require gradual evacuation of the bladder and removal of the pressure. It is here, for the most part, that a peculiarly intense form of cystitis occurs characterised by expulsion of membrane in the form of a sac moulded to the internal surface of the bladder.

Cystitis in woman, then, is met with, particularly at the menstrual periods; at the menopause; in connection with a congested state of the uterus from pathological causes; in early pregnancy, influenced by the extension of hyperæmia or by retroversion and consequent retention of urine; and towards the end of gestation owing to malformation or malposition of the fœtus. Postpuerperal cystitis, which is generally the most severe, may be due to direct toxic infection, to fissure of the neck of the bladder, or even to the use of a septic catheter. Apart from pregnancy cystitis may be set up by cold, excessive coitus, or voluntary over-distension of the bladder.

*Etiology.*—The causes of acute cystitis are (a) remote and (b) immediate. The *remote* are either general or local.

Certain constitutional conditions favour the occurrence of the disease: these are commonly stated to be rheumatism, gout, and tubercle.

Cold, improper food, and defective hygiene are also regarded among the causes of a remoter kind.

The composition of the urine sometimes disposes to cystitis; it is in this manner, no doubt, that gout is a cause of it. The toxic state of the urine in fever patients, as well as the retention of urine which often affects them, induces congestion of the bladder. Cantharides, and some other drugs which are eliminated by the kidneys, by passing over the mucous membrane of the bladder, have a distinct power to cause frequency and pain in micturition.

*Immediate Causes.*—These are catheterism, gonorrhœa, vaginitis, and other infective processes about the vulva and external urethral orifice. They all produce cystitis by provoking a direct microbial infection of the vesical mucous membrane by means of the secretion and discharges conveyed to the bladder from the urethra.

*Pathology.*—The first changes in cystitis are a pronounced injection of the blood-vessels of the mucous membrane, especially about the ureteral orifices and the neck of the bladder. As the inflammation advances the mucous membrane swells, takes a bright crimson colour, and the distinct outline of the distended arborescent vessels disappears. Microscopically, the epithelial cells are swollen, their nuclei are broken up, and the rete mucosum is infiltrated with leucocytes and embryonic cells. The muscular coat is sometimes similarly infiltrated. Abscesses, ulcers, and gangrene may result.

The bacteriological study of cystitis goes to show that several forms of pyogenetic bacteria are capable of exciting cystitis; but the microbe which has been most generally met with is the bacterium coli commune. Others are the uro-bacillus liquefaciens and the ordinary agents of sup-puration; and, very much more rarely, the bacillus griseus, the micro-coccus albicans amplius, and the diplococcus favus. In men and women it is the colon bacillus which is most frequently found, and which is, indeed, in men the agent of almost all cases of cystitis; but in women the staphylococci, as the elements exciting puerperal and post-partum cystitis, are met with almost as frequently as the colon bacillus. In cystitis from gonorrhœa, as well as from other causes, the same bacteria are found; it is quite exceptional to meet with gonococci.

*Symptoms.*—These are frequent micturition—the desire being so imperative that the action of the bladder cannot be controlled, though but a small quantity of urine may be present; considerable smarting followed by some pain after the bladder is emptied; and the presence of pus and sometimes of blood in the urine, often only at the end of micturition. Acute cystitis appears in two very different degrees; one almost insufferable to the patient and alarming to witness, the other much less severe and dangerous.

The severity and duration of the symptoms are very variable. Attacks occurring during pregnancy are usually very benign, while those following delivery are even more severe and prolonged than cystitis occurring in man. Apart from pregnancy inflammation of the bladder undergoes exacerbation at the catamenial periods.

Besides the above functional symptoms there are certain *physical signs* due to the condition of the bladder. These are: (1) pain and tenderness over the trigone felt on digital examination through the vagina; this pain is much accentuated if at the same time pressure be made over the hypogastrium. (2) Intravesical tenderness. Usually in passing a catheter the discomfort experienced by the pressure of the beak of the instrument along the urethra ceases at once after its entrance into the bladder; but when cystitis exists, pain is aggravated by the presence of the instrument within the neck of the bladder. (3) Distension of the bladder with an antiseptic solution. If this is attempted, intense pain, accompanied with uncontrollable desire to empty the bladder, follows the injection of a very small quantity.

As regards the question of temperature, M. Guyon has pointed out that there is no fever in acute cystitis, that the most painful forms of the disease show no elevation of temperature whatever, and that as soon as a febrile temperature appears in a patient with cystitis, it is certain that there is some perivesical, or, much more commonly, some uretero-renal inflammation.

*The method of examination* in these cases is direct exploration by the finger in the vagina or by the hand on the hypogastrium—or by the two combined. In this way the site and degree of tenderness may be ascertained. In certain acute cases the introduction of the finger into

the vagina, or the mere pressure of the hand on the hypogastrium, provokes extreme suffering. In less severe instances the thickness of the inflamed walls may be gauged by the combined method; or this may be arrived at by pressure of the finger forwards against the pubes. The introduction of the sound into the bladder also may demonstrate the exact points and degree of tenderness.

*Diagnosis.*—The affection as a rule is easily diagnosed by the three classical symptoms: frequency of micturition; painful micturition; and pyuria. The presence of all three of them is necessary. No one of them, taken alone, can establish a right diagnosis.

It is not by the amount or character of the sediment, but by the pain and tenderness on pressure per vaginam, and the fact that the first and last portions of the urine contain most pus, that we diagnose the cystitis to be of the neck and trigone of the bladder. When the whole of the bladder surface is alike involved the pus is uniformly diffused through all the urine.

The cause of the cystitis ought always to be ascertained, and this can easily be done in the case of calculus or new growth. The chief difficulty consists in distinguishing tubercular cystitis in its early stage from cystitis due to a chronic urethral discharge. The family history of the patient, the bacteriological tests by means of the microscope or bacilli culture, and the presence of tubercular deposit in other parts, will give the clue to the cause.

Pericystitis will be diagnosed by the high temperature, by the tumefaction felt through vagina or above the symphysis pubis, which is not removed by using the catheter, and by the signs of deep-seated suppuration. It is very rare.

A frequent desire to micturate, apart from any fever or alteration in the character of the urine, may be met with in cystocele; but this condition is readily recognised, on examination, by a bulging into the vagina, and by the ability to recognise the sound when introduced in the pouch.

The presence of pus in the urine, which is one of the prominent features of cystitis, may be met with on account of vaginal discharges; but the other symptoms are absent, and on closer examination the source of the discharge should be discovered.

The differential diagnosis of the various forms of cystitis is a very much more tedious and difficult affair. A matter of the first importance is a methodical examination of the uterus and its appendages; so frequently does the bladder participate in vascular disturbances of this organ. It is also necessary to search for any evidence of gonorrhœa either in the patient or, if she be married, in her husband. The recognition of pregnancy again, in association with comparatively mild manifestations, is a sufficient indication of the probable cause of the malady. A bacteriological investigation of the purulent deposit in the urine should be undertaken in prolonged or severe cases with a view of discovering the gonococcus or the tubercle bacillus; but the most important means

of ascertaining any local condition consists in the bimanual examination of the bladder, and in the introduction of the finger into the bladder through the dilated urethra. This is undoubtedly the best means of discovering any foreign body, new growth, or morbid condition of the bladder wall.

*Treatment.* — The cause of the cystitis must be removed as soon as possible, and the treatment, in appropriate cases, should be directed towards the uterus where this is also affected. Cases associated with pregnancy are not usually severe, and the termination of gestation may be counted upon to end the cystitis. Baths, narcotics, and balsamic drugs are beneficial; but in really severe cases there is no remedy to be compared with injections of a few drops of silver nitrate (1–500), repeated at such intervals as give the pain of its introduction time to subside.

The most severe cases can only be relieved by dilatation (digital) of the urethra, or even by a vesico-vaginal section (kolpocystotomy) which gives the bladder complete physiological rest.

**II. Chronic Cystitis.** — As a rule cystitis in woman is of the chronic form; though some of the most acute cases I have witnessed have occurred in women after parturition.

The cystitis attributed to rheumatism and gout, as well as tubercular cystitis, is of a slow and persistent kind.

*Morbid Anatomy.* — The mucous membrane of the bladder is of a slate colour, ecchymosed in places, marbled purplish, blackish, or greenish, and covered with an adherent layer of mucus. Sometimes there are large or small ulcers on the surface. The changes in the mucous membrane affect the bladder throughout, but are most marked about the trigone, and least so about the base of the bladder. The mucous membrane is softened, thickened and swollen, and sometimes small abscesses are present both in the membrane and beneath it. The epithelium is exfoliated, the basement membrane infiltrated, and the capillaries hypertrophied. The muscular coats are thickened. The different conditions presented by the mucous membrane have given rise to names as various. Thus are described ulcerative cystitis, gangrenous cystitis, “croupous cystitis” (that is, cystitis attended with the production of false membranes), and the villous form of cystitis (cystite fungo-vasculaire). To name these varieties is to indicate the different aspects the mucous membrane may present.

In the croupous cystitis the false membrane is of a yellowish colour; it is composed of fibrinous material, containing in its substance leucocytes and epithelial cells, and it is sometimes encrusted with phosphates. This membrane, which is frequently formed in very acute cystitis and in the cystitis of lying-in women, may invade the ureters and the renal pelves.

In other cases the false membrane is made up entirely of epithelium from fifty to one hundred times as thick as the normal vesical epithelium.

In gangrenous cystitis the false membrane may be mixed with some of the constituent parts of the bladder membrane more or less destroyed.



*Symptoms.*—Chronic cystitis may arise insidiously, or may be the sequel of acute cystitis.

The symptoms are the same as those of acute cystitis, but in a very much milder degree. The three cardinal symptoms—frequency of micturition, painful micturition and pyuria—are present together. The degree of pyuria is extremely variable. The pus is always most abundant at the commencement and finish of micturition, which indicates that its chief source is the mucous membrane about the neck of the bladder. It differs much in appearance also in different cases, being sometimes yellowish or greenish; sometimes tenacious, glairy, stringy, and adherent to the bottom of the vessel, like a gelatinous coating of greater or less thickness, which cleaves for some seconds to the vessel on pouring off the urine, and then leaves it like a solid or semi-solid mass.

The urine of chronic cystitis is alkaline and, if not actually ammoniacal, has a strong offensive odour. When the mucous membrane is sloughing the urine has an odour characteristically offensive.

The physical symptoms of chronic cystitis are very slight; and the general good health is maintained by many patients for a long time, even when the quantity of muco-pus is very large. After a time, however, they become feeble, lose flesh, and look pale and sallow; the skin dries, the tongue is furred, and the digestion becomes difficult or painful. In a large number of cases chronic pyelo-nephritis is gradually induced; in others, an acute attack of suppuration throughout the higher urinary mucous track proves fatal.

*Diagnosis.*—Before making a diagnosis we should inquire as to the three coexisting cardinal symptoms; namely, the frequency and the pain of micturition, and the presence of pus or muco-pus in the urine. The conditions with which chronic cystitis is most likely to be confused are neuropathic states of the bladder, tuberculosis of the bladder, and pyelo-nephritis.

In neuropathic conditions pus is generally absent, though pain and frequency of micturition may be present. The bladder is not oversensitive to the catheter, nor to vesical injections. With even the smallest trace of pus we ought to exclude simple neuralgia.

In pyelo-nephritis there is a uniform turbidity of the urine, and the turbidity remains even after the urine has had time to deposit; the general health is impaired, there are feverish attacks and, if the bladder is unaffected, the urine is acid. If the bladder be carefully washed out, the urine which flows away through the catheter immediately after is turbid with pus.

*Treatment.*—The proper treatment of chronic cystitis consists in the daily irrigation of the bladder by suitable antiseptic solutions. This irrigation must be conducted on a careful and systematic plan; not only as regards the details of antiseptic precautions, but in other respects as well. It is harmful to throw in too much fluid at a time, or to inject it with too much force. A tender, inflamed bladder is irritated, not soothed, by such treatment. A soft, flexible catheter of No. 8 or 9 size should

always be used if possible; and the solution to be injected should be of the temperature of the body, and not too strongly impregnated with the antiseptic substance. Only two, three, or four ounces should be injected at a time; and then, after being retained for a few seconds in the bladder by keeping the finger tip on the end of the catheter, it should be allowed to escape. This process should be repeated till the solution returns as clear, or nearly so, as when it was injected.

The best means of injecting the solution is by a 4 or 6-ounce india-rubber bottle, fitted with a graduated nozzle and stop-cock such as are made for this purpose. Or, instead of the india-rubber bottle, a glass irrigator, with a long tube and nozzle at the end, can be hung above the patient's head. This is, perhaps, a more convenient plan when the washing out is done by the patient herself.

Various solutions are employed, thus, acetate of lead (1 or 2 grains to 4 ounces of water); dilute nitric acid (2 or 3 minims to the ounce); dilute phosphoric acid (3 or 4 minims to the ounce); acetic acid (4 minims to the ounce). These are especially useful where there is a great tendency to phosphatic encrustation of the bladder. Sir Henry Thompson recommends biborate of soda and glycerine; his formula is 2 ounces of glycerine, 1 ounce of biborate of soda, and 2 ounces of water; of this mixture,  $\frac{1}{2}$  an ounce is added to 4 ounces of water to form the injection.

Mr. Nunn, as long ago as 1872, used and recommended a solution of quinine sulphate, in the proportion of 2 grains to 3 ounces of water increased to 1 or 2 grains to the ounce. Another drug recommended by Sir Henry Thompson is nitrate of silver of the strength of  $\frac{1}{2}$  to 1 grain in 4 ounces, increased to  $\frac{3}{4}$  grain to the ounce. Salicylic acid ( $\frac{1}{15}$  per cent) is recommended by Bryan of St. Louis for cleansing the bladder of tenacious muco-pus. Creolin in  $\frac{1}{2}$  per cent solution, resorcin,  $\frac{2}{15}$  per cent, and a weak solution of boroglyceride are among the numerous substances which may be tried. Instillations, in the form of 20–30 drops of 1 in 50 solution of nitrate of silver, or of sublimate solution (1 in 10,000 increasing to 1 to 5000), are considered by many French surgeons to be the best means of disinfecting the bladder. Much benefit, however, is often derived from an injection of a drachm of iodoform emulsion of the strength of two scruples of iodoform to an ounce of water.

The diet must be carefully regulated; alcohol is to be forbidden.

In women dilatation of the urethra, vesico-vaginal cystotomy, or hypogastric cystotomy, may have to be performed for drainage. Except in cases where it is reasonable to expect that the drainage will not long be required, the latter operation is to be preferred. In many cases of cystitis sanmetto in drachm doses three times a day does excellent service. So also does the solution of parsley and kola seed mixed with coca and saw palmetto made by Bell and Company of Oxford Street, and named by them "liquor petroselini cum serenoa compositus." Tyson recommends santal oil to be administered before meals, and an injection of sodium salicylate (a drachm to a pint) or of alum solution to be used.

**III. Tuberculous Disease of the Bladder.**—This is a disease which

affects the period of activity of the sexual organs, but is met with occasionally in children under four years of age, and also in extreme old age. It is three times more common in men than in women.

The general causes are the same as of tuberculosis elsewhere. The local are to be found in the frequency of gonorrhœa and other suppurative discharges, and of infective cystitis which, in persons with this proclivity, are apt to pass into tuberculous disease.

*Morbid Anatomy.*—The bladder is generally small, shrunken, thickened, and surrounded by a bed of sclerosed fibro-fatty tissues which diminishes the risk of perforation. The mucous membrane is red, irregular, and fungous-looking, especially about the trigone and about the orifices of the ureters. Minute gray miliary tubercles are occasionally seen; they may be more or less confluent, but do not form the larger cheesy masses so often met with in the kidneys, prostate, testes, and vesiculæ. Ulceration is present in the more advanced stages: the ulcers have the characters of tuberculous ulcers of other parts; they may be small and numerous, or a large ulcer may have arisen by the coalescence of smaller ones; their depth varies from mere surface destruction to actual perforation. Though perforation is rare, it sometimes results in fistulous openings into the rectum, vagina, or perineum; or, after forming an abscess in the cavity of Retzius, an opening may be established through the hypogastrium. Ulceration may extend through the urethrovessical orifice and invade the urethra. I have met with deep ashy gray tuberculous ulcers in the urethra of girls, and also tuberculous abscess at the vesical end of the ureter.

It is very rare for the bladder to be the only part of the genito-urinary apparatus affected at the time of death.

In cases of pulmonary phthisis the bladder is sometimes found in a very early stage of tuberculosis without the appearance of any signs of its existence during life.

*Symptoms.*—The first symptom is frequency of micturition after meals and at night. Then the urine is slightly tinted with blood more or less, and at longer or shorter intervals. Later still, pain occurs and the urine is much thicker and contains pus; then it is that cystitis appears, and, as Tuffier writes, the disease, which till then was “vesical tuberculosis,” becomes “tuberculous cystitis.” So it may last for years without very greatly affecting the general health.

The functional symptoms are (i.) frequency of micturition; (ii.) hæmaturia; (iii.) pain; (iv.) certain morbid constituents of the urine. Each of these symptoms must receive a brief notice. The frequency of micturition comes on insidiously, and may exist for a long time without attracting much attention. It is due to a slight congestion of the mucous membrane, and increases with its cause, till at length the need to pass water becomes very imperious, and occurs every hour, or even every half-hour; and, in the gravest cases, it may be almost continuous and tantamount to a condition of “false incontinence.” It is generally worse at night than in the daytime.

Hæmaturia is an early symptom but, like the frequency, it may be so slight as to escape the patient's observation for a time. It is compared to the hæmoptysis of pulmonary tuberculosis and, like the frequency of micturition, is due at first to active congestion of the mucous membrane; later, however, there may be an actual hæmorrhage from the ulcerated surface. As an early symptom it is spontaneous and slight, the urine being faintly pink or rose-tinted throughout; but a few drops of pure blood may issue at the end of micturition. As it comes, so it goes, without obvious cause; it is thus unlike the hæmaturia of calculus, but like the hæmaturia of tumour. In one respect, however, it differs; the bleeding of tumours is free and abundant, the hæmaturia of tuberculosis is slight. In the middle stages of the disease the hæmaturia may cease; but in the later, if it should recur, it may be very considerable.

Pain is an indication of cystitis. It is often brought on by sounding, after which the three cardinal symptoms of cystitis may appear; namely, frequency of micturition, pain, and pus. In some cases the pain of tubercular cystitis is by no means severe, and certainly not incompatible with the ordinary pursuits of life. In others it is frequent and intense, or even continuous and agonising; it precedes, accompanies, and follows micturition; and as the frequency of micturition is increased by the cystitis, there may be no cessation day or night of the terrible sufferings.

Sometimes the pains are accompanied by spasm of the membranous urethra, and thus temporary retention adds greatly to the distress. In the most advanced stage, especially if the neck of the bladder have been partially destroyed by ulceration, there may be incontinence of urine.

Polypoid excrescences sometimes occur about the urinary meatus and urethra of women affected by tuberculous disease of the bladder.

*The Urine.*—With the onset of the frequency of micturition there is increase in quantity to three or four pints, but the urine remains clear; later it may become purulent with the cystitis. Tubercle bacilli are found in the first stage, but not when there is much pus.

*Diagnosis.*—Vesical tuberculosis ought to be suspected in any case in which frequency of micturition, with slight hæmaturia, occurs between the ages of fourteen and forty-five; especially if the patient have a tuberculous aspect or family history. If cystitis occur, and the presence of tubercle be ascertained in the lungs, generative organs, or other parts, the diagnosis becomes pretty certain.

Some nervous diseases may simulate tuberculosis of the bladder; but there will be other evidence of these, and the pains will precede the evidence of cystitis.

Vesical calculus presents a different form of hæmorrhage; and the symptoms are allayed by rest in the horizontal position.

Vesical tumours cause more copious hæmorrhage; and less marked frequency of micturition.

From cystitis due to other causes, tuberculous cystitis is distinguished by the onset and course of the disease, and by the result of examination of the urine. There may be some difficulty in making a diagnosis in



those cases in which the tuberculosis has followed an old gonorrhœa or a deep-seated urethral discharge.

From tuberculosis of the kidneys and ureters the diagnosis is often very difficult. The disease in the bladder progresses very much more slowly than in the kidneys. In cystitis the urine is at first, and for a long while, much less charged with pus, and that which is first passed contains more than the rest of the urine; and there are not the digestive disturbances, the dry tongue, and the rapid emaciation, which are produced by the renal disease.

In women the diagnosis is more difficult than in men. Hæmaturia, rather than frequency of micturition, is likely to be the first symptom noticed; the sexual organs do not give corroborative evidence, and cystitis is more often met with in women without obvious cause. Inoculation experiments and the inefficacy of general treatment will indicate the diagnosis. And, in doubtful cases of urinary tuberculosis, the thermometer seldom fails to assist us, as the temperature nearly always rises.

*Prognosis.*—The course of tuberculosis of the bladder is a slow one: acute attacks are frequently followed by periods of amelioration, and the disease may last some years. If the tuberculous process itself do not reach the kidneys, the end is generally brought about by pyelo-nephritis of the common suppurative form. Occasionally tuberculous peritonitis, acute phthisis pulmonalis, or acute general tuberculosis, is the immediate cause of death. Cold abscesses about the bladder, and the continued discharges from the resulting fistulas, help to wear out the patient.

*Treatment.*—Surgical treatment based on the radical extermination of the microbic cause of the disease has up to the present been disappointing.

The general and medicinal treatment in the early stages of the disease—as regards climate, diet, clothing, medicines, dry frictions, sulphur or salt baths, sea voyages, visits to the thermal springs, arsenical preparations, creasote, cod liver oil—are the same as in pulmonary phthisis. Articles ought especially to be avoided which, through the urine, irritate the bladder; such are all kinds of alcoholic stimulants, curries, spices, nux vomica, juniper, and so forth. Thus it is to medicinal, rather than to surgical means, that the patient should look for benefit.

Mercurial “instillations,” however, render great service. These instillations consist of the injection into the bladder of from 10 to 40 drops of sublimate solution, varying in strength from 1 in 5000 to 1 in 1000. It is claimed for this treatment that it acts not only as a medicinal remedy to relieve pain, but as a germicide to kill the microbes; and that its value is perceived in early stages by its success in relieving frequency of micturition.

If these means fail, and the bladder becomes very irritable and the pains severe, morphia must be liberally administered; even if required to the extent of several grains in the twenty-four hours. Of course the dose at first must be small, and the increase must be cautious and gradual; but very large doses will ultimately be tolerated.

Cystotomy should be the last resource, and only employed to relieve frequent and severe pain and irritability of bladder. The operation which hitherto seems to have afforded most relief has been supra-pubic drainage of the bladder, followed in some cases by the application of nitrate of silver, or chlorine of zinc, or sublimate solution (1 in 5000) to the seat of the disease.

**INJURIES TO BLADDER. — Rupture.** — Ruptures of the bladder are of three kinds: traumatic; idiopathic; and pathological.

*Etiology.* — The traumatic are caused either by violence from without, or by violent muscular efforts on the part of the patient herself: the pathological result from ulceration, sloughing, thinning, and sacculation of the parietes; the idiopathic result from the spontaneous yielding of the distended bladder, independently of any form of violence, or of previous ulceration, sloughing, or tunicary herniæ.

In rupture during labour the distended bladder is compressed between two strong muscular forces; namely, the contracting abdominal parietes and the contracting and enlarged uterus. In rupture during the struggles under anæsthesia, and during powerful muscular efforts, such as lifting or pushing, the bladder wall is passive and the rupturing force is in the abdominal parietes.

Traumatic ruptures form the bulk of the intraperitoneal cases and of those which are partly intraperitoneal and partly extraperitoneal.

True idiopathic ruptures, or those which occur when there is no disease, and where no violence was used, are very rare. In most cases of rupture during urinary retention the bladder gives way under forcible muscular efforts as explained above; so likewise in cases of rupture during heavy lifting, parturition, and muscular spasms. Thus this class is restricted to certain cases of rupture from simple over-distension by tumours, retroversion of the gravid uterus, and the like; to spontaneous rupture during alcoholism, erysipelas, fever, hysteria (Dr. J. B. Wilmont's case), and other serious illnesses; and finally to the fœtus in utero.

In pathological rupture the bladder, weakened at certain spots by ulceration or tunicary herniæ, gives way under distension; or it sloughs as the result of pressure or inflammation. Rivington collected 9 cases of intraperitoneal rupture from retroversion of the gravid uterus; 2 of intraperitoneal rupture from extra-uterine fetation; and 7 cases (3 intraperitoneal, 3 extraperitoneal, and 1 doubtful) due to ulceration.

Krukenberg, who has collected 10 cases of rupture from retroversion of the gravid womb, and added 1 observed by himself, considers the pathology of rupture of the bladder and gangrene of the vesical wall to be identical. In some cases protective adhesions on the peritoneal surface are formed during the progress of the gangrenous inflammation of the coats of the bladder, and then the gangrenous parts may be cast off entire or broken up; otherwise, perforation attends the separation of the slough, even without over-distension of the bladder. Rupture may also take place suddenly from over-distension before the separation of any

slough; or may result from efforts, even the most gentle and careful, to replace the uterus. Krukenberg adds that when retention of urine persists for ten days or longer, either gangrene or rupture of the bladder may occur; but rupture more frequently. He also gives the warning that, if gangrenous portions of the vesical wall have been cast off, no attempt should be made to replace the uterus; but that abortion ought to be induced.

The pressure of a retroverted gravid uterus has caused gangrene of the walls of the bladder in several instances.

*The Situation of the Rent.*—The posterior surface of the bladder is the common site, and the more or less vertical line the common direction of the simple intraperitoneal traumatic rupture. This rule, however, is subject to many exceptions. In spontaneous ruptures the rent is commonly behind, and is usually small and round.

The quantity of urine effused into the peritoneal cavity varies, and increases as life is prolonged. If death occur within three days a large quantity may be present without any signs of peritonitis. Surgical casualties in operations on the abdomen have repeatedly shown that healthy urine is harmless to the peritoneum, especially if it can find an exit; and, moreover, that it may be rapidly absorbed. Experiments, too, show the small quantity of urine injected into the peritoneum is inoffensive; that injections may be repeated with impunity; but that a persistent effusion excites peritonitis (Tuffier). On the other hand, when life has been prolonged, and septic elements have been introduced by the catheter, or have established themselves about the inflamed and contused edges of the wound, the evidences of peritonitis will be well marked.

*Diagnosis.*—The most certain evidence of intraperitoneal rupture is the entrance of a catheter into the peritoneal cavity through the rent in the empty bladder. In extraperitoneal rupture signs of urinary extravasation may appear soon; but in some cases they are not apparent for many hours.

The injection of a warm antiseptic solution into the bladder may be of great use in diagnosis; if the bladder is sound, the usual swelling of a distended bladder will be formed, and will disappear on the return of the fluid through the catheter.

*Prognosis.*—This is most grave. Walsham has collected 28 cases of intraperitoneal rupture of the bladder treated by sutures since 1888; of this number 11 recovered and 17 died. In only 1 out of the 11 successful cases was peritonitis present at the time of the operation; whereas in 8, and probably in 9, out of the 17 unsuccessful cases peritonitis had set in before the operation was commenced. The causes of death in the 8 cases in which peritonitis did not precede the operation were shock or hæmorrhage, or both combined, in 5; peritonitis from leakage in 2, if not in 3. In 4 out of 17 cases the rent had not been securely closed and leakage occurred.

*Treatment.*—The first thing in many cases will be to attend to the condition of extreme shock by the application of warmth, gentle

stimulation, and the like, requisite in all such cases. Next must be the prompt local treatment to prevent the further escape of urine into the peritoneum or pelvic cellular tissue by providing a ready exit for the urine as it reaches the bladder by catheter; and by closing the wound in the bladder by sutures when this is possible. And here everything depends upon an early and an accurate diagnosis. If the case be one of intraperitoneal rupture no time is to be lost (where sufficient assistance and proper convenience can be obtained for the operation) in performing laparotomy, clearing out the urine and blood from the peritoneal cavity, and securely suturing the opening in the bladder wall.

When the surgeon is single-handed, and cannot get assistants or appliances within twenty-four hours, let him employ antiseptic drainage of the bladder from the outset, and reduce to a small limit the quantity of fluid given to the patient for the first three or four days. Paracentesis of the abdomen or recto-vesical pouch need hardly, if ever, be performed.

In extraperitoneal ruptures a catheter should be retained in the bladder with the most rigid antiseptic precautions, taking care that the instrument is large, and that the urine is run off into a vessel, containing an antiseptic solution, placed beneath the bed.

**Vesico-vaginal Fistula.** — A communication between the bladder and either the uterus or vagina, so as to admit of the more or less continuous escape of urine, is a condition productive of extreme distress. The size of the opening varies from that of a pin's point to a diameter of an inch or more. When recent the aperture is usually at its largest, diminishing later by cicatricial contraction. At the same time the bladder shrinks, and the walls are contracted and thickened. Sometimes the mucous membrane of the bladder can be seen to protrude through the opening in the vesico-vaginal septum. The urethra is often considerably narrowed, as a result of disuse, and the edges of the fistula are thickened and sometimes held apart by cicatricial fibrous tissue.

*Etiology.* — By far the commonest cause of communication between bladder and vagina is cancer of the cervix uteri extending to the septum, and causing destruction of it. When the disease has reached this stage it is beyond the power of remedies; it only remains to adopt measures for soaking up the escaping urine and protecting the skin. Fistula developing in connection with parturition belongs to a different category. It results either from direct laceration or, more often, from sloughing, following continued pressure of the fœtus within the pelvis. Other less frequent causes are necrosis attending diphtheritic inflammation of the bladder, and ulceration produced by the long continued pressure of a pessary in the vagina.

*Symptoms.* — These are chiefly due to the escape of urine by the vagina and the consequent irritation of the skin. Besides these, however, amenorrhœa, sterility, and constipation are usually present, with great impairment of the general health.

The *diagnosis* is generally easy. Where the apertures are small or



concealed the bladder should be distended with milk or some coloured fluid, while the vagina is carefully inspected by means of a speculum.

*Treatment* consists in paring and suturing the edges, after fully exposing the site of the lesion, and in draining the bladder till they have united. [*Vide* article on Plastic Operations, p. 772.]

**Foreign Bodies.**—Foreign bodies gain access to the cavity of the bladder (i.) through the urethra; (ii.) when forced through its walls by injury; (iii.) by means of ulceration, or the formation of a fistula, which is most often of cancerous origin.

In the first category, by far the greater number are substances introduced by patients either to allay itching or for some aimless or sensual purpose; the variety of things which have been so introduced is almost endless. In the second are found bullets, pieces of bone or of raiment, or buttons. Foreign bodies which ulcerate into the bladder, or find their way along fistulous tracts, come either from the vagina, the rectum, or the higher intestines, from extra-uterine gestation cysts, from dermoid cysts, or from abscesses in the pelvic cellular tissue.

In this way vaginal pessaries have passed through the vesico-vaginal septum; pieces of horn, coins, faecal matter, and intestinal worms have entered from the bowel; fragments of a foetus in extra-uterine gestation; hair and teeth from dermoid cysts; hydatids; and pus and bone from pelvic abscesses.

From the observations of Guyon and Henriët it appears that, when once fairly within the cavity of the bladder, foreign bodies occupy most frequently a transverse position between the summit and the neck of the bladder, and rather nearer the neck. In the empty bladder this position is more constant than in the full bladder; in the empty bladder it is the only position which bodies not longer than ten centimetres can take. Smaller bodies can occupy any position in the distended bladder; but in the empty, or nearly empty organ, they assume the line of the transverse diameter. A body of twelve centimetres in length takes a vertical position, or, if one of its ends is buttressed near the neck, it may lie obliquely. Light bodies float; hollow ones, such as a piece of tubing or of a catheter, generally lie in the base of the bladder. Some become disintegrated and are passed in particles, perhaps even without the patient's knowledge.

Foreign bodies, when in the bladder, may remain entirely quiescent, or they may excite cystitis; after a time they may cause ulceration and perforation, and, giving rise to a perivesical abscess, may escape by the direction through which the abscess is either opened or spontaneously discharged. Or the foreign body, having penetrated the vesical wall, may remain partly within the bladder and partly within the peritoneal cavity. The foreign bodies become encrusted with phosphates, and are then often the nucleus of a stone. This deposition begins, in some instances even within twenty-four hours, upon the largest part of the foreign body and proceeds towards the extremities; these parts, however, never become encrusted.

*Symptoms* may be entirely absent; but, as in the case of calculus, the rule is for the patient to have pain and frequent micturition, and possibly to discharge a little blood at the end of micturition. Hair and other rough or sharp bodies are apt to excite cystitis with its attendant cardinal symptoms.

If the foreign body penetrate the cellular tissue and form an abscess in the pelvis, the local and constitutional signs of inflammation and suppuration ensue. If they penetrate into the rectum there will probably be rectal tenesmus; if into the peritoneum or small intestines, signs of peritonitis will most likely occur.

*Diagnosis.* — When the foreign body has been introduced by the patient the readiest road to a correct knowledge of the case is the frank admission of the patient; but she often denies any knowledge of what she herself has done.

In surgical accidents, such as catheters breaking off in the bladder, there is no room for doubt. In traumatic cases there is the history of the injury and the presence of a wound or scar. In perforation of the vaginal septum, there is the history of local pain, and probably the existence of the ulcerated aperture or its scar. When the foreign body has passed through from the intestinal tract there may be, or may have been, the escape of gas, fæces, or ingesta along the urethra.

In the case of hysterical women, however, it is necessary to bear in mind that all sorts of things are designedly mixed with the urine.

Hydatids passed with the urine will give the clue to their presence in the bladder.

It is of great importance, especially with a view to its extraction, to learn, if possible, the shape and size of the foreign body, and the length of time it has been lodged in the organ. In all cases of doubt the surgeon should examine the bladder (*a*) by the finger in the rectum, in the vagina, or passed into the bladder through the dilated urethra, (*b*) by sounding, and (*c*) by the cystoscope.

*Treatment.* — If the foreign body has been recently introduced, and it is soft and pliable, like a piece of tube or gum-elastic catheter, it can readily be extracted by the lithotrite, no matter how it is seized by the blades of the instrument. Hard, rounded bodies can also be easily extracted by the lithotrite; either with or without breaking them into fragments. Elongated substances, whether blunt or sharp, give great trouble because of the difficulty of catching them in their long axis. The cystoscope will often be of great value in this respect by informing us of the direction in which the body lies. Some bodies, such as a hairpin, for example, may be luckily caught at their curved ends and withdrawn by means of a blunt hook at the end of a flexible stem.

When the foreign body has become encrusted with calculous matter, some advise that the deposit should be detached by the lithotrite, and the foreign body extracted in the same manner as if it had only recently been introduced; and that the calculous matter should then be removed as in litholapaxy. This, however, is by no means always easy; and sometimes

it is quite impossible to detach the calculous matter thoroughly from the foreign body: on the whole, it is the better practice in most cases of calculous formation to remove the foreign body by operation, without attempting the double procedure with the lithotrite and extraction instrument.

Bodies, such as twigs of trees, are very dangerous, as they are liable to be broken, and their leaves or broken particles may cling to, or stick into the mucous membrane, whence they cannot be dislodged either by instruments or irrigation. Cystitis is very apt to arise and to be followed by ascending suppuration and death from pyelo-nephritis. This complication, of course, may occur in the case of other foreign bodies.

In women it will be rarely necessary to resort to any cutting operation, as the dilatibility of the female urethra allows the extraction of most foreign bodies which can enter the bladder.

After extraction the treatment is the same as after extracting an ordinary calculus, and will vary according to the presence or absence of cystitis.

NEOPLASMS. — New growths of the bladder present numerous histological varieties and considerable clinical differences. Clinically, some are benign and others malignant; histologically, the benign comprise papilloma, myxoma, fibroma, and myoma. The malignant are carcinoma and sarcoma.

The following table shows the relative frequency of malignant and non-malignant new growths in the bladder: —

	Total.	Males.	Females.
Cancer . . . . .	59	43	16
Sarcoma . . . . .	6	5	1
Fibroma . . . . .	2	1	1
Papilloma (villous) . . . . .	23	21	2
	<u>90</u>	<u>70</u>	<u>20</u>

There are some characters common to all bladder tumours. Their usual situation is about the trigone and the orifice of the uterus. Benign tumours are generally rounded, often polypoid or tufted; the malignant tumours are more generally spread out.

Their size varies from that of a cherry to that of an egg; larger growths are rare, and are generally myoma.

Cancerous and sarcomatous tumours are not unfrequently multiple, the masses being apparently independent of one another.

Tumours may be embedded in the vesical wall, or sessile, or pedunculated on its surface; or they may infiltrate it.

*Papilloma* is of two kinds, the fimbriated or "villous polypi," and the fibro-papillomas, or "papillary tumours." In the villous polypi the stalk sends off numerous branches and sub-branches of polypi, which consist of a capillary vessel covered by a basement membrane and a

more or less thick layer of epithelium; in the papillary tumours the stroma is compact and has a dense fibrous or muscular structure, amongst which may be found embryonal cells and leucocytes. The villous polypi are very frequently multiple, and form tufts or feathery bunches of varying lengths more or less spread over the mucous surface; these float in the urine. When very long their extremities are often carried into the urethro-vesical orifice during micturition and are there nipped by the sphincter: this is a cause of considerable suffering. There is no infiltration of the vesical wall about their points of attachment. The papillary tumour or "fibro-papilloma" may be single or multiple; it is generally rounded in shape, and of the size of a pea, a cherry, or a walnut. It is more often sessile than pedunculated; its surface is villous, but its consistence is firm.

*Myxoma* is in reality a "fibro-papilloma," or a fibroma, the cell portions of which have undergone a mucoid degeneration. These tumours are soft in texture, grow rapidly, and are met with most frequently in young children. They are probably often congenital, frequently multiple and pedunculated; their common situation is near the neck of the bladder, and they may extend into the urethra.

*Fibroma* originates in the deep mucosa or in the muscular layer, and is covered by normal epithelium. Like myxoma, these growths are pedunculated; but they occur in adults, and have not yet been found in children. They are very rare.

*Myomas* are rare; two cases reported by Belfield show indisputably that they may arise from the vesical wall. They occur as nodules encapsuled in the submucosa; they may be composed either of unstriped muscular fibres (myoma), or of this mixed with fibrous tissue.

*Sarcoma* is comparatively rare, but its rarity has probably been greatly exaggerated.

*Carcinoma*.—Two varieties are met with: (i.) epithelioma, that is, squamous-celled carcinoma, or cylindroma; and (ii.) glandular-celled carcinoma, either encephaloid or scirrhus. Colloid degeneration of the glandular-celled carcinoma may occur, but is rare.

Secondary carcinoma is more frequent than primary, and may be consecutive to cancer of the rectum, vagina, or uterus. These tumours form prominent, irregularly rounded swellings, widely attached, and infiltrating the vesical coats more or less deeply. Their surface is granular, and in the later stages is ulcerated; occasionally they present gaping ulcers with raised and indurated walls. They are hard, but friable; and therein differ from the softer but little friable fibro-papillomas. They are often multiple, and are most common in the trigone or base of the bladder. They develop slowly, seldom ulcerate early, and cause death before they attain any great size; often before they are followed by secondary growths in distant organs.

Some tumours which have been exceptionally found in the bladder are adenoma, angioma, serous cystoma, and dermoid cystoma. The latter is probably due either to an abnormal development of the bladder wall,



by which a portion of the epiblast fills in a deficiency, or they are perivesical in origin.

*Mucous polypi*, having a texture resembling that of ordinary nasal polypus, except that the epithelial covering is squamous instead of ciliated, have been found in the bladders of children under two years of age, as well as in adults. In the early stage they may not give rise to any symptoms; later they may simulate vesical calculus, and growing to a considerable size project even beyond the urethra, or distend the bladder to the level of the umbilicus.

*Bilharzia hæmatobia* sometimes causes masses of fungating exudation of considerable size in the bladder. It is not an uncommon cause of hæmaturia in the Nile district. [Art. "Bilharzia" in *Syst. of Med.* vol. ii.]

*Pathological complications* of bladder tumours are: (i.) local thickening of the bladder walls due to hypertrophy of muscular and interstitial tissue; (ii.) hydronephrosis; (iii.) calcareous deposit on the surface of the tumour; (iv.) occasionally a phosphatic calculus free in the bladder, the result of a cystitis provoked by the growth, possibly a portion of the growth broken away from the rest may form its nucleus; (v.) suppurative pyelo-nephritis with or without distension of the kidney.

*Symptoms.*—Bladder tumours are met with at all ages, the sarcomas and myxomas in children; cancer between forty and sixty. They are much more common in men than in women.

A small number of tumours of the bladder are quite unsuspected during life, as large calculi have been found as a surprise in autopsies. But as a rule their presence is made only too apparent by hæmorrhage, pain, frequency of micturition, and, not infrequently, by the presence of a swelling felt either through the vagina or through the anterior abdominal wall. Hæmaturia is by far the most constant symptom; in some cases it is the only one, and sometimes is alone the cause of death. It is nearly always the first symptom complained of, and the one which brings the patient to his doctor. Its onset, its course, and its abundance are characteristic of tumour. It comes on spontaneously without injury, fatigue, or even movement; and it causes no difficulty in micturition unless a clot for a while obstruct the urethra. It may be excited by catheterism or by distension of the bladder; and rest even in the recumbent position has no effect in stopping it. After the hæmaturia has existed for hours, days, or weeks, the urine may suddenly become quite clear.

Whilst the hæmaturia lasts, the urine is not equally charged with blood at each micturition; more blood is passed at the end of micturition than at any other period of its flow: the quantity is often exceedingly great, and the loss, even from a small innocent growth, may be fatal. In cases of repeated or prolonged hæmorrhage the patient becomes anæmic and waxen looking, and the lower extremities œdematous.

Pain is not a constant symptom; it appears late, and is generally due to cystitis. When it exists it is often very intense, and is worse at the end of micturition. It is felt in the hypogastrium and at the neck of the

bladder, and radiates down the thighs. But, except from cystitis, from nipping of the growth by the sphincter vesicæ, or from retention due to clots of blood, pain occurs only when the growth is pressing upon the nerves as it infiltrates the bladder wall.

*Physical signs* are those ascertained by abdominal or vaginal examination, by the endoscope, by injecting fluid into the bladder to the degree of distension, and by the catheter. If these means afford positive signs, well and good; but if not, we must not exclude tumour from our diagnosis, if the above described functional symptoms be present, especially hæmaturia. With the patient lying on her back, with her knees and shoulders raised, we can, in a thin person, sometimes feel the tumour through the abdominal walls immediately above the pubes. Still more frequently can it be felt by vaginal examination, especially if at the same time the bladder be firmly pressed upon by the left hand applied on the hypogastrium. The result of this kind of examination may be positive or negative. It may be negative if the growth be either villous polypus or fibro-papilloma, or a small pedunculated myxoma-fibroma; but if we feel an irregular nodular or infiltrated vesical wall or thickened mass above the neck of the bladder, we know the disease is malignant. Mucous polypi, when large and abundant, have also been felt on the application of pressure to the hypogastrium.

It is well always to examine the urine first passed after this kind of examination; for when tumour is present the examination is often followed by slight hæmorrhage.

The catheter and sound ought to be used with the greatest care; not only as to their aseptic condition, but with deftness so as to avoid bruising the tissue of the tumour and provoking hæmorrhage.

*Diagnosis.*—This can generally be made pretty accurately (1) by the character of the hæmorrhage; (2) by the physical signs described above; (3) by the cystoscope or tube which in certain cases enables the new growth to be actually inspected; (4) in the woman, by digital examination per urethram, which affords absolute certainty as to the presence or absence of growths, even the smallest; and this should be preferred to all other methods.

If a tumour of some weight or volume be detected, or a general thickening or infiltration of the base of the bladder exist, we conclude that the growth is malignant, and the prognosis very serious.

The distension of the bladder with a solution of boric acid or weak carbolic solution, if it excite hæmorrhage as the last drops flow away, is a valuable diagnostic guide to the vesical origin of hæmaturia. Sometimes, especially if the growth be near the neck of the bladder, a drop or two of blood flows through the injection catheter, either as it enters the vesical cavity or as soon as the injecting process ceases.

The cystoscope in some cases gives most valuable information; but it is useless in cases in which there is blood in the bladder, and it ought not to be used upon all patients indiscriminately.

The chief difficulty in most cases is to determine whether the

hæmaturia be of renal or vesical origin. This may be decided by the presence of local signs in the renal or vesical regions, by the presence of renal or ureteral casts, and by a consideration of the several symptoms. The difficulty is accentuated when both regions, or neither, yield positive evidence. We must then have recourse to distension of the bladder, or sounding; if this provoke hæmorrhage we have proof of vesical disease.

From the hæmorrhage attending acute and chronic cystitis, tubercular disease of the bladder, and calculus, the diagnosis will be readily made by a careful attention to the history of the case, and to the cardinal symptoms of the respective diseases.

There are cases of hæmaturia in which it is impossible to be sure of the source of the bleeding; in some it is due to congestion and varicosity of the vessels of the bladder.

*Prognosis.*—This is always serious. The malignant growths are unfavourable for removal, as they infiltrate the vesical walls and quickly recur. The benign tumours are often easily removable; but some, especially the villous polypi, are prone to come again. Then there is the danger from hæmorrhage, which may be fatal; from cystitis running on to pyelo-nephritis, or from intermittent hydronephrosis. These causes of death arise from innocent as well as from malignant growths.

As to the duration of life, Féré gives for malignant tumours eighteen months to two years, Barling three years; whereas Guyon has operated upon patients for epithelioma in cases in which the first symptoms of bladder tumour dated back ten years previously. Such cases indicate either that cancer progresses much more slowly in the bladder than elsewhere, or that tumours, benign at first, can subsequently become malignant. We know this to be the case in uterine myoma, and in tumours of other kinds in other parts of the body.

Vesical malignant growths infect other parts or organs but slowly; death is by no means invariably due to secondary invasions.

The benign growths may go on for years, causing only occasional hæmorrhage at longer or shorter intervals, and of greater or less severity. I have known cases go on for ten years or more; and when at last an operation has become absolutely necessary, a mass of villous polypi enough to fill a breakfast cup has been removed.

Tumours of the bladder, if left alone, almost always cause death; though their progress, especially in the benign cases, may be very slow. It is mostly by hæmorrhage that the fatal result is brought about; in other cases by pyelo-nephritis, the sequel of cystitis.

*Treatment.*—The best palliative means are incision and drainage of the bladder; the only curative means is, of course, excision of the tumour.

In woman the best incision for palliative purposes is through the vesico-vaginal septum; sutures should unite the vesical with the vaginal mucous membrane over the edges of the incision, so as to secure a permanent opening.

When the bladder wall is not largely involved, and if the condition

of the kidneys does not forbid, the curative treatment should be carried out if possible; if, however, after opening the bladder, the disease is found to be too extensive for removal, the surgeon must fall back upon palliative means.

When a growth is felt, per vaginam or with the sound, to involve a large surface of the bladder wall, and to be infiltrating its coat, especially in the neighbourhood of the ureters and neck of the bladder, no operation whatever should be proposed unless the hæmorrhage be copious or the symptoms of cystitis severe; then an incision, for palliative purposes only, should be made. This should be the vesico-vaginal boutonnière. By these means we place the bladder at rest; thus, by drainage, we remove the septic urine from an inflamed bladder; and, by preventing the alternation of distension and contraction of the bladder which is the chief cause of the bleeding, we check the hæmaturia. When the disorganised state of the kidneys is unfavourable to any prolonged operation, the vaginal drainage is still indicated to check hæmorrhage, or for the relief of the sufferings caused by cystitis.

Urethral dilatation enables many tumours to be removed easily and thoroughly through the canal; and as the urethra can be dilated to between two and three centimetres without fear of after ill consequences, this route is the most satisfactory for the majority of cases suitable for curative treatment. Where the growth is too large to be removed through the female urethra, hypogastric cystotomy should be performed. It must suffice here to say that the methods for removing the growths are by—(a) tearing them away, (b) crushing them off with forceps or ecraseur, (c) curetting, (d) cauterisation, (e) excision with the bistoury and closing the wound in the mucous membrane by sutures, or searing the surface with the cautery, (f) torsion.

Tuffier records 43 operations through the urethra without a death, and 5 suprapubic operations all successful.

**STONE IN THE BLADDER.**— Vesical calculus is rare in women, because owing to the shortness and dilatibility of their urethra, calculi which can traverse the ureter can easily escape from the bladder. Moreover gravel and gout are much less frequent in women than men.

Local causes of the formation of stone in the bladder are all those which tend to the stagnation of urine in the bladder and to the development of cystitis. When these two conditions, decomposition of urine and cystitis, occur together, as so often they do, the ammonia-magnesian phosphates are precipitated. This precipitation may occur spontaneously, and thus lead to the formation of a primary vesical calculus; or it may take place even more readily around a concretion which has descended from the kidney; and this is the process by which uric-acid calculi become enveloped in a white casing of the phosphates.

It is by this same precipitation of the phosphates that foreign bodies in the bladder become encrusted with salts, and calculi are formed with such things as blood-clots, pieces of bone, hairpins, twigs of trees, berries,



and so forth, as their nuclei. In the same way, too, the surface of vesical tumours and the ends of catheters retained in the bladder become encrusted with a more or less thick white layer.

*Chemical Composition.*—There are three chief classes of vesical calculi: (i.) The most frequent are formed of uric acid and its combinations; (ii.) the next in frequency of phosphoric acid in combination with volatile alkali and the alkaline earths; and (iii.) those of oxalate of lime.

*The symptoms* are pain, frequency of micturition, and hæmorrhage. To these may be added—(a) the sudden interruption of the stream of urine, a symptom to which, however, undue importance is often given; (b) the patient's clinical history, especially as to the passage of gravel or sand; and (c) the previous occurrence of an attack of nephritic colic, not followed by the discharge of a calculus.

Examination per vaginam enables us to feel a stone or stones, and also to judge as to their number and size; especially when firm pressure is made on the bladder above the pubes. But it is by means of the sound that we gain the more precise information.

*Prognosis.*—The supervention of septic infection of the bladder, whether any operation have been done or not, creates the danger of calculus, and, as ascending suppurative pyelo-nephritis, conduces to the fatal result. The existence of this condition before the operation adds largely to the risks of surgical interference, and to the prevention of it is attributable the mortality, small though it be, which follows lithotripsy as now practised by skilled hands.

The spontaneous expulsion of calculi in the case of men cannot be reckoned upon; but women pass large stones through the urethra, and others still larger sometimes escape into the vagina by ulceration of the vesico-vaginal septum.

*Treatment.*—In women, owing to the absence of the prostate, lithotripsy is said to be more difficult than in man; but this applies only to the operation in hands inexperienced in lithotripsy in males. Lithotripsy is, however, rarely required in women, because of the capacity and dilatibility of the urethra. In women with stone of a large size vaginal cystotomy, followed by immediate sutures, is an easier, safer, and more satisfactory operation than the hypogastric operation. In female children, the best operation is lithotripsy by means of a lithotrite of the calibre of a full-sized catheter (No. 12 or 14), followed by the evacuation of the fragments with Clover's or Bigelow's evacuating bottle (aspirator); and in adult women the same operation may be employed for stones which are too large to be safely extracted through the urethra in their entire state. Or the fragments of the stone may be removed with forceps through the dilated urethra. The operation is allied to the mixed operation in males.

HENRY MORRIS.

## REFERENCES

1. *American Journal of Obstetrics*.—2. *Annales des maladies des organes genito-urinaires*.—3. *Archives fur Gynaecologic*.—4. BAVOUX, H. *Des polyypes de l'urèthre chez la femme*. Strasbourg, 1844.—5. BRECHOT, A. *Des tumeurs de l'urèthre chez la femme*. Paris, 1876.—6. CIVIALE. *Maladies des organes genito-urinaires*.—7. DAUTIN, E. *Du diagnostic de quelques écoulements urèthraux chez la femme*. Strasbourg, 1869.—8. DELL'ACQUA, P. *Historia Phlegmhymen proptoseos urethræ*. Ticini Regii, 1830.—9. DOLLEZ, C. A. *Des polyypes de l'urèthre chez la femme*. Paris, 1866.—10. DUPIN, O. P. *Sur les végétations hémorrhoidales de l'urèthre chez la femme*. Paris, 1873.—11. EHRHARDT, E. *Ueber chronische Ulcerationen an der weiblichen Harnröhre*. Berlin, 1884.—12. ÉTIENNE, P. *De l'urèthre de la femme, etc.* Nancy, 1880.—13. FANTORIE and MOLLINETTI. *Phil. Trans.* vol. vii.—14. FISSIAUX, E. *Des rétrécissements de l'urèthre chez la femme*. Paris, 1879.—15. FLEYSSAC, C. E. *De quelques tumeurs de l'urèthre chez la femme et principalement des tumeurs hémorrhoidales*. Paris, 1879.—16. FLOTARD, D. *De la dilatation de canal de l'urèthre chez la femme*. Montpellier, 1882.—17. GANT. *Diseases of the Bladder, Prostate Gland, and Urethra*. London, 1884.—18. GOTTSCHALK, S. *Ueber die weibliche Epispadie*. Würzburg, 1883.—19. GUÉBHARD. *Étude sur la cystite tuberculeuse*. Paris, 1878.—20. GUYON, J. C. F. *Leçons cliniques sur les affections chirurgicales de la vessie et de la prostate*. Paris, 1888.—21. HACHE. *Étude clinique sur les cystites*. 1884.—22. HARRISON, R. *Ashurst's Surgery*, vol. vi. 1886.—23. HARTMANN. *Des cystites douloureuses et de leur traitement*. Thèse, 1887.—24. MAUER, OTTO. *Ueber die Erfoliation der Blasenschleimhaut*. Berlin, 1880.—25. MAURICE, V. *Histoire de la dilatation rapide de l'urèthre chez la femme*. Nancy, 1877.—26. MORRIS, H. *Injuries and Diseases of the Genital and Urinary Organs*. London, 1895.—27. MÜNZNER, M. *Ueber Vorfal der Schleimhaut der weiblichen Harnröhre*. Ehrlangen, 1858.—28. NITZE, M. *Kystophotographischer Atlas*. Wiesbaden, 1894.—29. NOTTA. "Observations de corps étrangers introduits dans la vessie et dans le canal de l'urèthre," *Année méd.* 1877-8-9. Caen.—30. NUNEZ, J. E. *Étude sur les vices de conformation de l'urèthre chez la femme*. Paris, 1882.—31. PICARD, H. *Traité des maladies de la vessie et des affections calculeuses*. Paris, 1878.—32. PIEDPREMIER, F. *Contribution à l'étude des maladies de l'urèthre chez la femme; wréthrocèles vaginales*. Paris, 1887.—33. REICHELT, P. W. *Ueber Prolaps der Uretralschleimhaut beim Weibe*. Halle a. S. 1886.—34. SILBERMANN, O. *Die brüske Dilatation der weiblichen Harnröhre*. Breslau, 1875.—35. SKENE. *Diseases of the Bladder and Urethra in Women*. New York, 1878.—36. SOULLIER, L. *Du cancer primitif du méat urinaire chez la femme*. Paris, 1889.—37. THOMPSON, Sir H. *Tumours of the Bladder*. London, 1884.—38. TRITSCHLER, E. *Ueber der Vorfal der Schleimhaut der weiblichen Harnröhre im kindlichen Alter*. Tübingen, 1891.—39. TUFFIER. *Appareil urinaire. Traité de chirurgie. Duplay et Reclus*. Paris, 1892.—40. UEBERSCHUSS, H. *Beiträge zu der Lehre von den primären Carcinomen der weiblichen Urethra*. Würzburg, 1892.—41. VOILLEMIER, A. le D. *Traité des maladies des voies urinaires*. Paris, 1881.—42. WALSHAM. *Royal Med.-Chir. Soc.* 11th June 1895.—43. WEST and DUNCAN. *Diseases of Women*. London, 1879.—44. WINCKEL. "Die Krankheiten der weiblichen Harnröhre und Blase," *Billroth's Handbuch*. Stutgard, 1877.
- Tumours of the Urethra.—HENRY, A. F. Paris, 1858.—JONDEAU, A. Paris, 1888.—KEILMANN, H. Würzburg, 1886.—LEMOINE, V. Paris, 1866.—MENETREZ, A. Paris, 1874.—MOUTON, E. G. Paris, 1876.—THEVENON, L. A. Paris, 1879.—VELTEN, P. F. Paris, 1862.—WEISGERBER, A. Paris, 1877.

H. M.

## LIST OF AUTHORITIES

- ABEL, 652, 694, 728, 732  
 Ackermann, 605  
 Adam, 642  
 Adami, 445  
 Adams, 411  
 Aetius, 22  
 Agnew, 929, 930  
 Aitkin, 535  
 Alexander, 18, 411  
 Allbutt, 7, 224, 249, 341  
 Allingham, 263  
 Amann, 420, 843  
 Amussat, 604  
 Anderson, 487  
 Ansell, 563  
 Apostoli, 13, 14, 28, 300, 305, 306, 307,  
     316, 321, 322, 324, 325, 329, 333, 335,  
     336, 597, 598  
 Aran, 486, 554, 919  
 Asch, 549  
 Aslanian, 592  
 Atlee, 10, 604  
 Atthill, 209, 264, 265, 293  
 Auteureich, 841  
 Auvard, 295, 679, 687  
 Aveling, 29, 341, 923, 924  
  
 BAER, 621, 622, 623, 624, 628  
 Baff, 891  
 Baldy, 297, 298, 531  
 Ballance, 269  
 Ballantyne, 812  
 Bandl, 4, 534, 535, 539, 546, 547, 552, 799  
 Bantock, 12, 276, 584, 622  
 Barbour, 3, 4, 23, 534, 535, 544, 771  
 Bardenhauer, 621, 627  
 Barling, 955  
 Barlow, 534  
 Barnes, 209, 250, 253, 277, 293, 472, 525,  
     532, 533, 539, 915, 919, 920, 922  
 Barrier, 920  
 Barrow, 276  
 Barth, 801, 805, 813, 816, 824  
 Battey, 11, 601  
 Baudry, 435  
 Bayle, 562  
 Bayliss, 342  
 Beau, de, 339  
  
 Becqueril, 528  
 Beidel, 384  
 Beigel, 528  
 Belfield, 952  
 Bell, 8, 295, 873  
 Benicke, 370  
 Bennet, 5, 189, 190, 199, 211  
 Bernard, 341  
 Bernardet, 936  
 Bernays, 586  
 Bernhardt, 707  
 Bernutz, 22, 23, 486, 525, 526, 527, 528,  
     531, 532, 534, 535, 536, 540, 555  
 Berry, 341  
 Beyea, 794  
 Bickersteth, 806, 807  
 Bigelow, 957  
 Billroth, 19  
 Birschoff, 383  
 Blanc, 447  
 Blau, 697  
 Blot, 67, 71  
 Blundell, 639, 700  
 Bodd, 342  
 Boinet, 872  
 Boldt, 592  
 Bouchart, 340  
 Bourdon, 22, 524  
 Bozeman, 286, 477, 599, 773, 778  
 Braithwaite, 281  
 Brandt, 405, 522  
 Braun, 209, 525, 546, 550, 557, 654  
 Breisky, 384  
 Brennecke, 192, 712  
 Breslau, 525  
 Breunicke, 622  
 Broers, 443  
 Brown, 230  
 Brown, Baker, 8, 603  
 Browne, 921  
 Bryan, 942  
 Bücheler, 694  
 Buck, 290  
 Buckmaster, 94  
 Budin, 285, 286  
 Bumm, 207, 660  
 Bürkle, 694  
 Burns, 19

- Busch, 68  
 Busey, 918  
 Byford, 624  
 Byrne, 528  
  
 CABADE, 341  
 Cabot, 577  
 Calvi, 22  
 Campbell, 339, 340, 472  
 Caradic, 91  
 Cart, 798  
 Carter, 465, 480  
 Casati, 341  
 Cavallini, 639  
 Chaffey, 793, 794  
 Chambers, 277, 278, 871  
 Chambon, 873  
 Championnière, 809  
 Champneys, 28, 29, 281, 362, 469  
 Chapman, 257, 342  
 Charcot, 224  
 Charrier, 594  
 Chassaingnac, 543  
 Cheston, 472  
 Chiari, 715  
 Chiarleoni, 91  
 Choux, 798  
 Chrobak, 621, 624, 626, 627  
 Church, 18  
 Churchill, 22, 200, 263  
 Civiale, 936  
 Clark, J., 18  
 Clark, Sir Charles, 18, 19  
 Clay, 8, 10, 873  
 Clover, 283, 631, 764, 919, 957  
 Coblenz, 62, 805  
 Coe, 800, 824, 825  
 Cohnstein, 711, 713  
 Collins, 289  
 Colomiatti, 71  
 Colucci, 293  
 Conheim, 563  
 Cook, 341  
 Cooke, 476  
 Cornil, 204, 205, 214, 215, 679, 822, 823  
 Courty, 293, 925  
 Coussat, 590  
 Cramer, 102  
 Crampton, 911, 914, 917  
 Crédé, 525, 552, 912  
 Cripps, 268  
 Crosse, 912, 915  
 Cruveilhier, 573, 585, 592, 841  
 Cullen, 796, 799  
 Cullingworth, 24, 35, 534, 571, 590, 793,  
     818, 819, 820  
 Cusco, 274, 275  
 Cutter, 325  
 Czempin, 192, 346  
  
 DARWIN, 113  
 Delépine, 681  
  
 Delaporte, 873  
 Demons, 808, 809  
 Denver, van, 341  
 Depage, 74, 75  
 Dessaignes, 434  
 Dezeimeris, 463, 464  
 Diamant, 341  
 Döderlein, 207, 385, 623  
 Dodd, 342  
 Doherty, 22  
 Dolbeau, 535, 545  
 Doleris, 286, 797, 805, 810, 811, 820, 876  
 Doran, 12, 16, 25, 66, 85, 470, 471, 506,  
     810, 811, 816, 840, 842, 845, 846, 848  
 Doyen, 621, 628  
 Dubois, 932  
 Du Chemin, 582  
 Dudley, 623  
 Duffin, 8  
 Dührssen, 57, 522, 724, 764, 765, 768  
 Duke, 290, 295, 752, 754  
 Duncan, Matthews, 7, 22, 23, 25, 27, 98,  
     195, 201, 232, 236, 263, 282, 374, 429,  
     433, 435, 452, 485, 525, 528, 533, 543,  
     544, 547, 557, 573, 606, 730, 852, 853,  
     860, 913, 914, 920  
 Duncan, W., 693  
 Dupuytren, 899, 900, 932  
 Durand, 96  
 Dwight, 92  
 Dybowski, 697  
  
 EARL, 820  
 Eastman, 621, 624, 626, 627  
 Eberth, 804, 814, 816  
 Edebohls, 627  
 Edelmann, 304  
 Edge, 522  
 Edmunds, 269  
 Eisenmann, 75  
 Ellinger, 288, 364  
 Embling, 341  
 Emmet, 77, 189, 201, 218, 497, 533, 541,  
     563, 600, 604, 677, 748, 756, 763, 765,  
     766, 767, 768, 772, 774, 776, 919, 924  
 Englemaun, 27, 366  
 Eve, 799  
  
 FABRICIUS, 816  
 Falk, 69  
 Fantoni, 929  
 Farre, 49, 389  
 Fasbender, 370  
 Fearn, 813, 818  
 Fehling, 589  
 Fénerley, 525, 533  
 Fére, 955  
 Fergusson, 264, 266, 908  
 Ferraresi, 70  
 Fischel, 197, 198, 846  
 Fitch, 877, 883  
 Flaischlen, 846



- Flower, 44  
 Fochier, 740  
 Fordyce, 91  
 Formad, 825  
 Fowler, 447  
 Frankenhäuser, 552  
 Frank, 95  
 Franklin, 476  
 Freund, 426, 428, 430, 585, 700, 712, 761, 850, 919  
 Fritsch, 20, 209, 214, 215, 286, 290, 362, 531, 599, 622, 692, 698, 705, 706, 714, 722  
 Frommel, 805  
 Führer, 846  
 Fürst, 73, 84, 731  
  
 GALABIN, 282, 476, 924  
 Gallard, 531, 533  
 Garceau, 519  
 Gardner, 290  
 Gariel, 919, 922  
 Geddes, 113  
 Gegenbauer, 114  
 Gemmel, 583  
 Gervis, 294  
 Godart, 811  
 Godlee, 825  
 Godson, 282, 479, 638  
 Goelet, 336  
 Goffe, 623, 624  
 Gönner, 207  
 Gooch, 188, 211, 212  
 Goodell, 229, 253, 282, 287, 288, 290  
 Gosset, 17  
 Gottschalk, 192, 202, 207, 735, 736, 738, 837  
 Gould, 30  
 Goupil, 23, 525, 555  
 Guérin, 534  
 Gulland, 57  
 Gurlt, 561  
 Gusserow, 21, 557, 563, 589, 606, 650, 656, 658, 679, 683, 697, 713, 715, 717, 728  
 Guyon, 570, 938, 949, 955  
 Grandin, 88  
 Gravel, 78  
 Greenhalgh, 292, 603  
 Griffin, 274, 275  
 Griffith, 478, 679, 851, 852, 865  
  
 HAGEDORN, 688, 748, 761, 885, 893  
 Hall, 586  
 Hamilton, 143  
 Hardie, 573  
 Harding, 341  
 Harle, 340  
 Harris, 340  
 Hart, 4, 23, 465, 466, 467, 534, 544, 756, 771, 806  
 Hartmann, 694, 818  
  
 Haultain, 72  
 Hayes, 282  
 Head, 45, 261, 866  
 Hebra, 376, 382  
 Heer, 590  
 Hegar, 11, 13, 21, 186, 281, 282, 293, 318, 364, 602, 622, 698, 752, 753, 758, 760, 762, 769, 770, 771, 773, 866  
 Heil, 84  
 Heinrichius, 204, 206, 299  
 Hellin, 66  
 Helme, 443  
 Henke, 58  
 Hennig, 805  
 Henriët, 949  
 Heoff, von, 816, 817  
 Heppaer, 101, 102  
 Herber, 525  
 Herman, 33, 478, 679  
 Hernandez, 713  
 Hertz, 566  
 Herzfeld, 698, 699  
 Hewitt, 6, 286, 544, 585  
 Hicks, 26, 470, 471  
 Higginson, 640, 904  
 Hildebrandt, 597  
 Hippocrates, 585  
 Hirschfeld, 382, 575  
 His, 45  
 Hoehenegg, 698  
 Hodge, 6, 419, 420, 521, 599, 870  
 Hofmeier, 200, 201, 622, 701, 714, 720, 721, 731  
 Hollander, 74, 75  
 Homans, 68  
 Huguier, 5, 528, 538, 557  
 Hunter, 8, 873  
 Hüter, 72, 378  
  
 ILLICH, 798  
 Imlach, 537  
 Immerwahr, 207  
 Israel, 798  
  
 JACKSON, 359  
 Jacobs, 519, 621, 628  
 Jacquemier, 577  
 Jagoe, 341  
 Jani, 794  
 Janvrin, 825, 826  
 Jeaffreson, 873  
 Jessett, 295, 596, 874  
 Jessop, 469  
 Jobert, 779  
 Jonas, 587  
 Jones, 347  
 Jones, Dixon (C.), 825, 826  
 Jones, Dixon (M.), 805, 843  
 Jones, M'Naughton, 282  
 Jones, Sydney, 880, 881, 884, 889  
 Junker, 273  
 Jusserand, Nové, 736, 737, 740

- KAHLDEN, VON, 724  
 Kaltenbach, 293, 622, 694, 712, 773, 804,  
 813, 814, 816, 817  
 Kammerer, 359  
 Keating, 800  
 Kehrler, 359  
 Keiller, 487  
 Keith, 10, 12, 14, 16, 342, 598, 616, 620,  
 622, 626, 643, 873, 884, 885, 886, 889,  
 892, 908  
 Keith, Skene, 480  
 Kelly, 55, 432, 625, 894  
 Kemarski, 917  
 Kennedy, 384  
 Keppler, 69  
 Key, 642  
 Kilian, 443  
 King, 873  
 Kiorisch, 5  
 Kiwisch, 920  
 Klebs, 73, 100, 101, 444, 564, 650, 843, 846  
 Klein, 739  
 Klob, 210, 445, 562, 592, 843, 846, 913  
 Klotz, 193  
 Kobelt, 70, 72  
 Koch, 30  
 Koeberlé, 8, 10, 614, 620, 622, 628, 638,  
 642  
 Kolaczek, 841  
 Kölliker, 443  
 König, 4  
 Kossmann, 69, 799, 805  
 Kraske, 698  
 Kroner, 919  
 Krug, 627  
 Krukenberg, 693, 713, 720, 946, 947  
 Küchenmeister, 291, 292, 365  
 Kundrat, 27  
 Kussmaul, 73  
 Küstner, 191, 200, 204, 649, 921
- LACHAPELLE, 435  
 Lacroix, 736, 737, 740  
 Lallemand, 17  
 Lamballe, 17  
 Landau, 519, 652, 692, 694, 728, 732, 780,  
 813, 817, 825, 826  
 Landerer, 732, 733, 841, 842  
 Lane, 877  
 Langenbeck, 700  
 Langhans, 736  
 Langier, 525, 936  
 Lantos, 209  
 Lebert, 21  
 Lee, 5, 189, 586, 592  
 Lefort, 73, 89, 757, 759, 760  
 Lefour, 593, 595  
 Leiter, 257, 258  
 Lambert, 899, 900  
 Leopold, 27, 48, 472, 519, 589, 592, 596,  
 634, 653, 818, 843  
 Lepage, 434
- Lewers, 281, 488  
 Lever, 22  
 Lindsay, 105  
 Lisfranc, 5, 586, 918  
 Lister, 2, 10, 30, 622, 631, 873, 884  
 Lockwood, 252  
 Locock, 293  
 Löhlein, 739  
 Lucas, 342  
 Luschka, 443  
 Lusk, 346, 593  
 Luther, 374
- M'CLINTOCK, 525, 526, 547, 550, 563  
 M'Dowell, 7, 8, 873  
 Mackenrodt, 478, 692, 764, 765  
 Madge, 525, 544, 547  
 Mainert, 624  
 Maisonneuve, 293  
 Makins, 487  
 Malassez, 846  
 Malcolm, 252  
 Malgaigne, 525  
 Malherbe, 474  
 Mallet, 583  
 Mangiagalli, 79, 694, 695, 696, 720  
 Marchand, 71, 736, 737, 843, 846  
 Marckwald, 769, 770  
 Marconnat, 389  
 Marey, 564  
 Martin, 12, 20, 57, 75, 76, 78, 79, 192, 292,  
 384, 413, 438, 439, 472, 519, 621, 752,  
 753, 760, 761, 762, 768, 771, 794, 795,  
 806, 812, 821, 841, 909  
 Martin, C., 106  
 May, 342  
 Mayor, 443  
 Meadows, 292, 525, 533, 556, 559  
 Meredith, 858  
 Merge, 207, 738, 794  
 Meyer, 102  
 Michaëlis, 639  
 Minot, 118, 126  
 Mitchell, Weir, 213, 228, 229  
 Molitor, 342  
 Mollinetti, 929  
 Moostakov, 105  
 Morand, 873  
 More Madden, 276, 290  
 Morgagni, 49, 64, 72, 87  
 Mott, 445  
 Müller, 84, 342, 390, 593, 630, 656, 657,  
 658, 681  
 Mundé, 209, 293  
 Munster, 795  
 Muret, 461  
 Murray, Milne, 365, 598, 600  
 Museux, 919, 920
- NAGEL, 60, 837  
 NÉLATON, 293, 525, 526, 556, 557, 600, 880,  
 881

- Netter, 798  
 Neudorfer, 931  
 Neugebauer, 263, 274, 437, 438, 779, 781  
 Newnham, 916  
 Nikiforoff, 819  
 Noble, 460  
 Nöggerath, 373, 919  
 Nonat, 293, 528  
 Nordau, Max, 223  
 Nunn, 942  
  
 OLSANDER, 936  
 Olshausen, 67, 203, 204, 207, 252, 293,  
 525, 539, 606, 690, 712, 838, 840, 842,  
 844, 845, 846, 864, 866  
 Orthmann, 384, 794, 795, 812  
 Ott, de, 604  
  
 PAGET, 12, 21, 585, 934  
 Palmer, 197, 210, 288, 289  
 Paquelin, 266, 291, 609, 627, 705, 706,  
 731, 762  
 Paré, 17  
 Paroua, 802  
 Parry, 463, 464, 478, 479  
 Pasteur, 30  
 Paul, 22  
 Péan, 106, 517, 518, 604, 621, 622, 692, 820  
 Pearson, 290  
 Peaslee, 282, 292  
 Penrose, 84, 794  
 Petit, 929  
 Pfannenstiel, 207, 714, 725, 726  
 Pflüger, 66, 370  
 Phillips, 105, 281, 282, 536  
 Pick, 725, 726  
 Picot, 656, 659  
 Playfair, 206, 263, 264, 285, 356, 541,  
 551, 631  
 Pogg, 525  
 Poirier, 42, 43  
 Pole, 79  
 Polk, 3, 488, 625, 627, 634  
 Poncet, 542, 545, 552  
 Popoff, 72  
 Porak, 270, 577  
 Porritt, 377  
 Porro, 595, 596, 634, 637, 712  
 Porter, 825  
 Pott, 932  
 Pozzi, 34, 84, 97, 99, 101, 104, 191, 194,  
 212, 292, 341, 345, 526, 534, 546, 557,  
 559, 577, 593, 746, 779, 908, 909  
 Preuschen, v., 390  
 Priestley, 1, 210, 288, 289, 292, 370, 374,  
 552  
 Prochownik, 201, 218, 341, 420, 800  
 Prost, 528  
 Puech, 67, 90, 525, 534  
  
 QUILSING, 84  
  
 RAINEY, 240  
  
 Rauschnig, 92  
 Reamier, 700  
 Recamier, 5, 21, 292, 293, 294, 524  
 Recklinghausen, v., 806, 814, 816, 824  
 Reeve, 914  
 Regnier, 559  
 Reid, 289, 290  
 Rémy, 84  
 Renaud, 812  
 Retzius, 51, 943  
 Reverdin, 290  
 Reymond, 309, 801  
 Reynolds, 210, 552  
 Rhein, 589  
 Rheinstein, 813, 817  
 Richard, 69  
 Richelot, 519, 604, 621, 628, 633, 692, 694,  
 695  
 Rieux, 588  
 Rindfleisch, 607, 846  
 Ritchie, 802  
 Rivington, 946  
 Robert, 528, 548  
 Robertson, 342  
 Robin, 443  
 Rokitansky, 21, 101, 210, 700, 803, 837,  
 843, 846, 913  
 Roser, 189  
 Rouget, 525, 527  
 Routh, 204, 295, 590, 591, 597, 747, 813, 816  
 Routh, C. H. F., 281, 286, 293  
 Routier, 559, 821, 822  
 Roux, 17  
 Rowlett, 342  
 Ruedinger, 37  
 Ruge, 20, 79, 189, 196, 197, 198, 203, 204,  
 205, 650, 651, 652, 679, 680, 731, 732  
 Ruppolt, 69  
 Ruysch, 525  
  
 SAINT-HILAIRE, 73  
 Sajous, 913  
 Sale, 476  
 Sängler, 73, 373, 374, 443, 595, 634, 636,  
 692, 712, 734, 735, 736, 801, 802, 805,  
 806, 812, 813, 814, 816, 817, 818, 820,  
 824, 825, 826  
 Savage, 292, 599  
 Scanzoni, 214, 293, 379, 525, 534, 538,  
 563, 812, 924  
 Schäffer, 84, 375, 488  
 Schatz, 432  
 Schauta, 699  
 Schleich, 272  
 Schlesinger, 4  
 Schmidt, 342, 731  
 Schneevocht, 384  
 Schramm, 786, 795  
 Schroeder, 12, 13, 76, 201, 202, 210, 292,  
 293, 382, 534, 535, 538, 544, 563, 582,  
 584, 595, 606, 622, 628, 651, 656, 701,  
 713, 720, 724, 771, 807, 812

- Schuchardt, 391  
 Schultz, 707  
 Schültze, 199, 279, 420, 522, 841, 917, 918  
 Schwartz, 800  
 Segond, 517, 519  
 Semon, 605, 607  
 Senger, 814, 824, 825, 826  
 Sequeira, 440  
 Seyfert, 525  
 Shattock, 818, 819, 844  
 Sheild, 265  
 Shucking, 763  
 Siebold, v., 29  
 Silcock, 793, 794  
 Simon, 17, 293, 752, 753, 770, 773, 777,  
 778, 779, 781  
 Simpson, A. R., 597, 769, 771, 850, 915  
 Simpson, Sir J. Y., 5, 193, 200, 201, 211,  
 216, 274, 276, 290, 292, 330, 348, 362,  
 365, 384, 447, 449, 450, 525, 528, 530,  
 544, 550, 552, 558, 559, 594, 600, 656,  
 800, 920  
 Sims, Marion, 17, 55, 56, 262, 264, 274,  
 277, 283, 288, 292, 293, 362, 364, 387,  
 390, 599, 748, 753, 755, 757, 758, 761,  
 763, 764, 765, 766, 767, 768, 769, 771,  
 773, 774, 776, 777, 778, 779, 919, 920  
 Sinclair, 12, 696  
 Sinéty, de, 82, 204, 205, 214, 215, 437, 846  
 Sippel, 68, 909  
 Skene, 62, 68, 74, 75, 432, 577, 928  
 Skoldberg, 201  
 Sloan, 276  
 Smart, 340  
 Smith, 342  
 Smith, Albert, 420  
 Smith, Greig, 628, 633, 634, 712  
 Smith, Heywood, 282, 342  
 Smith, Tyler, 5, 8, 28, 29, 188, 189, 920,  
 922  
 Smyly, 820  
 Sonnenburg, 931  
 Sorel, 370  
 Spaeth, 800  
 Spamer, 310  
 Spiegelberg, 199, 589, 594, 682, 725, 844,  
 925  
 Stefflich, 844  
 Stephenson, 3  
 Stevenson, 480  
 Stewart, Sir Grainger, 71, 798  
 Stoltz, 550, 756, 761, 762  
 Storer, 639  
 Stratz, 585  
 Strauch, v., 559  
 Strong, 95  
 Suppinger, 85  
 Susserot, 563, 593  
 Sutton, Bland, 15, 16, 50, 62, 67, 70, 471,  
 532, 562, 784, 793, 800, 804, 805, 806,  
 810, 811, 839, 840, 841, 844, 846, 871  
 Svensson, 913
- TAIT, LAWSON, 11, 12, 14, 16, 68, 105,  
 192, 252, 290, 328, 464, 471, 478, 479,  
 527, 531, 557, 591, 601, 873, 877, 878,  
 883, 889, 893  
 Tardieu, 105, 535  
 Tarnowski, 374  
 Tate, 920  
 Taylor, 462, 469, 522, 914  
 Teale, 284  
 Terrier, 694  
 Theilhaber, 711, 712, 713  
 Thiersch, 19, 653, 735  
 Thiry, 922  
 Thomas, Gaillard, 23, 197, 201, 293, 295,  
 420, 557, 917, 920, 921, 922  
 Thompson, Sir Henry, 942  
 Thomson, 113, 269  
 Thornton, Knowsley, 9, 11, 480, 532,  
 622, 638, 678, 817, 841, 848, 880  
 Tilt, 6, 525  
 Tinns, 576  
 Tourneaux, 96  
 Trelat, 286  
 Trendelenburg, 515, 874, 904, 906, 908,  
 931  
 Treub, 802  
 Treves, 252, 498  
 Trouseau, 293, 533, 536  
 Tuckwell, 525, 538  
 Tuffier, 818, 932, 934, 943, 947  
 Turner, 585  
 Tyson, 942
- UNDERHILL, 605, 606
- VEIT, 20, 21, 189, 196, 197, 203, 204, 374,  
 387, 535, 650, 651, 652, 679, 680, 731,  
 732, 817  
 Velitz, v., 840  
 Velpeau, 6, 17, 417, 604  
 Verneuil, 528, 809  
 Viatto, 382  
 Vidal, 780  
 Vignes, 525, 531  
 Virchow, 19, 21, 39, 366, 485, 525, 535,  
 576, 591, 650, 724, 725, 826, 846  
 Voelcker, 821, 822  
 Voison, 525, 526, 527, 529, 531, 532, 533,  
 534, 536, 537, 539, 540, 542, 545, 546,  
 547, 549, 556  
 Volkneaux, 294  
 Vulliet, 274, 276, 707
- WAGNER, 607, 656  
 Waldeyer, 19, 49, 52, 60, 650, 653, 839,  
 846  
 Wallent, 341  
 Walsham, 947  
 Walter, 477, 805, 810  
 Warnck, 810, 819  
 Wathen, 290  
 Wateville, de, 33



- Watts, 920  
Webb, 765  
Weber, 256  
Weber, F., 552, 592  
Webster, Clarence, 464  
Weichselbaum, 786  
Weigert, 725  
Wells, Sir Spencer, 8, 9, 10, 91, 532, 616,  
637, 642, 656, 748, 749, 751, 758, 761,  
774, 799, 806, 807, 817, 873, 877, 878,  
879, 880, 881, 883, 884, 889  
Wertheim, 863, 865, 866  
West, 5, 189, 525, 536, 542, 544, 558, 563,  
936  
Westermark, 820  
Weston, 305  
White, 29, 922  
Williams, Sir John, 2, 7, 19, 20, 26, 27,  
361, 364, 444, 480, 552, 648, 652, 670,  
674, 678, 701, 702, 730, 731, 812  
Williams, J. D., 66, 69, 70, 71, 72  
Williams, Whitridge, 724, 788, 794, 795,  
799, 805, 839, 846, 865, 866  
Willius, 873  
Wilmont, 946  
Wilson, 342, 476  
Wiltshire, 28  
Winckel, 65, 66, 71, 206, 388, 534, 562,  
563, 593, 658, 660, 679, 683, 684, 699,  
729, 869  
Winter, 189, 207, 696, 697, 701, 702  
Winternitz, 780  
Woodhead, Sims, 353  
Worrall, 477  
Wright, 256, 356  
Wyder, 27, 29, 203, 204, 205, 570  
Wylie, 366  
Wynter, 820, 821, 822  
  
ZEDEL, 821  
Zemann, 798  
Ziegler, 731  
Zinnis, 67  
Zuccarelli, 103  
Zuckerandl, 698  
Zwanck, 408  
Zweifel, 559, 621, 627, 694, 804, 817,  
820



## INDEX

- ABDOMEN**, examination of, 171  
Abdominal tumour, recognition of, 854  
Abnormalities causing disease of the genital organs in women, 112  
Accidental and operative causes of diseases of the genital organs in women, 147  
Actinomycosis of the Fallopian tube, 798  
Acute inflammation of ovarian tumours, 849  
Adenoma malignum, 729  
Adenoma (simple) of uterus, 605  
Alexander-Adams operation, 411  
Amenorrhœa, 27, 343; primary and permanent, 343; secondary, 344; symptoms of, 347; treatment of, 347  
Anæsthesia in gynæcology, 272  
Anatomy of the female pelvic organs, 31  
Anatomy of female pelvic organs, recent developments in, 2  
Anteflexions of the uterus, see Antrorsions of the uterus.  
Anteversions of the uterus, see Antrorsions of the uterus  
Antiseptics in gynæcology, 267  
Antrorsions of the uterus, 420; causes and complications of, 421; diagnosis of, 422; symptoms of, 421; treatment of, 423  
Apthous vulvitis, 377  
Appendages, uterine removal of, 904  
Armamentarium, electrical, 300  
Ascent of the uterus, 394  
Atrophy and hypertrophy of the Fallopian tubes, 783
- BALNEO-THERAPEUTICS** in gynæcology, 255  
Bladder, anatomy of, 37; diseases of, 928; cystitis (acute), 936, (chronic), 940; displacement of, 928; ectopic vesicæ, 930; functional diseases of, 932; foreign bodies in, 949; rupture of, 946; stone in, 956; tubercular disease of, 942; tumours of, 951; vesico-vaginal fistula, 948  
Bloodletting in gynæcology, 265  
Broad ligament, cysts of, 845  
Broad ligaments, malformations of, 73
- CÆSAREAN** section, 634  
Calculus vesicæ, see Stone in the bladder, 956  
Cancer of cervix, 670  
Cancer of genital organs, etiology of, 133, 643  
Cancer of the Fallopian tubes, 812; several considerations of, 823; treatment of, 823  
Cancer of body of uterus, 713; diagnosis of, 718; etiology of, 715; pathological anatomy of, 713; prognosis of, 720; symptoms of, 715; treatment of, 721  
Cancer of the ovary, 844  
Cancer of vagina, 391  
Carcinoma uteri, 181, 643  
Catarrh of cervix, see Cervical catarrh  
Cavernous angioma of uterus, 591  
Cervical catarrh, 195; clinical history and symptoms of, 195; diagnosis of, 198; pathology in relation to physical signs, 196; treatment of, 199  
Cervical deformities, operation for, 769  
Cervicitis, etiology, 117  
Cervico-vaginal fistula, 441  
Cervix, circular amputation of (Hegar), 769; fibromyoma of, 582; infravaginal hypertrophy of, 763; Marckwald's operation, 770; Sims' conoidal incision, 769; lacerations of, 426; operation for laceration of, 765; supravaginal amputation of, 701; supravaginal hypertrophy of, 763  
Child-bearing, influence of fibromyoma on, 592  
Chronic pelvic cellulitis, 497  
Cirrhosis of the ovary, 864  
Clitoris and labia, malformations of, 96  
Colpitis, 385  
Colpitis mycotica, 388  
Colpoperineorrhaphy, A. Martin's method, 761

- Colporrhaphy, 410, 757  
 Colpotomy, 420, 522  
 Complete abdominal hysterectomy, 626  
 Complications of ovarian tumour, 848  
 Condyloma of vulva, 381  
 Congenital defects of development as a cause of disease of the female genital organs, 112  
 Connective tissue of pelvis, anatomy of, 38  
 Conservative operations on the ovaries and tubes, 909  
 Contagious diseases as causes of disease of the genital organs in women, 142  
 Continuous current, mode of action, 315  
 Curetting of uterus, 292, 355  
 Current regulator in electrical treatment, 303  
 Cystic corpora lutea, 837  
 Cystitis, acute, 936; chronic, 940  
 Cystocele (Stoltz operation), 761  
 Cystoma, proliferating, 838  
 Cysts of the broad ligaments, 845  
 Cysts of the Fallopian tube, 801
- DECIDUOMA malignum, 734; course and symptoms of, 737; diagnosis of, 740; pathological anatomy of, 736; prognosis of, 741; treatment of, 741  
 Deciduoma malignum of the Fallopian tubes, 826  
 Delépine's, Professor, description of methods of microscopical examination of uterine tissues, 681  
 Dermoid growths, ovariectomy for, 894  
 Dermoid structures in ovarian cysts, 840  
 Dermoid tumours of the Fallopian tube, 802  
 Dermoid tumour of ovary, etiology of, 126  
 Descent of the uterus, 395; causes of, 397; complications of, 401; degrees of, 395; pathological anatomy of, 396; physical diagnosis of, 402; prognosis of, 404; symptoms of, 402; treatment of, 404  
 Diagnosis of chronic inversion of the uterus, 915  
 Diagnosis in gynæcology, 151; additional means of examination, 186; examination of the abdomen, 171; examination by the vagina, 177; history of the patient, 151; history of present illness, 160; menstrual history, 153; obstetric history, 158; examination by means of sound, 185; previous illnesses, 160  
 Diet, etiology of disease resulting from improper, 140  
 Diffuse pelvic suppuration, 492  
 Dilatation of the uterus in gynæcology, 276  
 Dilatation, rapid, of uterus, 281
- Diphtheritic vaginitis, 389  
 Displacement of bladder, 928  
 Displacements of the uterus, 393  
 Dysmenorrhœa, 28, 358; etiology of, 117; from defective development and obstruction, 361; intermenstrual, 369; membranous, 28, 366; spasmodic and inflammatory, 362; and sterility, 359; symptoms of, 363; treatment of, 364; varieties of, 360
- Ectopion vesicæ, 930  
 Eczematous vulvitis, 576  
 Education of girls at and about the period of puberty, 220  
 Education of girls, etiology of disease resulting from, 134  
 Electrical treatment in diseases of women, 13, 300  
 Electrical treatment of fibromyoma, 14, 324, 597  
 Electricity, mode of application in gynæcology, 318; therapeutic application of, 317; armamentarium in, 300  
 Elephantiasis vulvæ, 382  
 Elytritis, 385  
 Elytropheorrhaphy, *vide* Colpoperineorrhaphy, 760  
 Elytrophasty, 779  
 Elytrophaphy, 420  
 Elytropheorrhaphy, *vide* Colporrhaphy, 757  
 Emphysematous vaginitis, 388  
 Endometritis, chronic, 203; clinical history and symptoms of, 203; diagnosis of, 203; etiology of, 122; pathology of, in relation to physical signs, 204; relation of micro-organisms to, 206; treatment of, 209; treatment of, by electricity, 320  
 Endometritis-villous, 352  
 Episio-perineorrhaphy, 757  
 Epispadias in woman, 95  
 Epithelioma portionis vaginalis uteri, 646; causes of death from, 668; diagnosis of, 673; duration of the disease, 669; etiology of, 133, 655; palliative operations for, 703; pathological anatomy of epithelioma of uterus, 646; pregnancy a complication of, 710; prognosis of, 685; recurrence after operation, 696; seat of origin of growth, 651; symptoms and clinical course of, 661; treatment of, 686  
 Erysipelas vulvæ, 378  
 Etiology of the diseases of the female genital organs, 112  
 Exfoliative vaginitis, 389  
 Extirpation of uterus, operation for, 686; Freund's operation for, 700; operations for partial, 701; recurrence after operation for, 696; results of, 693; sacral method of, 698



- Extraperitoneal hæmatocele, 530  
 Extra-uterine dysmenorrhœa, 367  
 Extra-uterine gestation, 451, see Tubal pregnancy
- FALLOPIAN tubes, anatomy of, 48; actinomyces of, 798; atrophy and hypertrophy of, 783; calculus simulating tumour of, 799; cancer of, 812; cysts of, 801; deciduoma malignum of, 826; dermoid tumours of, 802; diseases of the, 782; fibroma and enchondroma of, 798; hydatid disease of, 797; inflammation of, 784; injuries of, 782; lipoma of, 802; malformations of, 69; myoma of, 799; papilloma of, 803; sarcoma of, 824; tuberculosis of, 793
- Female pelvic organs, anatomy of, 31  
 Fibrous-polypus, 609  
 Fibro-adenoma of uterus, 606  
 Fibro-cystic tumours, 586  
 Fibroid tumour of uterus, see Fibromyoma  
 Fibroid of vagina, 390; vulva, 384  
 Fibroma and enchondroma of the Fallopian tube, 798  
 Fibromyoma of uterus, 561, 612; absorption and atrophy of, 587, 595; calcification of, 585; cervix in, 582; cystic changes in, 586; diagnosis of, 574; diagnosis of subperitoneal, 578; electrical treatment of, 324, 597; growth and course of, 576; hæmorrhages from, 572; hæmorrhage, source of, 572; influence of, in child-bearing, 592; influence of pregnancy on, 592; influence of sterility, 564; interstitial, 580; malignant degeneration of, 586; medical treatment of, 596; pain connected with, 575; pathological anatomy of, 564; pregnancy connected with, 592; pregnancy, treatment of, connected with, 595; secondary changes in, 585; sloughing of, 586; submucous variety of, 576; subperitoneal, 575; symptoms of subperitoneal, 577; surgical treatment of, 599; symptoms of, 573
- Fibrous-papilloma of uterus, 607  
 Fistulæ, vaginal, 436  
 Fistulous openings, operation for repair of, 771  
 Flap-splitting or *dédoublement*, 775; fæcal fistulæ, 782  
 Forceps delivery as a cause of laceration, 426  
 Foreign bodies in the bladder, 949; symptoms of, 950; treatment of, 950  
 Foreign bodies in vagina, 391  
 Freund's operation for total extirpation of uterus, 700
- Functional disease of the bladder, 932  
 Functional disease of distant organs (secondary) in gynæcology, 225
- GALVANOMETER in electrical treatment, 304  
 Genital organs of women, development of, 27, 64; etiology of diseases of, 112; hyperæmia of, 372; inflammation of, 373; malformations of, 63  
 Genital organs, external, diseases of, 372  
 Gonorrhœa, etiology of disease resulting from, 143  
 Grape-like sarcoma of uterus, 725  
 Gravid uterus, operations on, 633  
 Gynæcological therapeutics, 249; balneo-therapeutics in, 255; bloodletting in, 265; drugs in, 252; general hygiene in, 250; local therapeutical measures in, 256; operations in gynæcology, 267; rest in, 251; antiseptics in, 267  
 Gynæcology, development of modern, 1; anatomy, 2; disorders of menstruation, 27; extra-uterine pregnancy, 14; inversio uteri, 29; malignant diseases, 19; pathological and clinical aspects, 5; pelvic inflammations, 22; surgery in, 7; vesico-vaginal fistulæ, 17
- HÆMATOCELE, pelvic, 524; causes of, 538; definition and synonym of, 524; diagnosis of, 547; extraperitoneal, 530; intraperitoneal, 529; pathological anatomy of, 536; pathology of, 525; prognosis of, 551; sources of hæmorrhage, 581; symptoms and progress of, 540; treatment of, 553  
 Hæmatoma, see Hæmatocele  
 Hæmatoma of the ovary, 868  
 Hæmatoma vulvæ, 381  
 Hæmorrhage, from fibro-myomata, 572  
 Heredity as a cause of disease of the female genital organs, 112  
 Hermaphroditism, 100  
 Hernia of ovary, 871; symptoms of, 871; diagnosis of, 872  
 Hernia of vulva, 379  
 Herpes vulvæ, 376  
 Hydatids of the ovary, 841  
 Hydatids, etiology of disease resulting from, 147  
 Hydrops folliculorum, 837  
 Hymen, the, 178; anatomy of, 34; cause of imperforate, 116; malformations of, 97  
 Hypospadias in woman, 95  
 Hysterectomy, 611; after treatment, 639; complete abdominal hysterectomy, 626; for fibromyoma, 12, 604; for intractable inversion, 633; for proci-dentia, 630; supravaginal extraperi-

- toneal, 614; intraperitoneal, 618; Baer's operation, 622; Byford's operation, 624; Dudley and Goffe's operation, 623; Eastman and Chrobak's operation, 624; Polk's operation, 625
- Hystero-epilepsy, oophorectomy in, 230
- Hysteroma, see Fibromyoma
- Hysteropexy, 411, 763
- IDIOPATHIC** hæmorrhage, 353
- Incarceration of ovarian tumours in the pelvis, 851
- Incontinence of urine, 934
- Inflammation of the Fallopian tubes, 784
- Inflammation of the ovaries, 861
- Inflammation of the uterus, 187
- Injuries to bladder, 946
- Injuries of the Fallopian tubes, 782
- Insanity in relation to gynæcology, 229
- Intermenstrual dysmenorrhœa, 369
- Interstitial fibromyoma, 580
- Intraligamentous tumours, ovariectomy for, 895
- Intraperitoneal hæmatocele, 529
- Inversio uteri, 29
- Inversion, chronic, of the uterus, 911; anatomy and pathology of, 912; course and results of, 917; diagnosis of, 915; etiology of, 914; mechanism of production, 913; symptoms of, 915; treatment of, 918
- Inversion of uterus, hysterectomy for, 633
- Involution of uterus, 442
- KOLPO-HYSTERECTOMY**, 631
- Kolpokleisis, 779
- Kraurosis vulvæ, 584
- LABIA** majora, anatomy of, 34
- Labia minor, anatomy of, 34
- Laceration of cervix, etiology of, 119; immediate repair of, 426; results of, 427
- Lacerations of pelvic floor proper, 746
- Laparotomy in pelvic peritonitis, 514
- Lateral deviations of the uterus, 423
- Lefort's operation, 759
- Leioma, 562
- Lipoma of the Fallopian tube, 802
- Local therapeutical measures in gynæcology, 256
- Lupus vulvæ, 22, 382
- Lymphatics of pelvis, anatomy of, 44
- MALIGNANT** disease of uterus, 643
- Malignant diseases of vulva, 383
- Malignant growths in ovarian cysts, 841
- Marriage, etiology of disease following, 141
- Mechanism of production of chronic inversion of the uterus, 913
- Membranous dysmenorrhœa, 28, 366
- Menorrhagia and metrorrhagia, 349; during active, fertile life, 351; during menopause, 354; during puberty, 351; symptoms of, 354; treatment of, 354; idiopathic, 353
- Menstruation, disorders of, 26, 339; etiology of disorders, 135; its relation to the education of girls, 221; premature, 339; protracted, 343; scanty, 348; vicarious, 347
- Mesometric gestation, 463
- Metritis and endometritis, acute, 202; chronic, 203; clinical history and symptoms of, 202; diagnosis of, 207; pathology of, in relation to physical signs, 204; treatment of, 209
- Micro-organisms in the etiology of disease of the female genital organs, 206
- Myoma of the Fallopian tube, 799
- Myoma of uterus, etiology of, 131
- NATURAL** progress of ovarian tumours, 847
- Nerves of pelvis, anatomy of, 44
- Nervous system in relation to gynæcology, 220
- Neurasthenia in relation to gynæcology, 227
- Neuroses, oophorectomy and, 230
- Noma pudendi, 377
- Nutrition, defective, in gynæcology, 227
- OOPHORECTOMY**, 11, 904; in functional neuroses, 230; in inflamed and adherent appendages, 906; for fibromyoma, 906
- Oophoritis, 862; diagnosis of, 868; symptoms of, 866; treatment of, 868
- Oophoritis serosa, 864; tubercular, 865
- Operations in gynæcology, 267
- Operative causes of disease of female genital organs, 147
- Ovarian artery, anatomy of, 49
- Ovarian cystoma, etiology of, 127
- Ovarian pregnancy, 471
- Ovarian tumours, 836; acute inflammation of, 849; complications of, 848; diagnosis of, 852; etiology of, 845; incarceration of, in the pelvis, 851; natural progress of, 847; pregnancy and labour complicated by, 851; rupture of, 851; strangulation of the pedicle in, 860; torsion of the pedicle in, 849
- Ovaries, anatomy of, 49; carcinoma of, 844; cirrhosis of, 864; hæmatoma of, 868; hernia of, 871; hydatids of, 841; malformation of, 65; œdema of, 864; prolapse of, 869; removal of, and menstruation, 346; sarcoma of, 843; tubercle of, 865; tumour of, 836

- Ovaries and tubes, removal of, for fibromyoma, 628
- Ovariectomy, 7, 872; accidents and complications in, 897; adhesions in, 888; after treatment in, 900; arrangements for operation, 876; coverings of the patient in, 875; drainage in, 892; dressings in, 893; emptying and delivering cyst in, 887; history of, 873; incomplete operations, 897; instruments used in, 877; irrigation in, 891; operating table in, 874; operating room in, 874; parietal incision in, 886; pedicle, treatment of, in, 889; peritoneum, toilet of, in, 891; pregnancy, ovariectomy in, 896; preparation of patient for, 875; preparatory measures in, 873; sponges and sponge-cloths in, 876; suturing the parietal wound in, 893
- Ovary, solid tumours of, ovariectomy for, 895
- PALLIATIVE operations for cancer of the uterus, 703
- Papilloma of the Fallopian tube, 803
- Papilloma of genital organs, etiology of, 130
- Parametritis, see Pelvic cellulitis
- Parovarian cyst, etiology of, 127
- Parturition, morbid conditions resulting from, 425
- Pelvic abscess, 491
- Pelvic cellulitis, 487; anatomy of, 487; diagnosis of, 493; definition of, 487; etiology of, 88; frequency of, 489; pathological anatomy of, 489; physical signs of, 490; prognosis of, 495; treatment of, 496; symptoms of, 489
- Pelvic exudations, treatment of, by electricity, 335
- Pelvic floor, anatomy of, 744; injuries of, 431
- Pelvic inflammation, 22, 485
- Pelvic organs, anatomy of, 31; development of, 57
- Pelvic peritonitis, 498; definition and nature, 498; diagnosis of, 509; etiology of, 498; pathological anatomy of, 503; physical signs of, 509; prognosis of, 511; symptoms of, 506; treatment of, 513
- Pelvis, dissectional anatomy of, 53; structural anatomy of, 55; surgical anatomy of, 56
- Perimetritis, see Pelvic peritonitis
- Perineorrhaphy, Alexander Duke's method, 754; A. Martin's method, 753; Simon-Ilegar operation, 752
- Perineum, anatomy of, 54; rupture of the, 433; complete rupture of, 745; partial rupture of, 745; plastic operation for complete rupture of (perineorrhaphy), 747
- Perioophoritis, 498, 861
- Perisalpingitis, 498
- Peritoneum, anatomy of pelvic, 3, 50
- Peritonitis, etiology of, 144
- Peri-uterine phlegmon, see Pelvic cellulitis
- Personal habits as causes of disease of the genital organs in woman, 135
- Phlegmonous perivaginitis, 389
- Physical exercise in relation to the education of girls, 321
- Placental polypus, 609
- Plastic gynaecological operations, 743
- Plastic operations for displacements of pelvic floor, 756; for pelvic floor lacerations, Emmet, 754
- Polypus uteri, 557; fibrous, 609; formation of, 570; hæmorrhage, source of, 573; intermittent, 571; inversion of uterus from, 571, 915; leucorrhœa connected with, 573; placental, 609; removal of, 603; sloughing of, 571, 586
- Porro's operation, 637
- Pregnancy as a complication of cancer of the uterus, 710; diagnosis of, 173; influence of, on fibromyoma, 592; ovariectomy in, 896
- Premature menstruation, 339
- Primary and permanent amenorrhœa, 343
- Procidencia uteri, 395
- Procidencia, hysterectomy for, 630
- Prolapse of the ovary, 869
- Prolapse of uterus, 395
- Prolapse of urethral mucous membrane, 762
- Protracted menstruation, 343
- Pruritus vulvæ, 378
- Psammoma, 839
- Puberty, menorrhagia at time of, 351
- Purgatives in gynaecology, 252
- Pyosalpinx, 505, 789; etiology of, 122
- RECTO-VAGINAL fistula, 442
- Rectum, anatomy of, 37
- Rest cure, the, in gynaecology, 228
- Rest in gynaecology, 251
- Retroflexion, see Retrorsion
- Retrorsions of the uterus, 412; causes of, 412; complications of, 414; diagnosis of, 416; prognosis of, 417; symptoms of, 414; treatment of, 417
- Retroversion of the uterus, see Retrorsion of the uterus
- Rheostats in electrical treatment, 303
- Round ligaments, malformation of, 73
- Rupture of the bladder, 946
- Rupture of cystic tumours of the ovary, 851



- SACRAL method of total extirpation of uterus, 698  
 Salpingitis, 784  
 Salpingo-oophorectomy, 904  
 Sarcoma botryoides, 725  
 Sarcoma of genital organs, etiology of, 133  
 Sarcoma of the Fallopian tubes, 824  
 Sarcoma of the ovary, 843  
 Sarcoma of uterus, 21, 722; diagnosis of, 728; pathological anatomy of, 723; prognosis of, 728; symptoms and courses, 726; treatment of, 729  
 Sarcoma of vagina, 391  
 Secondary amenorrhœa, 344  
 Septic vulvitis, 377  
 Serous perimetritis, 503  
 Sexual appetite, causes of defective, in women, 135  
 Sexual organs, excessive use of, as a cause of disease of the genital organs in women, 142  
 Stenosis, treatment of, by electricity, 317  
 Sterility and dysmenorrhœa, 359  
 Sterility, 231; acquired sterility, 235; contingent sterility, 235; acquired contingent sterility, 238; cases of absolute sterility, 233; conditions leading to, 232; influence of fibromyoma on, 563; statistics of, 232  
 Stone in the bladder, 956; symptoms, prognosis, treatment, 957  
 Strangulation of the pedicle in ovarian tumours, 860  
 Subinvolution, treatment of, by electricity, 323  
 Submucous fibromyoma, 567  
 Subperitoneal fibromyoma, 575  
 Subperitoneo-pelvic gestation, 463  
 Superinvolution of the uterus, 447  
 Supravaginal extirpation of cervix, 701  
 Supravaginal hysterectomy, intraperitoneal, 618  
 Supravaginal hysterectomy, extraperitoneal, 614  
 Surgical anatomy of pelvis, remarks on, 56  
 Syphilis as a cause of disease of the genital organs in women, 142
- TEXTS, dilatation of uterus by, 276  
 Therapeutical operations in gynæcology, 274  
 Thrombus vulvæ, 381  
 Tight-lacing, etiology of disease from, 136  
 Tonics in gynæcology, 253  
 Torsion of the pedicle of ovarian tumours, 849  
 Trachelorrhaphy, 765  
 Tubal abortion, 458  
 Tubal moles, 455  
 Tubal pregnancy, 451; causes of, 125, 451; changes in the tube in, 454; diagnosis of, 472; differential diagnosis of, 476; the placenta and decidua in, 464; retention of the fetus in, 473; abortion in, 459; the mole in, 454; rupture in, 460; treatment of, 481  
 Tubercle of the ovary, 865  
 Tubercular disease of the bladder, 942; diagnosis of, 944; morbid anatomy of, 943; prognosis of, 945; treatment of, 945  
 Tuberculosis, etiology of disease resulting from, 146  
 Tuberculosis of the Fallopian tubes, 793; pathology of, 795; symptoms and diagnosis of, 796; treatment of, 797  
 Tubo-uterine gestation, 470  
 Tumours of the bladder, 951; pathological complications of, 953; symptom of, 953; diagnosis of, 954; prognosis of, 955; treatment of, 955  
 Tumours of the ovary, 836; complications of, 848; diagnosis of, 852; etiology of, 845; natural progress of, 847  
 Tumours of the uterus, 131, 561, 612
- URETERO-VAGINAL fistula, 437, 780  
 Ureters, anatomy of, 37  
 Urethra, anatomy of, 36; diseases of, 927  
 Urethral caruncle, 928  
 Urethrocele, 762  
 Urinary fistula, 771  
 Uterine artery, anatomy of, 41  
 Uterine appendages, removal of, in fibromyoma, 13, 601, 629  
 Uterine dysmenorrhœa, 361  
 Uterus, anatomy of, 45; adenoma of, 605; antrorsions of, 420; ascent of, 394; cancer of body of, 713; cancer of the cervix of, 670; and epithelioma portionis vaginalis of, 646; descent of, 395; fibro-adenoma of, 606; fibromyoma of, 562, see Fibromyoma; fibrous papilloma of, 607; inflammation of, 187; involution of, 443; lateral deviations of, 423; malignant diseases of, 643; malformations of, 73; morcellation of, in pelvic peritonitis, 517; mucous growths of, 605; partial extirpation of, 701; retrorsions of, 412; sarcoma of, 722; simple growths of, 561; total extirpation of, 686; ventrofixation of, 420
- VAGINA, anatomy of the, 35; diseases of, 385; examination by the, 177; injuries of, resulting from parturition, 427; malformations of, 85; tumours of, 390



- Vaginal fistula, 436  
 Vaginal fixation, 763, *vide* Hysteropexy  
 Vaginal hysterectomy in pelvic peritonitis, 517  
 Vaginal urethrocele, 762  
 Vaginismus, 389  
 Vaginitis, 385  
 Varicocele of vulva, 381  
 Vascular growth of urethra, 928  
 Veins of pelvis, anatomy of, 42  
 Venereal diseases of vulva, 379  
 Venous supply of uterus, anatomy of, 43  
 Ventro-fixation of uterus, 411, 420  
 Vesico-uterine fistula, 779  
 Vesico-utero-vaginal fistula, 779  
 Vesico-vaginal fistula, 17, 436, 772, 948 ;  
 etiology, 948 ; symptoms, 948 ; diagnosis, 948 ; treatment, 773 ; Bozeman's method, 778 ; Sims' method, 773 ; Simon's method, 777  
 Vestibule, 34  
 Vicarious menstruation, 347  
 Villous endometritis, 352  
 Vulva, diseases of, 373 ; malformations of, 93 ; pruritus of, 378 ; thrombus of, 381 ; tumours of, 383  
 Vulvitis, 373  
 "WEIR MITCHELL" treatment in gynaecology, 228

THE END













RG101

A15

Allbutt

System - 0

